

THE MANTLE AND THE SHELL OF THE VIVIPARIDAE.

By B. PRASHAD, *D.Sc., F.R.S.E.*,

Zoological Survey of India, Indian Museum, Calcutta.

(Plates XX—XXIV.)

CONTENTS.

	<i>Page.</i>
1. Introduction	253
2. Material and Methods	254
3. The Shell and the Animal	257
4. The Mantle of the Viviparidae.	
I. Previous Accounts of the Structure of the Mantle Margin	262
II. The Processes of the Mantle Margin	264
III. The Structure of the Mantle Margin of the Viviparidae.	
(a) Terminology	266
(b) Macroscopic Structure	267
(c) Histological Structure	271
5. Historical Account of the Structure of the Shell.	
I. General	276
II. Shell Sculpture	280
6. Structure of the Shell of the Viviparidae	283
7. Secretion, Composition and Formation of the Sculpture on the Shell of the Viviparidae	289
8. Review of the Literature on the Embryonic Shell-Gland and Associated Structures in Molluscs	297
9. List of References to the Literature	309
10. Reference Lettering on the Plates	318

1. INTRODUCTION.

This paper is a continuation of the work of my late lamented chief, Dr. N. Annandale, on the problem of the shell sculpture in the family Viviparidae. He published two papers (1, 2)¹ on the subject, but his sudden death in April 1924 left the work unfinished. I was hoping to take up the elucidation of the problem from where he had left it earlier, but the pressure of other official duties did not allow of the work being started sooner. The collection of material from different parts of the world is also to some extent responsible for the delay. During the period of a combined leave spent in Europe, I devoted myself to the study of this interesting problem, and the results of my work are here presented.

In view of a number of closely connected questions being included in the paper, it would be useful to indicate the scope of the paper. Beginning with a review of the different opinions regarding the relation between the animal and the shell of the Gastropod Molluscs, the enquiry is limited to the mantle, which organ alone, at least in most forms, is responsible for the secretion of the shell. In this connection the macroscopic and the histological

¹ The Arabic numerals in brackets refer to the literature cited at the end of the paper.

structure of the mantle margin of both adults and embryos of various members of the family is discussed in detail, and particular attention is devoted to special structures on the mantle margin which appear to be specifically responsible for the production of the sculpture. The question of the secretion of the various layers of the shell by specially modified regions of the mantle is discussed in detail, and a review of the literature for all families of molluscs is included. The later phases of the development of the shell-secreting area of the mantle of *Viviparus viviparus* (Linn.) have been investigated, and in view of the importance of the so-called shell-gland of the embryo and its relationship to the shell-secreting areas of the adult, a detailed survey of the literature on this structure in all classes of molluscs exclusive of the Cephalopoda, is given. An account of the minute structure of the shell of the different members of the family is included, and the question of the shell-sculpture is discussed. A separate summary of each part of the paper is given at the end of each part.

The work was mainly done in the Zoological Department of the University of Edinburgh, and I have great pleasure in acknowledging my obligation to Professor J. H. Ashworth under whose guidance the work was carried out. The constant interest, the valuable criticisms and the helpful suggestions of Professor Ashworth have been of the greatest value. I am indebted to Mr. G. C. Robson of the British Museum (Natural History), London, Dr. F. Haas of the Senckenberg Museum, Frankfurt a. Main, and Dr. L. F. de Beaufort and Dr. T. van Benthem-Jutting of the Zoological Museum, Amsterdam, for giving me facilities for examining the collections under their charge.

I have also to thank the Department of Education, Health and Lands of the Government of India for making a special grant in aid of the expenses in connection with this work.

2. MATERIAL AND METHODS.

The material of the Indian Viviparidae used in this work came mainly from the rich collections of the Zoological Survey of India, Indian Museum, Calcutta; a few of the Chinese and Japanese species are also from the same source. The rest of the material from different parts of the world was received from the British Museum (Natural History), London; Senckenberg Museum, Frankfurt a. Main; Zoological Museum, Berlin; Zoological Museum, Amsterdam; Zoological Museum, Petrograd; and the United States National Museum, Washington, U. S. A., and in this connection I am indebted to Mr. G. C. Robson, Dr. F. Haas, Dr. J. Thiele, Dr. T. van Benthem-Jutting, Mr. J. W. Lindholm and Dr. P. Bartsch for so kindly supplying me with the valuable material. Through the kind offices of Dr. Bryant Walker of Detroit, Michigan, U. S. A., I received from the University of Alabama Museum very valuable material of the peculiar American *Tulotoma magnifica* (Conrad) preserved in spirit. Dr. P. Dautzenberg of Paris was good enough to send me some interesting specimens of *Margarya*. Fresh material of the common European species, *Viviparus viviparus* (Linn.) and *V. fasciatus* (Müll.), was obtained from near Manchester through Professor Ashworth's kind help.

I give below a list of the species which I have investigated from different parts of the world. In the case of the species marked with an asterisk, gravid females containing embryos were found in the collections, and this has enabled me to include notes on the condition of the embryonic mantle in the various species.

List of Species.

Europe—

- **Viviparus viviparus* (Linn.), from near Manchester, England.
- **Viviparus fasciatus* (Müll.), from near Manchester, England.
- **Viviparus pyramidalis* (Jan.) Rossmässl., from Wörther Lake, Carinthia, Austria.
- Viviparus duboisiana* (Mousson), from Russia.

Africa—

- **Viviparus unicolor* (Olivier), from Egypt.
- **Viviparus sambesiensis* Sturany, from the Victoria Falls.
- **Neothauma tanganyicense* (Smith), from Lake Tanganyika.
- Cleopatra bulimoides* (Olivier), from near Khartoum.
- Cleopatra multilirata* Ancey, from Akotra Lake, Madagascar.
- Cleopatra trabonjiensis* Smith, from Majunga, Madagascar.

Asia—

India—

- **Viviparus bengalensis* (Lam.), from near Calcutta.
- **Viviparus dissimilis* (Müll.), from near Madras.
- **Cipangopaludina lecythis* (Benson), from Loktak Lake, Manipur.
- **Dactylochlamys oxytropis* (Benson), from Loktak Lake, Manipur.

Burma—

- **Taia shanensis* (Kobelt), from Inlé Lake, S. Shan States.
- **Taia naticoides* (Theobald) var. *intermedia* Annan., from the S. Shan States.
- **Taia intha* Annan., from Inlé Lake, S. Shan States.
- Taia elittoralis* Annan., from Inlé Lake, S. Shan States.
- **Taia crassicallosa* Annan. and Rao, from Yawnghwe.

Yunnan—

- Margarya melanoides* Nevill, from Lake Er-Hai (Lake Tali).

China—

- **Viviparus quadratus* (Benson), from Foochow.
- **Viviparus delavayana* (Heude), from Saifu, Szechuan.
- **Cipangopaludina chinensis* (Gray), from Saifu, Szechuan, and its varieties *fluminalis* (Heude) from Tsinanfu, and *diminuta* (Heude), from Pingshiung.

Japan—

- **Viviparus sclateri* (Frauenfeld), from Lake Biwa.
- Cipangopaludina malleata* (Reeve), from near Otsu.

Amur Basin, Asiatic Russia—

- **Cipangopaludina praerosa* (Gerst.), Amur River.
- Dactylochlamys ussuriensis* (Gerst.), Lake Khanka.

Sumatra—

- Viviparus sumatrensis* (Dunker), from Kael, Boentsch.

Java—

- **Viviparus javanica* (V. Busch), from Palimanan.

Celebes—

**Dactylochlamys costatus* (Quoy and Gaimard), from Minehassa.

New Guinea—

Viviparus laevigatus (Bavay), from Lake Yamoer.

Dactylochlamys tricostatus (Lesson), from Lake Sentani.

Philippine Islands—

**Dactylochlamys burroughiana* (Lea), from Luzon.

**Dactylochlamys lanaonis* (Bartsch) and vars. *iota* and *theta*, from Lake Lanao, Mindanao.

**Dactylochlamys pagodula* (Bartsch), from Lake Lanao, Mindanao.

North America—

Campeloma decisa (Say), from Potomac River, Maryland, U. S. A.

**Tulotoma magnifica* (Conrad), from Coosa River, Alabama, U. S. A.

Lioplax subcarinatus (Say), from Potomac River, Maryland, U. S. A.

The material received from various institutions consisted of specimens preserved in spirit, and was not specially preserved for histological work; in most cases, however, the preservation was found to be sufficiently good for general details. The Indian Museum material, except for the specimens of *V. dissimilis* (Müll.), the species from the Loktak Lake and the extra-Indian species, was specially preserved for histological work. In the case of fresh material specimens were fixed in absolute alcohol, corrosive acetic solution with or without acetic, 5 per cent. formalin (neutralized), Zenker's fluid, Flemming's fluid weak and strong both with and without acetic, Hermann's fluid and Bouin's fixative.

Sections of the embryos were cut after double embedding in celloidin and paraffin according to the method described by me already.¹ For all other work the sections were prepared in the usual way after embedding in paraffin only. The sections of embryos were cut 3-4 μ thick, while the other sections ranged between 5-8 μ .

Only in exceptional cases was the material stained *in toto* before sectioning; the stains used being Grenacher's borax-carmin or Ehrlich's haematoxylin. In the case of sections stained on the slide Delafield's haematoxylin followed by eosin or Orange G. was usually employed. For all critical work and for tissues fixed in Osmic mixtures Heidenhain's iron haematoxylin and Dobell's iron haematin were used; the former of these gave the most satisfactory results. For embryological material Heidenhain's stain was found to be the most useful. For the differentiation of muscle fibres from connective tissue van Gieson's stain and its various modifications, and Mallory's stain were used. Specific stains like Methylene Blue, Mucicarmin, Thionin and Toluidin Blue were employed for differentiating the glandular areas. For the identification of calcareous particles, whether in the form of calcium carbonate or as calcium phosphate, I used Roehl's haematoxylin, purpurin, alizarin, Macallum's lead acetate and Cossa's silver nitrate method of micro-chemical reactions; full details of these methods will be found in Zill's paper (179). Of these Roehl's haematoxylin, purpurin and Cossa's silver nitrate stains were found to be useful, but really critical reactions were seldom obtained. The tissues used for these micro-chemical tests were fixed

¹ Prasad, B.—*Ind. Journ. Med. Research*, V, p. 611 (1918).

in acid free solutions like neutralized formalin 5 per cent, corrosive sublimate solution without acetic, or absolute alcohol.

For the structure of the shells broken pieces of shell were examined, and in addition thin sections of shells were prepared by grinding on stones of various grades; the method employed being the one recommended by Flössner (51). Another method, which was found to be very helpful, was worked out in the Geological Institute of the University of Frankfurt a. Main, with the help of Herr A. Schwarz. Small pieces of shells varying in size from $\frac{1}{4}$ - $\frac{1}{2}$ an inch in length and about a quarter of an inch in height were cut in the right plane by means of a steel saw, and embedded in Kollolith on a slide. The surface of the shell was carefully polished after all scratches and uneven areas had been smoothed by grinding, and the preparations were afterwards left in very dilute acetic acid (5 drops to 200cc.) for etching the surface. The etching was controlled under the microscope. Such preparations could, of course, only be examined by reflected light or very low powers of the microscope, but were found to be very useful for interpreting the structures.

For the drawings of my paper I am indebted to Frau Dr. Winter of Frankfurt, who prepared the same under my guidance with great skill and infinite patience. The microphotographs were mostly taken at Wetzlar, Germany, in the beautifully equipped microphotographic section of the well known optical works of Messrs. E. Leitz, and it is my very pleasant duty to record my great indebtedness to Dr. E. Leitz for unreservedly placing the resources of his works at my disposal during the time I was working there.

3. THE SHELL AND THE ANIMAL.

Stempell (162) has published a detailed critical summary of the literature dealing with the different views regarding the formation and the growth of the shells of molluscs, and it is not necessary, therefore, to repeat the same here. It may, however, be noted that recent work on the structure, formation and regeneration of shells has fully confirmed Réaumur's view (137, 138) of the growth of shells by *apposition*, and there is no justification for believing that growth of any shells whatsoever takes place by *intussusception*. The shells are the secretion products of the animals they enclose, and have no separate existence of their own. They can not increase in size except by the addition of fresh material secreted by the animal.

The animals and shells of molluscs were from quite early times supposed to be closely connected, but it was not till the announcement of Réaumur's experiments of 1709 (137) that the exact relation between the two was understood. Réaumur described the organic layer of the shell, corresponding to what is now known as the periostracum, as a secretion of the animal, and considered it as a mould on the inner surface of which the calcareous secretions were deposited in layers.

Bournon (13), as a result of his investigation of the shell structure of various Gastropods, stated that the shell layers were probably formed by crystallization of shelly secretions of the animal deposited in succession on the inner surface of the organic periostracum.

Gray (64), referring to the opinion of the earlier authors on the secretion of the shell by the mantle of the animals, remarked that the operculum and the shell of *Cymbia*, *Oliva*, *Ancellaria* and many other genera of Marine Gastropods is secreted by the upper surface

of the foot. Philippi (130), Tullberg (169) and Cooke (30) also refer to the role of the foot of Gastropods in the formation of the shell, but this is apparently based on the remarks of Gray referred to above, and has not been confirmed by any recent work. It may, therefore, be safely concluded that the shell of the Gastropods is a secretion of the mantle, and that the increase in size and thickness can only take place by the deposition of fresh material on the already existing shell. I do not include in this general statement the secondary changes which are brought about in the shells of the Cypræidae, the Auriculidae and other forms by the dissolving away of some of the earlier whorls.

Picard (131) appears to have been the first to differentiate definitely between the increase in size (en l'élongation) and the thickness (en épaisseur) of the shell. He distinguished the regions which secrete the shell in the two cases, and noted that the thickness of the shell resulted from the deposition of new layers by the epithelium of the mantle inside the already formed shell.

Bowerbank (18) considered the shell to be highly organised and vascular in structure, and added that it retained a vascular connection with the animal throughout life. With reference to the cellular nature of the shell he did not specify the area which secretes the membrane in which later the cytoblasts of the shell were supposed to develop.

Carpenter (25) could not find any vascular connection of the type described by Bowerbank, but agreed with the latter author regarding the cellular nature of the shell. He made no reference to the parts of the animal by which the shell is secreted.

In the mantle margin of the common garden-snail of Europe Meckel (114) described a very large number of small glands opening by minute pores. These glands, according to the author, are flask-shaped, and their slimy secretion contains large quantities of calcareous material for the formation and repair of the shell. He described the mantle epithelium as consisting of columnar cells in which also he found the calcareous granules.

Gegenbaur (61) described the process of shell formation in the mantle furrow of the embryos of some Pulmonates. He did not mention any glands in the furrow and it may be assumed that he believed the secretion of the shell to be confined to the epithelium lining the furrow.

Semper (152) considered the share of the mantle epithelium in the secretion of the organic part of the shell of Gastropods, and more particularly in the Pulmonates, as quite insignificant. In the thickened mantle margin he found large numbers of two kinds of mucous glands to which he assigned the secretion of the cuticular layer of the shell. He considered the epithelium on the surface of the thickened mantle margin to be too insignificant to have any share in the secretion of the organic part of the shell. The calcareous material of the shell was believed to be secreted through the epithelial cells of the mantle, apparently from the subepithelial connective tissue.

Leydig (103) referred to his earlier observations (102) on the shell in the embryos of *Viviparus*, where he suggested its secretion by the skin epithelium, (Hautepithel, apparently implying thereby the mantle epithelium). He was of the opinion that the calcareous part of the shell is deposited as polygonal particles on the inner surface of the cuticular shell. He considered the mantle margin as the area mainly responsible for the growth of the shell owing to the brownish pigment in the epithelial cells of this region being confined to zones

which correspond exactly to the pigment bands of the shell. He agreed with Semper that the calcareous glands in the mantle do not play any important part in the formation of the shell, but that the calcareous fluid for the formation of the shells oozes (schwitze) out through the epithelial cells.¹

Nalepa (124) described intercellular spaces between the epithelial cells of the mantle of *Helicidae*, through which he believed that the calcareous fluid from the blood-spaces in the connective tissue was directly conveyed to the exterior. These spaces were definitely denied by Moynier de Villepoix (121), while Burkhardt (22), who found some spaces particularly between the epithelial cells of the visceral mass, considered them as secondary modifications of no particular significance.

Tullberg (169) figured and described a mass of flask-shaped unicellular glands in the mantle margin of *Buccinum undatum*, but was doubtful as to their function. He suggested that they probably secreted the periostracum, but, in view of the secretion of the rest of the shell by the general mantle epithelium, he was doubtful that special glands should have been differentiated for the secretion of the periostracum. Dakin (32) confirmed the presence of the glandular mass in the mantle margin of the whelk, but made no mention of any pallial groove in his account. Owing to the absence of the glandular mass in the region of the mantle below the visceral mass, where no periostracum is formed, Dakin suggested that this area probably, as supposed by Tullberg, secreted the periostracum.

Longe and Mer (107), in land-snails and especially in *Helix*, found a peculiar modification of the anterior margin of the mantle in connection with shell secretion. They described an "appareil cutogène" consisting of a groove (sillon palléal) running parallel to the mantle margin, and a band of goblet-shaped epithelial cells (organe épithélial) behind the groove. At the bottom of the groove they found a large number of gland cells, which were supposed to secrete mucus in the form of conchiolin, while the goblet cells of the epithelial organ contained granules soluble in caustic potash but not in acids. The secretions of both these areas were supposed to form the periostracum of the shell. The deeper shell layers were believed to be secreted by the general surface of the mantle. The mantle margins show this modified structure till the snail is full-grown, when the goblet-shaped cells of the epithelial organ and the glands at the base of the groove atrophy; the groove itself, however, persists throughout life.

Nalepa (123) referred to the pallial groove having been observed by the earlier workers and described the structure of the mantle margin of *Helix arbustorum*. He found the band of goblet-shaped cells behind the groove, and, according to him, the cells are fully developed only during the period of growth. Like Longe and Mer he was of opinion that the cuticle of the shell is secreted by the cells of this band and the gland cells of the mantle furrow. The epithelium of the furrow, according to Nalepa, does not differ from that of the rest of the surface of the mantle. He added that the epithelium behind the band of goblet-shaped cells is generally absent or consists only of very young cells, and stated that this is probably connected with the secretion of calcareous substance by the connective tissue cells lying below it.

¹ Various views have been held by different authors regarding the sub-epithelial mucous, calcareous and pigment glands of the *Gastropods*, and detailed accounts of these will be found in the recent papers of Herfs⁷²) and Zill (179).

Moynier de Villepoix (120, 121) in his monumental works laid the foundation of our knowledge of the mantle margin and its relation to the secretion of the various shell layers. In the mantle margin of *Helix* he described a deep furrow ("gouttière palléale" corresponding to Longe and Mer's "sillon palléal") to which and the glands at the bottom of the furrow he attributed the secretion of the periostracum. Behind the furrow he distinguished the pallial band ("bandelette or glande palléale" corresponding to the "organe épithélial" of Longe & Mer) consisting of flask-shaped gland cells which secrete the outer calcareous layers of the shell. To the general epithelium of the mantle lying behind the pallial band was, as by the earlier workers, assigned the secretion of the internal layers of the shell and the pigment for the shell. Biedermann (6), as a result of his studies on the structure of the shells of various Gastropods and the mantle of *Helix*, fully confirmed the work of Moynier de Villepoix. He concluded that the shells are formed by secretions of the epithelial cells of the mantle and probably also in part by the secretion of glands. The various layers of the shell differ in their structure and disposition from one another, and correspond to definite areas of the mantle by which they are secreted.

Meisenheimer (117) simply follows Moynier de Villepoix and Biedermann in his account of the shell secretion in *Helix*.

Burkhardt (22) investigated the structure of the mantle margin in *Helix pomatia* and came to the same conclusions as Moynier de Villepoix. Matthes (112) found the structure of the mantle margin of *Helix pisana* to be similar to that of *H. pomatia*.

Thiele (167, II) studied the shell of various molluscs in connection with the soft parts, and distinguished the three shell layers in it as periostracum, ostracum and hypostracum. In *Patella* and *Haliotis*, the mantle of which he specially studied, he did not distinguish any special zones in the mantle margin, but found a well developed groove running parallel to the margin. He remarked that only the epidermis of the mantle margin appears to be a derivative of the original (ursprünglichen) epidermis, while the epithelium of the visceral mass, which secretes the hypostracum, consists of modified connective tissue cells. Regarding the secretion of the Gastropod shells he agreed with Semper's view referred to above. Davis and Fleure (34) in the case of *Patella vulgata* found a large number of subepithelial glands near the edge of the mantle, which they stated secrete the outer shell layers.

Thiele's work on *Haliotis* was confirmed and extended by Fleure (50), according to whom the epithelium of the mantle furrow secretes the outer layers of the shell, while the inner shell layers are secreted by the "Haftepithel" and the cells adjacent to it on the upper surface of the mantle.

Haller (66) made contradictory statements about the mantle margin in *Docoglossa*, and it is not possible to understand his account of the secretion of the shell by the outer surface of the mantle margin and to correlate it with the histological structure of the area as described by him. In *Lottia* and *Scuttelina* he described two types of glands in the mantle margin, of these the upper series is described as consisting of unicellular, flask-shaped glands, while the lower series is shown as a large mass of greatly elongated and convoluted glandular sacs. As Haller had not been able to distinguish the nuclei in the sacs, Thiele (167, III) and Simroth (159) doubt as to whether his account can be accepted as correct, and Thiele definitely considers the glands as unicellular.

Jacobi (79) described the mantle furrow in *Amphidromus*. He regarded the furrow and the glands lining it as the apparatus for the secretion of the mucus which is found on the soft exposed parts of the animal. After a general review of the literature he assigned the secretion of the shell to the mantle as a whole.

Linden (105), without going into details, noted that there is a differentiation of the epithelium in the different regions of the mantle which secrete the various layers of the shell.

Simroth (159) gave a useful summary of the work of earlier authors, but omitted much of the recent work. He concluded that the upper or the outer surface of the mantle secretes the periostracum and the ostracum, while the rest of the mantle and the visceral mass epithelium secrete the hypostracum. In view of the contradictory accounts of Tullberg and Moynier de Villepoix, he was of opinion that our knowledge of the conditions in the higher Gastropods was not sufficiently advanced for exact demarcation of the different areas which secrete the various shell layers.

Stempell (162), in his valuable review of the literature on the formation and growth of the shell, paid little attention to the differentiation of the various areas in the mantle for the secretion of the different layers of the Gastropod shell.

Haeckel (65) could not distinguish any separate regions for the secretion of the various shell layers in *Chilina*, but found two kinds of glands evenly distributed in the mantle epithelium and was of opinion that these probably secreted the shell. In *Crucibellum* Scheidig (147) did not find any separate zones, but believed that the general epithelium of the mantle secretes the patelliform shell. Kleinstuber (85), as a result of his observations on *Trochita*, *Calyptraea* and *Janacus*, agreed with Scheidig and stated that in all these there is no differentiation of the mantle epithelium or of the glands for the secretion of the various shell layers.

Schumann (151) in *Gadinia*, Beck (5) in *Buliminus*, Küttler (91) in *Oliva*, Eckhardt (41) in *Vitrina*, Frank (57) in Trochidae, Wille (174) in *Stenogyra*, Weber (172) in *Cyclophorus* and Herfs (71) in *Cyclostoma* and *Amphipeplea* described the modification and demarcation of the different areas of the mantle margin for the secretion of the various layers of the shell corresponding to those in the Helicidae noted above. Bregenzer (19) did not describe the mantle margin of *Bythinella dunkeri* in detail, but from his figure of a transverse section of the mantle margin of this mollusc it is clear that the modifications of the mantle margin in this species also are similar.

Zill (179) stated that the subepithelial calcareous glands of the mantle have no share either in the formation or in the regeneration of the shell, but that both these functions are performed by the mantle furrow and the epithelium of the visceral mass. He does not mention the pallial band of unicellular glands situated just behind the mantle furrow.

A few observations on the much debated question of the origin of the unicellular flask-shaped gland cells may also be included here. Flemming (46) considered the cells to be derived from the connective tissue cells, but later (49) was of opinion that they are only modified epithelial cells. Simroth (156), Hoyer (78), Jacobi (79) and Plate (132) derive them from connective tissue cells. Leydig (103) considered the pigment and calcareous gland cells to be subepithelial in origin, while the other gland cells were believed to be modi-

fied epithelial cells. Boll (11), Techow (165, 166), Burkhardt (22) and Herfs (71, 72), on the other hand, consider them all to be modified epithelial cells.

From the above review of the literature it is clear that the mantle is the only structure that, with our present knowledge of the anatomy and histology of the Gastropods, can be definitely considered as responsible for the secretion of the shell.

My own observations are in agreement with this view ; I have not been able to trace any connection between the shell and any other organ in the Viviparidae, and the present work is, therefore, limited to the structure of the mantle margin in various members of the family. The general epithelial covering of the mantle and the visceral mass which probably secretes the innermost layers of the shell is only casually considered here.

4. THE MANTLE OF THE VIVIPARIDAE.

I. Previous accounts of the structure of the Mantle Margin.

In the historical works of Swammerdam¹ (164) and Lister (106) there is no reference to the structure of the mantle or its relation to the secretion of the shell in *Viviparus*. Cuvier (31) generally described the mantle of *Viviparus*, but did not mention any processes on its margin, and made no remarks about the shell-gland area in it. Leydig (102), in his monograph on the anatomy and embryology of *V. viviparus* (Linn.), did not devote much attention to the mantle except to its condition in the embryo. In the adult the margin of the mantle, according to his account, is uniform (ganzrandig), and does not show any traces of the embryonic processes. He does not refer to any ridge or groove running parallel to the mantle margin, and did not distinguish the shell secreting glands. In the embryo, however, without understanding their true nature, he described the calciferous glands as "dann erkannte ich bei Embryonen hinter den drei fingerförmigen Forsätzen des Mantelrandes gelbliche, cylinderförmige Drüsenschläuche von 0,05''' Länge und 0,008-0,0120''' Breite, welche mit zelligen Inhalt angefüllt waren, am verdickten Mantelrand des erwachsenen Thieres aber konnte ich diese Drüsen nicht mehr auffinden, so dass es den Anschein hat, als ob sie zugleich mit den Mantelfortsätzen verschwänden." Speyer's thesis (160) is mainly anatomical, but the author included a general description of the mantle, and distinguished in it the cells which secrete the pigment and the shell ; the structure of the cells is very imperfectly described and the exact limits of the shell gland were not distinguished. He did not distinguish the mantle ridge or the groove in the margin of the mantle, and in the description of the embryos made no reference to the processes on the mantle margin. Bouchard-Chantreaux (12) and Moquin-Tandon (118, 119) referred to the mantle of the adult *Viviparus* only casually, and, like the authors mentioned above, did not distinguish the mantle ridge or the groove ; they also make no reference to the shell gland area of the mantle.

Moynier de Villepoix (122) in his criticism of Longe & Mer's paper (107) referred to the mantle of *Viviparus*, and remarked that the ridge and furrow along the mantle margin of *Helix*, which he had named "bandelette or glande palléale" and "gouttière palléale" res-

¹ Swammerdam's work on *Viviparus* was completed about 1670, though *Biblia Naturae* was not published till 1737, 67 years after his death. The species of *Viviparus*, so far as can be judged from the figures in his work, and which are reversed in reproduction, was *V. fasciatus* (Müller).

pectively in his earlier papers (120, 121) are also similarly developed in the mantle margin of *V viviparus*.

Sewell (154) described the condition of the mantle in the adult *V bengalensis*, the common Indian Banded Pond-snail, and found that traces of the embryonic processes of the mantle can be recognised even in the fully developed adults. Of the processes, the one opposite the commencement of the gill is specially marked, while yellow pigment splashes on the mantle margin, according to the author, "possibly denote the former positions of the others that have since disappeared." The mantle ridge or the "bandelette palléale," he called the shell-gland, but did not, in view of the detailed paper by Annandale (1), which immediately followed his own, describe the structure of the mantle margin. Annandale in the paper cited published a detailed histological account of the margin of the mantle, and devoted a great deal of attention to the glands which secrete the shell and the mantle processes; these latter are discussed separately (p. 264). His account is, unfortunately, incorrect in many details and I have thought it best to include here extracts from the author's summary rather than offer a summary of my own. On the dorsal surface of the margin of the mantle he designated the so-called "white-band" of earlier authors by the more appropriate name of "supramarginal ridge." This structure in other Gastropods, as remarked already, has been called "bandelette palléale" by French and "Drüsenpolster" by German authors. In front of and running parallel to the supramarginal ridge he found a groove which he labelled "supramarginal groove." This groove is the "sillon palléal" "gouttière palléale" or "Mantelfurche" of other Gastropods. In passing he noted the distribution of the ciliated and non-ciliated epithelium on the upper and the lower surfaces of the mantle, and described the musculature of the marginal region in detail. He included a few remarks about the connective tissue part of the mantle. He did not describe the cells or glands which secrete the nacreous layer but believed that this is "probably affected by unicellular glands scattered over the whole of the upper part of the mantle." Regarding the other glands which secrete the periostracum and the main calcareous part of the shell, he distinguished two types, (i) the periostracal, and (ii) the calciferous glands. The structure of the periostracal glands is summed up by him as follows:—"true multicellular glands of a vermiform shape, consisting of contorted tubules and opening to the surface by ducts with cellular walls. They lie some distance below the external surface in a transverse series along the extreme margin, for the most part beneath (*i.e.* distad of) the calciferous glands and with the main axis of each gland at right angles to the margin. Their ducts open into the supramarginal groove." I have carefully examined large series of sections of both embryos and adults of different species preserved in various fixatives during different periods of their activity, but have failed to find glands of the type described by Annandale. Further, no such glands are known in the mantle region of any other family of Gastropods. There are no multicellular glands in the region of the mantle-groove, and, so far as I can see, the author must have mistaken some parts of the calciferous glands for the structures he described. The calciferous glands, according to the author, are "much more bulky and differ considerably in structure. They occupy the supramarginal ridge and as a rule extend slightly beyond it both above and below, lying only a short distance beneath, or actually on, the surface and having no cellular ducts. Like the periostracal glands they form a transverse series, though the main axis of each gland is at right angles to the margin. Each

gland is at first an elongate cylindrical tubule of gland cells forming a large number of closely and adpressed loops in the external margin of connective tissue. The cells are large and do not appear to have any intimate organic connection *inter se*. The lumen of the tubule has no special lining. At this stage ducts, perhaps of a temporary nature, can be detected in sections, but they form mere gaps in the epithelium, leading out from ill-defined spaces beneath it (fig. 2, Pl. iii). Later the gland cells become greatly enlarged and elongate and open direct on the external surface; while the tubular character of the glands disappears." This description of the structure of the glands is not accurate; the author apparently did not understand their true nature, *i.e.*, that they are composed of unicellular gland cells.

Herfs (71) published an account of the histological structure of the mantle of *V viviparus* about the same time as the paper by Annandale and apparently without having seen it. His object in studying these structures was to decide the origin of the gland cells of the mantle-ridge and he does not deal with the rest of the mantle in any detail. The cells when fully developed appear subepithelial, but Herfs from his study of sections of the young of *V viviparus* concluded that they are true epithelial cells which sink down into the subepithelial region, and added that in sections one can actually follow the gradual passage of the cells from the epithelial to the subepithelial region. Moynier de Villepoix had previously (121) arrived at the same conclusions for *Helix*. He further attempted to homologize the glandular areas in the mantle of *Viviparus* with those of *Helix* and other Gastropods. According to him it is hard to distinguish definitely the various areas which secrete the different layers of the shell, and he had no observations to offer on the subject. By analogy, however, he distinguished with Moynier de Villepoix (121) and Biedermann (6) the periostracal gland region in the mantle-groove and possibly also in the marginal zone of the mantle in front of it. For the calciferous gland he referred to the uncertainty expressed by Simroth (159) regarding the main glandular area in the Prosobranchs being homologous with that of forms like *Helix*, but still was of opinion that the gland-region in *V viviparus* is quite like the "bandelette palléale" or "Drüsenpolster" of *Helix aspersa*, and probably here also forms the region by which the main calcareous part of the shell is secreted. His description of the cells though not sufficiently detailed is accurate. He further observed that the gland cells in the white-band area of the mantle are only seen in young individuals and are confined to the regions in which the shell is being secreted. In the adults on the other hand there are no deep-seated glands and the tall epithelial cells lie entirely in level with the other cells of the epithelial band.

II. *The Processes of the Mantle Margin.*

Bouchard-Chantreaux (12) was the first author to observe the development of processes on the margin of the mantle of the fully formed embryos of *Viviparus viviparus*. He described the processes as "trois petites lobes triangulaires du bord du manteau, qui ont environ un millimètre de longueur, et sont toujours renversés sur la coquille; ils sont situés à la place où seront plus tard les trois bandes noires qui ornent ce manteau, et dont une seule commence à se former, les deux autres n'étant encore annoncées que par des petites taches grisâtres plus ou moins éloignées les unes des autres, mais rangées sur une même ligne." He further noticed that with the growth of the embryos these processes, which form the hairs (poils) on the surface of the three carinae of the embryonic shell, became gradually

reduced and finally disappeared. In some cases the processes persisted, and in the adult animals could be distinguished as minute papillae opposite the colour bands of the mantle.

Moquin-Tandon (118) further extended the work of Bouchard-Chantreaux, and correctly described the position of the processes on the right side of the mantle margin. He hinted at a possible connection between the colour bands of the mantle and those of the shell and also between the mantle processes and the ridges on the shell. He further remarked that in exotic species of the genus *Viviparus* with a multicarinate shell, the mantle processes do not differ very much in number or size from those in *V. viviparus*. To the left of the three processes, noted above, he found on the margin seven small, irregular, teeth-like processes. In a later work Moquin-Tandon (119) gave a good summary of the previous work, but apparently in ignorance of the work of Leydig (102) to which he makes no reference, and added that the processes are found in the embryos of *V. contectus* (Millet) = *V. fasciatus* (Müll.); he does not make any remarks on the condition in the embryos of *V. viviparus*. He published a figure of the mantle margin, and stated that the processes were hollow, and had each an open channel in the mid-dorsal line.

Leydig (102), apparently independently of the works of the authors noted above, described the presence of three processes on the mantle margin of the fully formed embryo. According to him the embryo, while still in the uterus and enclosed in the egg membrane, develops along the right side of the mantle margin three wart-like processes; these later elongate and become finger-shaped. The processes were further found to be contractile, and Leydig definitely connected the processes with the formation of the hairy ridges on the embryonic shell.

Erlanger (43), in his detailed account of the embryology of the same species, did not refer to the processes of the mantle in the body of the paper, but in fig. 9 (Pl. xxii), which represents a fairly advanced embryo, he showed four almost equally developed processes arising from the right side of the mantle margin; these he called "fingerförmige Ausstülpungen des rechten Mantelrandes" or the finger-shaped evaginations of the right side of the mantle border. Lankester (100), Bütschli (23), Drummond (40), Tönniges (168) and Otto and Tönniges (126) do not refer to the processes in their account of the embryology of *V. viviparus*.

Annandale (1), who in connection with the development of the sculpture of the shell studied the structure of the mantle in the Viviparidae, noted that the processes of the mantle are present in a large number of species of the family belonging to a number of distinct genera found in different parts of Asia. Regarding the common European species *V. viviparus* and *V. fasciatus*, he does not say anything as to the condition in the former beyond referring to Leydig's figure, but in the case of *V. fasciatus*¹ he found that the processes are as well developed as they are in any of the Asiatic species. He gave an admirable account of the gross structure of the processes, and designated the three processes first noticed by Bouchard-Chantreaux, the "Primary Processes." He also found other similar processes developed in between and to the left of the primary processes, and called these "Secondary" and "Tertiary" processes. The outermost primary process on the left side he distinguished as the "Peripheral," while the other two were simply designated first and second. The peri-

¹ This species is referred to as *V. contecta* (Millet) in Annandale's paper.

pheral process, which is usually the most prominent, was according to Annandale morphologically the youngest, but played the most important part in the orientation of the shell sculpture. He further remarked that the processes "are not mere projections of the margin but organs with a definite form, position and function." In the mid-dorsal line of the processes he described a groove—the marginal groove—which was found to be connected with the supramarginal groove of the mantle margin. In his second paper Annandale (2) published further details about the primary and secondary processes in highly sculptured species of the Burmese Viviparid, *Taia* Annandale. The details were based on a study of living material, and as a result he was able definitely to assign the function of moulding of "the chaetae which ornament the shell in spiral rows, at any rate in the younger stages of its growth" to the processes of the mantle. In full grown shells of the sculptured species of *Taia* he considered them to correspond in position to the three main spiral ridges, but owing to their small size he did not think that they had any real influence in moulding the actual ridges. As to the processes in the embryos of the Viviparidae as a whole he now qualified his view of their occurrence in all the Viviparidae with the remark "which in a few species are perhaps alone present."

III. *The Structure of the Mantle Margin of the Viviparidae.*

(a) *Terminology.*

To make the terminology employed clear and to avoid repetition, I will preface the account of the structure of the mantle margin with a description of the terms I have used. In the following account I have adopted most of the terms proposed by Annandale (1), but in some cases it has been necessary to introduce fresh names. In place of the expression Marginal Region of the Mantle or its abbreviation Marginal Region suggested by Annandale, I use Mantle Margin for the anterior free edge of the roof of the pallial cavity. The term Supramarginal Ridge (Pl. xx, fig. 1, *S. R.*) is used for the thickened, glandular, band-shaped area which runs parallel to and at a short distance from the free edge of the mantle in its upper or dorsal part; it is usually of a different colour from the rest of the mantle. As in other Gastropods, the mantle, in this family also, forms a more or less complete envelope round the anterior part of the animal. In most species the ventral portion of the mantle consists of only a narrow pigmented band. In this region the area corresponding to the supramarginal ridge is continuous with the free margin and there is no trace of the groove in front of it. Immediately in front of the supramarginal ridge is a shallow canal—the Supramarginal Groove of Annandale (Pl. xx, fig. 1, *S. G.*)—running all along the mantle margin. The mantle margin of the embryos, and in some cases of the adults also, is produced into wart-like or finger-shaped projections; these are designated as the Marginal Processes (Pl. xx, fig. 1, *M. P.*). As has been remarked already Annandale distinguished these processes as Primary, Secondary or Tertiary, according to the probable sequence of their origin, and the degree of their development. The primary processes from their positions on the right half of the mantle margin I distinguish as the Sutural, Median and Peripheral respectively. Of these the sutural is the outermost process on the right side and lies near the suture of the shell, the peripheral lies opposite the periphery of the bodywhorl of the shell and more or less marks the dividing line between the right and the left half of the upper part of the

mantle, while the median lies between these two processes. The processes are channelled in the mid-dorsal line, and this shallow channel or groove, Annandale's Marginal Groove, I term the Groove of the Processes. It begins in the supramarginal groove posteriorly and anteriorly ends freely near the mantle margin.

(b) *Macroscopic Structure.*

In the following account I propose to deal with the structures in the various subgenera of the family separately, and shall also, where possible, include notes on the mantle margin of the embryos of different stages.

Viviparus Montfort.—In the description of the different forms of this heterogeneous subgenus I will give a detailed account of the mantle margin of the common Indian Banded Pond-Snail—*Viviparus bengalensis* (Lam.)—and indicate the main differences in the various groups of this subgenus.

In fairly young embryos of *V. bengalensis* while still enclosed within the egg envelope, the mantle margin shows the three primary processes on the right side (Pl. xxi, fig. 1) traces of two or three secondary processes are also to be seen on the left side. The edge has a very narrow band of black pigment interrupted in the region of the processes; it is shown as a black line in the figure. The supramarginal ridge, which is very prominent, is, at this stage, very broad and appears of a creamy colour. The supramarginal groove is very narrow and hard to distinguish; its position is indicated in the drawing by a thin line. It is, however, easily to be seen where the grooves of the processes originate from it. The three dark pigmented bands on the region of the mantle lying posterior to the supramarginal ridge on the right side of the mantle of preserved specimens appear as if they alternate with the primary processes. This is, however, a result of fixation, for in the living specimens they are seen to lie opposite the processes and underneath the colour bands of the shells.

In a specimen the shell of which is about half an inch in length, the mantle margin in front of the supramarginal ridge is much broader than the ridge itself. It appears uniformly dark, and only the grooves of the processes in this region are seen as white lines. The supramarginal groove and the ridge (Pl. xxi, fig. 2) are both quite distinct, and the ridge is seen to be rather narrower laterally. In preserved specimens no distinct colour bands can be distinguished on the posterior region of the mantle, and the pigment appears to be uniformly suffused. Some specimens, however, show slight differences in the intensity of the pigment in different regions and the mantle appears banded. The three primary processes, of which the peripheral is usually the best developed at this stage, are quite prominent, and a number of secondary and tertiary processes are also to be seen.

In a full-grown specimen, as has been described by Annandale (1) and Sewell (154), the marginal processes are indicated by the wavy margin of the mantle and the different colouration of the areas corresponding to the processes. The supramarginal ridge and the groove are both distinct, but the former is not so distinct as it is in the earlier stages. Its development further varies with the degree of activity of the shell secreting areas and the state of preservation of the specimens, but I have not come across any specimen in which the two structures had entirely disappeared.

In *V sumatrensis* (Dunker) the mantle margin is similar to that of *V bengalensis*, except that in the adult the margin shows a number of distinct processes, and the supramarginal ridge and groove are more clearly indicated.

In *V viviparus* (Linn.) the embryos show the primary processes for a short period of their embryonic life, but they are then very minute (Pl. xxi, figs. 3, 4). This apparently is the reason of their having been overlooked by most of the recent workers on the embryology of this mollusc. In fully developed embryos traces of the processes are sometimes to be distinguished by the remains of the grooves of the processes, but the processes as such disappear before birth. In the adult mantle margin even the traces of the grooves are no longer visible, but otherwise the structure is similar to that of *V bengalensis* described above. In species of the group of *V fasciatus* (Müll.) and allied forms the primary processes are well developed and are distinctly finger-shaped. The mantle margin of an embryo of *V pyramidalis* (Jan.) Rossm. is figured (Pl. xxi, fig. 5), and the condition in *V fasciatus* and *V duboisiana* (Mousson) is very similar to it. The mantle margin of the adults of all these species is similar to that of *V viviparus*, but the supramarginal ridge and groove are better developed, and in some young specimens traces of the grooves of the processes also remain.

Viviparæ Dissimiles Group.—The embryonic mantle margin of *V dissimilis* (Müll.) has been described by Annandale (1), who in living specimens found four secondary and a number of tertiary processes in addition to the three primary ones; the situations of the processes were observed to correspond to the ridges on the embryonic shells. In a preserved very young embryo (Pl. xxi, fig. 13), I found the three primary processes on the right half of the mantle, and two secondary ones on the left half. In older specimens the condition resembled that described by Annandale, and remains of some of the processes were to be distinguished on the mantle margin of the adults as well (Pl. xxi, fig. 14). In *V quadratus* (Benson), *V delavayana* (Heude), *V sclateri* (Frauenfeld), *V javanica* (v. d. Busch) and *V laevigatus* (Bavay) the structures are similar to those of *V dissimilis*, and the only difference to be noticed is in the degree of development of the processes. In strongly ridged species like *V quadratus* (Pl. xxi, fig. 15) and *V sclateri* the primary processes are all equally well developed and are distinctly finger-shaped. In *V delavayana* (Pl. xxi, fig. 12), which has many rather feeble and almost equally developed ridges, only the peripheral primary ridge is well developed, but a number of secondary ridges and the sutural and the median are indicated by their grooves.

Viviparæ Unicoloræ Group.—The two species of this group, *V unicolor* (Olivier) and *V sambesiensis* Sturany, which I have examined, are similar to *V dissimilis*. In a very young embryo of *V sambesiensis* (Pl. xxi, fig. 28) the three wart-like primary processes are developed on the right side. I, unfortunately, had no older embryos of this species, but embryos of *V unicolor* were almost identical with those of *V dissimilis* referred to above. In the adult of *V unicolor* also the condition is similar to that of *V dissimilis*, but in the case of *V sambesiensis* (Pl. xxi, fig. 29) which has a large number of feebly developed, low ridges on the shell, there are numerous subequal processes to be seen all along the margin.

Cipangopaludina Hannibal.—I have examined spirit material of a number of species of this subgenus from such widely separated areas as India, China, Amur Basin and Japan, and find that the conditions are very uniform in all the species. In young embryos (Pl. xxi,

figs. 9-11) the three primary processes are strongly developed. In older embryos, however, only the peripheral (Pl. xxi, fig. 8) remains as a distinct process, while the others, which are probably less functional, are indicated only by the remains of their grooves; traces of some secondary and tertiary processes are also to be seen on the left half of the margin. The supramarginal ridge and groove are, however, better developed than in *Viviparus*. The adult mantle margin is very similar to that of the fully grown embryos, but the peripheral process also becomes much less distinct and is apparently functionless.

Neothauma Smith.—In young embryos the mantle margin (Pl. xxi, fig. 30) shows the three primary processes. The median is rather feebly developed, and traces of some secondary processes are also to be distinguished. The adult mantle margin, in the specimen examined, did not show any processes, but remains of some as grooves were to be seen. Corresponding to the well developed sutural and peripheral ridges of the shell there are distinct longitudinal thickenings of the mantle such as are found in the case of *Dactylochlamys* described in detail below.

Dactylochlamys Rao.—The shells of this subgenus are highly specialised in that they are ornamented with spiral, continuous ridges. The ridges vary in the degree of their development, being only low ridges, or fairly raised structures channelled out throughout their extent, or they are quite solid. The mantle margin of the adults of the various members of this subgenus is correspondingly specialised, though probably it would be more correct to describe it as having retained its embryonic characteristics much more than is the case with any other members of the family.

In *D. oxytropis* (Benson), a species with well developed, hollow ridges on the shell, even the very young embryos (Pl. xxi, fig. 19) show the three finger-shaped primary processes, and traces of a number of secondary and probably tertiary processes, indicated by their grooves, on both the right and left half of the mantle margin. In addition to the processes there are three rather low ridges corresponding to the primary processes and running backward from them on the surface of the mantle; these apparently serve as the moulds for the hollow primary ridges of the shell. In the adult (Pl. xxi, fig. 20), the primary processes remain as definite processes, and some of the secondary and tertiary processes also persist, though from preserved material only it is not possible to lay down exactly the positions of those which remain as definite structures throughout the life of the animal. Of the longitudinal ridges on the surface of the mantle the sutural persists as a definite structure, but the others are only faintly indicated.

D. tricostatus (Lesson), *D. burroughiana* (Lea.), and *D. ussuriensis* (Gerstfeldt) are similar to *D. oxytropis*, and only differ in the degree to which the processes persist in the adult. All the three species are at a lower grade of evolution regarding the development of the ridges than *D. oxytropis*, and corresponding to the feebly developed ridges on the shells of these species the processes of the mantle margin and the ridges on the surface of the mantle are also less well developed.

In *D. costatus* (Quoy and Gaimard) the embryonic mantle margin (Pl. xxi, fig. 26) shows three well developed finger-shaped primary processes. The adult mantle margin (Pl. xxi fig. 27), corresponding to the many low, almost equally developed and not very channelled ridges of the shell, has a large number of subequal processes. In the poorly preserved

material before me it is not possible to distinguish the primary processes except by their position. The edge is, as shown in the figure, distinctly furrowed, and this appears to correspond to the channels of the shell.

In *D. lanaonis* (Bartsch) var. *iota* (Bartsch) the structures are similar to those in *D. oxytropis*, but the processes, both in the embryos and in the adults, are not so well developed. In a young embryo of the typical form of *D. lanaonis*, which has a more ridged shell than that of var. *iota*, the embryonic mantle margin (Pl. xxi, fig. 21) shows three distinct primary processes (1-3), and continued backwards from these on the surface of the mantle are three ridge-like thickenings (*R*) corresponding to the hollow ridges of the shell. In var. *theta* (Bartsch) the processes and the ridges are both less strongly developed (Pl. xxi, fig. 23). The mantle margin of the typical form of *D. lanaonis* (Bartsch) shows in the case of the adult specimens (Pl. xxi, fig. 22) the highly contracted primary processes and remains of some other processes, while the ridges on the surface of the mantle, corresponding to the well developed ridges of the shell, are strongly marked. In the embryos and adults of *D. pagodula* (Bartsch) the conditions are similar (Pl. xxi, figs. 24, 25), except that the ridges are better developed, and the peripheral is the most prominent of all.

Margarya Nevill.—I have had only a portion of the mantle margin of an adult of *M. melanooides* Nevill in a poor state of preservation, and am, therefore, unable to describe in detail the condition in this subgenus. The arrangement of the supramarginal groove and ridges is similar to that in other members of the family, and traces of processes indicated as grooves could also be distinguished.

Taia Annandale.—The conditions in both living and preserved material of various species of this subgenus have been admirably described by Annandale (1, 2), and I have nothing to add to his account except to confirm it in all details.

Tulotoma Haldeman.—The mantle margin of the embryo (Pl. xxi, fig. 32) shows three primary and a number of secondary and tertiary processes. Corresponding to the strong development of the median ridge in this subgenus the median process is better developed, and the peripheral lies further to the left and below the periphery of the shell; this latter process is also less strongly developed. In the adult mantle margin (Pl. xxi, fig. 33) the processes are only feebly indicated in preserved specimens, but the ridges on the mantle surface running backwards from the processes are well developed; in the figure only the sutural and the median are shown.

In the poorly preserved material of the North American types *Campeloma* Rafinesque and *Lioplax* Troschel, I have not been able satisfactorily to make out the processes in the adults. Unfortunately none of the specimens before me are gravid, and I am, therefore, unable to add anything about the conditions during the embryonic life. The arrangements of the supramarginal ridge and groove in these forms are similar to those in other Viviparidae. Traces of grooves were made out in the adult mantle margin in some specimens, which would indicate that probably they also, like other members of the family, develop processes on the mantle margin during the embryonic stages.

Rivularia Heude.—I had no spirit material of this interesting subgenus, but a dry animal aken out of the shell and softened in spirit-glycerine showed the same arrangement of the supramarginal ridge and groove as other members of the family.

Cleopatra Troschel.—In the material at my disposal there are no gravid individuals, and my notes on this genus are very fragmentary. The structures in the mantle margin of the adult are arranged in the same way as in other members of the family. In some whole mounts and sections of the mantle margin grooves, probably corresponding to the processes of the margin, were distinguished.

Summary.—From the above account of the macroscopic structure of the mantle margin of both embryos and adults of different members of the family Viviparidae, it is clear that the arrangement of the shell secreting areas, the supramarginal ridge and groove, and the general surface of the mantle, is more or less uniform. It corresponds exactly to that of the various other Gastropods in which it has been investigated, and the only important difference lies in the development of special processes on the margin of the embryos, some of which also persist in the adults. The embryonic mantle margin develops three primary and a number of secondary and tertiary processes, which are channelled in the mid-dorsal line, and communicate through this groove with the supramarginal groove of the mantle margin. The processes correspond to the ridges or the sculpture on the shells of these snails, and either disappear entirely during or after the embryonic life, or persist in varying grades of development in different members of the family. In addition to the processes special thickened ridges are developed on the mantle surface of some of the sculptured forms, corresponding to the hollow ridges of the shells, and apparently serving as moulds for them.

(c) *Histological Structure.*

As this paper is mainly concerned with the shell-secreting areas of the animal the histological account will also be confined to the tissues which take part in the secretion and formation of the shell in the Viviparidae.

I have investigated the mantle margin of a large number of species of the family, and find that the general structure in all of them is uniform. The main difference is with reference to the areas occupied by the supramarginal ridge, the relative development of its glandular cells, and of the supramarginal groove. In the following pages I give a detailed account of the structures in *V. viviparus* and *V. fasciatus*, and refer only to the differences observed in other forms.

It may also be noted that in spite of the very large numbers of specimens of different species of all ages which I have examined macroscopically and by sections, I did not come across any individuals in which the supramarginal ridge had become fully degenerate, and resembled the condition mentioned by Herfs (71) for *V. viviparus* or as has been described by Moynier de Villepoix (121), Burckhardt (22) and other authors for *Helix*. This may be due to the animal and the shell not having reached the stage of maximum growth, and I believe that in Viviparidae, at least, this stage is not reached till very late in life. Animals of *V. sclateri* (Frauenfeld) for example, the shells of which were 48 mm. in length, still had a distinct supramarginal ridge, and the cells constituting it were as clearly differentiated as they are in the individual in which the shell is still to be secreted.

The structures as they are seen in the embryos taken out of the uterus of the gravid females will be described first and then as they are in the adults.

Supramarginal Groove.—In a young veliger even before the formation of the pallial cavity, the mantle fold develops a distinct groove on its dorsal surface behind the edge; this is the beginning of the supramarginal groove, and was given the name ‘Schalenfalz’ by Erlanger (43). As is seen in a vertical section of the embryonic mantle margin (Pl. xxiii, fig. 1), the groove is fairly deep and is lined by columnar epithelial cells. At this stage the groove is much more extensive than the supramarginal groove of the adult, and its cells gradually pass into those of the edge of the mantle on the one side and those of the supramarginal ridge on the other. In the younger stages the great extent of the area of the groove is correlated with the great activity in the formation of the periostracal shell. Later with the active development of the supramarginal ridge the area of the groove is encroached on and greatly reduced (Pl. xxii, figs. 1, 2). I am unable to state definitely whether any of the cells of the groove also are modified to form the ridge, but it appears as if they take part in its development. This would be quite in accordance with the facts when one remembers that there is no differentiation of the different areas in the early stages of the embryo, and that all the structures—the mantle, its margin, the supramarginal ridge and the groove—are differentiated from the everted embryonic shell-gland (*vide infra*, pp. 308, 309).

In the fully formed embryos the groove consists of a moderately deep channel (Pl. xx, fig. 2, *S. G.*), lined by rather narrow elongate columnar cells, in which the nucleus of the cells lies near the base of the cells. The cells pass gradually into the elongate cells of the supramarginal ridge on the inner side and the less elongate ones of the margin on the outer. The conditions are similar in the embryos of *V. fasciatus* (Pl. xx, fig. 6), *D. oxytropis* (Pl. xx, fig. 9), *Tulotoma magnifica* (Pl. xx, fig. 16), *Taia*, *Cipangopaludina* and other forms. In the adult the groove is much shallower, and varies in depth and in the depth of its constituent cells with the stage of activity of the cells. In individuals in a more or less active state of secretion, the cells (Pl. xx, fig. 3, *G. C.*) are elongated, being as much as 90μ in length, and the lower inner ends of the cells are slightly swollen. The nucleus is ovoid, and in a number of cells in which it was measured, it was $13\mu \times 5\mu$. There is a large nucleolus and a number of small chromatin granules irregularly distributed in the nuclear substance. The nucleus usually lies near the base of the cells, but in some of the younger unmodified cells which do not reach the basement membrane, it appears to lie about the middle of the layer. The protoplasmic contents seen in sections are reticulate and contain large numbers of minute granules. There are no pigment granules in any of those cells. The cells of the groove, whether along its outer or inner edge, are not ciliated, as was stated by Annandale (1); the region of ciliated cells, marked *C. E.* in the drawings on Plate xx, begins along the outer margin of the groove. In a specimen of *V. fasciatus* the cells of the groove (Pl. xx, fig. 7) were not so columnar, and resembled those of the mantle surface. The same was the case with *Tulotoma magnifica* (Pl. xx, fig. 17), but the material of this species was not sufficiently well preserved for critical work; in the embryonic mantle of this species the cells are more elongate (Pl. xx, fig. 16). In *V. delavayana* (Pl. xx, fig. 8, Pl. xxiii, fig. 3), *Taia intha* (Pl. xx, fig. 14, Pl. xxiii, fig. 3), *Margarya melanoides* (Pl. xx, fig. 15, Pl. xxiii, fig. 6) and other forms the cells lining the groove are not very different from those in *V. viviparus*.

The cells of the groove described above secrete the periostracum in the Viviparidae, and there are no other periostracal glands of the type described by Annandale (1).

Marginal Processes.—In embryos of *V. fasciatus*, as seen in the microphotographs (Pl. xxii, figs. 1, 2, *G. M. P.*), and as was confirmed by examination of various series of sections, the processes are projections of the mantle margin, and their grooves are only extensions of the supramarginal groove. The cells lining the grooves are intermediate in character between those of the supramarginal groove and the free edge of the mantle. They are narrower and not so deep as the cells of the groove, their nucleus is comparatively smaller and more rounded, while the protoplasm is not so rich in granules. None of them, like the cells of the supramarginal groove, are ciliated. They probably secrete mucus, but in view of the scarcity of granules in them, I am of opinion that the cells of the grooves do not take any part in the formation of the periostracum of the shells. In half-grown individuals of *V. bengalensis*, in which the marginal processes were still present, it was found that in sections parallel to the mantle margin (Pl. xx, fig. 4) the grooves of the processes differ in depth according as they belong to the primary, secondary or tertiary series of processes. The grooves are lined by epithelial cells, which are columnar but less deep than those of the mantle, and differ in having no flask-shaped unicellular glands between them. The structure of the processes of various members of *Dactylochlamys* and other forms, in which only the grooves of the processes are found in the adults, was found to be identical with that of *V. bengalensis*.

Supramarginal Ridge.—In young embryos of *V. viviparus*, such as that figured on Pl. xx, fig. 2, it is clearly seen that the cells of the supramarginal ridge are only slightly modified epithelial cells. They increase gradually in size from the outer to the inner margin, and are the largest about the middle of the area, where they extend deepest into the connective tissue. Further from this area they again become smaller and gradually pass into the cells which form the outer covering of the mantle. In older embryos of *V. fasciatus* (Pl. xx, fig. 6), the cells on the right are the least modified, while those on the left are much deeper and resemble the less modified cells of the adult. Most of them are arranged in separate bundles, and the cells are curved in their lower halves; as a result different sections show different parts, but in continuous series of sections it is possible to follow the cells throughout their entire extent. A slightly more advanced stage is reproduced as figure 2 (Pl. xxii), the gland cells are much deeper, and owing to lack of space are pushed sideways into the connective tissue. The supramarginal ridge does not occupy as much space on the surface as it does in the earlier stages. The embryonic mantle of *Tulotoma magnifica* (Pl. xx, fig. 16) represents a less advanced stage than that of *V. fasciatus* referred to above, while that of *D. oxytropis* (Pl. xx, fig. 9) is of about the same age.

From the above series it is clear that the gland cells of the supramarginal ridge are the highly modified cells of the epithelial covering of the mantle, and that in the earlier stages they differ only slightly from the cells which line the adjacent areas. Later they become greatly modified, but even in adults there is a continuous modification of the adjacent cells to replace those which degenerate. This is clearly shown in Herl's figure (71), and in the adult of *V. fasciatus* (Pl. xxii, fig. 5), in which the area marked X does not represent the supramarginal groove but some of the cells of the supramarginal ridge which are not fully modified.

The general arrangement of the structures in the mantle margin of the adult is shown in fig. 4 (Pl. xxii). The supramarginal groove (*S. G.*) is a shallow canal a little way from the

edge on the dorsal surface, while next to it is the area marked *X* in the figure, shown more highly magnified in fig. 5. The supramarginal ridge (*S. R.*) lies next to the groove as a raised area, and the glandular cells (*G. C.*) forming it are seen as the darker mass in the upper part of the section. Examined with a higher power of the microscope the dark mass is seen to be formed of cells, which are somewhat flask-shaped and are 270-280 μ in length. They do not lie quite straight, but as was well expressed by Herfs (71) the principle of the economy of space results in the cells becoming crowded together and curving sideways in the subjacent connective tissue. The inner ends of the cells are somewhat swollen, but the outlines are often irregular. The lower swollen part of the cells contains a rounded to ovoidal nucleus which is about 15 μ in maximum diameter. As is seen in the figures (Pl. xx, fig. 5 and Pl. xxii, figs. 6, 7) the nucleus has a prominent central nucleolus and a large number of chromatin granules scattered round it. The protoplasm is granular and somewhat vacuolated; it stains deeply with plasmatic stains like eosin, and with specific mucin stains like Methylene Blue, Mucicarmine, Thionin and Toluidin Blue. There are no pigment granules in the cells, but masses of them are often found between the bases of the cells in the connective tissue. The groups of cells are sometimes separated into indefinite bundles by connective tissue and muscle fibres.

Near the bases of cells there are usually large masses of shining yellowish rounded globular structures (*G.C.* in figures on Plates xx, xxii), which are not stained with haematoxylin or plasma stains, but which, as was determined by micro-chemical reactions, are calcareous in nature. The calcareous particles, as is discussed further on (p. 291), consist of a double organic salt of calcium, and from the connective tissue probably pass into the gland cells of the supramarginal ridge. In the cells themselves they are represented by the minute granules mentioned above.

In various members of the family, as is to be seen from the figures on Plates xx, xxii and xxiii, the gland cells (*G.C.*) differ in length and thickness, but the general form is similar, and I have failed to distinguish any specific differences. The cell contents differ according to the stage of activity of the cells, and the form of the cells is correlated with it. An extensive area of undifferentiated cells is found on the two sides of the supramarginal ridge, and these cells apparently become modified and replace the cells which degenerate.

It is not possible to be definite about these gland cells of the supramarginal ridge, but I agree with the various authors mentioned already that they probably secrete the ostracal layers of the shell.

Outer Covering of the Mantle.—The general covering of the mantle on the dorsal surface consists of cylindrical or cubical cells. In the part next to the supramarginal ridge they are elongate, but gradually become shorter as the distance from the margin increases. As is to be seen in fig. 11 (Pl. xx), the cells of the region next to the supramarginal ridge are rather elongate and narrow; they have an ovoidal nucleus without any distinct nucleolus but are rich in chromatin material, and the plasma is full of minute granules (Pl. xxiii, fig. 2, *M.E.*). There are no flask-shaped unicellular gland cells, Schulze's "Becherzellen," in between the epithelial cells, and none of them are ciliated. In the regions of the pigmented bands on the mantle, the epithelial cells contain large numbers of pigment granules confined to the upper third to half of the cells.

Though I have failed to distinguish calcareous granules in these cells, I have no doubt that they are responsible for the secretion of the hypostracal layers of the shell. They show the same reactions with Thionin, Toluidin Blue and Methylene Blue as the gland cells of the supramarginal ridge, and it may be assumed by analogy that they are similarly concerned in the secretion of some layers of the shell.

The cells which cover the margin of the mantle anterior to the supramarginal groove differ from the ones described above in being ciliated, and in having large numbers of unicellular gland cells between them. They apparently play no part in the secretion of the shell.

The structure of the spiral ridges on the surface of the mantle of some of the Viviparidae, corresponding to the ridges on the shell, is of no special interest. Their outer epithelial covering does not differ from that of the rest of the mantle, while the thickened area of the ridge is filled on the inside by specially well developed connective tissue and muscle fibres in these regions.

Pigment.—In earlier stages pigment is found in the mantle of the Viviparidae in definite cells, which, following Distaso,¹ I call chromatophores. These cells are ovoidal in outline, and have a large rounded nucleus (Pl. xx, fig. 13). The plasma of the cells contains numerous minute granules of a darker colour, varying in number and quantity in the different cells. I have not been able to trace their origin in the nucleus, as Distaso was able to demonstrate in the case of *Helix* and other Gastropods, but from the comparative poverty of chromatin material in the nuclei of chromatophores with comparatively large numbers of pigment granules (see, for example, the ones in Pl. xx, fig. 13 and Pl. xxiii, fig. 10, P.C.), I am inclined to agree with Distaso as to their nuclear derivation. As has been mentioned already, pigment granules are not found in the gland cells of the supramarginal ridge, but are present in large quantities in the epithelial cells of the upper surface of the mantle; they are particularly numerous in the cells from the areas of the colour-bands. Apparently from the chromatophores the granules are passed out, and for a time lie freely in the connective tissue near the basal ends of the cells covering the upper surface of the mantle, and, as is shown in fig. 12 (Pl. xx), they eventually pass into the epithelial cells. In the cells they are later found to lie in the upper third to half of the cells.

It is not clear as to how the secretions are passed out from the different types of gland cells, but there are no definite ducts of the type suggested by Nalepa (124) and Annandale (1). The secretion of the cells must be poured out directly on the surface, but what the exact mechanism is I am unable to say.

Summary.—The mantle of the Viviparidae and the structures constituting it are all formed from the everted shell-gland of the embryo, and the various types of cells lining the supramarginal groove and the ridge result from the modification of the original undifferentiated epithelial covering of this structure. The cells which secrete the various layers of the shell are all more or less modified unicellular glands, and apparently pour out their secretion separately and directly to the outer surface of the cells. The connective tissue is not directly concerned in the secretion of the shell substance, but the calcareous

¹ Distaso, A.—*Biol. Centralbl.* XXVIII, pp. 120-129 (1908). A detailed discussion of the production of pigment in the Gastropods is included in this paper.

material in the earlier stages is stored in it, and after undergoing various modifications is passed into the variously modified unicellular gland cells (*vide infra* pp. 290, 291). The pigment is originally found in special cells—chromatophores—in the connective tissue, and following Distaso, I believe that it is derived from the nuclear material of the cells themselves. From the chromatophores the pigment is passed into the connective tissue, and is later found in the cells which form the outer covering of the mantle.

5. HISTORICAL ACCOUNT OF THE STRUCTURE OF THE SHELL.

I. General.

The earliest work on the structure of the shell to be considered is that of Bournon (13). He regarded the shell as resulting from the crystallization of calcium carbonate and corresponding in shape with the surface of the animal over which it is formed. According to Bournon the shell consists of two parts, an outer organic covering and an inner calcareous region consisting of three zones of thin plates. The plates in turn are formed of rhombic crystals. The disposition of the plates in the outer zone is different from that in the two lower zones, and the appearance differs according as the plates are viewed from the side or the surface.

Gray (64) distinguished two kinds of shells, one in which the calcareous particles are crystallized and the other in which they are granular, and he considered these to correspond to Hachett's (67) porcellaneous and nacreous types. In the crystalline shells he described three layers of calcareous matter consisting of thin lamellae arranged one over the other and formed of narrow, rhombic crystals. In the alternate lamellae the lines of cleavage of the crystals were observed to follow the same direction, while in succeeding lamellae they cross each other at right angles. The lamellae of the middle layer are described as running at right angles to the lines of growth of the shell, while those of the outer and inner layers cross those of the middle layer at right angles and run more or less in line with an axis drawn from the apex to the mouth of the shell. The granular shells in which the structure was found to be more or less uniform were stated to consist of numerous rather thin laminae with a number of thin plates of animal matter lying between the various plates. The shells in the various Molluscs may have either a crystalline or a granular structure, but in most of the crystalline shells the inner and anterior part of the shell is covered with a laminar granular layer.

Bowerbank (18) and Carpenter (25) considered the shell to be cellular in structure and to originate from a cellular basis. Bowerbank found that the calcareous parts of the shell consisted of three strata "uniform in the nature of their structure, but alternating in the mode of their disposition. Each stratum is formed of innumerable plates, composed of elongated, prismatic, cellular structure; each plate consisting of a single series of cells parallel to each other." The plates are described as disposed alternately so that some of them are parallel to the lines of growth of the shell, while others are at right angles to them. In *Cypraea*, *Cassis*, *Ampullaria* and *Buliminus* the plates of the outer and inner strata were found to be arranged parallel to the lines of growth while those of the middle layer were at right angles to them; in *Conus*, *Pyruia*, *Oliva* and *Voluta* the arrangement

was the reverse. The prismatic cells of the various plates are described as intersecting those of the neighbouring plates at right angles. Carpenter fully agreed with Bowerbank regarding the minute structure of Gastropod shells.

Rose (142), as a result of his studies of sections of shells, came to the conclusion that the general arrangement of the layers is more or less similar in various Gastropods. He distinguished three calcareous layers in the shell, which consist of similar elements disposed in different directions. In each layer he distinguished thin, calcareous leaflets (Blättchen) which are arranged along their narrow margins and lie in the same directions in the outer and inner layers but are at right angles to those of the central layer. The leaflets, he stated, were formed of thin prisms arranged parallel to one another along their lateral surfaces. In two successive layers the directions of the prisms are at right angles to one another. He also published an ideal section illustrating his scheme of the structure of the Gastropod shell.

In the shells of *Neritina fluviatilis*, Claparède (27) designated the outer periostracum of the shell as the "Oberhaut," and described its cellular constitution in which, however, he was not able to discover any nuclei. The calcareous part of the shell he divided into two zones, an outer pigmented and an inner colourless. He did not describe the minute structure of the zones.

Leydig (103) distinguished three layers in the shell, (1) a homogeneous cuticle, (2) a calcareous crystalline layer, and (3) a homogeneous membranous calcareous layer. Longe & Mer (107) similarly distinguished three zones and added that the first calcareous pigmented zone consists of more or less vertical prisms, while the second zone is of many layers with the prisms of each layer arranged horizontally and at right angles to those of the upper zone.

Nathusius-Königsborn (125) concluded that the shell is an independent living structure which grows and develops without any relation to the animal. This part of his work has been severely criticised by Ehrenbaum (42) and Stempell (162), and need not be discussed here. His account of the structure of the Gastropod shell is useful and I include here an abstract of his summary. The structure of the shell is fibrillar, the fibrils being united to form plates which are arranged at right angles to the surface of the shell. The axes of the fibrils lie at angles of 45° to the shell surface, but in successive plates they lie in opposite directions and cross each other. The disposition of the plates is different, and those of the upper and lower zones lie at right angles to each other.

Tullberg (169) described the structure of the shell of *Buccinum* in detail and added a few comparative notes on the shells of *Strombus* and *Trochus*. He distinguished the organic cuticular covering of the shell or the periostracum, and in the calcareous part found three to four layers. In the various calcareous layers he described the arrangement of column-like structures and added that the disposition of the columns changes according as the sections of the shells are taken parallel to the margin of the aperture or at right angles to it. As to the constituents of the layers he agreed with Rose that they are formed of long, narrow plates or prisms arranged in rows. In two successive rows the prisms lie at right angles to each other. Dakin (32), following Tullberg, distinguished four calcareous layers under the periostracum. He stated that the shell may be divided into "two layers, an

outer and an inner, the latter with three subsidiary strata built up in the same way, but as the geologists say, unconformable." The outer layer he distinguished as having more organic substance than the other layers and consisting of irregular crystals. He described the other layers as being built up of plates which present different views according to the planes in which they are cut in the sections.

Nalepa (123) described in the shell of *Zonites* an outer deep brown cuticle which is the only pigmented area in the shell, the calcareous layers underneath being quite colourless. In the calcareous layers he distinguished an outer prismatic layer and a lamellar zone consisting of many layers. He did not describe the finer constituents of the various layers.

Garnault (60) considered the shell of *Cyclostoma* to be composed of calcium carbonate and to consist of three calcareous zones, an external pigmented zone of many successive layers, a middle crystalline zone and the innermost stratified zone similar to the outermost part of the shell under the periostracum. The minute structure of the various layers was not described.

In *Amphidromus Jacobi* (79) described three zones in the calcareous part of the shell. The outer and the inner layers are similar and consist of oblique stripes crossing each other, while the middle layer is prismatic.

Thiele (167) discussed the structure of the shells of Chitons in detail and referred to the structures in other molluscs. For all classes of molluscs he distinguished in the shell three layers, an outer cuticular periostracum, the outer calcareous layer or ostracum and the inner calcareous layer or hypostracum. The periostracum he considered to be the basis for the crystallization of the calcareous part of the shell, and referred to the varying development of the other two calcareous layers in the different species. Simroth (159) accepted this division even though he did not agree with Thiele in regard to the areas of the animal which secrete the various layers. In most of the recent works authors have attempted to define the regions of the shell according to this division.

Linden (105) designated the three layers in the shell as cuticle, the prismatic calcareous layer and the porcellaneous calcareous layer or hypostracum, but did not give a detailed description.

In *Trochus Robert* (140), following Thiele, distinguished the periostracum, the ostracum consisting of an outer pigmented porcellaneous zone and an inner lamellar mother-of-pearl zone, and the hypostracum. Frank (57), who investigated the shells of a number of Trochidae, found that the hypostracum is not always present, and that it is possible to distinguish three separate strata in the ostracum.

Biedermann (6) studied the structure of the shells of molluscs in great detail and to him we owe a really clear account of the highly complicated structure of the shell. He concluded that, leaving aside the periostracum, the shells of all Gastropods, whether land, freshwater or marine forms, have a "leaf-like (blätterige) or lamellar structure, which results from the shell in its entire thickness consisting of many systems of thin calcareous plates disposed one over the other like the leaves of a book; in all layers the plates lie along their narrow edges and as a result their surfaces are always at right angles to the shell surface. In adjacent plates the long axes of the plates are at right angles to one another, and in no case is the surface of any plate flush with the surface of the shell. Each plate in its turn is

formed of a very large number of thin calcareous threads whose axes cross at right angles in adjacent threads." In *Helix*, however, he had distinguished an outer calcareous zone with the appearance of a stalactite structure, but he believed that these stalactites in view of their appearance and their polarising properties are also constituted of fibres similar to those of the lamellae of the inner zone.

Flössner (51) published a very detailed and well illustrated account of the structure of the shell of *Helix pomatia*, which included instructive ideal sections of the scheme of formation of Gastropod shells in general.

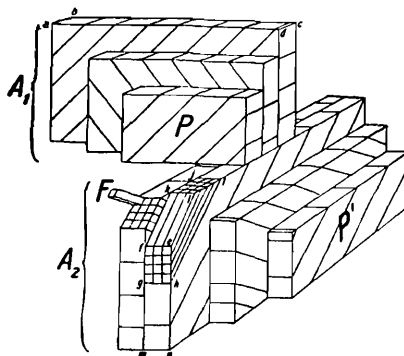

Text-fig. 1.—Scheme to illustrate the principle of the formation of the structure of the Gastropod shell. A_1 , A_2 , two layers lying one above the other, and formed of plates P, P; e, f, g, h, i, k, l, bundles formed of smaller bundles or fibrillae labelled F. After Flössner (51).

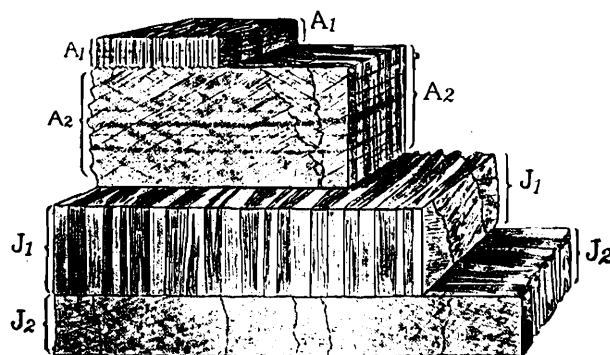

Text-fig. 2.—Ideal section of the shell from the bodywhorl of *Helix pomatia* reconstructed by Flössner (51). A_1 , A_2 , First and second outer layers, J_1 , J_2 , First and second inner layers.

He confirmed Biedermann's work, and showed that the so-called stalactite layer in the shell of *Helix* is constituted similarly to the inner lamellar layer, and that there is no difference whatsoever between the common snail and the marine mollusc regarding this zone of the shell. He divides the calcareous shell into two zones owing to the plates of the two strata running at right angles to each other. Each of the two zones is again divisible into two regions and the plates forming these also run at right angles to each other. The plates which constitute the layers in the various zones are formed in their turn of very fine fibrillae. He added that there are no true prismatic structures in any Gastropod shell and that the so-called prisms of the earlier authors are only the fibrillae united in bundles. The angle between the adjacent fibrillae is much less than a right angle.

Schumann (151) for the shells of *Gadinia*, Kleinstuber (85) for *Trochita* and *Janacus*, Beck (5) for *Buliminus*, Eckhardt (41) for *Vitrina* and Wille (174) for *Stenogyra* have des-

cribed the three layers in the sense of Thiele, but their accounts are not of sufficient importance to be reviewed in detail.

Hammersten and Runnström (68) in their paper on the embryology of *Acanthochiton discrepans* describe in detail the development and structure of this mollusc and include interesting remarks about the homologies of the areas which secrete the various shell layers in the chitons with those of the Gastropods and Pelecypods.

II. Shell Sculpture.

Bournon (13), from his studies of the shell structure of *Strombus gigas* and *Cassis cornuta*, believed that the tubercles on the surface of these shells represent hollow protuberances of the embryonic shell produced by special processes of the animal over which the first shell was modelled. Later the processes of the animal were withdrawn and the hollow regions of the shell filled up by calcareous matter.

Bouchard-Chantereaux (12) and Moquin-Tandon (118, 119) definitely ascribed the secretion of the periostracal hairs on the embryonic shells of *Viviparus viviparus* to the three finger-like processes of the mantle margin on its right side. In view of the observations of these authors that with the disappearance of the processes the three carinae or the ridges of the shell also disappear, it may be inferred that the formation of the carinae was also considered by them as being dependent on the mantle processes. Leydig (102), independently of the work of Bouchard-Chantereaux, discovered and described the three mantle processes in *V. viviparus* and connected them with the secretion of the shell and in particular with the three rows of periostracal hairs on the embryonic shell. Leydig is not quite definite as to whether in the region of the hairs the shell is secreted separately or the basal parts of the hairs form the shell, but in view of his criticism of Siebold (155), who considered the processes to be the projections of the "epidermal covering" of the embryonic shell, and his comparing them to the hollow processes which are found on the outer lip of the mouth of shells of *Strombus*, *Pterocera* and *Murex*, it may be inferred that Leydig regarded the hairs as projections of the shell itself. Leydig further suggested that the nature of the shell sculpture is indicated in the form of the shell-secreting zone of the mantle margin, or in other words the protuberances on the outer surfaces of the shells result from corresponding processes of the mantle. This was also well expressed in a general way for shells of all molluscs by Johnston (82), according to whom "the shell of every class is moulded on the mantle of the animal," and further "whenever the edge of the mantle is furnished with any fold or protuberance, with processes or beards, corresponding processes on the shell declare the fact; and these processes are cast in the form of cases for the protection of the fleshy part they represent." This was to some extent elaborated by Bronn (20), who considered the shell to be a more or less exact reproduction of the form and structure of the mantle, as a result of the later deposition of shell substance on the inside the uneven inner surface becomes smooth but the sculpture persists on the outside of the shell. As an elaboration of this view von Martens (111) stated that the transverse or vertical ridges on the surface of the shells are produced by periodic secretion of shell substance by the entire mantle margin, while the longitudinal ribs result from regular continuous secretion of definite points only. The sculpture may, purely physiologically, be pre-indicated (präformiert) in the mantle margin.

Gräfin von Linden (105) found that in *Trochus turbinatus*, *Murex trunculus* and to a limited extent in *Helix pomatia* the situation and arrangement of the mantle furrows corresponds exactly with the sculpture on the shells. She stated that it was possible to correlate all protuberances on the shells with increased secretion of calcareous substance at corresponding points on the upper surface of the mantle. In these areas, as a result of the ridges and furrows on the mantle surface, the shell-secreting areas are correspondingly increased, and Linden, who did not distinguish any definite shell-glands, added that the height of the mantle epithelium corresponds directly to the thickness of the shell over it. The tubercles or spines on the surface of the shell were also supposed by Linden to be due to correspondingly arranged areas of the mantle epithelium.

Simroth (157), from his studies of the Gastropods of the Plankton Expedition, concluded that the first foundation of the larval shell or the Prosopoconcha is a structureless, membranous covering of conchiolin, which is later strengthened by the deposit of shell-substance and develops hairs, ridges, etc. Hairs or chaetae, with which he also included comparatively feebly developed tubercles of conchiolin, are the first to appear. These result from indefinite irregularities of certain cells of the mantle margin which secrete the cuticle more actively than others. The tubercles at this stage are irregularly distributed over the surface of the shell. In the following stages the changes in the structure of the shell are due to mechanical influences (mechanischen Forderung) as a result of which the actively secreting cells become arranged at definite intervals, and the tubercles resulting from their secretions are also formed in definite rows or spirals. Larger secretions of closely grouped cells accumulate and are deposited on the surface of the shells as chaetae, while secretions from definite areas, which do not increase the thickness of the shell-membrane as a whole, form folded, wavy, longitudinal ridges. The regular wavy projections of the ridges form the bases for the protuberances, knobs and other processes which may be later developed. All these different types of protuberances on the surface of the shells are, according to Simroth, direct products of the mantle, but he does not distinguish any special areas which lead to their formation. In a later work Simroth (158) stated that the protuberances of the Gastropod shell are a result of mechanical influences, and are arranged in spirals at right angles to the mantle margin, while on the Pelecypod shell they are arranged parallel to the edge of the mantle ; in the latter case they are not due to mechanical influences but result from rhythmic secretions of the shell.

Stempell (162) did not deal in detail with the sculpture of the Gastropod shell. He, however, considered the formation of the sculpture as being connected with permanently formed structures of the mantle margin rather than with special processes which are developed afresh at regular intervals for the secretion of each tubercle.

From the results of experiments on the regeneration of the shell of Helicids by Techow (166) and a general summary of his work by Korschelt (87), it is clear that the regenerated shell in the regions away from the influence of the mantle margin is quite different in structure from the normal shell. The yellowish grey pigment of the normal shell is replaced by a whitish grey pigment, and in place of the characteristic low ridges on the outer surface of the normal shell only a fine granulation is to be seen. The structure of the regenerated peristome or of other areas of the shell where the margin of the mantle can take part in its

regeneration is the same as the normally secreted shell. It is clear from these observations that the margin of the mantle is responsible for the production of the shell sculpture.

Biedermann (7) was of opinion that the formation of the sculpture of the molluscan shells is probably connected with the structure of the mantle margin through the epithelium on its surface, which at least for a time is directly in contact with the outermost shell layers.

Annandale (1) studied the sculpture and its origin in the Viviparidae in great detail. He found that the sculpture of the shells is partly periostracal and partly impressed on the outer calcareous layers; this latter he called "test-sculpture." In the embryonic shell both types of sculpture are present, but the periostracal sculpture is comparatively more predominant. The periostracal sculpture of the embryonic shell, he stated, is not secreted but moulded by the marginal processes of the mantle. The primary spiral rows of chaetae on the shell are thus formed by the three primary mantle processes, while other rows of chaetae result from secondary processes. The fine vertical lines of the shell are due to deposition of horny matter direct from the supra-marginal groove on the shell surface, and he considered each line to be "a separate act of secretion." The underlying test-sculpture corresponds with the periostracal which is considered to be a mould for it. The uninterrupted hollow ridges on the surfaces of the shells of certain species are explained as being due to "greatly hypertrophied marginal processes, the mere presence of which on the internal surface of the shell while the calcareous matter was soft is sufficient to account for their presence." The solid continuous ridges are similarly believed to result from slight hypertrophy of the calcareous glands in corresponding areas of the mantle. In the case of more highly sculptured types of shells "the projections are formed owing to periodical hypertrophy of the calciferous glands in the part of the mantle that lies immediately beneath the ridge on the shell, and moulded into shape by temporary lobes of the mantle edge." Annandale in a second paper (2) slightly modified his earlier views. The marginal processes, he stated, correspond in position to the spiral ridges of the shells but are "far too small to mould them," and only represent points "at which the products of secretion of the calciferous cells are liable to accumulate." In the highly sculptured *Taia intha* he observed in the living animals opposite the ridges of the shell "broad, shallow almost semicircular projections on the edge of the mantle with a marginal process on the tip of each. These projections are in no way differentiated in structure from the remainder of the mantle edge and are not at all thickened in their natural state; they merely represent an increased area of secreting surface. In their natural condition and when in a state of active secretion, however, they become periodically convex above and concave below, thus forming a mould for the nodules or scales." The rows of tubercles are explained as being due to more or less rhythmic prolongations of the processes for the secretion of the projections. The smooth ridges of the shells result from continuous secretions of corresponding processes of the mantle throughout the period of growth, while in smooth shells the mantle edge is evenly convex and its secretions also regular all over. Annandale's views are essentially similar to those of Bournon, von Martens and Simroth, but in addition to attributing shell secretion to glands distributed over special areas he attached greater weight to the mechanical influence of specially developed regions of the mantle margin in moulding the different types of sculpture.

6. STRUCTURE OF THE SHELL OF THE VIVIPARIDAE.

The shell of the Viviparidae, as indeed of all Gastropods, is divisible into two constituent parts, an outer membranous organic periostracum and the thick inner calcareous layers, which are distinguished into two zones according to the arrangement of the plates constituting them and the different regions of the mantle by which they are secreted.

In this section of the paper I will deal with the structure of the shell as it is seen in sections ; the constitution of the shell, the reactions of the various substances forming it and the secretion of the different layers will be discussed separately below.

Periostracum.—The periostracum of the young embryonic shell soon after its secretion consists almost entirely of organic material, and is thin and membranous. Examined under a fairly high magnification (Pl. xxiii, fig. 7) it is seen to be formed of more or less parallel bands separated from one another by slightly rugose lines, which mark the areas of junctions of the bands and, apparently, correspond to the separate acts of secretion of the periostracal substance. Each band in its turn is seen to consist of a large number of elongated somewhat curved blocks arranged almost parallel to one another. The longer axes of the blocks run roughly at right angles to the long axes of the bands and to the margin of the aperture, while the bands themselves lie parallel to it. The periostracum of adult shells, examined after the removal of the calcareous layers, either by peeling or by the action of dilute acids, appears as a more or less homogeneous membrane, and does not show any traces of either the bands or the blocks mentioned above. In external surface view or seen as a transparent object, the periostracum exhibits faint marks of the lines of growth, while on the inner surface the impressions of the calcareous plates in the form of wavy lines arranged in a sort of network can be distinguished. In sections of the periostracum prepared after decalcification of the shell or even those prepared by grinding the shells, I have failed to distinguish any definite layers in it corresponding to those mentioned by Flössner (51) for the shells of *Helix*. The outer regions are somewhat darker and brownish, while the inner are lighter and more yellowish, but this is probably due to the outer surface being exposed to the action of light, water, etc., and does not seem to be correlated with the different times of the secretion. With age and gradual drying, as probably also through the action of the atmosphere and water in which the aquatic snails live, the periostracum becomes a more or less homogeneous membrane, and the various elements forming it at the time of its secretion become intimately fused with one another, while by stretching over the calcareous layers and by rubbing against other objects the lines of demarcation between the constituent elements disappear. Beyond the yellowish or brownish pigment, which is inherent in the periostracum, no other pigment is present in it. The ground colour of the shells is due to the colour of the periostracum, but the prominent colour bands of the shells of some of the members of the Viviparidae lie deeper in the calcareous layers, and are seen through the semi-transparent periostracum.

Calcareous Layers.—In the large number of species of the family, the shells of which I have investigated, I have been able to find only two main zones of the calcareous layers. The two layers correspond to the outer and inner layers of Biedermann (6) and Flössner (51). In the shells of the Viviparidae, however, I have failed to find any division of each of these two zones into an outer and inner region, distinguished by the arrangement of the

plates constituting them, such as is so well shown in Flössner's figures and described in his excellent account of the shell of *Helix*. In the Viviparidae it may therefore be concluded that there are only two main zones in the calcareous part of the shell, and these, following Thiele (167), I distinguish as the ostracum and the hypostracum. The two zones are both formed of a large number of elements which, following Flössner, I call plates; they are arranged in various layers like the leaves of a book. These main plates of the ostracum and the hypostracum lie at right angles to each other, those of the ostracum running in the direction of the windings of the shell or at right angles to the margin of the aperture, while the hypostracal plates run parallel to the latter. The plates are formed of large numbers of bundles of fibrils, which lie at an angle to the main axes of the plates, and in adjacent bundles cross each other at right angles. The final elements in the structure of the shells, which can only be distinguished under high magnifications, are called the fibrils. They are arranged parallel to each other and unite to form the bundles; they apparently represent the minute elements which are formed by the solidifying of the calcareous secretions of the gland cells of the supramarginal ridge and the general mantle epithelium.

Ostracum.—Seen in a surface view, the ostracum (Pl. xxiv, fig. 8, *O*.) appears like a meshwork, the plates constituting it appear alternately light and dark, and run more or less parallel to each other, and, as has been noted above, at right angles to the margin of the aperture. The various plates are not absolutely straight, and differ in thickness in various parts of their course. They often branch at the two ends, and their forked ends unite with those of the neighbouring plates. Lateral branches running in the direction of the long axes of the plates are also given off, and these connect the various plates in the same way as the branches at the ends. The alternating light and dark appearance of the plates under the microscope appears to be due to the plates lying at different levels, and is probably to be correlated with the different times at which the secretions have become set. The appearance resembles the figures of the outer layers of the shells of *Helix* in Biedermann's and Flössner's papers.

Hypostracum.—The appearance of the hypostracum in a surface view is quite different from that of the ostracum. The plates, as seen in the microphotograph (Pl. xxiv, fig. 9, *H*), are almost uniform in thickness, do not branch to any extent, and are arranged with great regularity. They run parallel to one another, and at right angles to those of the ostracal plates, and show the same light and dark arrangement. This appearance is very different from that of the inner layer of *Helix* figured by Flössner, but apparently the difference is one of degree rather than of the type of arrangement.

Having dealt in general with the structure of the shell of the Viviparidae, I will now describe the sections of those shells which exhibit special features. As a general point, however, it may be noted that the appearance of the layers of plates varies according to the direction in which the sections are prepared. In sections of the shell taken parallel to the margin of the aperture, *i.e.*, parallel to the lines of growth of the shell, the ostracal plates, which are cut at an angle, appear as a series of lines crossing one another almost at right angles, while each of the plates forms an acute angle with the surface of the shell. The hypostracal plates on the other hand are cut more or less parallel to their lateral margins, and in the sections appear as vertical columns arranged more or less parallel to one another

and with their axes at right angles to the shell surface. In a section taken at right angles to the one described above, the axes, along which the plates are cut in the two zones, are reversed, and the section presents an almost reversed arrangement of the plates of the ostracum and the hypostracum to that in a section parallel to the margin. The condition described above is quite the opposite to that figured and described by Flössner for the shells of *Helix*, but as will be clear from the microphotographs accompanying this paper (Plates xxiii, xxiv) this is the arrangement seen in the shells of the Viviparidae, and I am unable to account for the discrepancy in the two accounts.

In the following description I will deal only with the structure of the shells as they are seen with low magnifications, not exceeding 200 diameters, as the finer elements or the fibrillae composing the plates are identical in all cases, and I have nothing to add about their structure in the family. In the account I use the words *margin* and *surface* for the margin of the aperture and the external surface of the shell respectively.

The structure of (1) the more or less smooth-shelled forms like *Viviparus* and *Cipangopaludina*, (2) the solid ridged species of *Viviparus* like *V. boettgeri* Kobelt, (3) the hollow-ridged species of *Dactylochlamys*, (4) the semi-sculptured forms like *Neothauma* and *Rivularia* on the one hand and (5) the tuberculated types like *Taia*, *Margarya* and *Tulo'oma* on the other, are all separately dealt with.

Smooth-shelled Forms.—Of this type I have investigated the shells of *Viviparus viviparus* (Linn.), *V. bengalensis* (Lam.), *Cipangopaludina lecythis* (Benson) and *C. chinensis* (Gray). The structure is uniform in all the species, and it is only necessary to describe one case in detail. The periostracum during the preparation of the sections often peels off and is very seldom left intact. In a section of the shell of *C. lecythis* (Pl. xxiii, fig. 12 *P*) it is seen to consist of a rather narrow band of darkish colour overlying the calcareous zones.

The relative thickness of ostracum and hypostracum is usually maintained in the same species, but varies in different regions of the same shell so that in sections of shells taken in different directions the thickness appears to vary greatly.

The ostracal plates in a section parallel to the margin (Pl. xxiii, figs. 10, 12) are seen to run almost parallel to one another and at acute angles to the surface. The plates of the different layers, which lie one above the other, cross one another at right angles; this is well seen in the middle of the field in the photograph of the shell of *C. lecythis* (Pl. xxiii, fig. 12). In some places the plates fork at their lower ends over the hypostracal plates, and become intertwined with the plates of the latter zone. In sections at right angles to the margin (Pl. xxiii, figs. 11, 13), the cut surfaces of the bundles constituting the plates are arranged in almost vertical pillars, which in photographs and under the microscope appear alternately light and dark. In the pillars which appear as dark bands, the bundles of fibrils run from above downwards and at acute angles to the surface. In the light bands, on the other hand, the bundles lie flat one over the other and almost parallel to the surface.

The plates of the hypostracum are arranged similarly to those of the ostracum, but the direction of their axes differs from that of the ostracal plates. As a result, in sections parallel to the margin (Pl. xxiii, figs. 10, 12), the cut ends of the plates appear as vertical pillars, while in sections at right angles to the margin they run (Pl. xxiii, figs. 11, 13) parallel to one

another, and cross those of the adjacent plates at right angles. This is well seen in fig. 11, in which, as a result of unequal etching, series of plates of the various layers are seen to run in opposite directions and cross each other at right angles. The same figure also shows the parallel arrangement of the ostracal plates and the way in which their lower ends become intertwined between the forked ends of the hypostracal plates.

Solid ridged Forms.—From amongst species of this type I prepared sections of the shells of *V boettgeri* Kobelt; the section parallel to the margin passed through a number of the ridges, while the one at right angles was taken through one of the grooves. The arrangement of the plates and the bundles in the plates of both the ostracum and the hypostracum in this species is similar to that of the smooth-shelled forms described above. The interesting point about this form is the almost straight surface of the shell below the ridge (Pl. xxiv, fig. 1), there being no trace of any groove on the inner surface corresponding to the outer ridge. The ostracum as compared to the hypostracum is very thick, but in the region of the groove (Pl. xxiv, fig. 2) the difference in the respective thickness of the two zones is not so marked.

Hollow-ridged Forms.—Of this type I have investigated the shells of *Dactylochlamys oxytropis* (Benson), *D. lanaonis* (Bartsch) and *D. persculptus* (P. & F. Sarasin); in the last species the shell is very thick, and appears to be covered with almost solid ridges. The sections parallel to the margin were all taken through the ridges while those at right angles were mostly through the intermediate areas. The periostracum in these forms is specially well developed, and is very closely applied to the ostracum lying below it. I have examined various preparations of it made from adult shells, but have not been able to distinguish any structure in them. In the region of the ridges on the shell the periostracum follows the outline of the ridge in the sections, and plays an important part in the formation of the ridges (*vide infra* pp. 293-297).

In sections of the shell parallel to the margin, the inner outline of the sections of the grooves is concave, but the concavity varies in different species. It is most marked in *D. oxytropis* (Pl. xxiii, fig. 14), while in *D. lanaonis* (Pl. xxiii, fig. 16) and *D. persculptus* (Pl. xxiv, fig. 5) it is less pronounced. In all these cases the concavity is reduced by the extra hypostracal plates which fill up the hollow grooves on the inner surface. The structure in all the three species investigated is uniform, and I will include only short notes on the sections, which are reproduced in the plates accompanying this paper.

In sections parallel to the margin the ostracum is seen to be very well developed in the region of the ridges. The plates of this zone, as in a section of *D. persculptus* (Pl. xxiv, fig. 5), run crosswise from side to side and almost parallel to the surface. About the middle of the ridge, or the groove as it should be termed when viewed from the inner surface of the shell, the plates curve upwards to fill the concavity. In sections at right angles to the margin the ostracal plates are seen to be arranged in columns, which appear alternately light and dark and, as is clearly shown in a section of the shell of *D. oxytropis* (Pl. xxiii, fig. 15), the plates often fork above and below, become connected with one another and bound up with the plates of the hypostracal layers.

The hypostracum in all the species in sections parallel to the margin is seen to be formed of vertical columns of plates. The columns are not quite vertical to the surface in the region

of the ridges, but curve outwards along the sides, and about the centre their number is greatly increased by the forking of the plates (Pl. xxiv, fig. 5). The same section shows the lines of growth of the shell in this zone as somewhat arched horizontal lines. In sections at right angles to the margin the plates and bundles forming them run at acute angles to the surface, and cross at right angles the plates of the subjacent layers (Pl. xxiii, fig. 17). In *D. persculptus* (Pl. xxiv, fig. 6) the hypostracal layers appear to be arranged in vertical columns, but this is due to the section being a little oblique. This section enables one to understand the different appearances which are produced by the plates and the bundles forming them, according to the planes along which the sections are made. The same section, as also that of *D. lanaonis* (Pl. xxiii, fig. 17), shows the basal part of the hypostracal layer as having a different arrangement from the rest; this is due to the plates being inclined at slightly different angles, and having been cut along different planes from the rest.

Semi-sculptured Forms.—Of this type I have investigated the shells of *Neothauma tanganyicense* (Smith) and *Rivularia auriculata* (von Martens) var. *bicarinata* Kobelt. In both the species sub-solid ridges are found on the shells in the regions corresponding to the sutural and the peripheral primary ridges of the embryonic shell. I figure sections of the latter. The periostracum is well developed, but does not show any special structure. The ostracum is very much thicker than the hypostracum, and shows a number of lines of growth (Pl. xxiv, fig. 3). In sections parallel to the margin the ostracal plates are arranged in vertical columns, most of which fork irregularly, send out lateral branches, and often do not extend through the entire length of the ostracal zone. In the lighter columns, which alternate with the darker ones, the bundles are arranged parallel to the surface, while those of the darker bundles are not so obliquely arranged. In a section at right angles to the margin and passing through the peripheral ridge, the different parts of the ridge are seen to be unequally thickened (Pl. xxiv, fig. 4). The bundles of the plates are arranged in the same way as in other members of the family. The hypostracal zone is not well shown in the section parallel to the margin (Pl. xxiv, fig. 3) and its component elements are not easy to distinguish in the photograph, but the lines of growth are seen as darker lines; these latter appear as lighter lines in sections at right angles to the margin (Pl. xxiv, fig. 4). In sections at right angles to the margin the column-like arrangement of the plates is clearly shown, and it was observed that in *Rivularia* the hypostracal plates are more closely arranged than in other members of the family.

Tuberculated Forms.—I have examined the shells of a number of species of *Taia*, *Margarya melanoides* Nevill, and *Tulotoma magnifica* (Conrad). In all these forms, whether provided with tubercles or elongated scales, the structure of the shells is similar, and it will suffice to deal with one of the forms in detail. I reproduce photographs of the ostracal and hypostracal plates magnified about 200 times as seen in sections at right angles to the margin, to show the structure of the bundles in *T. crassicallosa* Annandale & Rao. The periostracum is not seen in the photograph of a section of *Taia naticoides* (Theobald) parallel to the margin (Pl. xxiv, fig. 8). In other sections, however, it was found to form a thin membranous covering over the ostracum; its relations to the tubercles are considered separately below. The ostracum, as in *V. boettgeri* or the semi-sculptured species like *Neothauma* and *Rivularia*, is very thick and forms the greater part of the calcareous region of the shell.

The plates constituting it in the region of the ridges (Pl. xxiv, fig. 8) or the tubercles (Pl. xxiv, fig. 10), as seen in a section parallel to the margin, are arranged at acute angles to the surface and cross those of the subjacent layers at right angles. In the region of the tubercles, where the concave cavity on the inside is filled by the ostracal plates, the plates are arranged in the same way as in the hollow-ridged species described above. In sections at right angles to the margin, the plates are found to be arranged vertically in columns, which show the usual alternating dark and light appearance. The tubercles are formed entirely by the ostracal layer and a thin covering of periostracum both above and below the calcareous part (Pl. xxiv, figs. 9, 11). The section of the shell of *T. crassicallosa*, referred to above, shows two consecutive scales formed one next to the other, and illustrates the way the plates curve to fill up the hollow tubercular areas in these regions. The same section distinctly shows the lines of growth in both the ostracal and hypostracal zones.

In a more highly magnified photograph (Pl. xxiv, fig. 12) of the ostracal plates, as seen in a section at right angles to the margin, the bundles of fibrils in the darker columns are seen to run obliquely at different angles to the surface, while in the lighter ones they run more or less parallel to the surface. It also shows the forking of the plates over those of the hypostracum and the manner in which the plates of the two zones unite with one another. The plates of the hypostracum are arranged similarly to those in the shells of other members of the family, and it is only necessary to note the peculiarities of the sections figured. The shell of *Taia naticoides* cut parallel to the margin (Pl. xxiv, fig. 8) shows the plates arranged in vertical columns, while in a section at right angles to the margin (Pl. xxiv, fig. 9) the plates, which are cut a little obliquely, exhibit the forking and branching and their connection with the ostracal plates lying above them. In a more highly magnified section, examined as a transparent object, the bundles of the plates of the lower layers are seen through those of the upper layer crossing each other at right angles (Pl. xxiv, figs. 12, 13). Underneath the ridges and the tubercles the outline of the hypostracal region (Pl. xxiv, fig. 10) is somewhat concave in the same way as it is in the hollow-ridged forms.

Reference may also be made to the manner in which the succeeding whorls become connected with the previous ones. As is seen in a section of *D. persculptus* (Pl. xxiv, fig. 7) through the penultimate and a part of the bodywhorl taken parallel to the margin, the periostracum persists between the calcareous layers of the two whorls and forms the foundation on which the thick ostracal layers of the following whorl become attached uniting the two shell whorls. The plates in this region branch more extensively and are more closely placed so as to follow the outlines of the preceding whorl.

Summary.—The shells of the Viviparidae consist of an outer thin organic covering—the periostracum—and the thick inner calcareous region, which is divisible into an outer ostracum and an inner hypostracum. The periostracum of the adult shell is a homogeneous membrane, without any special structure, but that of the embryonic shell shows an almost exact reproduction of the cellular elements of the supramarginal groove by which it is secreted. In both the smooth and the sculptured types the mould for the deposits of the calcareous part of the shell is formed by the periostracal covering. For the discontinuous tubercles or the scale-like projections of the shells also the first mould is apparently formed by the

periostracum, the separate structures being due to discontinuous secretion of the periostracum and later of the calcareous layers.

The ostracum and the hypostracum in the calcareous part of the shell are identical in structure, and the different appearance of the elements in the sections is due to the different planes along which they are cut during sectioning. Each of the zones is formed of a large number of strata or layers which are arranged parallel to one another in each zone, but the layers of the ostracum lie at right angles to those of the hypostracum. Each layer in its turn is formed of numerous plates, arranged parallel to one another. The plates consist of large numbers of bundles of fibrils, which in adjacent plates run at right angles to one another. The fibrils are the final elements, which can be distinguished by means of the microscope. In smooth-shelled forms the ostracum and the hypostracum are of almost equal thickness, but in forms with sculptured shells the ostracum forms the greater part of the thickened ridges, the tubercles and the scaly projections.

7. SECRETION, COMPOSITION AND THE FORMATION OF THE SCULPTURE ON THE SHELL OF THE VIVIPARIDAE.

As a result of the work of the various authors reviewed already and my observations on the Viviparidae, there can be no doubt that the secretion of the shell is entirely due to the mantle. The periostracum and the ostracal calcareous zone is secreted by the mantle margin, while the general epithelial covering of the mantle behind the supramarginal ridge forms the hypostracal calcareous zone.

From a study of the structure of the periostracum and the contents of the modified epithelial cells of the 'gouttière palléale' Moynier de Villepoix (121) concluded that in *Helix* this area forms the periostracum. In *H. aspersa* some of the cells at the base of the pallial groove were further found to be specially modified to form a 'glande globuligène,' which was believed to be responsible for the secretion of the periostracum. Moynier de Villepoix considered the secretion of the periostracum as unique in molluscs, and described it as being of the nature of an endogenous formation. According to him a small vacuole appears in the granular protoplasm of the cells, it gradually grows at the expense of the protoplasm until it appears as a single or a number of globules, which occupy the greater part of the cell. The globules are supposed to be extruded from the cells by the bursting of the cell wall, and Moynier de Villepoix suggested that probably the muscles below the cells help in the extrusion of the granules. This gland was not found by Moynier de Villepoix in *H. hispida* in which the periostracum is specially well developed and is furnished with hairy projections, and no corresponding gland has been found in the large number of Gastropods the mantle margin of which has since been investigated. Biedermann (6) did not remark on the endogenous formation of the periostracum, but stated that it consists of polygonal structures which directly correspond to and present exact impressions of the cells by which they are secreted. The periostracum is formed by the hardening of the secretion of the cells of the supramarginal groove. Biedermann compared the periostracum to the chitinous covering of the Arthropods, and considered it to be a true cuticular formation. This view, however, it may be noted, is quite different from that of Bowerbank (18) and Carpenter (25), who considered the shell to have a cellular constitution. Annandale (1)

did not correctly identify the periostracal glands, but rightly suggested that the periostracal substance 'is poured in a liquid condition into the supramarginal groove,' and passing through the grooves of the processes is deposited on the edge of the lip of the shell.

As has been mentioned above there is no 'glande globuligène' in the Viviparidae, and I am of opinion that the periostracum in this family, as indeed in all Gastropods, is secreted in the form of a solution by the cells of the supramarginal groove. In young embryos and even later when the shell is being actively secreted, the margin of the shell is embedded in the supramarginal groove and is intimately connected with its cells. In sections of an embryo of *V. viviparus* in this condition it was found that the area of attachment consists of the undifferentiated periostracal secretion in the form of a series of elongated pillar-like masses, which lie parallel to one another, and correspond exactly both in number and arrangement to the cells of the supramarginal groove by which, apparently, they are secreted (Pl. xxiii, fig. 1, P.S.). The young periostracum of the embryonic shells, as has been described already, shows the same structure, and a similar appearance has been figured by Biedermann (6, pl. v, fig. 30) for the young shell of *Helix*. These pillar-like structures result from the hardening of the plastic secretions of the cells of the supramarginal groove, and each of them probably corresponds to a single act of secretion.

The periostracum when freshly secreted, and even for some time afterwards, is positive to the Biuret Reaction. Small pieces of it after treatment with copper sulphate solution became deep violet after washing and on being placed in a solution of sodium or potassium hydroxide. This positive reaction of the periostracum in the earlier stages, as was also found by Biedermann (6) in the case of *Helix*, shows that the substances forming it are of the nature of proteins. Later, however, the periostracum of the older shells is negative to the Biuret Reaction. The sclero-protein constituting it at this stage and resulting from slight changes in the constitution of the original proteins was given the name Conchiolin by Fremy.¹ He studied the constitution in great detail and found that Conchiolin is insoluble in water, alcohol or ether, and does not dissolve even in concentrated alkaline or acid solutions. It may, therefore, be inferred that the periostracal substance is of a protein nature. I have not studied its chemical composition, but am able to confirm Fremy's results for the periostracum of the Viviparidae.

As to the first sculpture of the shells in the form of hairs or ridges Moynier de Villepoix was right in considering it as entirely periostracal. The hairs on the shells of *Helix hispida*, as I can confirm from my own observations, are entirely periostracal structures, and the calcareous layers do not take any part in their formation as was believed by Leydig (103). In the case of the Viviparidae the embryonic sculpture whether in the form of hairs or ridges is, as Annandale (1) rightly noted, periostracal, but in the adults the ostracum fills up the grooves on the inner surfaces of the ridges, and all forms of sculpture on the adult shells are produced by both the periostracum and the calcareous layers of the shell.

The first calcareous layers of the shell were believed by Longe & Mer (107) to be already fully formed as rounded discs, and lying in the cells of the epithelial organ (=supramarginal ridge of the present account), whence they are deposited on the inner surface of the periostracum. Moynier de Villepoix (121) suggested that probably an organic substance of

¹ Fremy, E.—*Ann. Chimie e. Physique* (3) XLIII, p. 96 (1855).

an albuminous nature is secreted with the calcium in the form of calcium carbonate. The mucus-like secretion is deposited on the inner surface of the periostracum, and the further process may best be stated in the words of the author ' la cristallisation du calcaire ne serait plus qu'une question de séparation moléculaire : la dissociation du bicarbonate en dissolution dans le liquide devant forcément amener la cristallisation du carbonate en mélange avec l'albumine à l'état de calcosphérites de formes variables.' Biedermann (6) as a result of extensive experiments is of opinion that the secretion consists of a solution of calcium phosphate, most of which after crystallization is transformed into calcium carbonate. Later,¹ however, he was of opinion that there may be some calcium carbonate also mixed with the calcium phosphate, but his remark that ' die primär abgelagerte Phosphatschicht später unter dem Einfluss der lebenden Zellen wieder gelöst und mit neuem Sekret von anderer Zusammensetzung gemischt, eine zur bildung der " Stalaktiten " geeignete Lösung liefert ' is difficult to understand. Annandale (1) is not definite as to whether the secretion is in the form of a solution or solid particles.

I am inclined to agree with Biedermann and earlier authors that the calcium is taken with the food by the animal, and that from the alimentary canal it passes into the liver, as was supposed by Barfurth² and has been confirmed by Biedermann & Moritz.³ From here the calcium passes with the blood stream to various tissues as was noticed by Annandale (1), and I can confirm from my observations that this calcium, in the form of calcosphaerites, is then deposited in the connective tissue. The calcosphaerites become deeply stained with borax carmine or Delafield's haematoxylin, and disappear after being treated with dilute acids. In micro-chemical tests they were found to be positive to all reagents mentioned in Zill's work (179) for identifying calcareous particles, while the production of gas bubbles on the addition of acids shows that they consist of calcium carbonate. A certain amount of protein material is, however, mixed with them, as even after the sections are left for twenty four to forty eight hours in dilute acids a matrix remains in place of the calcosphaerites. The calcosphaerites must hereafter undergo some changes in their composition, for during the next stage in which they are found lying close to the bases of the gland cells of the supramarginal ridge, they do not show the characteristic form of the calcosphaerites, nor do they stain in the same way. They consist of small rounded or ovoid globules of a shining light yellowish colour. They are not affected by acids, but form the characteristic octahedral crystals of calcium oxalate on being treated with a solution of ammonium oxalate. I have not studied their chemical composition, but from the work of Biedermann on *Helix* it may be assumed by analogy that they are probably calcium phosphate masses with a certain amount of protein material mixed with them. The probability of their being of the nature of a double organic salt should not be ignored. The globules are then found in the gland cells of the supramarginal ridge, where they appear as minute granules in the glandular secretion.

As to the deposition of the calcareous material on the lower surface of the periostracum, Moynier de Villepoix (121), following the line suggested by Harting's⁴ experiments on the

¹ Biedermann, W.—*Zeitschr. allg. Physiol.* I, pp. 154-208, pls. iii-vi (1902).

² Barfurth, D.—*Archiv Mikrosk. Anat.* XXII, pp. 473-524, pl. xx (1883).

³ Biedermann, W. & Moritz, P.—*Archiv ges. Physiol.* LXXV, pp. 1-86, pls. i-iii, (1899).

⁴ Harting, P.—*Verhandl. kon. Akad. Wetensch. Amsterdam*, XIV, pp. 1-84, pls. i-iv (1873).

artificial production of calcosphaerites by precipitating calcium carbonate ($\text{CaCl}_2 + \text{K}_2\text{CO}_3 = \text{CaCO}_3 + 2\text{KCl}$) in a liquid containing organic substances like albumin, gelatin, etc., found that it was possible to obtain bodies similar to the calcosphaerites by mixing precipitated chalk dissolved in soda water with egg albumin. He further found that on varying the proportions of the calcareous and the albumin solutions it was possible to vary the size and numbers of the calcosphaerites. Steinmann,¹ who carried out further experiments in this direction, concluded that the deposition of the calcium is due to an extra-cellular crystallisation process, and that the most important part in this process is played by the interaction of calcium carbonate on an organic albuminous substance. This view of the explanation of the structure of the shell on purely physico-chemical lines was adopted in a slightly modified form by Simroth (159). Stempel (162) in addition to the above brought in the influence of the so-called 'Sekretionkomplexe' for explaining the formation of the structural elements of the shell. These secretion complexes, as Biedermann rightly remarked, are purely of the nature of hypotheses for which there is no support either in the structure of the soft parts or of the shell. Biedermann's account (6) is undoubtedly the clearest exposition of the present state of our knowledge of the subject, and I agree with him as to the general principles. According to him 'ohne allen Zweifel jeder durch eine besondere Struktur ausgezeichneten Schalenschicht auch eine besonders geartete, von besonderen Zellen bereitete Sekret entspricht, aus dem sich unter Bedingungen, die zur Zeit noch nicht hinlänglich klargestellt erscheinen, aber jedenfalls nichts mit einer durch Fäulnis bewirkten Eiweisszersetzung zu tun haben, jene charakteristischen Formen ausscheiden.' The only points about which I differ from him are that, as has been shown already, the structure of both the ostracal and the hypostracal zones is similar, and that the same influences are at work in the formation of the two zones; further, though the influence of the organic substances found in the mucus-like secretion is not quite as was suggested by Harting, Moynier de Villepoix, Steinmann and others, there can be no doubt that it plays an important part in the deposition of the calcareous part of the shell.

Reference may here be made to the analyses of the shells of various species of Asiatic Viviparidae by Fowler and Malandkar.² According to these authors the calcium in the shells is in the form of carbonate.

In order to decide whether the calcium carbonate in the shells of the Viviparidae is in the form of calcite or aragonite, I used the methods suggested by Schmidt.³ Powdered shells on being boiled for about half a minute in a concentrated solution of cobalt nitrate (Meign's Reaction), or on treatment with a concentrated solution of Mohr's Salt, gave different results for different species. Thick-shelled forms like *Margarya* or *Tulotoma*, which gave positive reactions, appear to consist entirely of aragonite, while in the case of the thin shelled species results were mostly negative, and apparently in these shells calcium is deposited in the form of calcite. In some cases as *Rivularia* and *Neothauma* some of the powdered part of the shell showed a positive reaction, while the rest was negative, and it appears, therefore, that in these shells the various layers are differently constituted.

¹ Steinmann, G.—*Ber. naturfor. Ges. Freiburg*, V, XI (1889, 1899). I have not been able to consult Steinmann's papers, and my remarks are based on the excellent summary of the works in Stempel (162) and Biedermann (6).

² Fowler, G. J. & Malandkar, M. A.—*Journ. Ind. Inst. Sci.* VI, p. 190 (1923).

³ Schmidt, W. J.—*Die Bausteine des Tierkörpers in Polarisirten Lichte*, pp. 67, 68 (Bonn, 1924).

Many thin sections of the shells of various Viviparidae have been examined with polarised light, but owing to the minuteness of the fibrils it was not possible to arrive at any definite results as to whether any given layer was composed of calcite or aragonite.

The secretion of the smooth or almost smooth shells with only a few very low ridges or with purely periostracal sculpture may be considered first. In these forms the embryonic shell of all the species has three low ridges ornamented with periostracal chaetae. The three rows of chaetae and the ridges correspond to the three primary marginal processes in position, and as Bouchard-Chantereaux (12), Moquin-Tandon (118, 119), Leydig (102) and Annandale (1, 2) rightly concluded, they are directly due to the marginal processes of the mantle. This was further confirmed by Annandale's observations on the presence of secondary and tertiary series of marginal processes corresponding to similar ridges on the shells of some Viviparidae. My examination of the soft-parts of the adults and embryos of large numbers of forms of the family fully confirms the views of the earlier authors, and I am of opinion that, in the smooth-shelled species, the periostracal chaetae found on the shells of various species and the low ostracal ridges on which the chaetae are found are directly due to the influence of the marginal processes. In some species the processes still exist, but there are no corresponding ridges, as for example in *V bengalensis* and still more so in *V dissimilis*, but the processes are greatly reduced, and the only possible explanation seems to be their degeneration.

In the secretion of the shell the periostracal secretion is deposited along the margin of the shell from the supramarginal groove, and in the case of the marginal processes the secretion is conveyed along the grooves of the processes and is moulded over the processes themselves. Where the processes are reduced the shell area produced over them does not differ from the rest of the shell deposited by the other parts of the margin, but where the processes are well developed they form periostracal projections on the shell. The latter is the case in the embryos of almost all the species, and becomes specially important in the production of the well developed projections of different types on the adult shells of various species. The secretion of the first calcareous layers or the ostracum results from the glandular supra-marginal ridge, while the hypostracum continues to be secreted later on the inner surface of the ostracum by the general epithelial covering of the mantle and thus the shell increases in thickness.

As to the formation of the sculpture of the shells there can be no doubt that it is due to the specially developed marginal processes, which persist in the adults of various species. The opinions of the various authors like Bournon, Johnston, Bronn, Leydig, von Martens von Linden, Annandale and others have already been reviewed, and it is only necessary to refer to the suggestion of the Sarasins, a communication from whom has been included by Biedermann in his valuable work (7). These authors affirm that the processes of the mantle margin form the projections on the shell, particularly during the periods of growth. They referred to the processes on the mantle of *Physa*, which, however, they could not explain in view of the shell of this form being smooth. Similar projections are found on the mantle margin of the Melaniidae, but the processes are solid and have no mid-dorsal groove of the type found in the Viviparidae, and are certainly not correlated with the projections of the shell in the same way as those of the Viviparidae. Probably the same explanation will be found

to serve for the mantle processes of *Physa*, but at the present time I have no opportunity of confirming it.

My views on the subject of the production of the sculpture of the shells are based on the different development of the marginal processes of the mantle in the embryos of the different species of the family, and still more on the degree to which all or some of them persist in the adults. I differ from the previous observers in attaching special importance to the marginal processes in connection with the deposition and moulding of the periostracal secretions, and in this connection I consider the rôle of the grooves of the processes to be of considerable importance. The secretion in the supramarginal groove is conveyed along the grooves of the processes not only from the cells directly opposite them but also from the adjacent areas, and this large amount of secretion is moulded on the processes themselves. The secretion, as has already been noted, is purely organic in nature, and forms the periostracal covering on the inner surface of which the ostracal calcareous material is later deposited. It follows, therefore, that the calcareous projections will resemble both in form and size the periostracal moulds in which they are formed.

In forms like *Dactylochlamys*, in which the shells are provided with continuous hollow ridges, it has been observed that the marginal processes are specially developed, or as Annandale aptly stated "hypertrophied." They persist throughout life, and regulate the intermittent deposit of the periostracal secretion along the lines already laid and mould it in the form of hollow channels. The hollow ridges of the shells, as seen from the outer surface, correspond exactly in number, arrangement and position to the marginal processes and apparently the periostracal secretion conveyed by the latter through their grooves is laid along the margin of the shell in line with the already existing ridges, and moulded into form with them. In this connection the purely mechanical influence of the ridges on the mantle behind the supramarginal ridge, such as are found in *Dactylochlamys lanaonis*, *D. pagodula*, and even in forms like *Tulotoma*, *Neothauma* and others, probably both in embryos and adults can not be ignored. The epithelium on the surface of the mantle behind the supramarginal ridge secretes the hypostracum, and in these forms the spirally placed ridges of the mantle would help in keeping the ridges of the shells hollow. This mechanical influence is further demonstrated by the fact that in the earlier whorls of the shells, which are occupied by the visceral mass and where there are no ridges on the surface of the animal, the grooves gradually become shallower by being filled up with the hypostracal secretions. The same condition in a less marked degree is found in the penultimate and the first part of the bodywhorl, where the mantle ridges gradually become less prominent.

I have had no opportunity of examining the animals of the forms with semi-solid or solid continuous ridges on the shell, but the structure of the shells, as for example of *V. boettgeri* and still more of *D. persculptus*, shows that the ridges are originally hollow, and in the earlier stages appear as hollow concave channels on the inner surface of the shells. At this stage they resemble the hollow-shelled forms of the subgenus *Dactylochlamys*, and consist of the outer periostracum and the inner ostracum only. Later, as probably there are no ridges on the surface of the mantle to influence the form in which the hypostracum is deposited, the grooves are filled by an increased quantity of calcareous secretion. Various

grades ranging from almost flat to concave inner surfaces of the grooves are found in different species and even in different parts of the same shell.

In both the cases referred to above the material deposited in each period of secretion of the shell must follow the lines of the parts of the shell already formed, and during succeeding periods also must start from where it had stopped at the end of the preceding period. In this connection the marginal processes play a very important part.

The last type to be considered is that in which the shells are ornamented with separate and almost discontinuous tubercles, knobs or scale-like projections. Two points, which seem to have escaped the attention of all previous workers, must be considered first. The tubercles, of whatever form, are developed on continuous spiral ridges corresponding to the primary, secondary or tertiary ridges of the embryonic shells, and represent only specially developed areas of the ridges themselves. The sculpture of the shells, leaving aside that of the whorls corresponding to the embryonic shell, is best developed on the earlier whorls, particularly in the sculptured forms of the Viviparidae.

In the various species of the remarkable Burmese subgenus *Taia* Annandale, the tubercles on all the ridges are best marked on the penultimate whorl. All the rows of tubercles are almost equally developed, but in some cases, varying with species and age, the sculpture is almost equally developed on the whorl previous to the penultimate and on the first part of the bodywhorl. On the bodywhorl itself, however, the tubercles of the peripheral ridge alone are well developed, while those of the other primary and secondary ridges are greatly reduced, and the ridges appear to be uniformly developed.¹ In the case of *Margarya* Nevill this is still better marked. The tuberculated ridges are much better developed in the young shells and on the earlier whorls of the older shells. The bodywhorl of full grown individuals has very few tubercles and the ridges also are less strongly developed. Conditions are very similar in *Tulotoma* Haldeman, and it may, therefore, be concluded that with age the production of the sculpture becomes greatly reduced. It is clear, therefore, that the origin of the sculpture of the shell of the Viviparidae, as Annandale rightly pointed out, is to be looked for in the marginal processes of the mantle which undoubtedly become reduced with age. As with the continuous ridges on the shells, so the different types of discontinuous sculpture are due to successive intermittent secretions of uneven amounts of periostracum followed by similar and more pronounced secretions of the ostracal shell layers. The periostracal secretion conveyed through the grooves of the processes is moulded on the processes in the form of scales or tubercles, and later this is strengthened by the increased secretion of the ostracal layers by the specially developed "cushion-like thickenings" of the supramarginal ridge which are developed opposite the marginal processes of the mantle and correspond to the ridges of the shell. These thickenings were first observed by Annandale (1) in preserved material of some species of *Taia*, and later (2) their presence was confirmed by the same author from examination of living individuals of different species of the same subgenus. I have found them in preserved material of *Taia*, and similar structures are also recognizable in the mantle margin of *Tulotoma*. It is thus clear that the increased secretion of the ostracal substance in special regions combined with the intermit-

¹ For figures of the different species of *Taia* reference may be made to the excellent plates in Annandale's paper (*Rec. Ind. Mus.* XIV, pls. xv-xviii (1918)).

tent discontinuous secretion of the periostracum, which is indicated by the presence of periostracal covering on both the upper and lower surfaces of the scaly tubercles of *Taia* and *Margarya* (*antea*, p. 288) is responsible for the formation of the tubercles. Each tubercle must be completed during one period of secretion of the shell, and the shell margin starting from it, with the next period of activity, is continued originally as an ordinary ridged area, and later with specially increased secretion the next tubercle is formed in line with the previous one. In some cases (Pl. xxiv, fig. 11), owing probably to suspension of secretion during the same period of secretion, two tubercles lying one above the other may be formed.

To sum up, it may be noted that the cushion-like thickenings secrete more calcareous matter than the adjacent parts of the supramarginal ridge, and that this helps in the formation of the specially developed sculpture on the shells in the areas corresponding to the thickenings. As long as the calcareous matter is evenly secreted sculpture in the form of even ridges is formed in the already moulded periostracal structures, but with increased activity in the secretion of the ostracal zone followed by a period of relaxation, the periostracal secretion is transformed into a scaly or tubercular protuberance strengthened by the calcareous ostracal matter and greatly raised from the adjacent area of the shell. The next periostracal part of the shell starts below this protuberance instead of from its margin. As to what determines the periodic increased activity it is impossible to be certain, but there is no evidence of secretion complexes in the sense of Stempel (162).

It is not possible to offer any explanation as to why the marginal processes are better developed in the embryos of some species than in others, or why they persist in some and degenerate or altogether disappear in the adults of others. A general reduction with age is, however, indicated by the reduction of the sculpture on the older whorls of the shells, and this points to the processes being of the nature of primitive structures which persist in certain forms and lead to highly sculptured shells, while in others they disappear or become reduced, and the resulting shells are correspondingly smooth or only slightly sculptured. Annandale (2) was probably right in considering the sculpture as being due to evolution of a particular structure, in this case the marginal processes, and with it the hypertrophied region of the supramarginal ridge, and further to the inheritance of one kind of acquired character. Evolution of similar types of sculptured shells due to the similar structure of the respective animals, as I have discussed elsewhere, is, however, due to parallel evolution, and does not imply any genetic relationship between the various forms.

Annandale (1) remarked that in the shells of the Viviparidae the "colour-pattern is periostracal in origin, though the calcareous matter may be slightly stained." Flössner (51) in the case of the *Helix* shells considered the pigment to be confined to the outer calcareous zone. In order to decide this point definitely the periostracum was removed from the shells of a number of banded species of the Viviparidae, and it was found that the colour-bands, as already noted, are situated in the calcareous part. On removing the various layers of the calcareous part by gradual decalcification, it was found that the pigment is confined to the area between the ostracum and the hypostracum, and is secreted apparently with the hypostracal layers.

The development of the shell sculpture is directly associated with the grooved marginal processes of the mantle. The processes are not the organs of secretion, but act as mechanical

moulds over which the continuous ridges, whether hollow or solid, or the separate protuberances of the shell are formed ; they also act as guides for the deposition of the shell along regular lines. The sculpture of the embryonic shell is entirely periostracal, while that of the adult shell is formed by the periostracum and the ostracum ; the hypostracal layers are only secondarily concerned in it. In all cases, however, the sculpture is performed by the periostracal secretion moulded over the specially developed marginal processes.

The sculpture becomes less pronounced on the later whorls of the shells, and this is correlated with the gradual reduction and atrophy of the marginal processes of the mantle. It is not possible to determine the causes for the different development of the marginal processes both in the embryos and the adults of the various members of the family Viviparidae, but Annandale's explanation of the evolution and inheritance of certain acquired characters appears to be the most probable. Similar types of sculpture on shells of species found in widely separated areas are examples of parallel evolution and do not indicate genetic relationship between the different forms.

In addition to the inherent pigment in the periostracum the colour-bands of the shells of the Viviparidae lie in between the ostracal and the hypostracal layers.

Summary.—The periostracum is entirely organic and consists of modified sclero-proteins, which have been given the name of Conchiolin. It is secreted by the cells of the supramarginal groove in the form of a solution.

The calcareous material for the formation of the shell is probably taken in the form of carbonate with food and passes from the alimentary canal into the liver. From the liver it is carried with the blood stream, and is stored in the connective tissue of the mantle, and probably also in other areas, in the form of calcosphaerites. The chemical reactions of the calcosphaerites show that they do not consist entirely of calcium carbonate, but also have an organic matrix. The calcosphaerites later undergo some chemical change and become transformed into a double organic salt with the calcium in the form of a phosphate, and are found as shining rounded globules lying near the bases of the gland cells of the supramarginal ridge. From here they pass into the gland cells and are secreted with the mucus-like secretion of the cells. The deposition of the calcareous layers of the shell in the form of fibrillae appears to be due to the interaction of an organic albuminous substance on the calcareous material, both of which are found in the secretion of the cells, but, with our present knowledge, it is not possible to determine the influences which are at work. The calcium carbonate in the adult shells of the Viviparidae results from the transformation of the calcium phosphate material which is secreted by the gland cells. It is deposited either as calcite or aragonite, and the different layers of the shells consist of either calcite or aragonite, both of which in some form are found in the same shell. The ostracal layers of the shell are secreted by the gland cells of the supramarginal ridge, while the hypostracal part is secreted by the general epithelium which covers the outer surface of the mantle.

8. REVIEW OF THE LITERATURE ON THE EMBRYONIC SHELL-GLAND AND ASSOCIATED STRUCTURES IN MOLLUSCA.

I proposed working out the development of the embryonic shell gland the mantle and the shell-gland region of the adult of *Viviparus viviparus* (Linn.), and with this

end in view had collected and preserved embryos of various stages, and written up the following review of the literature on the subject, when I came across Andersen's paper¹ on the development of the identical areas in the same species. This masterly work together with the earlier ones of Erlanger (43) and Otto and Tönniges (126) makes it unnecessary to go over the same ground again. In view of the great importance of the embryonic shell-gland, and as no detailed summary of the previous work is available, I include here a review of the literature dealing with the gland in all classes of molluscs excluding the Cephalopoda. References to practically all important contributions on the subject are included, but preliminary and incomplete papers are not reviewed. The accounts of Balfour (3) and Korschelt and Heider (88) are incomplete and out of date, while Heschler (73) and Macbride (109) refer only to the shell-gland in the forms the embryology of which they include in their works.

The work on the Viviparidae and some of the general papers are considered separately in the beginning. Following Pelseneer's classification (128) the review of the literature for the different classes of Mollusca is treated under the following heads:—

(1) Amphineura, (2) Gastropoda under the divisions Aspidobranchia, Pectinibranchia, Opisthobranchia and Pulmonata, (3) Scaphopoda, and (4) Lamellibranchia under the orders Protobranchia, Filibranchia and Eulamellibranchia. The literature is treated chronologically, but papers dealing with nearly related forms are discussed together.

Viviparidae and General.—Leydig (102) was the first to describe the development of the mantle of *Viviparus viviparus*. He referred to the mantle in its connection with the secretion of the shell, but did not find the shell-gland of the embryo or of the adult. In his account of the mantle without recognizing their true nature he, however, described the cells which later form the supramarginal ridge of the mantle of the adult. Lereboullet (101) gave good figures of various stages in the development of the larval shell-gland of *Limnaea*, but did not understand its significance and considering it to be connected with the anal invagination called it the "tube rectal." Ganin (59) appears to be the first who understood the connection of this area with the shell-gland of the embryo and its relation with the mantle. It was not, however, till Lankester (95) discovered the structure in the centre of the aboral pole of the embryo of *Aplysia* that its true nature was understood. He called it the "shell-gland," but made no remarks about its relation to the shell-gland of the adult. In the following year Lankester (96) recorded the gland in the embryos of other molluscs, and this was followed by a detailed paper (98) in which he described and figured the "existence of a specially differentiated patch of epidermal cells at the aboral pole, which develops a deep furrow, groove, or pit in the centre, almost amounting to a sac-like cavity opening to the exterior. The first (chitinous) rudiment of the shell appears as a disk on the surface of this gland, but also in some cases the cavity or groove is filled by a chitinous plug." He further suggested the homology of the gland which secretes the internal shell or the "pen" of the Cephalopods with the embryonic shell-gland of the Gastropods and Lamellibranchs. This theme was elaborated in two other papers (97, 99), but from his studies of the fossil forms he now concluded that the two structures are

¹ Andersen, K.—*Morphologisch. Jahrb.* LIII, pp. 211-258, pl. vii (1924).

different. Leaving aside the Cephalopods he had so far found the shell-gland in the embryos of the molluscs *Aplysia*, *Neritina*, *Limnaea* and *Pisidium*, but in two contributions (99, 100) he described a similar shell-gland in the embryos of *V viviparus*. The structure of the gland was not described nor its later development followed. He, however, noted that even after the shell assumes a dome-like shape "the pit of the shell-gland is still in existence and is filled by a chitinous knob of the shell."

The work of Fol (52-56), though it does not deal with the development of *Viviparus*, should be referred to here. Fol is the only author who, so far as I can find from the literature, distinguished between the shell-gland of the embryo and that of the adult, and gave detailed descriptions of the structures concerned. In his paper on the development of the Pteropods (53) he included a good summary of the earlier literature on the development of the shell and its relation to the mantle in all classes of molluscs. In Pteropods, Heteropods and pulmonate Gastropods, Fol found the embryonic shell-gland to develop on the aboral pole from a thickening of the ectodermal cells. This area later becomes invaginated and forms a definite pit (l'invagination coquillière ou préconchylienne), which was found to be filled with a trabecular secretion; this latter in some forms was seen to spread on the surface of the embryo and harden into a shell. The fate of the invagination was found to be different in various molluscs, it either disappeared entirely or persisted in part and marked the region from which the mantle develops. Fol distinguished the larval shell (la coquille larvaire) from the shell of the adult (la coquille définitive). The larval shell was found either to persist and form the first part of the adult shell or to disappear in part or altogether. The adult shell, he concluded, was secreted by the mantle margin, while its inner surface, in most forms, was strengthened by the deposition of shelly secretions from the general epithelial covering of the whole mantle. Agreeing with Lankester he considered the embryonic shell-gland to be the same structure in Lamellibranchs and Gastropods, and homologous with the pit which secretes the internal shell of Cephalopods. In his paper on the pulmonate Gastropods (56, c) he figured a transverse section of *Limnaea palustris* (p. 152, fig. 4) and a sagittal section of *L. stagnalis* (p. 153, fig. 5). In the first figure he called the mantle margin the shell-band (le bourrelet coquillière), while in the second he simply designated it as the mantle margin. In the second figure, which is a section of an advanced embryo, he represented the flask-shaped *anlagen* of the unicellular shell-glands of the adult without recognising their true significance.

Bütschli (23) confirmed Lankester's observations regarding the development of the shell-gland in the embryo of *V viviparus*, and described the formation of a chitinous plug (Conchyolinpfropf) in the invaginated gland, the appearance of which, according to Bütschli, marks the beginning of the growth of the larval shell and probably also of the allied mantle structures. He further found that soon after the completion of the development of the shell-gland the invagination disappears and its cells become flattened. In his account he confused the margin of the mantle, which is separated about the same time, with the shell-gland of the embryo.

Blochmann (9) noticed in embryos of *V viviparus* in the gastrula stage the separation of the shell-gland on the aboral pole. The ectoderm in this region is thickened and consists of tall, narrow cells.

Erlanger (43) in his classical work on the embryology of *V. viviparus* included a few remarks on the origin and the development of various stages of the shell-gland. The youngest embryo in which he saw the beginning of the shell-gland was 0.09 mm. in length, it had a well developed velum, but the mesoderm had not yet been differentiated. The shell-gland at this stage consists only of a thickened patch of ectodermal cells on the dorsal surface of the embryo. In somewhat older embryos with spindle-shaped mesodermal cells, the shell-gland becomes separated and extends from the velum to the anus. It is now a rounded plate formed of tall, cylindrical cells. He did not describe the invagination of the larval shell-gland, its transformation, and the appearance of the *anlagen* of the shell-gland of the adult. He, however, described in an embryo of 0.64 mm. the embryonic shell as membranous and added that its margins are embedded in a furrow just above the thickened mantle margin, which he considered to be responsible for the further secretion of the shell and called it the shell-groove (Schalenfalz). In the second part of his paper he gave a good figure of the invaginated shell-gland (Pl. xxxii, fig. 1) with its chitinous plug (Schalenknopf). In another figure of a fully grown embryo he showed a large number of glands in the mantle lying just behind the margin, and labelled these the glands of the mantle margin (Drüsen des Mantlerandes); these glands, the true nature of which was not understood by Erlanger, are functional even at this stage of the embryonic life and ultimately become the shell-glands of the adult.

Drummond's remarks about the embryonic shell-gland and its ultimate fate are very incomplete and inaccurate in her otherwise excellent paper (40). In the youngest embryo observed she found the shell-gland to consist of a deep pit widely open to the exterior. In the second stage the shell-gland is "partially evaginated, and begins to form the visceral hump" Whatever the fate of the embryonic shell-gland may be it certainly never forms the visceral hump either of the embryo or of the adult. Drummond casually referred to the development of the mantle and the mantle fold, but did not recognise the *anlagen* of the shell-gland of the adult in it.

Tönniges (168) included a few notes about the development of the shell-gland and the changes undergone by it during its transformation into the shell-gland of the adult. He described the shell-gland as a thickening of the ectoderm on the dorsal surface extending from the velum to the anus of the embryo in the trochophore stage. In the next stage the gland was found to become invaginated and compressed against the dorsal wall of the primary gut. The invagination later becomes more marked and is filled by a chitinous plug (Bütschli's Conchyolinpfropf). At a slightly later stage, when the mantle is beginning to be differentiated, the shell-gland cells become much flatter and a thin membranous shell begins to appear. The shell is supported somewhat later along its free margins in the mantle-groove. Good figures of the shell-gland and associated structures are also included in the paper. Otto and Tönniges (126) further extended the observations of Tönniges referred to above. Their account of the earlier stages is a confirmation of the earlier work of Tönniges, but they also described the fate of the embryonic shell-gland, the chitinous plug and the relation of the shell to the mantle and the mantle groove. They considered the great development and the height of the cells of the embryonic shell-gland in its earlier stages as being due to the great activity of the cells for the secretion of the embryonic shell.

The stage after the invagination of the shell-gland is described in detail, and it was found by the authors that after this stage the tall epithelial cells of the shell-gland, in conformity with the great activity in the development of the other organs of the embryo, become quite flat. The membranous shell at this stage spreads itself over the dorsal surface of the embryo and the first trace of the mantle-fold begins to appear. The further development of the mantle-furrow is also described. Anderson, in the paper cited, has given a very detailed and complete account of the changes undergone by the embryonic shell-gland, the development of the mantle, the pallial cavity and their relations to the general form of the embryo. He does not give any details of the histological structure, but these will be found in the works of Otto and Tönniges.

Amphineura.—Kowalevsky (89) did not correlate the conditions in the Chitonidae with those in other molluscs, and it is not clear from his account that any thickening of the shell-gland area takes place in the early embryo, and whether there is an invagination and later evagination of the shell-secreting areas. The shell-secreting area is divided into seven grooves corresponding to the seven calcareous plates of the shell (the eighth plate is not secreted till later in embryonic life), but as was pointed out by Korschelt (88) its development is otherwise similar to that of the shell-gland in other molluscs. In the formation of the shell the tegumentum is first secreted and the articulamentum is laid under it later on. Heath (70), who studied the cell-lineage in *Ischnochiton*, found that the shell-secreting areas are derived from the ectomeres and apparently three quartettes take part in the formation of the various shell-patches and the mantle. In Solenogastres the only account is the short paper on the development of *Dondersia (Myxomenia) banyulensia* by Pruvot (133). The shell-gland and its development in this form are not described by the author, but seven rows of plates are shown to develop on the dorsal surface of the embryo. These rows of calcareous plates, as was pointed out by Heschler (73), recall the seven shell-valves of Chiton, and it is possible that in the embryos of Solenogastres the plates are secreted by glands similar to those of Chiton.

Gastropods.—A good general review of the shell-gland for some Gastropods was published by Pelseneer (129) but a great deal of the earlier work is not reviewed in his masterly memoir.

Aspidobranchia.—In *Patella coerulea* Patten (127) found that the shell-gland begins to be differentiated on the aboral pole posterior to the velum shortly before the closure of the blastopore. It consists of a flat plate of tall, columnar ectodermal cells, which begin to extend at its outer margins. In the middle of its external surface is formed a large depression or invagination which becomes very extensive and appears Y-shaped. According to Patten it seems to “exert modifying influence upon the processes which take place within the interior of the embryo”. Later with the flattening and evagination of the gland the lateral and posterior extensions are reduced, and the area, except along its margins, which are thick and later develop into the mantle, consists of flattened cells. The membranous shell is secreted during the invaginated stage of the gland and is later strengthened by the secretion of calcareous matter. Wilson (175) does not definitely state the cells from which the shell-gland in *Patella* is derived, but he observed its formation as a thickened plate of ectodermal cells on the dorsal surface behind the prototroch.

In *Haliotis* Boutan (15) did not describe the earlier stages, but noted the formation of an invaginated shell-gland. According to him the shell is secreted by this gland, and in the earlier stages is coiled like that of other Gastropoda. Later Boutan (17) also referred to the formation of the shell-gland in *Haliotis*, *Acmaea*, *Fissurella* and other Aspidobranchs, but did not go into details.

In *Neritina* Claparède (27) saw the shell at an early stage, but did not detect the shell-gland, nor did he describe the secretion of the embryonic shell and the development of the mantle. He, however, connected the further secretion of the shell with the mantle, but did not distinguish any shell-gland region in it. Lankester (98) described the invaginated gland filled with a chitinous plug, but did not deal with the various stages in its development. Blochmann (8) did not give a detailed account of the embryonic shell-gland in *Neritina*, but in the oldest embryo observed by him he figured the shell-gland as a somewhat concave plate with a shallow invagination in its centre.

Boutan (14) studied the embryology of a number of species of the genus *Fissurella*. In all these species the embryonic shell-gland was found to arise on the aboral pole and soon became invaginated, and the first rudiment of the shell was secreted. The invaginated area later flattened out and the mantle originated from its margins. The formation of the shell, which in the earlier stages is coiled like that of other Gastropods, and its transformation into a cup-shaped shell are also described in detail.

Robert (141) in the case of *Trochus* agreed with Conklin (28) that the shell-gland was a derivative of the 2d cell of the developing egg.

Pectinibranchia.—In *Ampullaria* Semper (153) did not detect the earlier stages in the development of the shell-gland. In the first stage described by him the shell-secreting area is in the form of an oval plate of flat, polygonal cells, which apparently represents the stage after the evagination and flattening of the cells of the shell-gland. In an older embryo he noted the shifting of the shell-secreting area to the place where the mantle originates. The development of the shell was also described but its secretion was not definitely connected with any glands in the mantle or elsewhere.

Bobretzky (10) saw a circular invagination in the young embryos of *Nassa mutabilis* which he described as the "Schalengrube" Later the gland became everted and a cuticular shell was secreted over it. He noted that the shell grows along the margins in the thickened marginal zone of the shell-gland, which he distinguished as the "Anlage des Mantels" After its evagination the shell-gland is lined by flattened cells which become still thinner. In *Fusus* and *Natica* the development of the shell-gland was found to be similar to that in *Nassa*.

In *Calyptraea sinensis* Salensky (143) noticed an invagination on the dorsal surface of the embryo in the middle of the Mantel-Anlage and covered by a plate-like rudiment of the shell, which is free in the middle but embedded in the mantle thickening along the margins. He, however, did not recognize in this invagination the shell-gland of the embryo and did not describe its further development.

Sarasin (146) described the development of the embryonic shell-gland in *Bithynia tentaculata*. His account is not very clear and in the earlier stages he appears to have confused the invagination of the shell-gland with the blastopore. The later stages are not

described in detail, but good figures illustrating the everted gland and, in still older embryos, its flattened cells covering the visceral mass accompany his paper. He described the development of the mantle from the marginal region of the shell-gland, and without recognizing their true nature figured the anlage of the shell-glands of the adult in the mantle margin. Erlanger (44) gave a detailed and accurate account of the shell-gland in the same species. The shell-gland was found to appear soon after gastrulation as an ectodermal thickening on the dorsal surface in the post-velar area. Later it shifts to the left and lying opposite the oral invagination produces the first signs of asymmetry in the developing embryo. In the next stage the gland is invaginated and a thin cuticular shell is secreted over it. The evagination, flattening and spreading of the gland cells and the development of the shell-furrow and the mantle ridge are also described. He does not give any account of the development of the shell-gland of the adult, but from his text and figures it appears that he saw the gland-anlage in the mantle-furrow.

Salensky (145) described the shell-gland in *Vermetus* as the "glands préconchylienne". It was distinguished on the dorsal surface of the embryo as an insignificant invagination lined by tall ectodermal cells. Salensky casually referred to its connection with the secretion of the shell and the development of the mantle, and added that its further history is the same as in other molluscs.

McMurrich (110) remarked that the "shell-area" in *Fulgur* is formed in the same way as in other molluscs. He saw the invagination of the gland but considered it to be of unknown significance. Conklin (29) gave a detailed account of the shell-gland in *Fulgur*. He described the shell-gland as one of the earliest and largest of the developing organs and the one most instrumental in shaping the form of the embryo. It was found to develop as an aggregation of ectodermal cells in the mid-dorsal plane posterior to the apical pole. The cells forming it are probably derived from the ectomere *2d* and by an increase in their numbers cause a saucer-shaped depression in this area. The depression becomes deeper and subsequently evaginates. The thickened margin forms the mantle-ridge, while the central part, which is formed of a layer of flat ectoderm cells, is covered by a thin cuticular shell. Conklin had previously (28) described the shell-gland of *Crepidula* in detail. In this Gastropod the shell-gland arises from the cell *2d*, the first somatoblast, also called *X* by many authors. He also noted that the development of this area seems to be similar in the various forms which have been studied, and that it gives rise to the first shell, the mantle-edge and fold, and the layer of cells which covers the yolk under the shell.

Delsman (36) described the various stages in the development of the shell-gland and the mantle in *Littorina obtusata*. The development is similar to that in other Gastropods noted above and the gland arises in the same way. The author did not recognize in the mantle the anlage of the shell-gland of the adult.

The work of Fol (56, b) on Heteropods has already been referred to but a few notes may be included here to make this summary complete. In these forms simultaneously with the closing of the blastopore the shell-gland is formed as an invaginated pit on the aboral pole. Later it becomes everted and an embryonic shell is secreted in all forms whether they are with or without a shell in the adult. The embryonic shell is completely lost in *Pterotrachea*, *Firolloidea* and allied forms, and exists as a rudimentary structure in

Carinaria. The mantle is developed from the margins of the gland, but in forms without a shell in the adult it degenerates later.

Opisthobranchia.—The first discovery of the shell-gland in *Aplysia* by Lankester (95) and his detailed account of the gland in two species (98) has already been referred to. Blochmann (9) described the earlier stages in the development of *Aplysia limacina*, and noted that the earlier rudiments of the shell-gland described and figured by Lankester do not represent the shell-gland but only an ectodermal cell aggregate; the true gland-anlage being situated higher up towards the animal pole. He traced the stages from a flat plate of columnar cells to a fairly deep pit formed by invagination on the aboral pole diametrically opposite the oesophageal invagination. The cells of the pit were later found to spread outwards and become flatter in the greater part of the gland, while the marginal area remained thick and formed the mantle. Mazzarelli (113) gave good figures and described the various stages in the development of a number of species of Aplysiidae, and fully confirmed the account of Blochmann. Georgevitch (62) studied the embryology of *Aplysia* paying special attention to cell-lineage, and though his account of some of the earlier stages and the formation of the mesoderm has been criticised by Carazzi (24), his paper fully confirms the earlier work of Blochmann and others. It is also the best connected account of the formation of the shell-gland in this Opisthobranch.

Rho (139) did not enter into details of the development of the shell-gland, but described and figured most of the stages in *Chromodoris*. Heymons (74) did not describe the history of the shell-gland in *Umbrella mediterranea* in detail, but referred to its appearance close to the "anal cells." In a figure of a 24 days embryo he shows the gland as a pit. In a 31 days embryo the first rudiment of the shell is figured over the evaginated pit of the gland, and the mantle is beginning to be differentiated. In a 34 days embryo the shell-fold of the mantle can be distinguished, while the greatly flattened cells of the gland are spread over the surface of the embryonic visceral mass. Lacaze-Duthiers and Pruvot (94) described the various stages in the formation of the shell-gland or the preconchylian invagination on the aboral pole of the embryo of *Philine*. The later stages in the evagination of the gland, the flattening of the cells and the formation of the mantle are also described. Viguiet (170) did not trace the earlier stages in the development of the shell-gland in *Tethys*, but figured and described the invaginated gland, and referred to the role of the mantle in the secretion of the shell in the later stages. Casteel (26) carefully described all the earlier stages in *Fiona*. He found that at quite an early stage there is great activity in the area between the posterior limb of the "cross" and the blastopore, and the cells on the posterior and upper surface of the gastrula are specially high. The centre of the area is then invaginated and the lower wall of this pit pushes the enteron below it. With the growth of the lower part of the invagination its margins become greatly constricted above and are distinguished by a ring of large granular cells. Shortly afterwards the invaginated area opens outwards and forms a thick-celled cap on the posterior surface of the veliger larva. The gland also spreads with the growing larva and its cells become much flatter, while the shell appears on its surface. The cells along the margin of the area, which are specially concerned with the secretion of the shell, are marked by their large size and apparently represent the mantle-anlage. He found that from a very early stage the shell-gland

is displaced slightly to the left of the body, and with its growth the lack of bilateral symmetry becomes marked in the developing larva.

Fol's work (56a) on Pteropods, noticed already, may be briefly reviewed here. He observed that the shell-gland is formed as a pit on the aboral pole of the embryo. Later the pit is everted and its cells become flattened except along the margins where they form the mantle. The shell is secreted shortly before the evagination of the pit and is supported by the thickened mantle zone. In all Pteropods a shell is secreted in the embryonic stage even though it is absent in many forms in later life.

Pulmonata.—Gegenbaur (61) did not describe the earlier stages in the development of the shell-gland, but gave a good account of the later stages in *Limax* and *Clausilia*. In the earlier stages the shell in both genera is enclosed in a sac. In *Limax*, which has an internal shell throughout its life, the sac remains closed, but in *Clausilia* Gegenbaur found that the shell becomes external by the disappearance of the dorsal wall of the shell-sac and the mantle which lie over it. Heider (88) explained this peculiarity of an internal shell in *Clausilia* by supposing that a small opening, not noticed by Gegenbaur, probably persists in the roof of the shell-sac, thereby implying that the sac is not fully closed at any time of its development, and added that in this case the shell-gland does not evaginate till late in life. Schmidt (150) investigated the development of *Limax*, *Clausilia* and *Succinea* and, though he did not deal with the very early stages, was able fully to confirm Gegenbaur's work. In *Clausilia* and *Succinea* he found that the shell-gland soon after its invagination is separated from the outer ectoderm as a closed sac lying between the outer mantle-covering and the dorsal wall of the intestine. He described the various stages in the development of the closed shell sac and found that the first shell is secreted inside it as a thin cuticular membrane. Later the dorsal wall of the sac fuses with the mantle wall over it, and in this fused membrane an opening appears. The shell protrudes through this aperture and gradually becomes an external structure. Schmidt inferred from these observations that probably in all Stylommatophora the first shell is formed in a closed sac, and that in those with an internal shell the gland throughout life remains a closed sac. In *Limax* Kofoed (86) described only the first appearance of the shell-gland as an area of ectodermal cells which are specially marked by their large size. Meisenheimer (115a, b) gave a detailed account of the shell-gland in *Limax*. He confirmed the work of Schmidt and stated that the earlier details in the development of the closed shell-gland of *Limax* are similar to those of other Gastropoda.

Jhering (80), in his paper on the embryology of *Helix*, strongly criticised Lankester's account of the structure which the latter author described as the shell-gland in the embryos of some molluscs and stated that the structure was the mantle-anlage. He described the embryonic shell, but did not specify the region by which it is secreted. Later (81) he corrected his mistake about the shell-gland and added that the area represents the shell-gland and the mantle-anlage.

Joyeux-Laffuie (83) described in *Oncidium* the "invagination coquillière" on the aboral pole of the embryo, but did not deal with the earlier stages in its development. He included an account of the formation of the mantle and the secretion of a coiled shell like that of other Gastropoda, which is thrown off during the embryonic period.

The work of Lereboullet (101), Ganin (59), Lankester (96, 98) and Fol (56, c) on freshwater Pulmonates has already been reviewed. Rabl (134) studied various freshwater genera, *Physa*, *Planorbis*, *Limnaea* and *Ancylus*, but gave a detailed account of the development only in *Physa*. Like many other authors he confused the invagination of the shell-gland with the anal invagination, but in his later paper on *Planorbis* (136) he correctly interpreted the structures and, agreeing with Lankester, Fol and Bobretzky, called the aboral invagination the shell-gland. He, however, remarked that it was impossible to understand the physiological significance of the early appearance of this structure. Wolfson (177) gave a lucid account of the formation of the shell-gland and the mantle in *Limnaea stagnalis*. He found that the shell-gland is differentiated in the gastrula stage on the aboral pole of the embryo as a flattening of the ectoderm, which later becomes invaginated. With the growth of the foot the invagination shifts towards the head-end. In older embryos the invagination everts and forms a watchglass-shaped structure which is the anlage of the shell-gland and the mantle. Holmes (75) studied the cell-lineage of *Planorbis*. He found that the shell-gland first appears on the aboral pole a short distance behind the tip of the posterior arm of the "cross" in the region of the cells of the second quartette soon after the closure of the blastopore. He added that the gland is doubtless formed by the derivatives of the cells $2d^{1-2}$ and $2d^{2-1}$. Wierzejski (173) did not deal with the formation of the shell-gland in *Physa* in detail, though he noted that it is derived from the $2d$ cell. From his excellent figures it is clear that the later development of the shell-gland in *Physa* does not differ from that in other Gastropoda.

Scaphopoda.—Kowalevsky (90) described the larva of *Dentalium* as similar to the trochophore larva of the Annelida. The larva at an early stage develops the shell-gland on its dorsal surface as a thickening of the ectoderm. This plate-like thickening of ectoderm cells becomes invaginated and forms a cup-shaped cavity. Later, as in other molluscs, the cavity evaginates and spreads to form a saddle-shaped structure resembling the shell-gland of Lamellibranchs at this stage. A saddle-shaped shell is secreted by this gland, and the tubular shell of the adult results by the fusion of the ventral margins of the growing shell, as was previously described by Lacaze-Duthiers (93). The mantle originates from the margins of the saddle-shaped gland as in Lamellibranchs. Wilson (175) confirmed the work of Kowalevsky and from his account of the cell-lineage in *Dentalium* it is clear that the gland arises from the region of the posterior arm of the "cross," and from descendants of the somatoblast corresponding to $2d$ in other molluscs.

Lammellibranchia. Protobranchia.—Drew (37) described in embryos of *Yoldia limatula* an unpaired shell-gland on the dorsal surface. Later the area is invaginated, but soon afterwards the sides arch upwards preparatory to protruding laterally to form the mantle. In older embryos the gland becomes localized at the edges where the cells remain large and granular, while further upwards they are flat like the cells of the mantle. The next stage shows the two valves of the shell secreted by the gland. In *Nucula delphinodonta*, according to Drew (38), the shell-gland is formed quite early on the dorsal side of the embryo near the head. Later the gland flattens slightly, but the edges remain raised and separated from the test, and at no stage it is really invaginated. In older embryos the gland, owing to the multiplication and flattening of its cells, arches upwards and comes to lie close to the test,

while a space appears between it and the archenteron: The saddle-shaped structure which results from these changes begins to secrete the two valves of the shell on the two sides, and the mantle-folds are formed laterally by the growth of the lower edges of the saddle-shaped gland.

Filibranchia.—Barrois (4) shortly described the development of the shell-gland and the mantle in *Mytilus edulis*, and this species was also investigated by Wilson (176) without reference to Barrois's work. He described the shell-gland "as a distinctively refractive body near the velum" which has been often confused with the blastopore. He did not describe the later changes in detail, but noted that the gland soon assumes a bilateral form. Delsman (35) does not go into details about the shell-gland, but a more detailed account has since been published by Field (45).

Fullarton (58) referred to the shell-gland in *Pecten opercularis* as the preconchylian gland, but did not trace the earlier history. Drew (39) described the unpaired shell-gland anlage in *Pecten tenuicostatus*, and stated that its development is not different from that of other Lamellibranchs. The shell-gland is differentiated on the future dorsal surface and lies diametrically opposite the stomodaeal invagination. In the invaginated stage the inner wall of the gland lies close to the upper wall of the archenteron, and later the gland begins to spread, evaginates and grows down on the two sides laterally to form the mantle.

Eulamellibranchs.—In the embryos of *Cyclas* or *Sphaerium* Stepanoff (163) correctly figured the shell-gland, but did not recognize its true nature for he called it the anlage of the mantle. Ganin (59) and Lankester (95, 98) independently worked out the true significance of the structure in *Sphaerium* and *Pisidium*, and connected it with the secretion of the embryonic shell and the formation of the mantle. Jhering (81) also correctly described the shell-gland in *Sphaerium*, but the most detailed account was published by Ziegler (178). According to Ziegler the gland is separated as a saddle-shaped invagination of the ectoderm on the dorsal surface of the embryo behind the head-rudiment. The invagination proceeds until its upper margins meet in the middle and then begins to evaginate and spread out. The first shell is now secreted, and Ziegler suggested that it is probably secreted by only the outer marginal cells of the area. He described the development of the mantle from the lateral margins of the gland and referred to its connection with the secretion of the two valves of the adult shell. He further remarked that the shell-gland of all Gastropoda and Lamellibranchia is similar in form and position.

Flemming (47) did not recognize the shell-gland in the early stages of the Unionidae, but later (48) considered the dark macromeres as probably representing the shell-gland. Rabl (135) confused the invagination of the shell-gland with the blastopore. Schierholz (148) confused the shell-gland with the invagination of the intestine, but later (149) described the unpaired shell-gland in the Unionidae and connected it with the secretion of the first shell and the formation of the mantle. Goette (63) critically reviewed the earlier work on the development of the Unionidae, and described the various stages from the thickening of the shell-gland plate, its invagination, evagination and flattening to form a saddle-shaped structure, which secretes the two shell-valves and forms the mantle on the two sides. Lillie (104), who studied the cell-lineage of the Unionidae, found that the shell-gland is derived from d^2 or the ectomere X , which he called the protoblast of the shell-gland. The shell-

gland is formed as a plate of columnar cells by the repeated divisions of the ectomere, and its later development is the same as described by Goette.

Davaine (33) and Lacaze-Duthiers (92) noticed in the embryos of *Ostrea* a pit (*echancrure* or depression), which is the shell-gland, but did not understand its significance. Salensky (144) stated, and Fol (56, a) repeated that the shell-gland in *Ostrea* shows only a feeble excavation of the thickened epiblast and does not form a true invagination. Brooks (21) in *Ostrea virginica* confused the early stages of the invagination of the shell-gland with the blastopore, but correctly described the later stages. Horst (76, 77) gave a correct account of the shell-gland in *Ostrea edulis*. He found that the gland is formed on the animal pole as an invagination of the ectoderm. Later it is evaginated and is transformed into a saddle-shaped thickening. The first shell is unpaired and the mantle develops from the lateral extensions of the area. Meisenheimer (116) remarked that from a study of Horst's figures and descriptions that in some of the very early stages Horst, like the earlier authors, had confused the shell-gland and the midgut. Kent (84) figured some of the later stages in the development of the Australian rock-oyster (*O. glomerata*) but did not give details. Macbride (108) in the Canadian oyster referred to the development of the shell-gland which first appears on the back of the embryo as a pit and then flattens out and becomes saddle-shaped at the sides of which the first shell is formed as two calcareous particles. Stafford (161) gave a good summary of the previous work and confirmed the work of Horst to some extent. He, however, rightly added that most of the details about the shell and the shell-glands still remain to be worked out.

Hatschek (69) described in *Teredo* embryos a shell-gland in the preoral area, the development of which in the earlier stages is, according to the author, similar to that of Gastropods. The shell-gland is originally a flat plate, but later invaginates and forms a shallow sac which later evaginates and flattens out to form the mantle, and secretes the two shell-valves. In the earlier stages, as Meisenheimer (116) correctly pointed out, Hatschek had confused the anlage of the shell-gland with that of the midgut.

Meisenheimer (116) gave a detailed account of the development of the shell-gland in *Dreissensia polymorpha*. He found that as in the Unionidae and other Molluscs the shell-gland is derived from the first somatoblast *X*. It passes through the invagination and evagination stages similar to those of other bivalves and is unpaired in the young embryos. Its further development and the formation of the mantle proceed as in other Lamellibranchs.

Summary.—In all classes of molluscs, except the Cephalopods, the so-called shell-gland is differentiated shortly after gastrulation on the dorsal surface of the developing embryo. In various molluscs the cell-lineage of which has been followed, the gland is developed from the descendants of the first somatoblast or what is designated *2d* or *X* by different authors, and it may, therefore, be assumed that probably in all molluscs it is formed from the same region of the developing egg. The area of its appearance lies behind the velum near the end of the posterior limb of the "Molluscan Cross", and is formed of tall, cylindrical, probably glandular cells. At this stage the cells of this region are actively dividing, and as a result of this activity the central part of the area becomes concave and later invaginated as a cup-shaped structure.

The invagination is probably due to physical causes only. The cells in the area have greatly increased in numbers and must either spread over the adjoining regions or the plate be invaginated as a cup. Space being available between it and the dorsal wall of the archenteron the latter course is adopted.

With the continued division of the cells, however, the invaginated part becomes too large for the available space, and evaginates forming a flattened plate over the postero-dorsal surface of the developing embryo. As a result of continued division most of the cells of the plate have by this time become thin and flattened, and only the marginal cells retain their original glandular character.¹ A thin cuticular shell has meanwhile been secreted over the area ; it is separated from the plate of cells in the greater part of its surface but is embedded along the margins in the thick marginal zone. There is no general agreement as to the region which secretes the first rudiment of the shell. Lankester, Fol, Bütschli and Erlanger have in *Viviparus*, *Aplysia* and some Pteropods and Heteropods described a chitinous plug filling up the cup of the invaginated gland. Fol in some of the Heteropods definitely described this chitinous structure as spreading over the invaginated pit, and forming the first shell. No such structure has, however, been described in the large majority of other molluscs, the embryology of which has been carefully investigated, and it seems doubtful whether the formation of the first rudiment of the shell takes place in the way suggested by Fol. In *Sphaerium*, Ziegler was of opinion that probably only the marginal zone, which also forms the shell-secreting zone of the adult, secretes the first shell. This view seems to be more in accord with the general conditions and is the one suggested by the accounts of several of the more recent workers.

The main part of the area, *viz.*, the central part consisting of thin flattened cells, form the outer covering of the visceral mass of the adult in the Gastropods, and the upper part of the mantle-flaps in the Lamellibranchs and Scaphopods. The marginal zone consisting of the tall, glandular cells is transformed into the mantle and is mainly responsible for the production of the adult shell.

The two names usually employed for this embryonic structure *Shell-gland* (Lankester) and *l'invagination préconchylienne* (Fol) are in view of the above conclusion quite inappropriate.

9. LIST OF REFERENCES TO THE LITERATURE.

1. Annandale, N.—The edge of the mantle and the external ornamentation of the shell in the Banded Pond-Snail of India. *Rec. Ind. Mus.* XXII, pp. 243-266, pl. iii (1921).
2. Annandale, N.—The evolution of the Shell-Sculpture in Freshwater snails of the family Viviparidae. *Proc. Roy. Soc. London* (B) XCVI, pp. 59-76 (1924).
3. Balfour, F. M.—A Treatise on Comparative Embryology. Vol. I, London (1880).
4. Barrois, T.—Note sur l'embryogenie de la Moule commune (*Mytilus edulis*). *Bull. Sci. Nord France* (2) II, pp. 137-146, 1 plate (1879).
5. Beck, K.—Anatomie deutscher Buliminus-Arten. *Jenaisch. Zeitschr. Naturwiss.* XLVIII, pp. 187-262, pls. viii-x (1912).

¹ The condition of a fully closed sac-like gland in the Stylommatophora is secondary and is not considered here.

6. Biedermann, W.—Untersuchungen über Bau und Entstehung der Molluskenschalen. *Jenaisch. Zeitschr. Naturwiss.* XXXVI, pp. 1-164, pls. i-vi (1901).
7. Biedermann, W.—Physiologie der Stütz- und Skeletsubstanzen. VI. Die Schalen und Gehäuse der Mollusken. *Winterstein Handbuch der Vergleichende Physiologie*, III, pp. 760-766 (1914).
8. Blochmann, F.—Über die Entwicklung der *Neritina fluviatilis* Müll. *Zeitschr. wiss. Zool.* XXXVI, pp. 125-174, pls. vi-viii (1881).
9. Blochmann, F.—Beiträge zur Kenntnis der Entwicklung der Gastropoden. *Zeitschr. wiss. Zool.* XXXVIII, pp. 392-410, pls. xx, xxi (1883).
10. Bobretzky, N.—Studien über die embryonale Entwicklung der Gasteropoden. *Archiv Mikr. Anat.* XIII, pp. 95-169, pls. viii-xiii (1877).
11. Boll, F.—Beiträge zur vergleichenden Histologie der Moluskentypus. *Archiv Mikr. Anat.* V Supplement, pp. 1-112, pls. i-iv (1869).
12. Bouchard-Chantreaux, N. R.—Catalogue des Mollusques terrestres et fluviatiles observés jusqu'à ce jour à l'état vivant dans le département du Pas-de-Calais. *Mem. Soc. Agric. Boulogne*, Ser. II, Vol. I, pp. 141-230, 1 pl. (1837). Separate copies (1838).
13. Bournon, E. de, *Traité complet de la chaux carbonatée et de l'aragonite*. Vol. I, London (1808).
14. Boutan, L.—Recherches sur l'anatomie et le développement de la Fissurelle. *Arch. Zool. exper. Gén.* III Supplement (2), pp. 1-173, pls. xxxi-xliv (1885).
15. Boutan, L.—Sur le développement de l'*Haliotidae* et sur l'utilité du Scaphandre dans les recherches zoologiques. *Compt. Rend. Ass. France*. II, pp. 522-525 (1892).
16. Boutan, L.—Sur le développement de l'*Acmaea virginea*. *Compt. Rend. Acad. Sci. Paris*, CXXVI, pp. 1887-1889 (1898).
17. Boutan, L.—La cause principale de l'asymétrie des Mollusques gastéropodes. *Arch. Zool. exp. Gén.* (3) VII, pp. 203-342 (1899).
18. Bowerbank, J. S.—On the microscopic structure of the shells of Molluscous and Conchiferous Animals. *Trans. Microscop. Soc.* I, pp. 123-157, pls. xiv-xviii (1844).
19. Bregenzer, A.—Anatomie und Histologie von *Bythinella dunkeri*. *Zoologisch. Jahrb. (Anat.)*, XXXIX, pp. 237-292, pl. xvi (1915).
20. Bronn, H. G.—Kopfflosse Weichthiere in Bronn, *Die Klassen und Ordnungen der Thier-Reich*. Vol. III, pt. 1 (1862).
21. Brooks, W. K.—The development of the American Oyster (*Ostrea virginiana* List.). *Stud. Biol. Lab. Johns Hopkins Univ.* IV, pp. 1-106, pls. i-x (1880).
22. Burkhardt, F.—Das Körperepithel von *Helix pomatia* L. *Inaug. Dissert. Marburg*, pp. 1-30 (1916).
23. Bütschli, O.—Entwicklungsgeschichtliche Beiträge. I. Zur Entwicklungsgeschichte von *Paludina vivipara* Müll. *Zeitschr. wiss. Zool.* XXIX, pp. 216-232, pls. xv-xviii (1877).
24. Carazzi, D.—L'embriologia dell' *Aplysia limacina* L. fino alla formazione delle strisce mesodermiche. *Anat. Anz.* XVII, pp. 77-102 (1900).
25. Carpenter, W. B.—On the Microscopic Structure of Shells. II. *Reports Brit. Ass. Adv. Sci.* pp. 93-134, pls. i-xx (1847).

26. Casteel, B. D.—The Cell-lineage and Early Development of *Fiona marina*, a Nudi-branchiate Mollusk. *Proc. Acad. Nat. Sci. Philadelphia*, pp. 325-405, pls. xxi-xxxv (1904).
27. Claparède, R. E.—Anatomie und Entwicklung der *Neritina fluviatilis*. *Müllers Arch.* pp. 194-248, pls. vii, viii (1857).
28. Conklin, E. G.—The Embryology of *Crépidula*: A contribution to the cell-lineage and early development of some marine Gasteropods. *Journ. Morphol.* XIII, pp. 1-226, pls. i-ix (1897).
29. Conklin, E. G.—The embryology of *Fulgur*: A study of the influence of yolk on Development. *Proc. Acad. Nat. Sci. Philadelphia*, pp. 320-359, pls. xxiii-xxviii (1907).
30. Cooke, A. H.—Molluscs in *The Cambridge Natural History*, Vol. III, London (1895).
31. Cuvier, G.—Memoires pour servir à l'histoire et à l'anatomie des Mollusques. Paris (1817).
32. Dakin, W. J.—Buccinum. *L. M. B. C. Memoir*, XX, London (1912).
33. Davaine, C.—Recherches sur la génération des Huitres. *Compt. Rend. Mem. Soc. Biol.* IV, pp. 297-399, pls. i, ii (1852).
34. Davis, J. R. A., and Fleure H. J.—Patella. *L. M. B. C. Memoir*, X, London (1903).
35. Delsman, H. C.—De voortplanting van de mossel. *Rapport schelpdierenvisserij en Schelpdierenteelt Zuiderzee Bijl.* III, pp. 75-88, pls. i-iii (1910).
36. Delsman, H. C.—Entwicklungsgeschichte von *Littorina obtusata*. *Tidschr. ned. Dierk. Ver.* (2) XIII, pp. 170-340, pls. x-xvi, 3 tables (1914). Same as thesis in Dutch (1912).
37. Drew, G. A.—*Yoldia limatula*. *Mem. Biol. Lab. Johns Hopkins Univ.* (3) IV, pp. 1-37, pls. i-v (1899).
38. Drew, G. A.—The Life History of *Nucula delphinodonta*. *Quart. Journ. Microsc. Sci.* XLIV, pp. 313-391, pls. xx-xxv (1901).
39. Drew, G. A.—The Habits, Anatomy and Embryology of the Giant Scallop (*Pecten ten- uicostatus* Mighels). *Univ. Maine Studies* VI, pp. 1-71, pls. i-xvii (1906).
40. Drummond, I. M.—Note on the Development of *Paludina vivipara*, with special refer- ence to the Urinogenital Organs and Theories of Gastropod Torison. *Quart. Journ. Microsc. Sci.* (n. s.) XLVI, pp. 97-143, pls. vii-ix (1902).
41. Eckhardt, E.—Beiträge zur Kenntnis der einheimischen Vitri- nen. *Jenaisch. Zeitschr- Naturwiss.* LI, pp. 213-376, pl. iv (1914).
42. Ehrenbaum, E.—Untersuchungen über die Struktur und Bildung der Schale der in der Kieler Bucht häufig vorkommenden Muscheln. *Zeitschr. wiss. Zool.* LXI, pp. 1-47, pls. i, ii (1884).
43. Erlanger, R. V.—Zur Entwicklung von *Paludina vivipara*. *Morphol. Jahrb.* XVII pp. 338-379, pls. xx-xxiii and pp. 636-680, pls. xxxii, xxxiii (1891).
44. Erlanger, R. V.—Beiträge zur Entwicklungsgeschichte der Gasteropoden. I. Zur Entwicklung von *Bythinia tentaculata*. *Mitt. Zool. Stat. Neapel*, X, pp. 376-407, pls. xxv, xxvi (1892).
45. Field, I. A.—Biology and economic value of the Sea Mussel, *Mytilus edulis*. *Bull. Bur. Fish. Washington*, XXXVIII pp. 127-259 (1923).

46. Flemming, W.—Untersuchungen über Sinnesepithelien der Mollusken. *Archiv Mikrosk. Anat.* VI, pp. 439-471, pls. xxv, xxvi (1870).
47. Flemming, W.—Studien in der Entwicklungsgeschichte der Najaden. *Sitzungsber. kais. Akad. wiss. Wien (Math.-Nat.)* LXXI (Abt. iii), pp. 81-212, pls. i-iv (1875).
48. Flemming, W.—Notiz zur Entwicklungsgeschichte der Najaden. *Zeitschr. wiss. Zool.* XXVI, pp. 355-360 (1876).
49. Flemming, W.—Ueber Binde-substanz und Gefässwandung in Schwellgewebe der Muscheln. *Archiv Mikrosk. Anat.* XIII, pp. 818-867, pls. xlvi-iv (1877).
50. Fleure, H. J.—Zur Anatomie und Phylogenie von *Haliotis*. *Jenaisch. Zeitschr. Naturwiss.* XXXIX, pp. 245-322, pls. ix-xiv (1904).
51. Flössner, W.—Die Schalenstruktur von *Helix pomatia*. *Zeitschr. wiss. Zool.* CXIII, pp. 546-577 (1915).
52. Fol, H.—Note sur le développement des Mollusques Ptéropodes et Cephalopodes. *Arch. Zool. exp. Gén.* (1) III, pp. xxiii-xlv, pl. xviii, figs. 6-16 (1874).
53. Fol, H.—Sur le développement des Ptéropodes. *Compt. Rend. Acad. Sci. Paris*, LXXX, pp. 196-199 (1875).
54. Fol, H.—Sur le développement des Hétéropodes. *Compt. Rend. Acad. Sci. Paris*, LXXXI, pp. 472-474 (1875).
55. Fol, H.—Sur le développement des Gastéropodes pulmonés. *Compt. Rend. Acad. Sci. Paris*, LXXXI, p. 523 (1875).
56. Fol, H.—Etudes sur le développement des Mollusques.
 (a) Sur le développement des Pteropodes. *Arch. Zool. exp. Gén.* (1) IV, pp. 1-214, pls. i-x (1875).
 (b) Sur le développement embryonnaire et larvaire des Hétéropodes. *Op. cit.* (1) V, pp. 105-158, pls. i-iv (1876).
 (c) Sur le développement des Gastéropodes pulmonés. *Op. cit.* (1) VIII, pp. 103-232, pls. ix-xviii (1879).
57. Frank, E. J.—Beiträge zur Anatomie der Trochiden (*Monodonta turbinata*, *Gibbula cinerea*, *Photinula taeniata*). *Jenaisch. Zeitschr. Naturwiss.* LI, pp. 377-486, pl. v (1914).
58. Fullarton, J. H.—On the Development of the Common Scallop (*Pecten opercularis*). *Ann. Rept. Fish. Board Scotland* for 1899, VIII, pp. 290-299, pls. v-viii (1890).
59. Ganin, M.—Beitrag zur Lehre von den Blättern embryonalen bei den Mollusken. *Warschauer Universitätsberichte*, I, pp. 115-171 (1873) in Russian; extract in *Jahresber. Fortschritte Anat. Physiol.* I, pp. 355-360 (1873) by Hoyer.
60. Garnault, P.—Recherches anatomiques et histologiques sur le *Cyclostoma elegans*. Thesis pp. 1-152, Bordeaux (1887), also in *Act. Soc. Linn. Bordeaux* XLI (1887).
61. Geganbaur, C.—Beiträge zur Entwicklungsgeschichte der Landgasteropoden. *Zeitschr. wiss. Zool.* III, pp. 371-411, pls. x-xii (1852).
62. Georgevitch, P.²—Zur Entwicklungsgeschichte von *Aplysia depilans*, L. *Anat. Anz.* XVIII, pp. 145-174 (1900).

63. Goette, A.—Bemerkungen über die Embryonalentwicklung der Anodonta. *Zeitschr. wiss. Zool.* LII, pp. 158-168 (1891).
64. Gray, J. E.—Some observations on the Economy of Molluscos Animals, and on the structure of their shells. *Phil. Trans. Roy. Soc. London*, CXXIII, pp. 771-819 (1833).
65. Haeckel, W.—Beiträge zur Anatomie der Gattung *Chilina*. *Zool. Jahrb. Suppl.* XIII (Fauna Chilensis), pp. 89-136, pls. vii-xi (1911).
66. Haller, B.—Studien über Docoglosse und Rhipidioglosse Prosobranchier, nebst Bemerkungen über die Phyletischen Beziehungen der Mollusken untereinander. Leipzig (1894).
67. Hatchett, C.—Experiments and Observations on Shell and Bone. *Phil. Trans. Roy. Soc. London*, LXXXIX, pp. 315-334 (1799).
68. Hammarsten, D. D. and Runnström, J.—Zur Embryologie von *Acanthochiton discrepans* Brown. *Zool. Jahrb. (Anat.-Ont.)*, XLVII, pp. 261-318 (1925).
69. Hatschek, B.—Entwicklungsgeschichte von *Teredo*. *Arbeit. Zool. Inst. Wien*, III, pp. 1-44, pls. i-iii (1881).
70. Heath, H.—The development of *Ischnochiton*. *Zool. Jahrb. (Anat.-Ont.)*, XII, pp. 567-656, pls. xxxi-xxxv (1899).
71. Herfs, A.—Über einige drüsig differenzierte Epithelien bei Schnecken. *Zool. Jahrb. (Anat.-Ont.)* XLIII, pp. 557-568 (1922).
72. Herfs, A.—Studien an den Hautdrüsen der Land- und Süßwasser-gastropoden. *Archiv Mikrosk. Anat.* XCVI, pp. 1-39, pls. i, ii (1922).
73. Heschler, K.—Mollusca in Lang's Lehrbuch der vergleichenden Anatomie der Tiere. Jena (1902).
74. Heymons, R.—Zur Entwicklungsgeschichte von *Umbrella mediterranea* Lam. *Zeitschr. wiss. Zool.* LVI, pp. 245-298, pls. xiv-xvi (1893).
75. Holmes, S. J.—The early development of *Planorbis*. *Journ. Morphol.* XVI, pp. 369-458, pls. xvii-xxi (1900).
76. Horst, R.—On the development of the European Oyster. *Quart. Journ. Microsc. Sci.*, XXII, pp. 341-346, pl. xxvii (1882).
77. Horst, R.—De Ontwikkeingsgeschiedenis van de Oester. Embryogenie de l'huitre (*Ostrea edulis*, L.) *Tijdschr. ned. Dierk. Ver.*, Suppl. Deel I, pp. 225-317, pl. vi (1883).
78. Hoyer, H.—Über den Nachweis des Mucins in den Geweben mittelst der Farben methode. *Archiv Mikrosk. Anat.* XXVI, pp. 310-374 (1890).
79. Jacobi, A.—Anatomische Untersuchungen an Malayischen Landschnecken (*Amphidromus chloris* und *Amphidromus interruptus*). *Archiv Naturges. Jahr.* LXI, pt. 1, pp. 293-318, pl. xiv (1895).
80. Jhering, H. von.—Ueber die Entwicklungsgeschichte von *Helix*. *Jenaisch. Zeitschr. Naturwiss.* IX, pp. 299-338, pls. xvii, xviii (1875).
81. Jhering, H. von.—Ueber die Ontogenie von *Cyclas* und die Homologie der Keimblätter bei den Mollusken. *Zeitschr. wiss. Zool.* XXVI, pp. 414-433 (1876).
82. Johnston, G.—An Introduction to Conchology. London (1850).

83. Joyeux-Laffuie, J.—Organisation et développement de l'Oncidie (*Oncidium celticum* Cuv.). *Arch. Zool. exp. Gén.*, XIII, pp. 225-383, pls. xiv-xxii (1882).
84. Kent, W. S.—Notes on the embryology of the Australian Rock Oyster (*Ostrea glomerata*). *Proc. Roy. Soc. Queensland*, VII, pp. 35-40, i pl. (1891).
85. Kleinstuber, H.—Die Anatomie von Trochita, Calyptraea und Janacus. Ein Beitrag zur Kenntnis der Calyptraeiden. *Zool. Jahrb. Suppl.* XIII (Fauna Chilensis), pp. 385-476, pls. xx, xxi (1913).
86. Kofoid, C. A.—Early development of Limax. *Bull. Mus. Comp. Zool. Harvard*, XXVII, pt. ii, pp. 35-118, 8 pls. (1895).
87. Korschelt, E.—Zum Schalenersatz bei Landschnecken. *Archiv Entwicklungs Mechan.* XXX (Tl. ii), pp. 281-290 (1910).
88. Korschelt, E. and Heider, K.—Text-book of the Embryology of Invertebrates. Vol. IV. Translated by M. Bernard and M. F. Woodward. London (1900). German Edition (1893).
89. Kowalevsky, A.—Embryogenie du *Chiton polii* Phil., avec quelques remarques sur le développement des autres Chitons. *Ann. Mus. Hist. Nat. Marseille*, I, No. 5, pp. 1-46, 8 pls. (1883).
90. Kowalevsky, A.—Etude sur l'embryogenie du Dentale. *Op. cit.*, No. 7, pp. 1-54, 8 pls. (1883).
91. Küttler, A.—Die Anatomie von *Oliva peruviana* Lamarck. *Zool. Jahrb. Suppl.* XIII (Fauna Chilensis), pp. 477-544 (1913).
92. Lacaze-Duthiers, H. D.—Mémoire sur le développement des Acéphales lamellibranches (*Ostrea*). *Compt. Rend. Acad. Sci. Paris*, XXXIX, pp. 103-106 (1854).
93. Lacaze-Duthiers, H. D.—Histoire de l'organisation et du développement du Dentale. *Ann. Sci. Nat. (Zool.)* (4) VII, pp. 171-255, pls. v-ix (1857).
94. Lacaze-Duthiers, H. D. & Pruvot, G.—Sur le développement de la *Philine aperta*. *Compt. Rend. Ass. Franc. Sci.* XVI, pp. 643-649 (1888).
95. Lankester, E. R.—Summary of Zoological Observations made at Naples in the winter of 1871-1872. *Ann. Mag. Nat. Hist.*, (4) XI, pp. 85-87 (1873).
96. Lankester, E. R.—Observations on the Development of the pond-snail (*Lymnaeus stagnalis*) and on the early stages of other Mollusca. *Quart. Journ. Microsc. Sci.* (n. s.) XIV, pp. 365-391, pls. xvi, xvii (1874).
97. Lankester, E. R.—Observations on the Development of the Cephalopoda. *Quart. Journ. Microsc. Sci.* (n. s.) XV, pp. 37-47, pls. iv, v (1875).
98. Lankester, E. R.—Contributions to the Developmental History of the Mollusca. *Phil. Trans. Roy. Soc. London*, CLXV, pp. 1-48, pls. i-xii (1875).
99. Lankester, E. R.—On the Invaginate Planula or Diploblastic Phase of *Paludina vivipara*. *Quart. Journ. Microsc. Sci.* (n. s.) XV, pp. 159-166 (1875).
100. Lankester, E. R.—On the coincidence of the Blastopore and Anus in *Paludina vivipara*. *Quart. Journ. Microsc. Sci.* (n. s.) XVI, pp. 377-385, pl. xxv (1876).
101. Lereboullet, A.—Embryologie du Lymnee des étangs, *Lymnaeus stagnalis* (Lam.). *Ann. Sci. Nat. (Zool.)*, (4) XVIII, pp. 87-211, pls. xi-xiv (1862).
102. Leydig, F.—Ueber *Paludina vivipara*. *Zeitschr. wiss. Zool.* II, pp. 125-197, pls. xi-xiii (1850).

103. Leydig, F.—Die Hautdecke und Schale der Gastropoden nebst einer Uebersicht der einheimischen Limaciden. *Archiv Naturges.* Jahrg. XLII, pt. 1, pp. 209-292, pls. ix-xvi (1876).
104. Lillie, F. R.—The Embryology of the Unionidae.—A Study in Cell-Lineage. *Journ. Morphol.* X, pp. 1-100, pls. i-vi (1895).
105. Linden, M. von.—Die Entwicklung der Skulpturen und der Zeichnung bei den Gehäuseschnecken des Meeres. *Zeitschr. wiss. Zool.* LXI, pp. 261-317, pl. xi (1896).
106. Lister, M.—Exercitatio Anatomica altera, in qua maxime agitur de Buccinis Fluvialibus & Marinis. London (1695).
107. Longe, & Mer, E.—De la formation de la coquille dans les Helix. *Compt. Rend. Acad. Sci. Paris*, XC, pp. 882-885 (1880).
108. Macbride, E. W.—The Canadian Oyster. *Canadian Rec. Sci.* IX, pp. 145-156, figs. 1-4 (1904).
109. Macbride, E. W.—Text-Book of Embryology. Vol. I. London (1914).
110. McMurrich, J. P.—A contribution to the Embryology of the Prosobranch Gasteropods. *Studies Biol. Lab. Johns Hopkins Univ.* III, pp. 403-450, pls. xxiv-xxvii (1886).
111. Martens, E. von.—Die Weich- und Schalthiere. Leipzig (1883).
112. Matthes, W.—Beiträge zur Anatomie von *Helix pisana* Müll. *Jenaisch. Zeitschr. Naturwiss.* LIII, pp. 1-50 (1914).
113. Mazzarelli, G.—Monografia della Aplysiidae del Golfo di Napoli (Sistemica, biologia, anatomia, fisiologia et embryologia). *Mem. Soc. Ital. Sci.* IX, No. 4, pp. 1-222, pls. i-xiii (1893).
114. Meckel, H.—Mikrographie einiger Drüsenapparate der niederen Thiere. *Müllers Archiv.* pp. 1-73, pls. i-iii (1846).
115. Meisenheimer, J.—Entwicklungsgeschichte von *Limax maximus*, L.
(a) Furchung und Keimblätterbildung. *Zeitschr. wiss. Zool.* LXII, pp. 415-468, pls. xx-xxiii (1896).
(b) Die Larvenperiode. *Op. cit.* LXIII, pp. 573-664, pls. xxxii-xl (1898).
116. Meisenheimer, J.—Entwicklungsgeschichte von *Dreissensia polymorpha* Pall. *Op. cit.* LXIX, pp. 1-137, pls. i-xiii (1901).
117. Meisenheimer, J.—Die Weinbergschnecke. Leipzig (1912).
118. Moquin-Tandon, A.—Observations sur les appendices du manteau chez plusieurs Gasteropodes fluviatiles. *Journ. Conchyliol.* II, pp. 128-132 (1851).
119. Moquin-Tandon, A.—Histoire Naturelle des Mollusques Terrestres et Fluviatiles de France. Vol. II (1856).
120. Moynier de Villepoix, R.—Note sur l'accroissement de la coquille de l'*Helix aspersa*. *Compt. Rend. Acad. Sci. Paris*, CXIII, pp. 317-319 (1891).
121. Moynier de Villepoix, R.—Recherches sur la formation de la coquille des Mollusques. *Journ. Anat. Physiol.* XXVIII, pp. 461-518, pls. xix, xx, and pp. 582-670, pls. xxii, xxiii (1892).
122. Moynier de Villepoix, R.—De la formation de la coquille dans les Mollusques. *Compt. Rend. Acad. Sci. Paris*, CXX, pp. 512, 513 (1895).

123. Nalepa, A.—Beiträge zur Anatomie der Stylommatophoren. *Sitzungsber. kais. Akad. wiss. Wien (Math.-Naturw. Kl.)*, LXXXVII, pp. 237-302, pls. i-iii (1883).
124. Nalepa, A.—Die Intercellarraume des Epithels und ihre physiologische Bedeutung bei den Pulmonaten. *Op. cit.* LXXXVIII, pp. 1180-1188, 1 pl. (1884).
125. Nathusius-Königsborn, W. von.—Untersuchungen über nicht celluläre Organismen, namentlich Crustaceenpanzer, Molluskenschalen und Eihüllen. Berlin (1877).
126. Otto, H. and Tönniges, C.—Untersuchungen über die Entwicklung von *Paludina vivipara*. *Zeitschr. wiss. Zool.* LXXX, pp. 411-514, pls. xxii-xxvii (1906).
127. Patten, W.—The Embryology of Patella. *Arbeit. Zool. Inst. Wien*, VI, pp. 149-174, pls. i-v (1886).
128. Pelseneer, P.—Mollusca in Ray Lankester's "A Treatise on Zoology." Part V. London (1906).
129. Pelseneer, P.—Recherches sur l'embryologie de Gastropoden. *Mem. Acad. Roy. Belgique*, (2) III, pp. 1-163, pls. i-xxii (1911).
130. Philippi, R. A.—Handbuch der Conchyliologie und Malacologie. Halle (1853).
131. Picard, C.—Histoire des Mollusques terrestres et fluviatiles qui vivent dans le département de la Somme. *Bull. Soc. Linn. Nord France*, I, (1840).
132. Plate, L.—Beiträge zur Anatomie und Systematik der Janelliden (*Janella schauinslandi* n. sp. und *Aneitella berghii* n. sp.) *Zool. Jahrb. (Anat.-Ont.)*, XI, pp. 193-280, pls. xii-xvii (1898).
133. Pruvot, G.—Sur le développement d'un Solénogastre. *Compt. Rend. Acad. Sci. Paris*, CXI, pp. 689-692, figs. i-iii (1890).
134. Rabl, C.—Die Ontogenie der Süßwasser-Pulmonaten. *Jenaisch. Zeitschr. Naturwiss.* IX, pp. 195-240, pls. vii-ix (1875).
135. Rabl, C.—Ueber die Entwicklungsgeschichte der Malermuschel. *Jenaisch. Zeitschr. Naturwiss.* X, pp. 310-393, pls. x-xii (1876).
136. Rabl, C.—Über die Entwicklung der Tellerschnecke. *Morphol. Jahrb.* V, pp. 562-660, pls. xxxii-xxxviii (1879).
137. Reaumur, M. de—De la formation et de l'accroissement des coquilles des animaux tant terrestres qu'aquatiques, soit de mer, soit de rivière. *Hist. Acad. Roy. Sci. Paris*, Année 1709, pp. 364-400, pls. xiv, xv (1711).
138. Reaumur, M. de.—Eclaircissements de quelques difficultes sur la formation et l'acroissement des coquilles. *Op. cit.* Année 1716, pp. 303-311 (1718).
139. Rho, F.—Studiî sullo sviluppo della *Chromodoris elegans*. *Atti. Accad. Napoli*, (2) I, Appendix 3, pp. 1-7, pls. i, ii (1884).
140. Robert, A.—Le Troque (*Trochus turbinatus* Born). Zoologie descriptive des Invertébrés. Vol. II. Paris (1900).
141. Robert, A.—Recherches sur le développement des Troques. *Arch. Zool. exp. Gén.* (iii) X, pp. 269-538, pls. xii-xlii (1902).
142. Rose, G.—Über die heteromorphen Zustände der kohlen sauren Kalkrede. *Abhandlung. Akad. Wissen. Berlin*, pp. 63-111, pls. i-iii (1858).
143. Salensky, W.—Beiträge zur Entwicklung der Prosobranchier. *Zeitschr. wiss. Zool.* XXII, pp. 428-454, pls. xxxv-xxxviii (1872).

144. Salensky, W.—Bemerkungen über Haeckel's, Gastraea-Theorie (Ostrea). *Archiv Naturges.* Jahrg. XL, pt. I, pp. 137-174, pl. v (1874).
145. Salensky, W.—Études sur le développement des Vermets. *Archiv. Biol.* VI, pp. 655-759, pls. xxv-xxxii (1887).
146. Sarasin, P. B.—Entwicklungsgeschichte von *Bithynia tentaculata*. Würzburg Inaug. Diss., Wiesbaden (1882), and in *Arb. Zool. Inst. Würzburg*, VI, pp. 1-68, pls. i-vii (1883).
147. Scheidig, K.—Zur Anatomie von *Crucibulum ferrugineum*. *Zool. Jahrb.* Supplement XIII (Fauna Chilensis), pp. 137-174, pls. xii-xv (1913).
148. Schierholz, C.—Ueber Entwicklungsgeschichte der Teich- und Fluss-Muschel. pp. 1-71, 3 pls. Berlin (1878).
149. Schierholz, C.—Ueber Entwicklung der Unioniden. *Denkschr. kais. Akad. wiss. Wien (Math.-Naturw. Kl.)*, LV, pp. 183-214, pls. i-iv (1888).
150. Schmidt, F.—Beiträge zur Kenntnis der Entwicklungsgeschichte der Stylommatophoren. *Zool. Jahrb. (Anat.-Ont.)*, VIII, pp. 318-341 (1895).
151. Schumann, W.—Über die Anatomie und die systematische Stellung von *Gadinia peruviana* Sowerby und *Gadinia garnoti* Payraudeau. *Zool. Jahrb.* Supplement XIII (Fauna Chilensis), pp. 1-88, pls. i-vi (1911).
152. Semper, C.—Beiträge zur Anatomie und Physiologie der Pulmonaten. *Zeitschr. wiss. Zool.* VIII, pp. 340-399, pls. xvi, xvii (1857).
153. Semper, C.—Entwicklungsgeschichte der *Ampullaria polita*. *Naturk. Verhandl. Utrechts Genootsch.*, I (liv. 2), pp. 1-20, pls. i-iv (1862).
154. Sewell, R. B. S.—The Banded Pond-Snail of India (*Vivipara bengalensis*). I. Anatomical. *Rec. Ind. Mus.* XXII, pp. 217-242 (1921).
155. Siebold, C. T. von.—Lehrbuch der vergleichenden Anatomie der Wirbellosen Thiere. Vol. 1. Berlin (1848).
156. Simroth, H.—Die Sinneswerkzeuge der einheimischen Weichthiere. *Zeitschr. wiss. Zool.* XXVI, pp. 227-349, pls. xv-xxi (1876).
157. Simroth, H.—Die Gastropoden der Plankton-Expedition. *Ergeb. Plankton-Expedt.* II, *fd*, pp. 1-200, pls. i-xxii (1895).
158. Simroth, H.—Die Acephalen der Plankton-Expedition. *id.* II, *fe*, pp. 1-44, pls. i-iii and charts (1896).
159. Simroth, H.—Bronn's Thier-Reich. Mollusca: Gastropoda Prosobranchia. pt. ii, Vol. III, (1896-1907).
160. Speyer, O. W. C.—Zootomie der *Paludina vivipara*. Marburg (1855).
161. Stafford, J.—The Canadian Oyster. Its Development, Environment and Culture. Ottawa (1913).
162. Stempel, W.—Ueber die Bildungsweise und das Wachstum der Muschel- und Schnecken-schalen. *Biol. Centralbl.* XX, pp. 596-606, 637-644, 665-680, 698-703, 731-741 (1900).
163. Stepanoff, P.—Über die Geschlechtsorgane und die Entwicklung von *Cyclas*. *Archiv Naturges.* Jahrg. XXXI (1), pp. 1-32, pls. i, ii (1865).
164. Swammerdam, J.—Biblia Naturae (1737, 1738). English translation by T. Flloyd, revised and improved by John Hill. London (1758).

165. Techow, G.—Zur Kenntnis der Schalenregeneration bei den Gasteropoden. *Archiv Entwicklungs. Mechan.* XXXI, pp. 258-288, pls. ix, x (1910).
166. Techow, G.—Zur Regeneration des Weichkörpers bei den Gastropoden. *id.*, pp. 353-386, pls. xv-xviii (1910).
167. Thiele, J. Beiträge zur Kenntnis der Mollusken.
 II. Über die Molluskenschale. *Zeitschr. wiss. Zool.* LV, pp. 220-251, pl. xi (1892).
 III. Über die Hautdrüsen und ihre Derivate. *Op. cit.* LXII, pp. 632-670, pls. xxxi, xxxii (1897).
168. Tönniges, C.—Die Bildung des Mesoderms bei *Paludina vivipara*. *Zeitschr. wiss. Zool.* LXI, pp. 541-605, pls. xxv, xxvi (1896).
169. Tullberg, T.—Studien über den Bau und das Wachstum des Hümmerpanzers und der Molluskenschalen. *Kongl. Svensk. Vetensk. Akad. Handlingar*, XIX (n. f.), No. 3, pp. 1-57, pls. i-xii (1882).
170. Viguier, C.—Contribution à l'étude du développement de la *Tethys fimbriata*. *Arch. Zool. exp. Gén.* (3) VI, pp. 37-62, pls. vii-ix (1898).
171. Warneck, N. A.—Ueber die Bildung und Entwicklung des Embryos bei Gasteropoden. *Bull. Soc. Nat. Moscou*, XXIII, pp. 90-194, pls. ii-v (1850).
172. Weber, L.—Die Mantel- und Geschlechtsorgane von *Cyclophorus ceylanicus* (Sowerby). *Jenaisch. Zeitschr. Naturwiss.* LX, pp. 397-437, pls. xxiii, xxiv (1924).
173. Wierzejski, A.—Embryologie von *Physa fontinalis* L. *Zeitschr. wiss. Zool.* LXXXIII, pp. 502-706, pls. xviii-xxvii (1905).
174. Wille, J.—Untersuchungen über den anatomischen Bau der Lungenschnecke *Stenogyra decollata*. *Jenaisch. Zeitschr. Naturwiss.* LIII, pp. 717-804, pls. ix, x (1915).
175. Wilson, E. B.—Experimental Studies in Germinal Localization. II. Experiments on the Cleavage-Mosaic in *Patella* and *Dentalium*. *Journ. Exper. Zool.* I, pp. 197-268 (1904).
176. Wilson, J.—On the Development of the Common Mussel (*Mytilus edulis* L.). *Ann. Rept. Fish. Board Scotland*, V. for 1886, pp. 247-256, pls. xii-xiv (1887).
177. Wolfson, W.—Die embryonale Entwicklung des *Lymnaeus stagnalis*. *Bull. Acad. Imp. Sci. St. Petersbourg*, XXVI, pp. 79-98, figs. 1-10 (1880).
178. Ziegler, H. E.—Die Entwicklung von *Cyclas cornea* Lam. (*Sphaerium corneum* L.). *Zeitschr. wiss. Zool.* XLI, pp. 524-569, pls. xxvii-xxviii (1885).
179. Zill, R.—Die subepithelialen Hautdrüsen von *Helix pomatia* und einigen anderen Landgähäuseschnecken. *Zeitschr. Anat. Entwicklungsges.* LXXI, pp. 1-40 (1924).

10. REFERENCE LETTERING.

The following reference lettering is the same for all the plates. *B. W.*, Body-whorl of the shell; *C. C.*, Calcareous particles in the connective tissue; *C. E.*, Ciliated epithelium; *C. S.*, Calcosphaerites; *C. T.*, Connective tissue; *G. C.*, Gland cells of the supramarginal ridge; *G. M. P.*, Groove of the marginal processes of the mantle as seen in sections; *G. P.*, Groove of the marginal processes; *H.*, Hypostracum; *M.*, Muscle fibres; *M.E.*, Epithelial

covering of the dorsal surface of the mantle ; *M. P.*, Marginal process of the mantle ; *N.*, Nucleus ; *O.*, Ostracum ; *P.*, Periostracum ; *Pi.*, Pigment granules ; *P. S.*, The first periostracal elements of the shell ; *R.*, The longitudinal spiral ridges of the mantle surface ; *S.G.*, Supramarginal groove ; *S. P.*, Secondary processes of the mantle margin ; *S.R.*, Supramarginal ridge ; *X.*, The undifferentiated epithelial region of the supramarginal ridge ; 1—3, The three primary processes of the mantle margin.

EXPLANATION OF PLATE XX.

- Fig. 1. *Viviparus bengalensis* (Lam.), from Calcutta. A part of the mantle margin of a full-grown individual from the right half, seen as a transparent object. It shows the well developed primary process and the remains of a number of secondary marginal processes. $\times 5$.
- Fig. 2. *V. viviparus* (Linn.), from near Manchester. A vertical section of the mantle margin of a young embryo showing the supramarginal ridge and the groove. $\times 300$.
- Fig. 3. *V. viviparus* (Linn.). The region of the supramarginal ridge and groove as seen in a vertical section of an adult. It shows the structure of the gland cells of the groove, the more highly modified gland cells of the supramarginal ridge, the calcareous globules lying near the bases of the gland cells in the connective tissue and the arrangement of the muscle fibres in the connective tissue. $\times 240$.
- Fig. 4. *V. bengalensis* (Lam.). A vertical longitudinal section of the margin of a half-grown individual parallel to the margin showing the grooves of the marginal processes as seen in a transverse section. $\times 50$.
- Fig. 5. *V. viviparus* (Linn.). The gland cells of the supramarginal ridge as seen in a vertical longitudinal section. Some of the less differentiated cells on the sides of the gland cells are also shown; they apparently later replace the degenerated cells. $\times 550$.
- Fig. 6. *V. fasciatus* (Müll.), from near Manchester. A vertical section of the corresponding region of the mantle margin of an embryo to that in figure 3, to show the arrangement of the undifferentiated cells of the embryonic supramarginal ridge which later develop into the gland cells of the region. $\times 240$.
- Fig. 7. *V. fasciatus* (Müll.). A vertical section of the mantle margin of the adult in the region corresponding to that in figure 2, to show the structure of the gland cells and the arrangement of the muscle fibres. $\times 240$.
- Fig. 8. *V. delavayana* (Heude), from Saifu, China. A vertical section of the mantle margin of an adult in the region corresponding to that in figure 3, and showing the supramarginal ridge and groove, the calcareous globules and the connective tissue. $\times 240$.
- Fig. 9. *Dactylochlamys oxytropis* (Benson), from Loktak Lake, Manipur. A vertical section of the mantle margin of an embryo showing the more extensive region of the gland cells of the supramarginal ridge than is the case with *Viviparus s. s.*; the basal parts of some of the cells from the neighbouring areas are arranged in separate masses. $\times 300$.
- Fig. 10. *D. oxytropis* (Benson). A vertical section of the mantle margin of the adult to illustrate the structure of the area corresponding to that shown in figure 3. $\times 20$.
- Fig. 11. *D. lanaonis* (Bartsch) var. *theta* (Bartsch), from Lake Lanao, Philippin. The dorsal epithelial covering of the mantle surface from the region of the colour-band showing the pigment granules in the upper third to half of the cells. $\times 250$.
- Fig. 12. *D. lanaonis* (Bartsch) var. *theta* (Bartsch). Two of the cells of the dorsal epithelial covering of the mantle more highly magnified, and showing the passage of the pigment granules from the connective tissue into one of the cells. $\times ca. 750$.
- Fig. 13. *D. lanaonis* (Bartsch) var. *theta* (Bartsch). A chromatophore with its nucleus containing only a few feebly staining chromatin particles and the plasma with numerous pigment granules. $\times ca. 750$.
- Fig. 14. *Taia ultha* Annandale, from Inlé Lake, S. Shan States. A vertical section of the mantle margin of an adult in the region corresponding to that shown in figure 3. $\times 240$.