

THE LEECHES OF INDIA —A HANDBOOK

By

MAHESH CHANDRA

Zoological Survey of India

High Altitude Zoology Field Station,

SOLAN (H.P.)—173 212



Edited by the Director, Zoological Survey of India, Calcutta
1991

© Copyright Government of India, 1991

Published : June, 1991

PRICE : Inland : Rs. 190·00

Foreign : £ 9·00 or \$ 16·00

PRINTED AT THE BANI PRESS, 16, HEMENDRA SEN STREET,
CALCUTTA-700 006, AND PUBLISHED BY THE DIRECTOR,
ZOOLOGICAL SURVEY OF INDIA, CALCUTTA-700 020,

AUTHOR'S PREFACE

The literature on Indian leech up to date, has been scattered. First comprehensive work on Indian leech fauna was published by Harding and Moore (1927). The subsequent literature on the fauna is so scattered that it becomes very difficult for the researchers to keep themselves abreast of the latest position in the group. It was felt that all these accounts should be brought together at one place which induced me to bring out the present handbook (Having worked for more than twenty five years on the group). I have been able to procure the subsequent literature from the Indian workers as well as foreign workers. The positive and useful help and encouragement from my colleagues, both in the Zoological Survey of India, and outside also was instrumental in my undertaking this task which is now completed.

Dr. P. J. Sanjeeva Raj and Dr. S. C. Baugh have been extremely generous in providing the much needed information on the leech fauna. For certain revisions in systematics and classification a great help has been taken from the published work of Prof. A. Soos. I offer my sincere thanks to each of them. Dr. B. K. Tikader, was the first to moot such an idea for publishing this Handbook. Both the Officer-in-Charge and Dr. J. M. Julka of the High Altitude Zoology Field Station, Zoological Survey of India, Solan, have been very kind in providing the necessary facilities and guidance throughout the course of this work, I am specially thankful to them.

I fervently hope that this publication will be helpful to workers in the group and generate further interest in leech fauna of our country and will stimulate more research investigations on Indian Hirudinea.

CONTENTS

	PAGE
AUTHOR'S PREFACE	
INTRODUCTION	... 1
ARRANGEMENT	... 2
METHODS OF COLLECTION, PRESERVATION AND STUDY	3
GENERAL MORPHOLOGY AND ANATOMY	... 4
IMPORTANT COUNTS	... 5
HISTORICAL REVIEW	... 6
SYSTEMATIC ACCOUNT	... 8
BIBLIOGRAPHY	... 110
INDEX TO SCIENTIFIC NAMES	... 116

INTRODUCTION

The leeches belong to the class Hirudinea of the phylum Annelida. It is characterised by the segmented coelomates ; protostomes ; primarily fresh-water and terrestrial. The class Hirudinea is subdivided into two orders namely Rhynchobdellae and Arhynchobdellae.

The order Rhynchobdellae comprises those leeches which have a protrusible proboscis by means of which they suck the blood and juices of their prey. The species belonging to this order are mainly freshwater and a few marine forms. Except a few marine forms they are generally, from 6mm to 20mm in length and thus they may escape the attention of ordinary observer.

The order Arhynchobdellae include those species of leeches which are without a proboscis. They are called jawed leeches. In this order the leeches have reached their maximum specialization expression. These leeches are adapted to a sanguivorous or a predaceous habit, they are freshwater or terrestrial but never truly marine as far as known. Their length varies from about 10 cm-25 cm to 40 cm.

The leeches are of two types, i. e. venomous and non-venomous. Only the non-venomous leeches should be applied for blood sucking. The non-venomous leeches are found in sweet scented waters, live on non-poisonous weeds and suck blood from the affected part of human organisms without causing any discomfort.

The venomous leeches are thick about the middle, elongated of slow locomotion, look fatigued, capable of sucking only a small quantity of blood, should not be taken as belonging to the commendable type. They have their origin in the decomposed urine and faecal matters of toads and venomous fishes in pools of stagnant and turbid water and the common zoophytes which live in clear waters. The bite of venomous leeches produce considerable swelling and intense itching at the spot. The bite gives rise to fever, burning, drowsiness, delirium, and ultimately unconsciousness. The remedy lies in the administration of anti-toxic medicines,

The native treatment for removing the leech is by transfixing it with a sharp thorn or dislodge it with the so called nicotine which accumulates in tobacco-pipes. The other effective methods for removing the leeches are—
1. when accessible, seizing the leech with suitable forceps,
2. paralysing the leech with cocain by spraying on it, if it is not sufficient then apply cotton-wool dipped in 30% cocain.

In Anglo-Saxon time the leeches have been used for blood sucking and for the medical man. In nineteenth century the leeches have been in much more use than the public were aware. In England and France there were farms for the artificial cultivation of leeches. There is no doubt that the medicinal leech is one of the most beautiful of animals. Many of its cousins are uniforms and dull in colour, it has been used as decorative pieces also.

ARRANGEMENT

This Handbook includes all the known marine, fresh-water and terrestrial leeches found within the political limits of India. The leeches found in Pakistan, Bangla Desh, Burma, Sri Lanka, Nepal and Bhutan has not been included in this book.

The present account deals with 51 species and eight subspecies so far known within the political boundaries of India. These species fall under 5 families and 25 genera.

Uniform pattern in citation and arrangement has been followed. Salient features of all taxa up to generic level given. Details in respect of species are provided more elaborately. Dichotomous keys are given for orders, families, genera and species. All the species that are known till 1984, are listed under each genus with their geographical distribution.

The bibliography contains all pertinent literature of leeches dealt with in this book. An index to the scientific names found in the book is appended last,

METHODS OF COLLECTION, PRESERVATION AND STUDY

The leeches are generally collected from the under surface of the submerged articles from tanks, pools, lakes, hill streams and rivers, in which they keep themselves attached. They can also be collected by dredging the bottom of tanks, pools and lakes with the help of water net. They can also be found as ectoparasites on crustaceans, molluscs, amphibians, reptiles and fishes. The leeches can also be looked from deep and dampy forests, wet and marshy places and paddy fields.

The preservation of leeches (Hirudinea) is much more difficult in comparison to those of oligochaeta and polychaeta. Leeches lack the many salient features (external) of the former and are much more difficult to dissect than the latter. The main difficulty arises from their great capacity for contraction and extension.

The leeches collected are placed in a petridish with small quantity of water and narcotised with the help of carbondioxide, chloroform fumes, weak nicotine, magnesium sulphate or alcohol added gradually, in which leeches usually die extended. When they no longer respond to pinching of needles, and before maceration begins, they should be rapidly passed between the fingers to remove the surplus mucous. The specimens are straightened and placed extended side by side in a flat dish, Then the fixing fluid 2% formaldehyde or 50% alcohol is poured on the specimens covered with a thin layer of cotton wool to prevent the displacement and floating of specimens. After they have been fully stiffened they should be kept in rectified spirit or 4-5% formaldehyde. The specimens should be placed in tubes of sufficient length and diameter to avoid overcrowding and distortion.

The proper and satisfactory study of leeches can be made with living or recently preserved specimens, because these alone exhibit the true colours, normal proportions etc. The details of annulation, surface sculpture, and most of the internal anatomy, can be studied satisfactorily on properly hardened specimens. The entire anatomy of small leeches

can be determined by putting the living specimens under pressure and studying them under microscope. The smaller and transparent specimens can be stained and studied.

GENERAL MORPHOLOGY AND ANATOMY

Characters of systematic importance

External Characters : The body of a leech is always composed of thirty four segments or somites. Each somite contains a ganglion which is a fundamental test for a somite. Hence the central nervous system contains thirty four ganglia. Of these, the circumpharyngeal ganglionic mass contains six and the posterior ganglionic mass contains seven fused ganglia, and twenty-one free single ganglia lie in the ventral chain between them.

In leeches the number of rings or *annuli* exceeds the number of somites. The majority of somites having equal number of rings are known as complete somite. In rhynchobdellid leeches the somite may contain from two to fourteen rings. The rings in somite towards the extremities become progressively smaller and at the anterior extremity one or more somites may be represented only by a single ring.

The sensitive body of a leech is covered by minute sense-organs called sensillae. The sensillae lies on the sensory ring of the somite overlying the ganglion of ventral chain and appear in strict series in definite longitudinal rows of lines.

From one to four pairs of eyes may be present in the Rhynchobdellae, its number and arrangement are of great diagnostic value. In Arhynchobdellae it is five or more than five pairs, as in the case of family Erpobdellidae.

In addition to these characters, the colour markings, form of the body and its suckers, the position of the genital apertures in the ventral median line and the mouth opening in the anterior sucker are taxonomically of great importance.

Digestive System : The digestive system consists of oral chamber, buccal sinus (proboscis), pharynx, oesophagus, stomach (crop), intestine, rectum, and anus. Oral chamber is simple, buccal sinus may or may not be well developed with protrusible proboscis in the order Rhynchobdellae.

The jaws are present in buccal sinus in the Order Arhynchobdellae, pharynx fixed or movable, oesophagus present anterior to the stomach and may be long or short, stomach may be provided with single or paired caeca or having many chambers. Intestine small in the form of longitudinal tube without caeca, sometimes indistinguishable from the rectum ; rectum small, ending at the anus.

Reproductive System : In the reproductive system the male organs consist of testes, vas efferens, vas deferens, sperm reservoir and bursa. The testes are disposed off segmentally or intersegmentally, commonly 9 to 10 pairs, rarely 6 to 12 pairs, It may be simple or minutely subdivided into numerous small ovoid bodies. Each testes or testicular sac communicates by a short vas efferens with vas deferens of its own side. Sperm reservoir may be massive, reduced or absent. The ejaculatory duct may be a simple tube differentiated into an enlarged fusiform region and a narrow duct like portion. The bursa small, eversible present at the terminal part or rudimentary.

The female reproductive system consists of more or less elongated or small globular ovisacs which contain true ovaries and forms common oviduct opening to the exterior by the female pore. The oviduct may be small or enlarged to form an ovarian vesicle before the formation of common oviduct. The common oviduct empties into the vagina at the internal blind end.

IMPORTANT COUNTS

The leeches have the noteworthy characteristic in the numerical constancy of their constituent segments, which are variously named. The important count in leeches consists

of the total number of somites or segments, which is I to XXXIV and remain constant in the group irrespective of age. They are designated by the Roman numerals and are grouped into five or six well marked regions. The head or cephalic region of somites I to VI ; pre-clitellar region of VII to IX ; the middle body region of X to XXIV ; further subdivided into clitellar or genital region of somites (X to XIII) and post clitellar region (somites XIV to XXIV) ; the anal region of XXV to XXVII ; and the caudal region or sucker of somites XXVIII to XXXIV.

In leeches the number of rings or annuli exceeds the number of somites, and throughout the greater part of its length these rings resolve themselves into a series of regularly recurring groups, corresponding to the successive somites of the body. Each of these similar groups containing an equal number of rings is termed in leech nomenclature a *complete somite*. Towards the ends of the body the number of rings in a group becomes progressively smaller, forming what are regarded as reduced or *incomplete somites*. The anterior extremity may be represented by one or more somites of a single ring. The counting of total number of rings in an individual is an important external morphological character for the determination of species.

HISTORICAL REVIEW

Leeches are so widely abundant in warmer and temperate areas of the world, and they come in such close contact of humanity, that it is not surprising to find their description in the both ancient and modern literature of the leading nations of the world.

Although in Egyptian literature there is no word for leech, in Sinhalese (Sri Lankan literature) it appears to have no derivative of *jaluka-juko* family. In Chinese literature the references to leech are very scanty and is known as Ch'i, and in Syriac there are a few references to leeches as *iligitu* corresponding to *alegetha* (leech).

But in Sanskrit literature the leeches have been referred

oftenly. The most common names mentioned therein are "*Raktapa*" (blood-drinker), "*Jalauka*" (water-dweller) and "*Jala-Sarpani*" (water-glider). In Hindi and other north Indian languages it is known as "*Jonk*" (leech). The word "*Jalauka*" first appears in the Holy book of "Mahabharata".

The only reference in Bible seems to be in proverbs. The Talmud contains a warning against drinking water from river pools "for there is most dangerous leech" known as *Limnatis nilotica*, about 10mm in length. It was first described by Savigny (1820). *Limnatis nilotica*, unlike *Hirudo medicinalis* the medicinal leech, is unable to bite through the outer integument of man and is only able to feed when it has access to the softer parts of the mouth or of the pharynx or larynx. The effect on the human being is to produce constant small haemorrhages from the mouth or nose. Turbner (1901) in the Encyclopaedia of Indo-Aryan Research, has given an account on bleeding with the help of leeches which are especially suitable for princess, wealthy people, children, nervous and delicate people and women. For this purpose only non-poisonous species should be employed.

The earliest comprehensive work on Indian leeches was done by Harding and Moore (1927); in which they dealt with 51 species and subspecies of leeches from the Indian subcontinent. Since then a considerable number of additions have been made to the leech fauna of the Indian region. The total number of known species has also greatly increased due to the valuable work of researchers like Baugh (1960 a&b), Bhatia (1930, 1934 & 1939), Chelladurai (1934), and Sanjeeva Raj (1951, 1954, 1959 & 1974). The revisionary work of Soos (1965 through 1970) on the world leech fauna has led to some changes in the specific and subspecific names which are detailed by the present author elsewhere (Chandra, 1983).

However the leeches have been undoubtedly used throughout the world as remedies for the throat and inflammatory swellings on account of their property of sucking blood, in excess, in any person,

SYSTEMATIC ACCOUNT

Class HIRUDINEA

Order I. *Rhynchobdellae*Family 1. *Piscicolidae*

- Genus 1. *Piscicola* de Blainville
- Genus 2. *Pterobdella* Kaburaki
- Genus 3. *Pontobdellina* Harding
- Genus 4. *Zeylanicobdella* De Silva
- Genus 5. *Ozobranchus* De Quatrefagus
- Genus 6. *Branchellion* Savigny

Family 2. *Glossiphonidae*

- Genus 7. *Glossiphonia* Johnson
- Genus 8. *Batracobdella* Viguer
- Genus 9. *Helobdella* Blanchard
- Genus 10. *Placobdella* Blanchard
- Genus 11. *Theromyzon* Philippi
- Genus 12. *Hemiclepsis* Vejdovsky
- Genus 13. *Paraclepsis* Harding

Order II. *Arhynchobdellae*Family 3. *Erpobdellidae*

- Genus 14. *Erpobdella* de Blainville
- Genus 15. *Barbronia* Johanson
- Genus 16. *Nematobdella* Kaburaki
- Genus 17. *Herpobdelloidea* Kaburaki
- Genus 18. *Foraminobdella* Kaburaki

Family 4. *Hirudidae*

- Genus 19. *Myxobdella* Oka
- Genus 20. *Whitmania* Blanchard
- Genus 21. *Dinobdella* Moore
- Genus 22. *Hirudo* Linnaeus
- Genus 23. *Haemopsis* Savigny
- Genus 24. *Poecilobdella* Blanchard

Family 5. *Haemadipsidae*

- Genus 25. *Haemadipsa* Tennant

SYSTEMATIC ACCOUNT

Phylum : ANNELIDA

Class : HIRUDINEA

Diagnostic Characters of : Order RHYNCHOBDELLAE

Presence of protrusible proboscis, without jaws. It contains no terrestrial or carnivorous forms. Strictly parasitic and consists of freshwater and marine species without exception. Generally of small size, only a few are large but never reach the formidable proportions attained by certain predaceous Arhynchobdellae, size 6mm to 20mm.

In this order two families and thirteen genera are dealt with.

Diagnostic Characters of : Family PISCICOLIDAE

Body cylindrical or flattened, often divided into two distinct anterior and posterior regions and sometimes with paired lateral branchiae and pulsating vesicles. The anterior sucker is generally, and the posterior sucker is always, a permanent cupuliform or discoid organ distinct from the body. Marine and freshwater forms, largely parasitic upon fish.

Key to the genera and species of the family PISCICOLIDAE

1. Eyes absent ; lateral branchiae or pulsating vesicles absent. ... 2
Eyes present ; lateral branchiae or pulsating vesicles present. ... 4
2. Body divided into distinct regions. ... 3
Body not divided into distinct regions. ... *Piscicola caeca*
3. Body divided into three distinct regions of which anterior two are provided with fin-like processes ; tubercles absent. ... *Pterobdella amara*
Body divided into two distinct regions ; lateral fin-like processes absent ; tubercles present. ... *Pontobdellina macrothela*
4. Eyes one pair. ... 5
Eyes 2 pairs. ... *Piscicola olivacea*
5. Lateral branchiae present ; pulsating vesicles absent. ... 6

Lateral branchiae absent ; pulsating vesicles present.	...	<i>Zeylanicobdella arugamensis</i>
6. Posterior region with less than eleven pairs of branchiae.	...	7
Posterior region with eleven or more than eleven pairs of branchiae.	...	8
7. 5 pairs of branchiae.	...	<i>Ozobranchus margoi</i>
7 pairs of branchiae.	...	<i>Ozobranchus branchiatus</i>
8. Branchiae more than 20 pairs.	...	<i>Branchellion plicobranchus</i>
Branchiae 20 or less than 20 pairs.	...	9
9. 11 pairs of branchiae.	...	<i>Ozobranchus shipleyi</i>
20 pairs of branchiae.	...	<i>Ozobranchus polybranchus</i>

Genus : Branchellion Savigny

1822. *Branchellion*, Savigny, "Systeme des Annelides", in description de 1 Egypte, Paris.

The genus *Branchellion* is a marine form and parasitic mainly on fishes. It is characterised by the presence of Branchiae. The body is divided into two parts, neck and abdomen. Presence of more than twenty pairs of branchiae, pulsating vesicles and caudal papillae are the main features of the genus.

Branchellion plicobranchus Sanjeeva Raj

1954. *Branchellion plicobranchus* Sanjeeva Raj, *Rec. Indian Mus.*, 52 : 249-256. (Type-locality : Assumption Island, Bay of Bengal (Tamil Nadu) ; Type-Deposited : Z.S.I.).

1983. *Branchellion plicobranchus*, Chandra, *Rec. zool. Surv. India*, 80 : 272.

Diagnostic characters : The body is divisible into a narrow anterior neck and a posterior broad branchiate abdomen terminating in a larger posterior sucker. The abdomen is distinctly annulated, more conspicuously so on ventral side. Anterior sucker is smaller than the posterior sucker, is oval in shape. Eleven pairs of pulsating vesicles are noticeable. The characteristic caudal papillae are present in the posterior sucker. Total number of annuli 59. Thirty

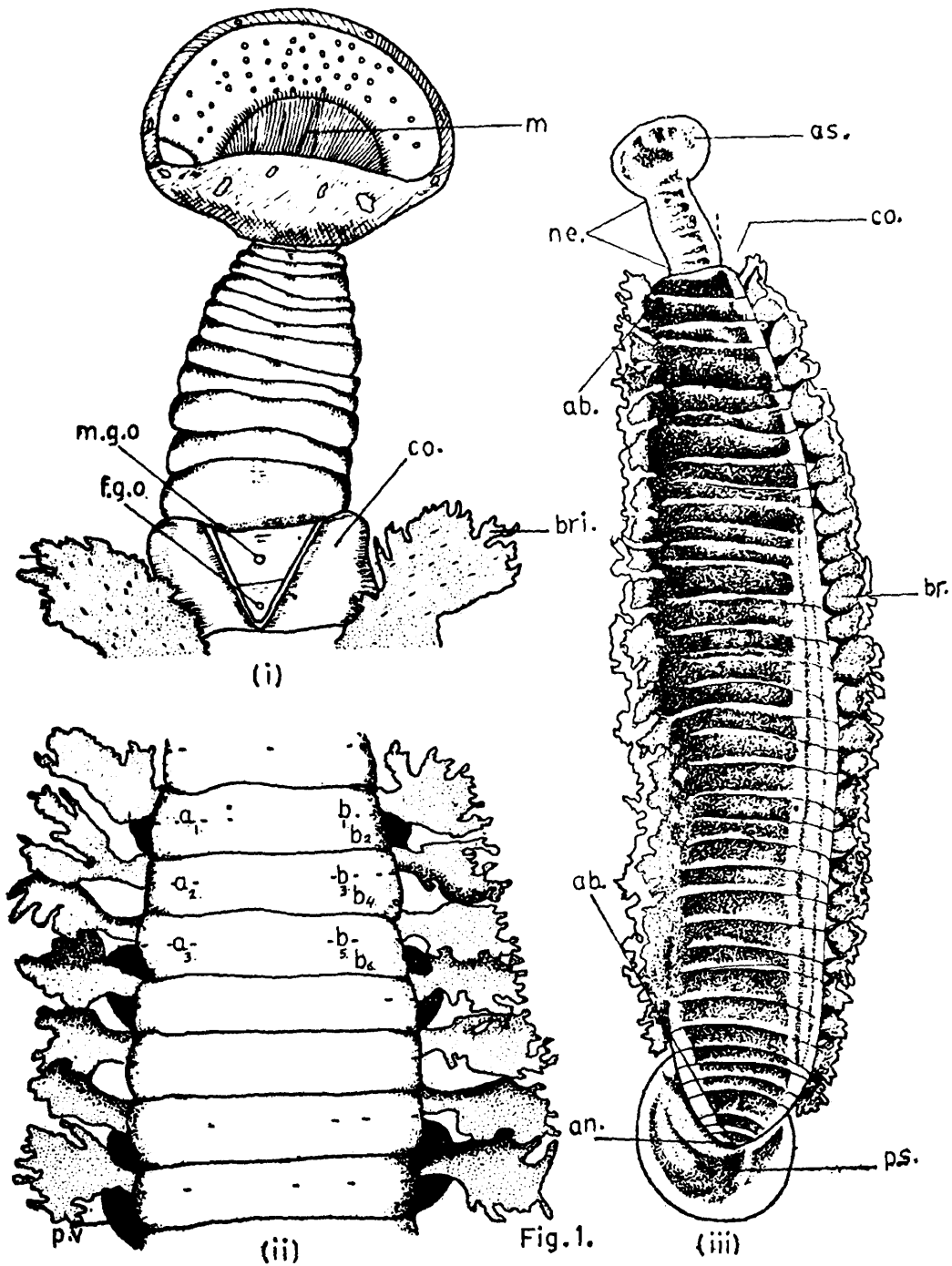

Fig. 1. *Branchellion plicobranchus* (Sanjeeva Raj, 1954). (i) Ventral view of anterior region, (ii) Branchiae and pulsating vesicles of two adjacent segments enlarged (Diagrammatic). *a.1-a.3*, primary annuli ; *ab.*, abdomen ; *an.*, anus ; *as.*, anterior sucker ; *b.1-b.6*, secondary annuli ; *br.*, branchia ; *br. 1*, Ist branchia ; *co.*, collar (preputial fold) ; *f.g.o.*, female genital opening ; *m.*, mouth ; *m.g.o.*, male genital opening ; *ne.*, neck ; *p.s.*, posterior sucker ; *p.v.*, pulsating vesicle. (After Sanjeeva Raj).

three pairs of branchiae in the abdominal region. The branchiae are frilled at their extremity. (Fig.1).

Distribution : India : Assumption Island, Bay of Bengal and fish market of Madras (Tamil Nadu); Vizagapatam (Andhra Pradesh); Quillon (Kerala) and Bomday (Maharashtra).

Field observation : The species is mainly parasitic on marine fishes.

Genus : Ozobranchus de Quatrefagus

1852. *Ozobranchus* de Quatrefagus, *Ann. Sci. Nat.*, 17(3) : 325.

Marine and freshwater, parasitic for the most part upon turtles and tortoises. Body more or less flattened and divided into two distinct regions, a short narrow anterior "neck" and a large broad posterior portion or "abdomen". Posterior region with paired, lateral digitate branchae, without pulsating vesicles. Eyes one pair. Complete somite is biannulate anteriorly, but may become triannulate in the posterior region. Oral opening subterminal.

***Ozobranchus branchiatus* (Baird)**

1869. *Eubranchella branchiatus* Baird, *Proc. Zool. Soc. Lond.*, 310-318. (Type-Locality and Type-Deposited : Not known).

1974. *Ozobranchus branchiatus*, Sanjeeva Raj, *J. mar. biol. Ass. India*, 16(2) : 381-397.

1983. *Ozobranchus branchiatus*, Chandra, *Rec. zool. Surv. India*, 80 : 271.

Diagnostic characters : The species is generally 2.5cm long. It is always associated with *Chelonia mydas* (Linn.). Seven pairs of gills are present. (After Sanjeeva Raj, 1974).

Distribution ; India : Pirotan Island, Gulf of Kutch (Gujarat); Pulicate Lake, Bay of Bengal (Tamil Nadu). Outside India : South China Seas and Florida.

Field observation : Parasitic on fishes and turtles. The species is often associated with oozing patches or neoplastic epithelial tumours on eye-lids or neck or mucous junctions of mouth and nostrils.

Ozobranchus margo (Apathy)

1890. *Pseudobranchellion margo* Apathy, *Orvostermesztud Ertesito*, 15 : 110-113, 122-127. (Type-Locality and Type-Deposited : Not known).
1974. *Ozobranchus margo*, Sanjeeva Raj, *J. mar. biol. Ass. India*, 16(2) : 381-397.
1983. *Ozobranchus margo*, Chandra, *Rec. zool. Surv. India*, 80 : 271.

Diagnostic characters : The species is small sized. Gills present on either side of the abdomen, digitiform, several filaments on a single or divided stem. Five pairs of gills always present (After Sanjeeva Raj, 1974).

Distribution : India : Bay of Bengal at Ennore (Tamil Nadu). Outside India : Japan and South America.

Field observation : Little is know about its biology. It is cream coloured in preservative. Marine form, parasitic on fishes.

Ozobranchus polybranchus Sanjeeva Raj

1951. *Ozobranchus polybranchus* Sanjeeva Raj, *J. Zool. Soc. India*, 3 : 1-5. (Type-Locality : Porto Novo, Tamil Nadu ; Type-Deposited : Z S.I.).
1983. *Ozobranchus polybranchus*, Chandra, *Rec. zool. Surv. India*, 80 : 271.

Diagnostic characters : The body is divisible into an anterior neck and a posterior abdomen which terminates in a circular sucker. The neck is only half as broad as the abdomen and carries a ventrally directed sucker which bears a transverse mouth opening in its middle. The anterior end carries two small oval black eye-spots placed closely on either side of the median line. The genital opening is situated ventrally in the middle of the last somite of the neck region. The abdomen bears 20 branchiae each on right and left side. The abdomen narrows down to form a peduncle to which posterior sucker is attached. (Fig. 2).

Distribution : India : Porto-Novo (Tamil Nadu).

Field observation : Marine form, parasitic on turtles [*Pelochelys bebromi* (Gray)]. In life leech is of dull yellowish-green dorsally and pale-yellow ventrally. Dorsally the

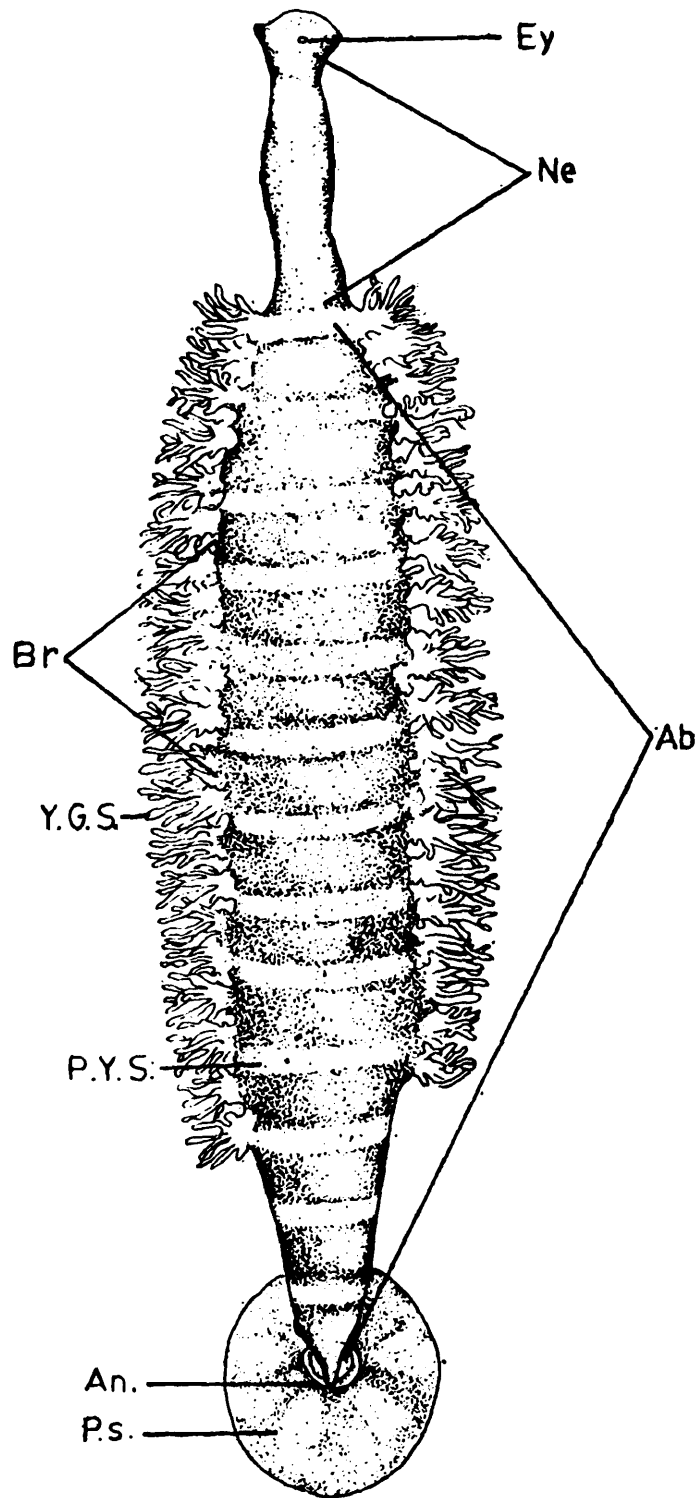

Fig. 2.

Fig. 2. *Ozobranthus polybranchus* (Sanjeeva Raj, 1951). Dorsal view of the entire animal in its expanded state. *ab.*, abdomen; *an.* anus; *br.*, branchia; *ey.*, eyes; *ne.*, neck; *p.s.*, posterior sucker; *y.g.s.*, yellow-green stripe; *p.y.s.*, pale yellow stripe. (After Sanjeeva Raj).

abdomen has broad yellowish green transverse stripes alternating with narrow paler ones.

Ozobranchus shipleyi Harding

1909. *Ozobranchus shipleyi*, Harding, *Proc. Camb. Phil. Soc.*, 15 : 233.
(Type-Locality : Sri Lanka ; Type-Deposited : Not known).
1983. *Ozobranchus shipleyi*, Chandra, *Rec. zool. Surv. India*, 80 : 271.

Diagnostic characters : Body flattened and translucent ; the posterior region with eleven pairs of lateral digitate branchiae. Mouth opening subterminal in the anterior sucker. Posterior sucker large, circular and centrally attached. Complete somites formed of two rings, Total number of rings 49. Eyes one pair in ring 5. (Fig.3).

Distribution : India ; Sambalpur (Orissa) ; River Ganges (West Bengal). Outside India : Pakistan.

Field observation : The dorsal surface in dull yellow with delicate variation of dark green at the margins. Posterior sucker speckled minutely with the same green, branchiae colourless and almost transparent.

Genus : **Piscicola** de Blainville

1818. *Piscicola* de Blainville, In Lamarck, *Histoire Naturelle des Animaux sans Vertebres*, V.

Small brackishwater and freshwater leeches parasitic generally upon fish. Body much attenuated, smooth and cylindrical, the posterior region with paired lateral pulsating vesicles. Suckers large excentrically attached. Mouth opening in the middle of the anterior sucker. Four eyes generally linear in form, upon the anterior sucker. Complete somites consists of fourteen rings.

Piscicola caeca Kaburaki

1921. *Piscicola caeca* Kaburaki, *Mem. Indian Mus.*, 5 : 661. (Type-
Locality : Chilka Lake, Orissa ; Type-Deposited : Not known).
1983. *Piscicola caeca*, Chandra, *Rec. zool. Surv. India*, 80 : 272.

Diagnostic characters : The slender, fusiform, translucent body and much flattened. Anterior sucker nearly circular,

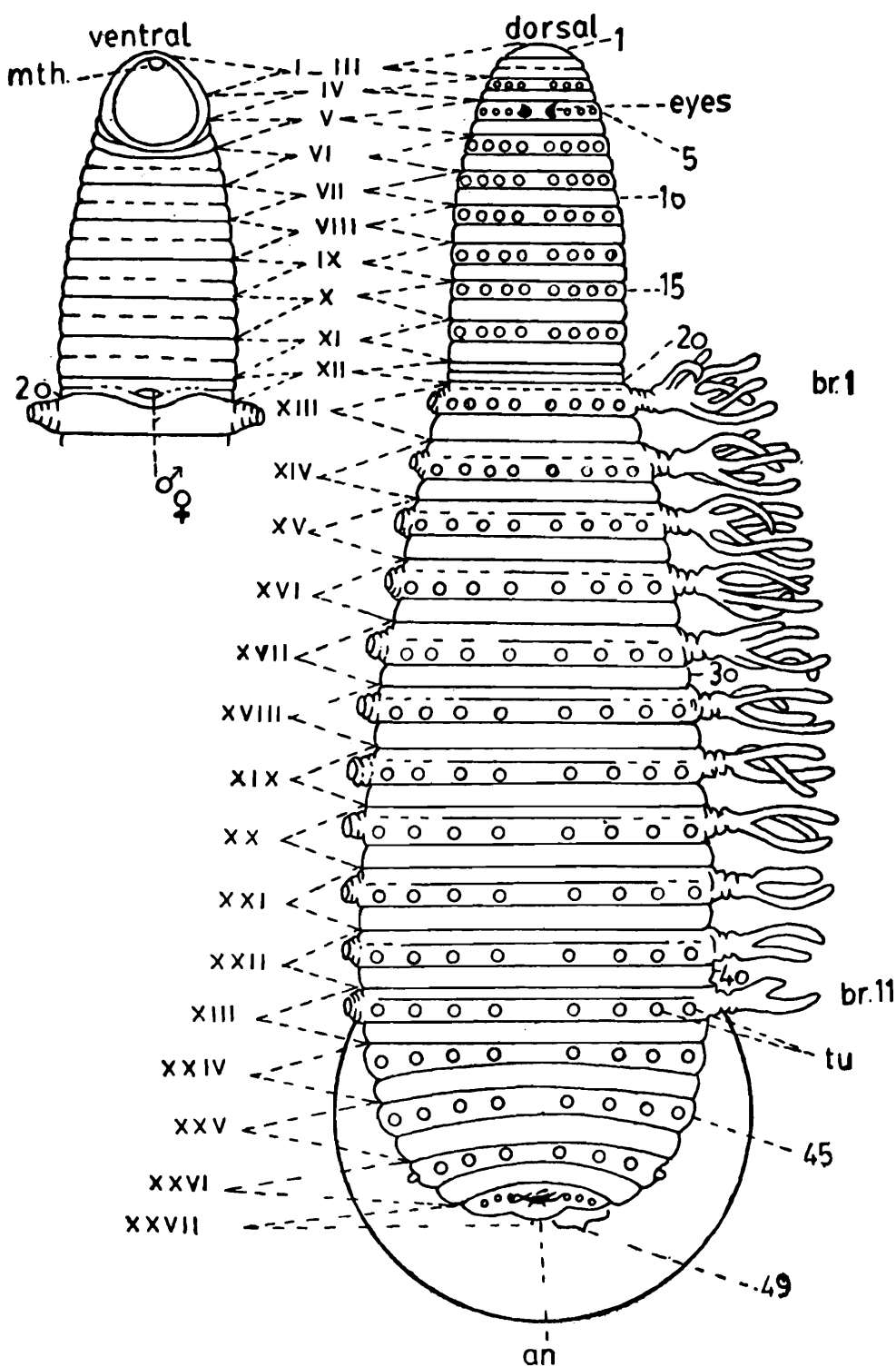

Fig. 3.

Fig. 3. *Ozobranchus shipleyi* (Harding, 1909). Diagram showing dorsal and parts of the ventral surface. Somites numbered in Roman and rings in ordinary figures. *mth.*, mouth; *an.*, anus; *br. 1* and *br. 11*, first and eleventh pairs of branchiae; *tu.*, tubercles. (After Harding).

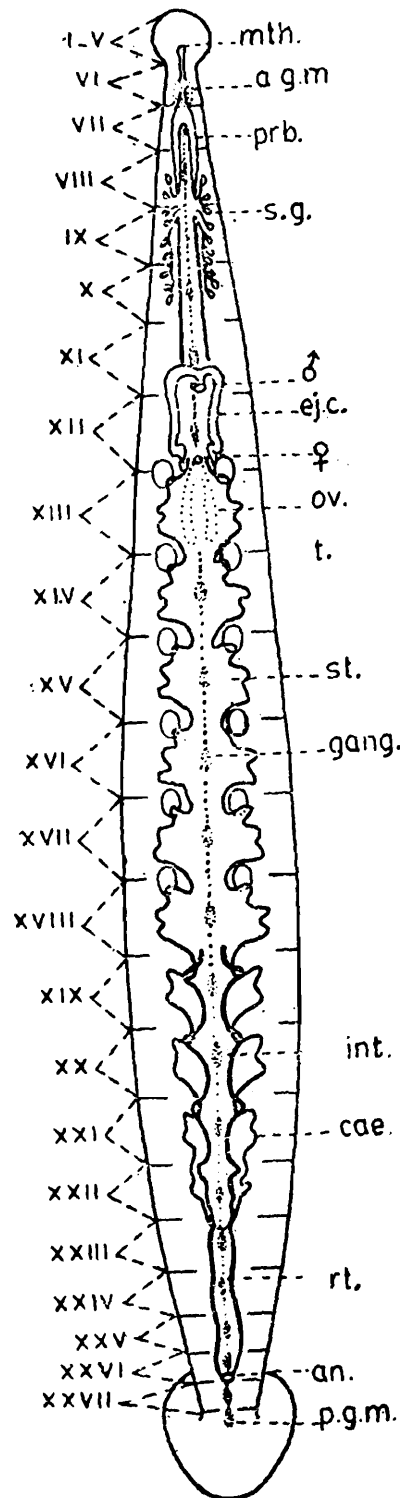

Fig. 4.

Fig. 4. *Piscicola caeca* (Kaburaki, 1921). Diagram showing external and internal features. Somites numbered in Roman figures. *a.g.m.*, anterior ganglionic mass; *gang.*, ventral ganglion; *mth.*, mouth-opening; *prb.*, proboscis; *s.g.*, salivary glands; *st.*, stomach; *cae.*, caecum; *int.*, intestine; *an.*, anus; *ej.c.*, ejaculatory canal; *ov.*, ovary; *t.*, testis. (After Kaburaki).

cupshaped and about half as wide as the heart-shaped posterior sucker. Eyes and pulsating vesicles absent. This species is an exception in the genus *Piscicola*. Complete somite formed of 14 rings. (Fig. 4).

Distribution : India : Chilka Lake (Orissa).

Field observation : Known from the lower surface of the body, gill slits, near anus, within the mouth and palate of *Trygon sephen* Forskal.

***Piscicola olivacea* Harding**

1920. *Piscicola olivacea* Harding, *Mem. Indian Mus.*, 5 : 510. (Type-
Locality : Chilka Lake, Orissa ; Type-Deposited : Not known).

1983. *Piscicola olivacea*, Chandra, *Rec. zool. Surv. India*, 80 : 272.

Diagnostic characters : Body circular, long and slender, varying in colour from bright to pale olive-green. Anterior sucker circular. Mouth opening in the centre of its interior cup. Posterior sucker somewhat heart shaped. Eyes two pairs, linear in form. Complete somite formed of 14 rings. A pair of lateral pulsating vesicles in eleven somites. (Fig. 5).

Distribution : India : Chilka Lake (Orissa) ; Laddak (Jammu and Kashmir).

Outside India : Soochow (China).

Field observation : Parasitic on *Trygon sephen* Forsk., *Tetrodon reticularis* Bl. and *Chatoessus chacunda* Ham-Buch. Three brown dorsal bands on the anterior sucker. Posterior sucker with seven pairs of whitish rays.

Genus : ***Pontobdellina* Harding**

1927. *Pontobdellina* Harding, *Fauna Brit. India, Hirudinea* : 44.

Marine leeches without eyes, pulsating vesicles or branchiae. Body more or less claviform which is sharply divided into two regions—a slender anterior “neck” and broad, posterior “abdominal” region. Body covered with conspicuous tubercles. Complete somite composed of three rings.

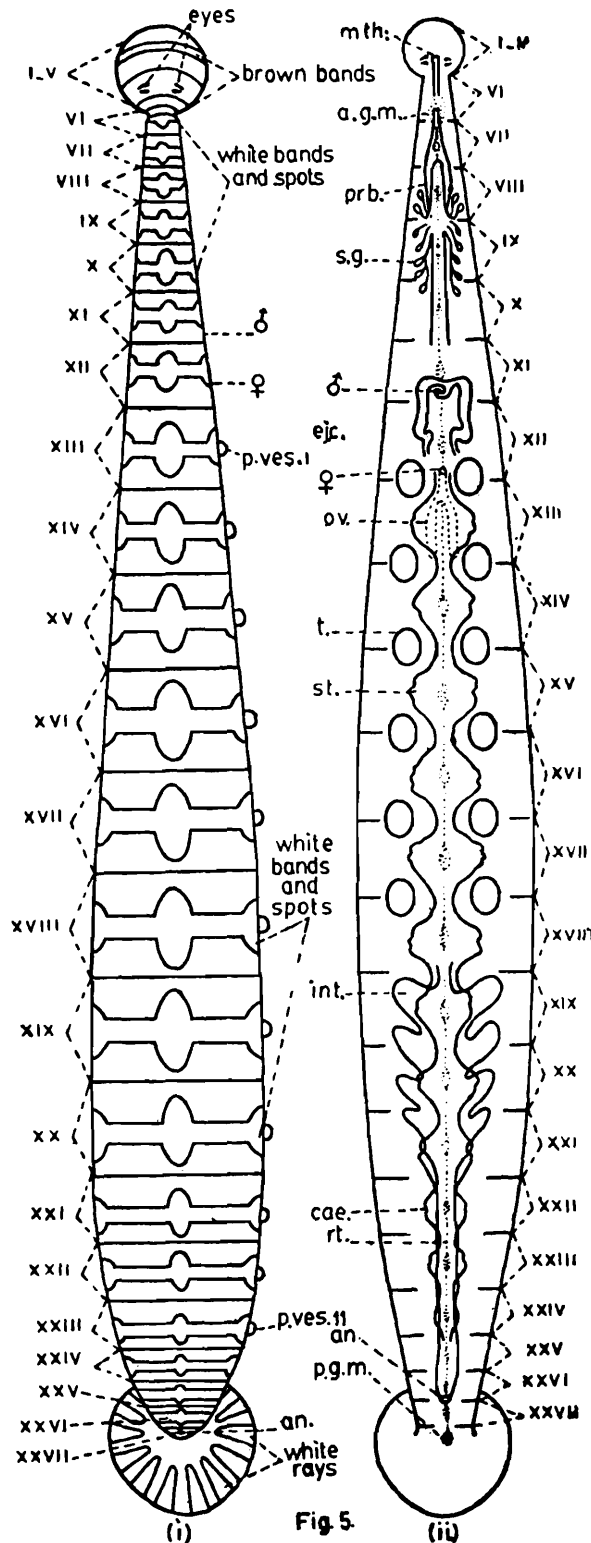

Fig. 5. *Piscicola olivacea* (Harding, 1920). (i) Diagram showing dorsal pattern and other external features on the left. *p.ves. I*, *p.ves. II*, pulsating vesicles (shown on one side only); *an.*, anus. (After Harding). (ii) Diagram showing alimentary tract, reproductive system and ventral nerve cord on the right. Somites numbered in Roman figures. *a.g.m.*, anterior ganglionic mass; *p.g.m.*, posterior ganglionic mass; *gang.*, ventral ganglion; *mth.*, mouth-opening; *s.g.*, salivary glands; *st.*, stomach; *int.*, intestine; *rt.*, rectum; *cae.*, caecum; *an.*, anus; *ejc.*, ejaculatory canal; *ov.*, ovary; *t.*, testis. (After Kaburaki).

Pontobdellina macrothela (Schmarda)

1861. *Pontobdella macrothela* Schmarda, *Neve wirbellose Thiere*, 1 : 2, Fol. Leipzig. (Type-Locality : Kingston, Jamaica ; Type-Deposited : Not known).
1983. *Pontobdellina macrothela*, Chandra, *Rec. zool. Surv. India*, 80 : 272.

Diagnostic characters : Body much flattened and divided into two very distinct regions ; a short slender "neck" and a long bulky "abdominal" region. Dorsal surface with a longitudinal medial groove, conspicuous on the posterior region. Anterior sucker slightly oval with six small conical, submarginal dorsal tubercles. Posterior sucker large and oval. Total number of rings 60. (Fig. 6).

Distribution : India : Off Gopalpur (Orissa).

Outside India : Sumatra, Sri Lanka, Australia, China, Jamaica and New South Wales.

Field observation : Bluish-Green to dark-green is colour, in live condition. Two dorsal, dark brown spots on the anterior sucker above the junction with the neck. Host recorded is *Zygaena* sp.

Genus : Pterobdella Kaburaki

1921. *Pterobdella Kaburaki*, *Mem. Indian Mus.*, 5 : 668. (Genotype : *Pterobdella amara*).

Brackishwater, ectoparasitic on fish. Body smooth and divided into three distinct regions, of which the anterior two are each provided with paired, lateral, fin-like processes. Without eyes or pulsating vesicles. Complete somites formed most probably of fourteen rings.

Pterobdella amara Kaburaki

1921. *Pterobdella amara* Kaburaki, *Mem. Indian Mus.*, 5 : 668. (Type-Localities : Chilka Lake, Orissa ; Type-Deposited : Not known).
1983. *Pterobdella amara*, Chandra, *Rec. zool. Surv. India*, 80 : 273.

Diagnostic characters : Body depressed anteriorly, and nearly circular posteriorly, and divided into three well marked regions. The two anterior regions are each expanded

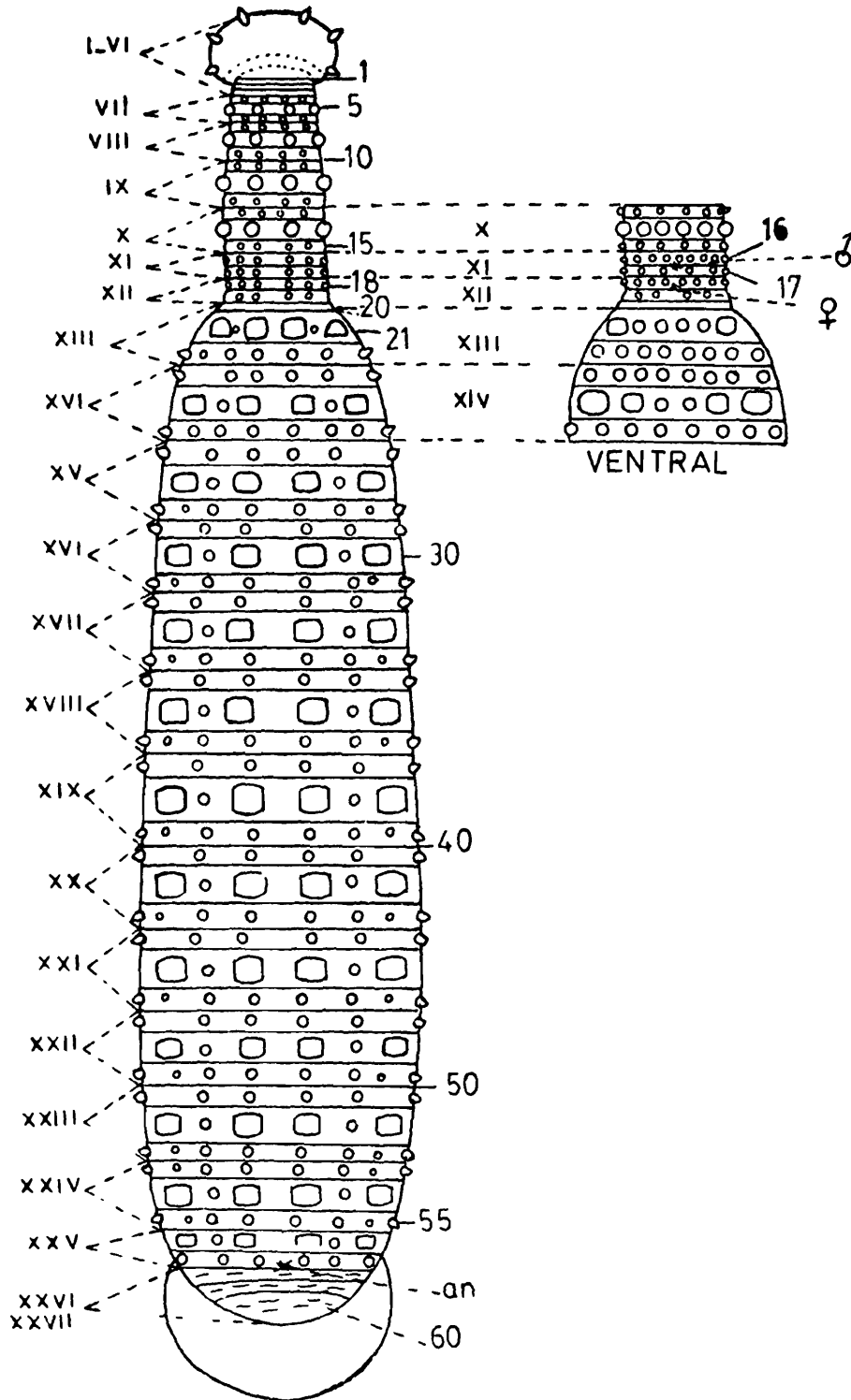

Fig. 6.

Fig. 6. *Pontobdellina macrothela* (Schmarda, 1861). Diagram showing external features on the right part of the ventral surface. Somites numbered in ordinary figures. an., anus. (After Harding).

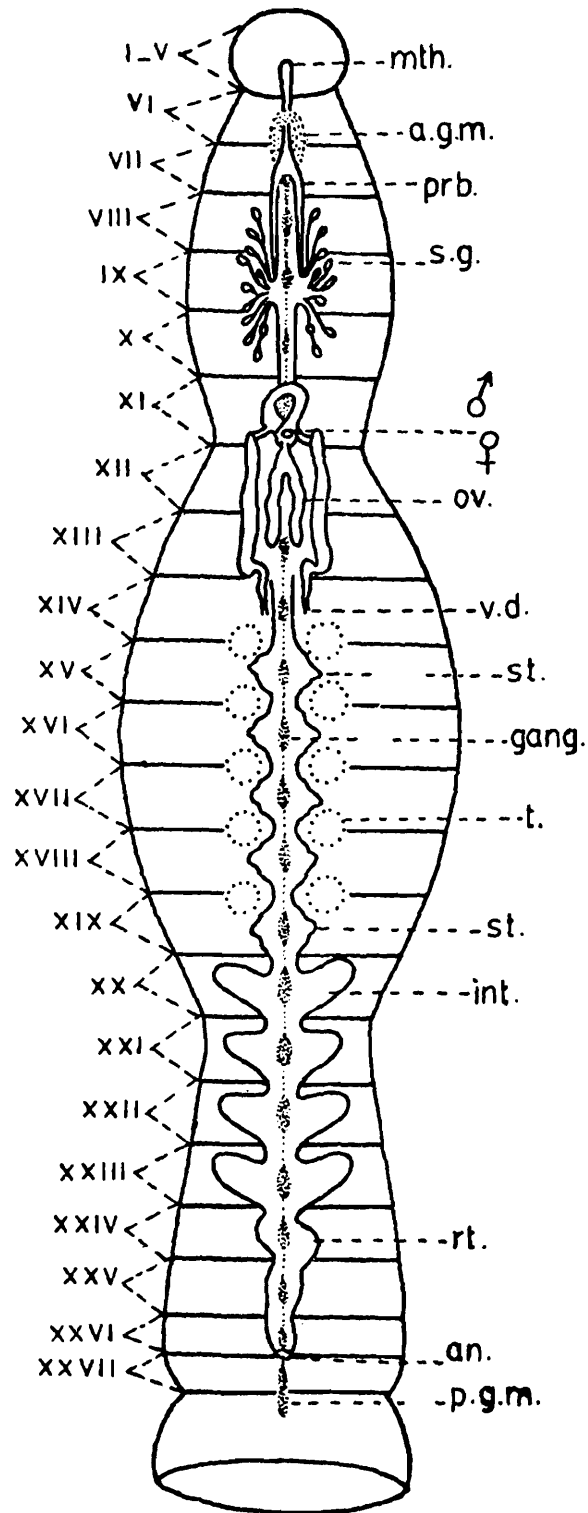

Fig.7.

Fig. 7. *Pterobdella amara* (Kaburaki, 1921). Diagram showing somites, ventral nerve-cord and the digestive and alimentary systems. Somites numbered in Roman figures. *mth.*, mouth; *a.g.m.*, anterior ganglionic mass; *gang.*, ventral ganglion; *prb.*, proboscis; *s.g.*, salivary glands; *ov.*, ovary; *v.d.*, vas deferens; *t.*, testis; *st.*, stomach; *int.*, intestine; *rt.*, rectum; *an.*, anus. (After Kaburaki).

laterally into paired, flattened, fin-like processes, a combination of features seen in no other known leech. Anterior sucker small, excentrically attached. Posterior sucker, thick, circular disc and centrally attached. Eyes absent. (Fig. 7).

Distribution : India : Chilka Lake (Orissa).

Field observation : Brackishwater form, parasitic on fish. Ground colour of the body white, occasionally with numerous minute pink spots on the dorsal surface.

Genus : *Zeylanicobdella* De Silva

1963. *Zeylanicobdella* De Silva, *Spolia Zeylan.*, 30 : 47 (Genotype : *Zeylanicobdella arugamensis*).

Small sized leeches, skin smooth with paired lateral pulsatile abdominal vesicles. Abdomen not distinctly marked off from the 'neck'. Fourteen or more annuli to a mid-body segment. Five pairs of testes. Coelomic system spacious as in *Piscicola*. Posterior crop caeca united into a single caecum.

Zeylanicobdella arugamensis De Silva

1963. *Zeylanicobdella arugamensis* De Silva, *Spolia Zeylan.*, 30(1) : 47-53 (Type-Locality : Arugam Kalapu, E. Province, Sri Lanka ; Type-Deposited : Colombo National Museum).

1983. *Zeylanicobdella arugamensis*, Chandra, *Rec. zool. Surv. India*, 80 : 273.

Diagnostic characters : The leeches are small sized. Body cylindrical. The anterior sucker is cupuliform with its dorsal portion longer than the ventral portion. A pair of conspicuous irregularly-shaped maroon to umber pigmented eyes is present on the lower third of the anterior sucker on its dorsal surface. The abdomen is not distinctly marked from the neck. The clitellum is not pronounced and genital pores are not discernible. The posterior sucker is large and discoidal. The fore part of the abdomen is the widest region

of the body. Ten pairs of lateral pulsatile abdominal vesicles occur laterally on the abdomen. (Fig. 8).

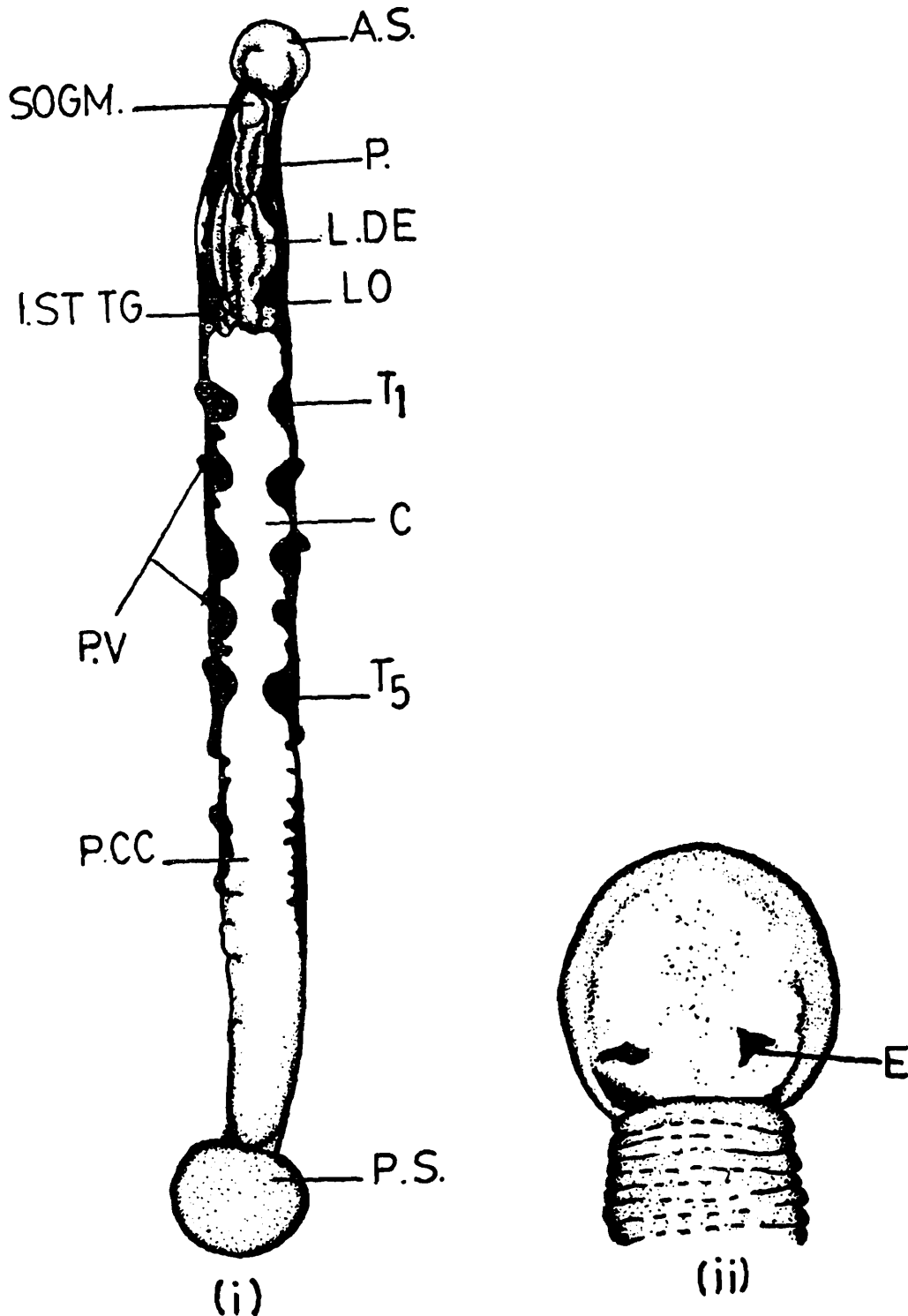

Fig. 8.

Fig. 8. *Zeylanicobdella arugamensis* (De Silva, 1963). (i) Diagram showing external features of whole mount. (Dorsal surface). A.S., anterior sucker; c., crop; Ist.C.G., Ist clitellar ganglion; L.D.F., left ductus ejaculatorius; L.O., left ovary; P., proboscis; P.C.C., posterior crop caecum; P.S., posterior sucker; P.V., pulsatile vesicle; SOGM., suboesophageal ganglion; T., testis; Ist.T.G., Ist testicular ganglion. (ii) Anterior sucker showing eyes. (After De Silva).

Distribution : India : Pulicate Lake, Bay of Bengal (Tamil Nadu).

Outside India : Sri Lanka and Malaysia.

Field observation : Brackishwater forms, parasitic on fishes. It looks like pale-yellowish ochre with the gut appearing green. In the engorged specimen it is bright red. A number of black dots can be observed on the dorsal surface arranged in three to five longitudinal rows.

Diagnostic Characters of : Family GLOSSIPHONIDAE

Freshwater leeches with ovate, flattened, never cylindrical body. Anterior sucker ventral and fused with the body. Posterior sucker cupuliform, distinct from the body, with more or less ventral aspect. Crop (or stomach) and intestine with conspicuous paired lateral caeca ; the intestine always with four pair. The young ones attach themselves to the ventral surface of the parentbody.

Key to the genera and species of the family GLOSSIPHONIDAE

1. Eyes less than four pairs.	...	2
Eyes four pairs.	...	23
2. Mouth opening subterminal in the anterior sucker.	...	3
Mouth opening in the middle of the anterior sucker.	...	10
3. Eyes one pair.	...	4
Eyes three pairs.	...	8
4. Eyes on ring three.	...	<i>Placobdella emydae</i>
Eyes on ring two.	...	5
5. Male gonopore between rings 24 and 25 ; total number of rings 66.	...	<i>Placobdella horai</i>
Male gonopore not between rings 24 and 25.	...	6
6. Male gonopore between rings 25 and 26 ; total number of rings 70.	...	<i>Placobdella indica</i>
Male gonopore not between rings 25 and 26.	...	7

- | | | | |
|-----|--|---|----|
| 7. | Male gonopore between rings 26 and 27 ;
total number of rings 71. ... | <i>Placobdella undulata</i> | |
| | Male gonopore between rings 26 and 27 ;
total number of rings 67. ... | <i>Placobdella fulva</i> | |
| 8. | Crop with seven pairs of lateral diverti-
cula. ... | <i>Placobdella ceylanica</i> | |
| | Crop with more than seven pairs of lateral
diverticula. ... | | 9 |
| 9. | Eyes on rings 3, 4 and 7 ; male gonopore
between rings 29 and 30. ... | <i>Paraclepsis praedatrix</i> | |
| | First two pairs of eyes on ring 2, third
pair on ring 5 ; male gonopore between
rings 27 and 28. ... | <i>Paraclepsis vulnifera</i> | |
| 10. | Eyes one pair, in ring 4. Eyes one pair, ...
in ring 3. ... | <i>Helobdella stagnalis</i>
<i>Helobdella nociva</i> | |
| | Eyes more than one pair. ... | | 11 |
| 11. | Crop with 6 or 7 pairs of lateral diverti-
cula. ... | | 12 |
| | Crop with 9 or more than nine pairs of
lateral diverticula. ... | | 20 |
| 12. | Crop with 6 pairs of lateral diverticula. ... | | 13 |
| | Crop with 7 pairs of lateral diverticula. ... | | 17 |
| 13. | Three pairs of eyes on contiguous
annuli. ... | | 14 |
| | Three pairs of eyes on rings 5, 7 and 8. ... | <i>Glossiphonia heteroclita</i> | |
| 14. | Three pairs of eyes in two rings. ... | | 15 |
| | Three pairs of eyes in three rings. ... | | 16 |
| 15. | 1st and 2nd pairs of eyes in ring 2 and
third pair in ring 4. ... | <i>Glossiphonia complanata</i>
<i>complanata</i> | |
| | 1st and 2nd pairs of eyes in ring 4 and
third pair in ring 5. ... | <i>Glossiphonia annandalei</i> | |
| 16. | Three pairs of eyes on rings 3, 4 and 5
respectively. ... | <i>Glossiphonia cruciata</i> | |
| | Three pairs of eyes on rings 6, 7 and 8
respectively. ... | <i>Glossiphonia weberi</i>
<i>weberi</i> | |
| 17. | Head separated from body by necklike
constriction ; gonopores separated by two
rings ; eyes two pairs. ... | | 18 |

- Head not separated from body by necklike constriction ; gonopores separated by one and half ring ; eyes three pairs. ... *Batracobdella hardingi*
18. First pair of eyes between rings 2 and 3 and second pair on 5. ... *Batracobdella lobata*
- First pair of eyes not between ring 2 and 3. ... 19
19. First pair of eyes on ring 2 and second pair on ring 3. ... *Batracobdella mahabiri*
- First pair of eyes on ring 4 and second pair on ring 5. ... *Batracobdella reticulata*
20. Three pairs of eyes ; cephalic region not dilated. ... 21
- Two pair of eyes ; cephalic region dilated. ... 22
21. Eyes on ring 2, 3 and 5 ; gonopores separated by one and a half rings. ... *Hemiclepsis bhatiai*
- Eyes on ring 3, 4 and 6 ; gonopores separated by two rings. ... *Hemiclepsis viridis*
22. Total number of rings 67. ... *Hemiclepsis marginata marginata*
- Total number of rings 72. ... *Hemiclepsis marginata asiatica*
23. Eyes on ring 2, 4, 7 and 10. ... *Theromyzon sexoculata*
- Eyes on ring 3, 5, 8 and 11. ... *Theromyzon mathai*

Genus : **Batracobdella** Vigner

1879. *Batracobdella* Vigner, *C. R. Acad. Sci. Paris*, 89 : 110-112.

Generally of small sized Glossiphonia. Body elongate, ovate or sublanceolate. Head and sucker either not separated from body or more or less widened respectively, definitely expanded. Caudal sucker circular or discoidal, distinct from body, centrally attached, directed ventrad. Body opaque, transparent, gelatinous or soft. Complete somite formed of three rings. Total number of rings between 67-74. Eyes typically one or two pairs, rarely three ; in certain cases coalescence possible in various combinations. Crop with seven pairs of lateral diverticula ; intestine with four pairs

of intestinal sac. Genital pores separated by two annuli rarely by 1 or $1\frac{1}{2}$ annuli.

Batracobdella hardingi Baugh

1960. *Batracobdella hardingi* Baugh, *Parasitology*, 50 : 287-301. (Type-
Locality : Monghyr, Bihar ; Type-Deposited : Z.S.I.).

1983. *Batracobdella hardingi*, Chandra, *Rec. zool. Surv. India*, 80 : 275.

Diagnostic characters : Three pairs of eyes on rings 2-3 and 6, first two pairs are coalesced. One postanal annulus. Total number of rings 70. The receptors are present in large

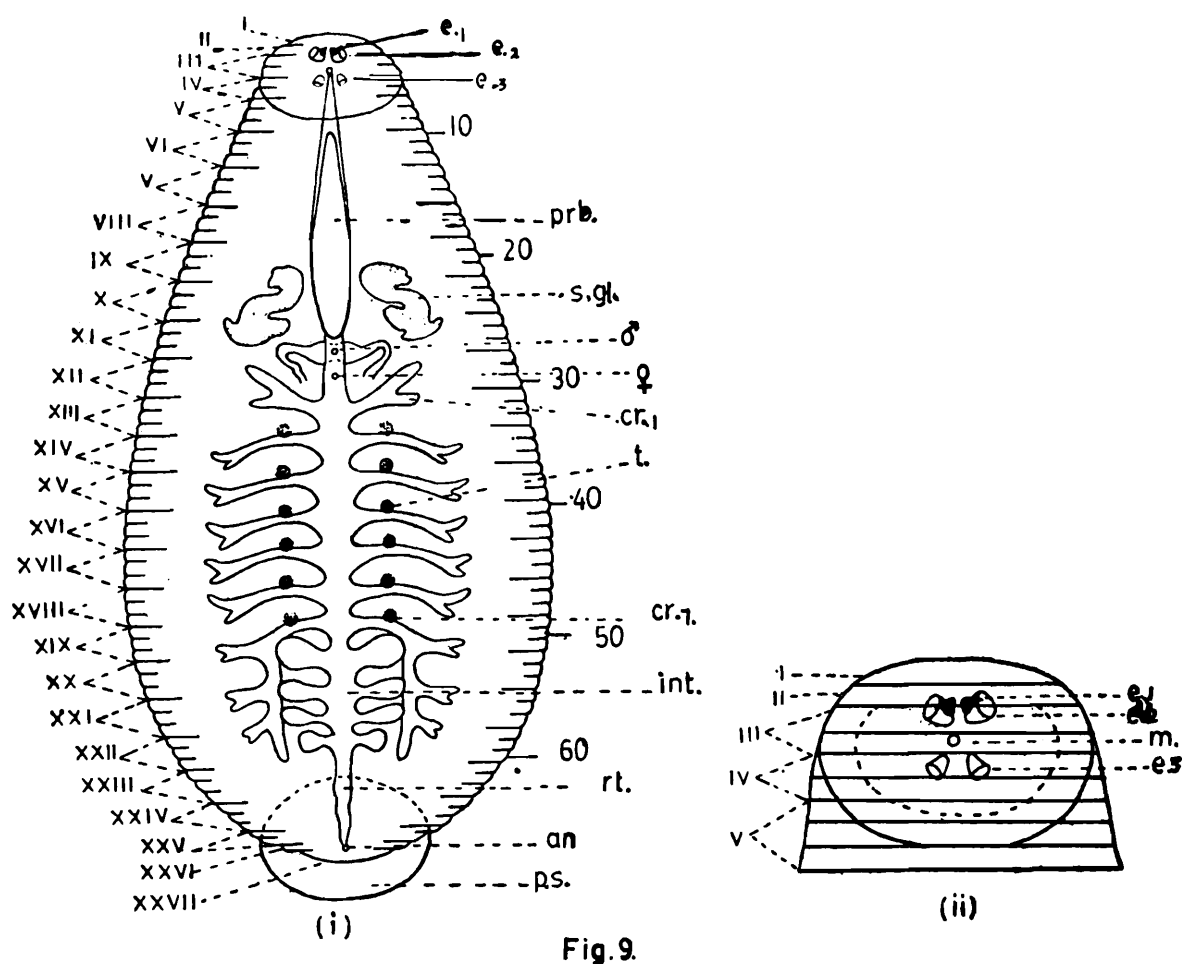

Fig.9.

Fig. 9. *Batracobdella hardingi* (Baugh, 1960). (i) Diagram showing the alimentary canal and reproductive organs. *an.*, anus ; *cr.1-cr.7*, seven pairs of crop caeca ; *e.1-e.3*, three pairs of eyes ; *int.*, intestine ; *prb.*, proboscis ; *p.s.*, posterior sucker ; *rt.*, rectum ; *S.gl.*, salivary glands ; *t.*, testis-sac. Somites numbered in Roman numerals. (ii) Dorsal view of the anterior end showing the position of the eyes and mouth. *e.1-e.3*, three pairs of eyes ; *m.*, mouth. (After Baugh).

numbers all over the dorsal surface of the body and for this reason the dorsal surface appears aerolated. The receptors are thickly set and form irregular rows on each annulus. Caudal sucker less than half of maximum width of the body. (Fig. 9).

Distribution : India : Monghyr (Bihar) ; Jammu (Jammu and Kashmir).

Field observation : Host unknown, free-living form, generally attached to submerged articles.

***Batracobdella lobata* (Bhatia)**

1934. *Glossiphonia lobata* Bhatia, *Annl. Parasit. hum. Comp.*, 12 : 121-129. (Type-Locality : Srinagar, Kashmir ; Type-Deposited : Not known).

1983. *Batracobdella lobata*, Chandra, *Rec. zool. Surv. India*, 80 : 275.

Diagnostic characters : Only one half postanal annulus. Total number of complete somites 21 ; a2 of each complete somite tinged dark, bearing 5-9 black spots. Caudal sucker with concentrically arranged pigmented stripes. Surface smooth, neither papillae or sensory papillae present. Two pairs of eyes behind one another on ring 2-3 and 5. Caudal sucker circular, its diameter about two-thirds of maximum body width. (Fig. 10).

Distribution : India : Srinagar (Jammu and Kashmir).

Field observation : Colour in life pale-green, with three dark-brown longitudinal (One median and two intermedian) stripes. Host not known.

***Batracobdella mahabiri* Baugh**

1960. *Batracobdella mahabiri* Baugh, *Zool. Anz.*, 165 : 463-477. (Type-Locality : Rewa, Madhya Pradesh ; Type-Deposited : Z.S.I.).

1983. *Batracobdella mahabiri*, Chandra, *Rec. zool. Surv. India*, 80 : 275.

Diagnostic characters : All three annuli of complete somites secondarily more or less distinctly divided. Total number of annuli 74. Mouth pore subterminal ; three pairs of compact salivary glands. A dark marginal spot on

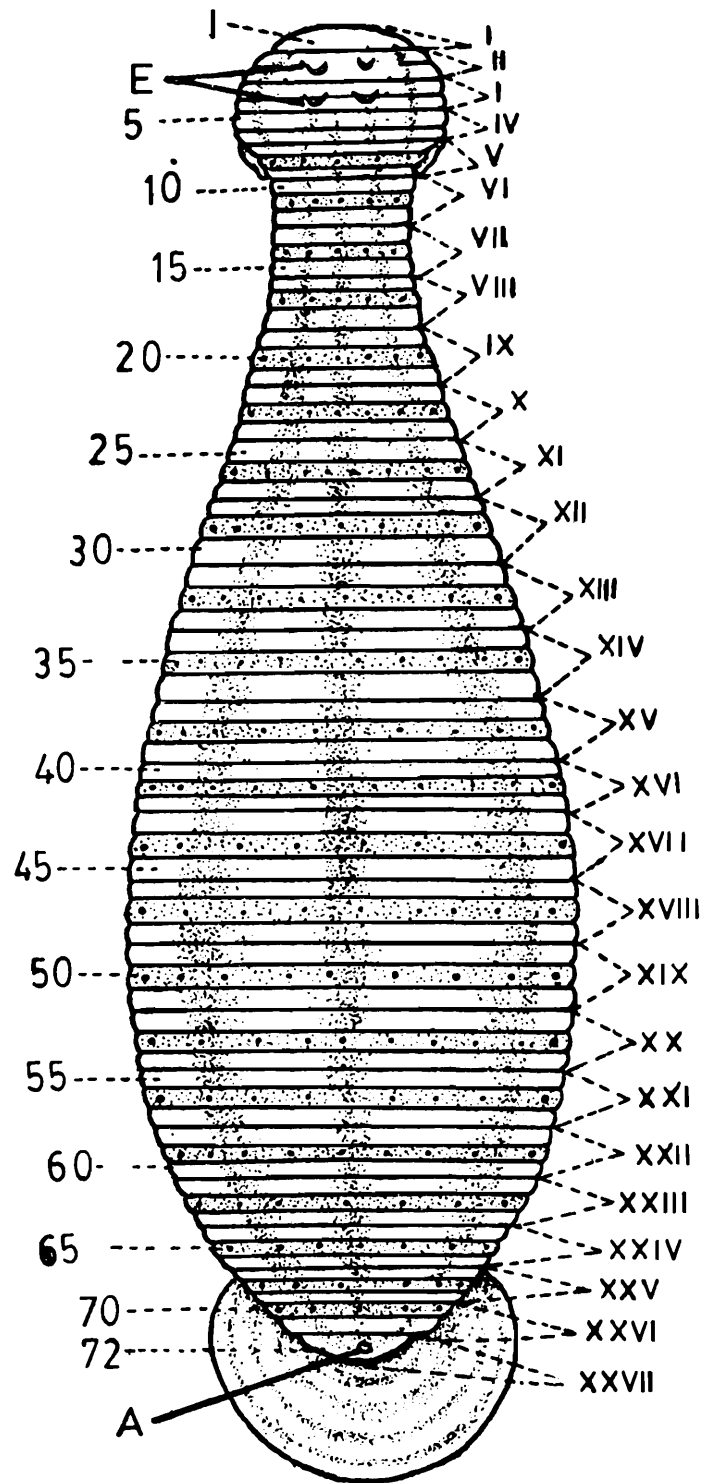

Fig.10.

Fig. 10. *Batracodella lobata* (Bhatia, 1934). Diagram showing important external features of dorsal surface. Somites are numbered in Roman and rings in arabic. *E.*, eyes; *A.*, anus. (After Bhatia).

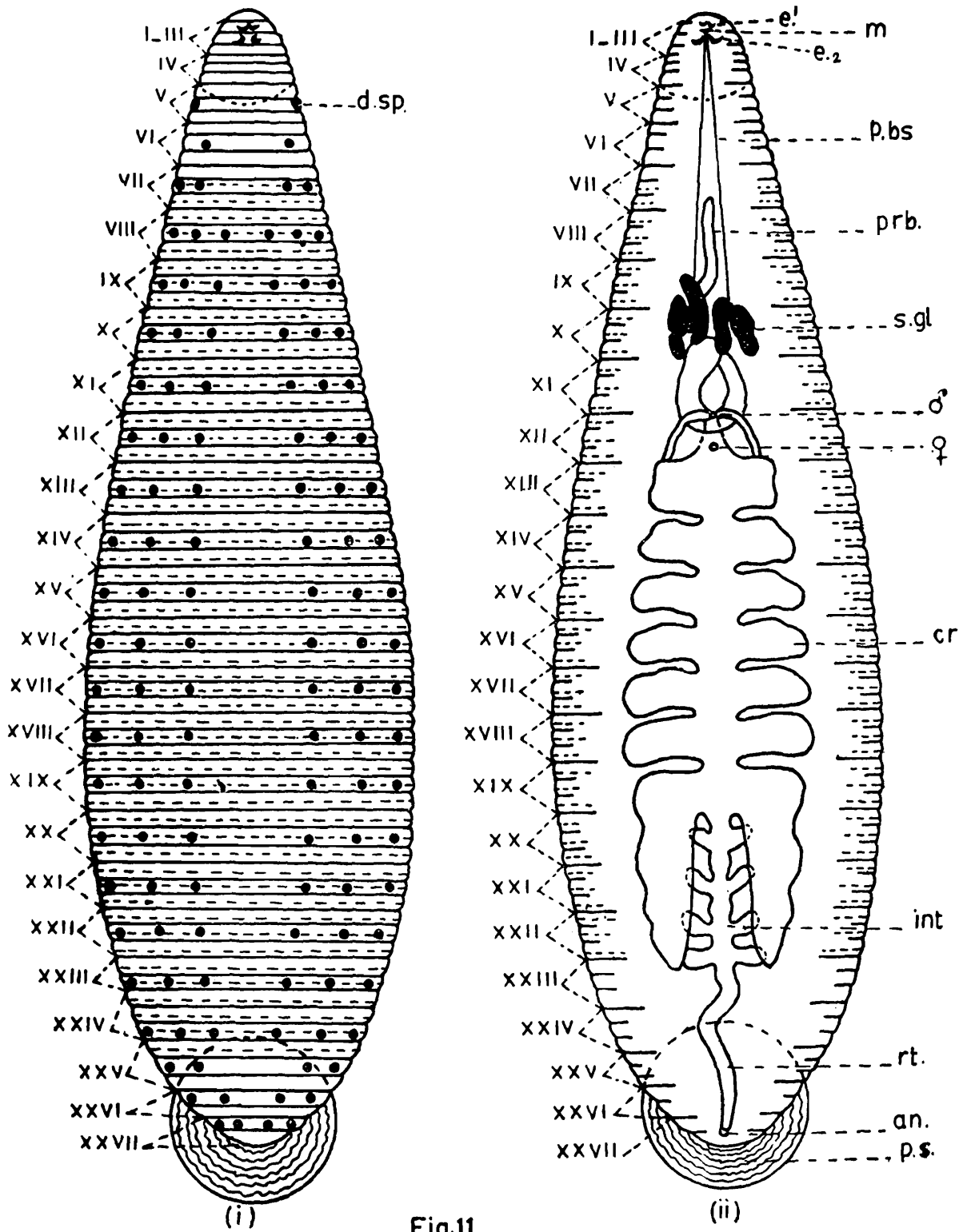

Fig.11.

Fig. 11. *Batracobdella mahibiri* (Baugh, 1960). (i) Diagram showing annulation and metameric spots. (ii) Diagram showing alimentary canal and reproductive organs. *an.*, anus; *cr.*, crop-stomach; *e.1* and *e.2*, 1st and 2nd pairs of eyes; *int.*, intestine; *m.*, mouth; *prb.*, proboscis; *prb.s.*, proboscis sac; *p.s.*, posterior sucker; *rt.*, rectum; *s.gl.*, salivary gland. Somites numbered in Roman figures. (After Baugh).

Va2 on both sides of the body. Two pairs of eyes on sub-triangular head in ring 2 and 3. Caudal sucker circular, diameter half of maximum body width; remarkably by showing dorsally 6-8 rings with sinous margins. (Fig. 11).

Distributiou : India : Rewa (Madhya Pradesh).

Field observation : Host unknown. Free-living, generally attached to submerged articles.

Batracobdella reticulata (Kaburaki)

1921. *Glossiphonia reticulata* Kaburaki, *Rec. Indian Mus.*, 22(5) : 689. (Type-Locality : Julundhar, Punjab ; Type-Deppsited : Z.S.I.).

1983. *Batracobdella reticulata*, Chandra, *Rec. zool. Surv. India*, 80 : 275.

Diagnostic characters : Two pairs of eyes in ring 4 and 5, two postanal annuli. Total number of rings 72. Caudal sucker small, diameter slightly longer than half of maximum body width. Three longitudinal rows of sensory papillae (one median and two intermedians), a number of irregularly arranged cutaneous papillae ; surface thus verrucose. (Fig. 12).

Distribution : India : Julundhar (Punjab) ; Sirmour and Bilaspur (Himachal Pradesh) ; Satara, Kolhapur (Maharashtra) ; Jammu (Jammu and Kashmir).

Field observation : Parasitic within the mantle cavity of *Anodonta* sp. Pigment more or less reticulated.

Genus : Glossiphonia Johnson

1816. *Glossiphonia* Johnson, *Treatise on the Medicinal Leech*. 8° London.

Generally of small size, with three or rarely with two pairs of eyes. Complete somite formed of three rings. Crop (or stomach) with six or rarely with seven pairs of sub-lobate, lateral caeca, the last and the longest pair reflected posteriorly. Mouth-opening within the anterior sucker.

Glossiphonia annandalei Oka

1921. *Glossiphonia annandalei* Oka, *Rec. Indian Mus* , 24(4) : 521. (Type- Locality : Inle Lake, Burma ; Type-Deposited : Not known).

1983. *Glossiphonia annandalei*, Chandra, *Rec. zool. Surv. India*, 80 : 273.

Diagnostic characters : Body elliptic-lanceolate, little

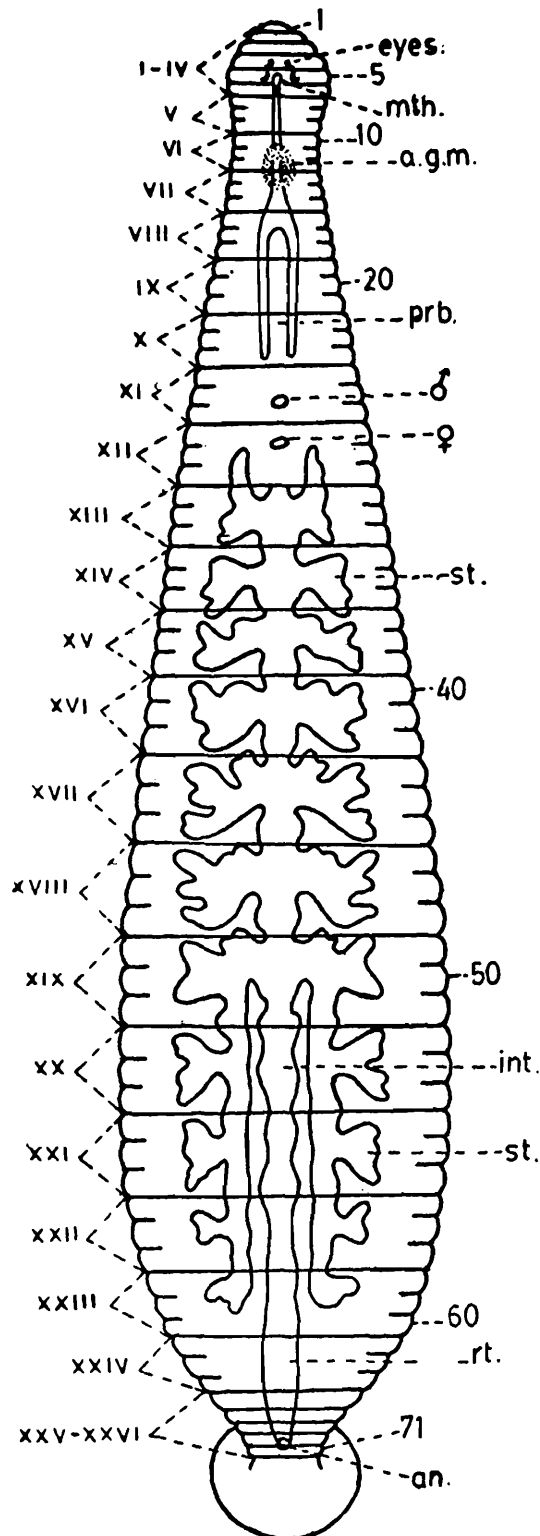

Fig.12.

Fig. 12. *Batracobdella reticulata* (Kaburaki, 1921). Diagram showing external features and alimentary tract. Somites numbered in Roman and rings in ordinary figures. *a.g.m.*, anterior ganglionic mass; *mth.*, mouth; *prb.*, proboscis; *st.*, stomach; *int.*, intestine; *rt.*, rectum; *an.*, anus. (After Kaburaki; slightly modified).

flattened, having a nearly smooth surface and the head region very slightly dilated. Posterior sucker circular and less in diameter than the greatest width of the body. Total number of rings 68. The three pairs of eyes has a position unique among the Glossiphoniidae which provides a ready means for recognizing this species. The two pairs of eyes lie in the posterior part of the ring 4, the smaller pair lies inbetween the larger pair. The third pair lies in ring 5 immediately below the large eyes in ring 4. (Fig. 13).

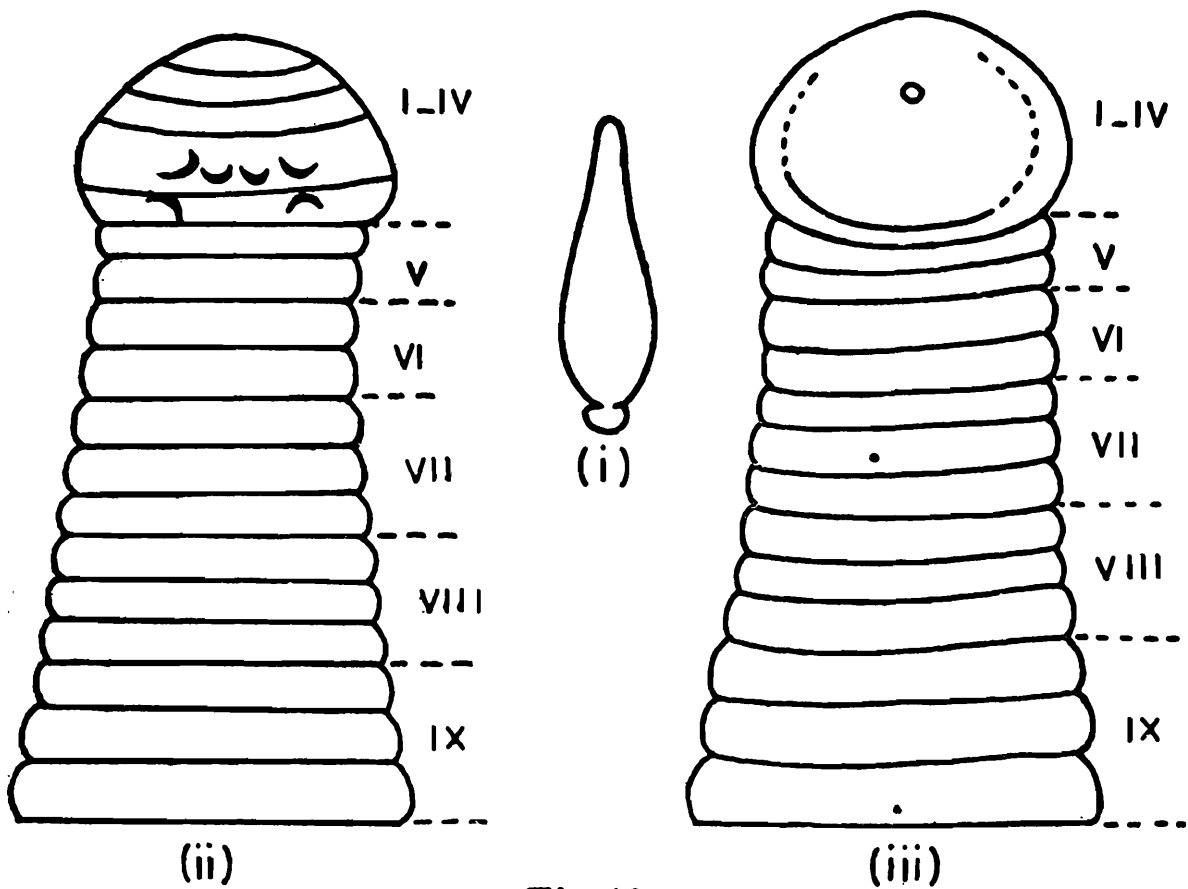

Fig.13.

Fig. 13. *Glossiphonia annandalei* (Oka, 1922). (i) Outline of entire leech, X3. (ii) Somites I-IX, dorsal view showing eyes, X30. (iii) Somites I-IX, ventral view showing mouth-opening, X30.

Distribution : India : Jaisalmer (Rajasthan) ; Satara, Kolhapur (Maharashtra) ; Chilka Lake (Orissa).

Outside India : Burma.

Field observation : Recorded colour in life is pale flesh-colour with minute dark dots on the dorsal surface tending to run into hair-like lines. Found in lakes and ponds. Ectoparasitic on molluscs and free-living.

***Glossiphonia complanata complanata* (Linnaeus)**

1758. *Hirudo complanata* Linnaeus, *Systema Naturae* 10th ed., 650. (Type-
Locality and Type-Deposited : Not known).

1983. *Glossiphonia complanata complanata*, Chandra, *Rec. zool. Surv. India*, 80 : 273.

Diagnostic characters : Body is ovate-elliptical, translucent and generally of a dull green or brownish colour. There are

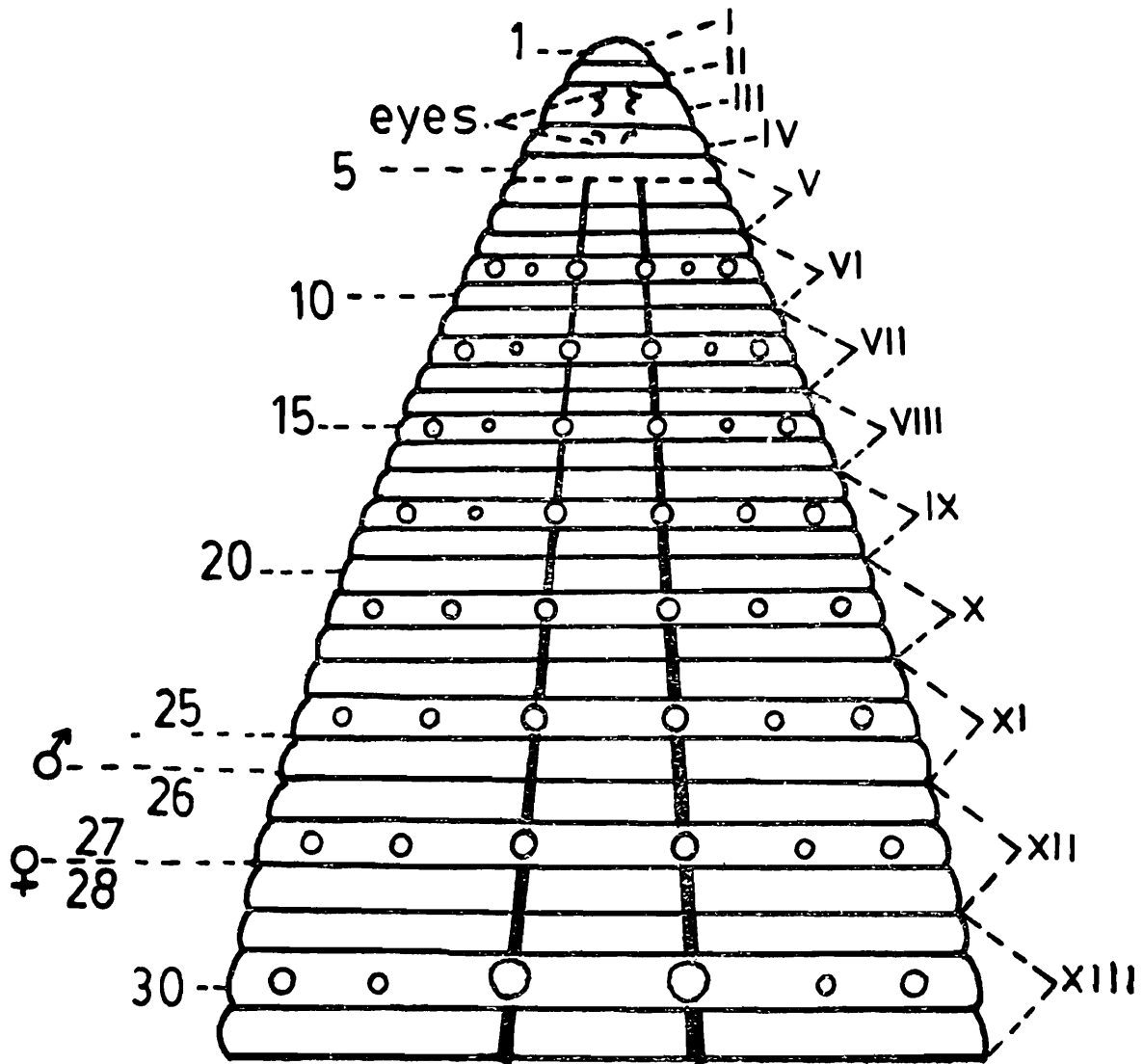

il.
Fig 14.(a)

Fig. 14. (a) *Glossiphonia complanata complanata* (Linn, 1758).
Diagrammatic representation of anterior part of dorsal surface.
Somites numbered in Roman and rings in ordinary figures.
il., interrupted dark lines.

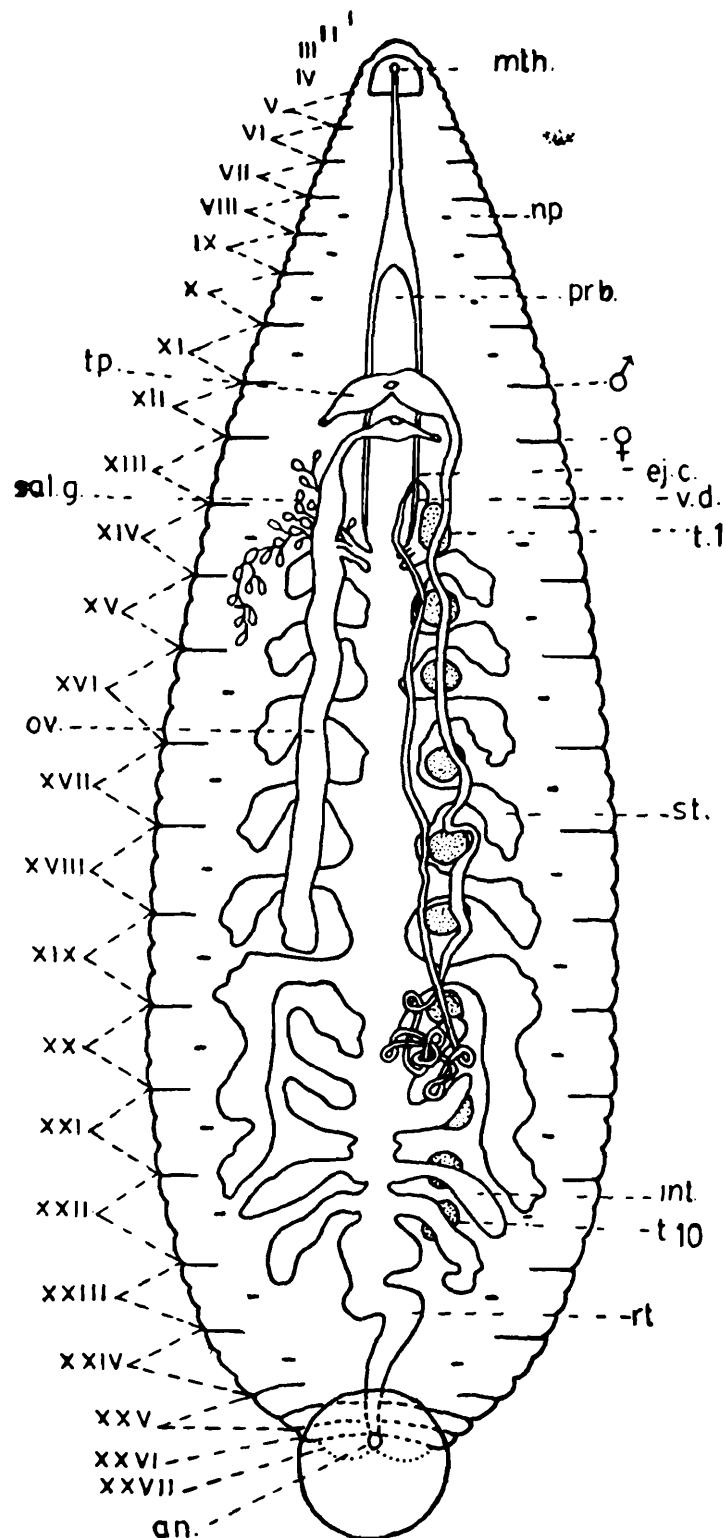

Fig.14.(b)

Fig. 14. (b) Diagram showing alimentary tract, reproductive system and annulation. *mth.*, mouth-opening; *prb.*, proboscis; *sal.g.*, salivary gland; *st.*, stomach; *int.*, intestine; *rt.*, rectum; *an.*, anus; *np.*, nephridiopore; *ej.c.*, ejaculatory canal; *t.1-t.10*, first and tenth pair of testes; *ov.*, ovary. (After Harding).

six longitudinal rows of yellow spots which lie on the middle annuli of each somite. Six eyes lie in the two close sub-parallel rows. Ist and second pair of eyes lie in ring 3 and the third pair in ring 5. Total number of rings 68. The stomach has six pairs of lateral diverticula, the last being reflected posteriorly. (Fig. 14).

Distribution : India : Srinagar (Jammu and Kashmir).
Outside India : Japan, U. S. A. and Europe.

Field observation : The species is sluggish and found in ponds and slow moving streams. Found attached to under-surface of submerged articles and aquatic vegetation. Parasitic chiefly on molluscs.

Glossiphonia cruciata Bhatia

1930. *Glossiphonia cruciata* Bhatia, *Annls. Parasit. hum. Camp.*, 8 : 344-348. (Type-Locality : Achabal, Kashmir ; Type-Deposited : Not known).

1983. *Glossiphonia cruciata*, Chandra, *Rec. zool. Surv. India*, 80 : 274.

Diagnostic characters : Body elliptic-claviform, transparent, general colour pale-green. Dorsal surface presents a roughened appearance due to presence of numerous papillae regularly on each ring. Total number of rings 70. Three pairs of eyes are disposed on rings 3, 4 and 5. The stomach has six pairs of simple diverticula. Head region somewhat dilated, but continuous with the body. (Fig. 15).

Distribution : India : Achabal, Anantanag (Jammu and Kashmir).

Field observation : The species can be found in lakes, ponds and small hill streams having aquatic vegetation. They are found free-living or attached to submerged particles.

Glossiphonia heteroclita (Linnaeus)

1761. *Hirudo heteroclita* Linnaeus, *Fauna Suecica*, 2nd ed., (Type-Locality and Type-Deposited : Not known).

1983. *Glossiphonia heteroclita*, Chandra, *Rec. zool. Surv. India*, 80 : 274.

Diagnostic characters : The body is ovate acuminate, flattened, smooth, transparent. The three pairs of eyes

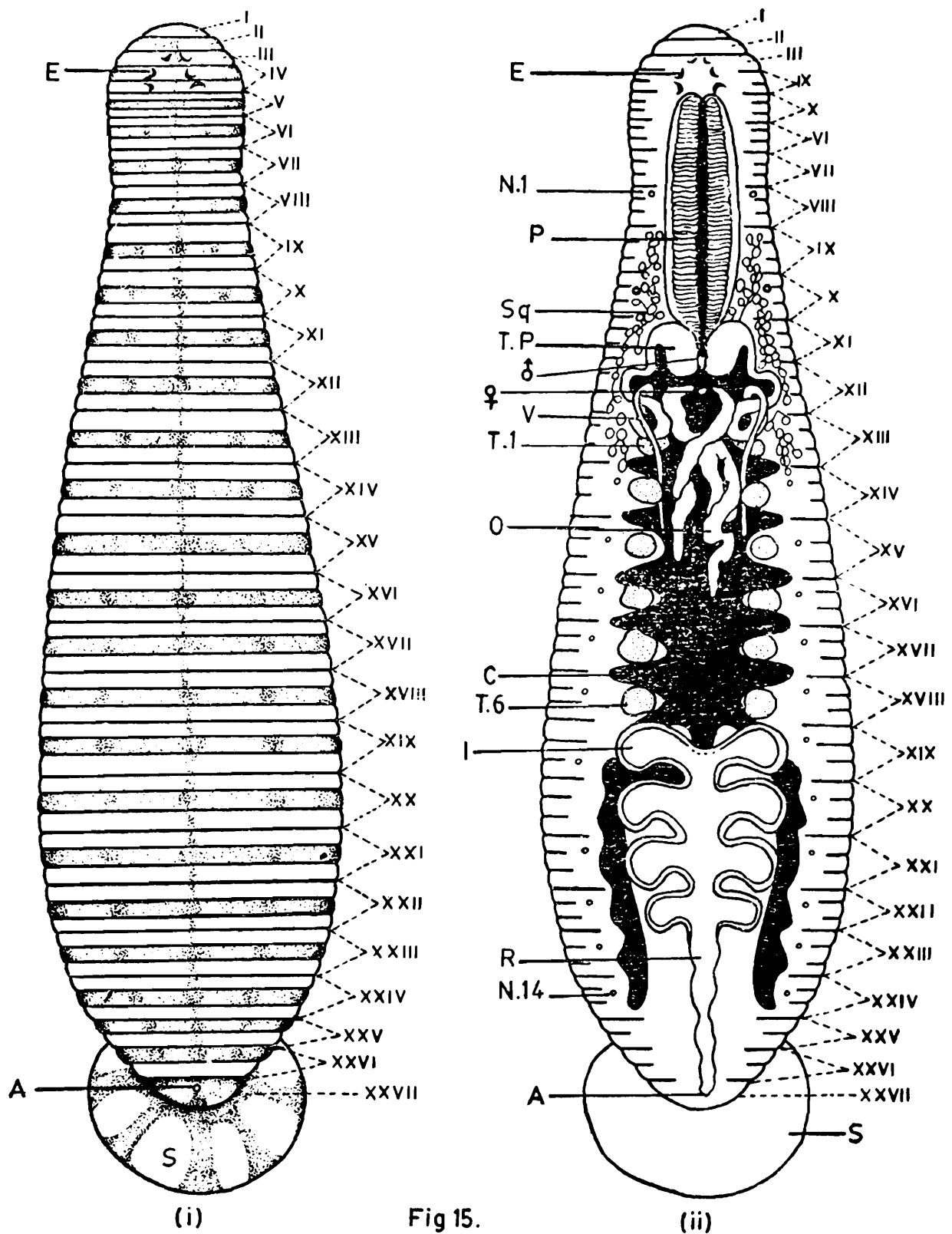

Fig 15.

Fig. 15. *Glossiphonia cruciata* (Bhatia, 1930). (i) Diagram showing structure of metameric spots and annulation. Somites are numbered in Roman. A., anus; E., eyes; S., posterior sucker. (ii) Diagram showing important external and internal characters. The somites are numbered in Roman. E., eyes; I., intestine; N.1-N.14, paired nephridiopores (ventral); O., ovary; P., proboscis; R., rectum; S., posterior sucker; S.G., salivary gland; T1-T6, testicles; T.P., terminal portion; V., vas deferens; ♂., male genital pore; ♀., female genital pore. (After Bhatia).

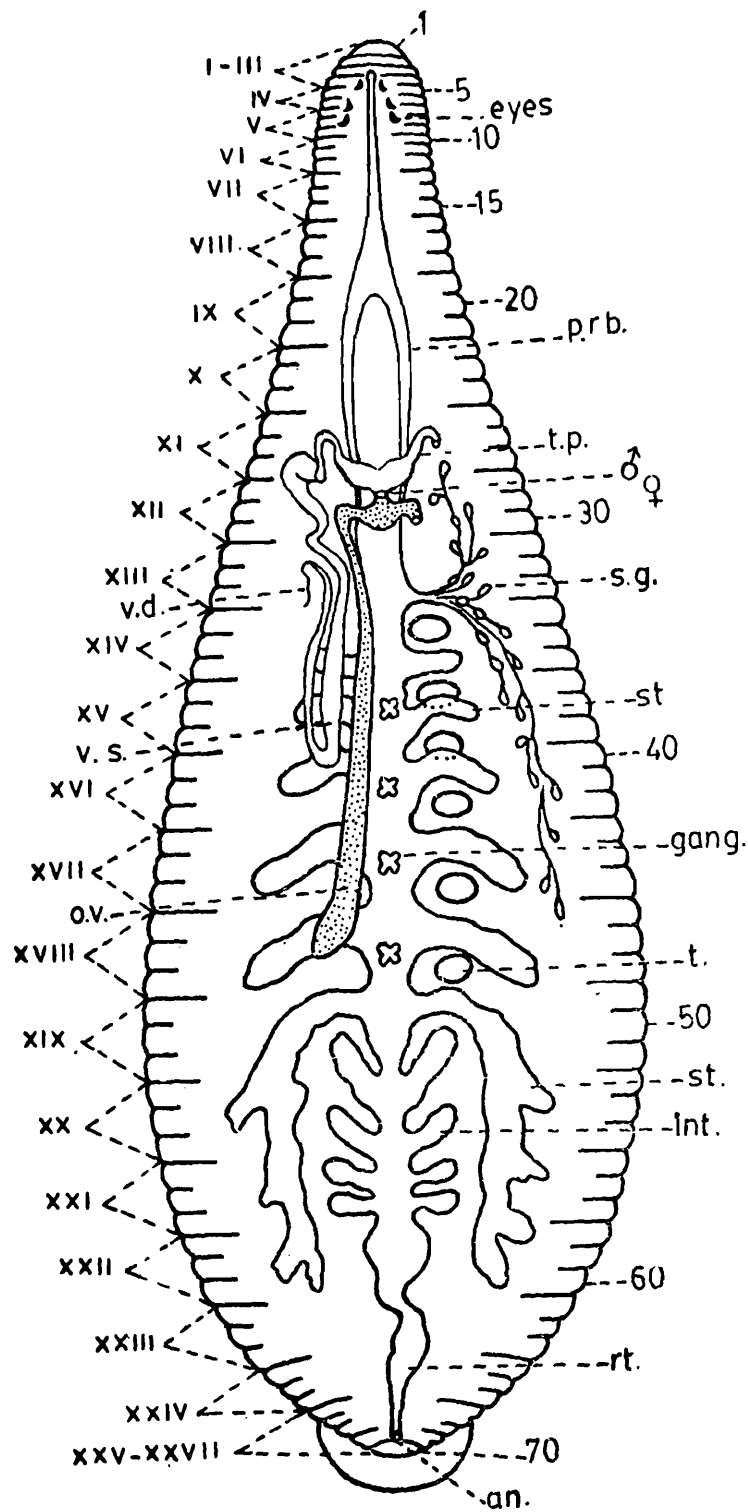

Fig.16.

Fig. 16. *Glossiphonia heteroclita* (Linn., 1761). Diagram showing annulation, alimentary tract and reproductive system. Somites numbered in Roman and rings in ordinary figures. *mth.*, mouth-opening; *prb.*, proboscis; *s.g.*, salivary glands; *st.*, stomach; *int.*, intestine; *rt.*, rectum; *an.*, anus; *tp.*, terminal portion of ejaculatory canal; *v.s.*, vesicula seminalis or seminal/reservoir; *v.d.*, vas deferens; *t.*, testis; *ov.*, ovary. (After Harding).

generally lie in rings 5,7 and 8 respectively. The first and smallest pair of eyes closely approximated. The second and third pair which are widely separated but the components lie near together forming three groups corresponding to the points of an equilateral triangle. Total number of rings 70. (Fig. 16).

Distribution : India ; Nagaur (Rajasthan) ; Monghyr (Bihar). Outside India : North America, Europe and Burma.

Field observation : The species is of clear amber-yellow colour, pigmented areas of a darker colour may or may not be present on the dorsal surface. It is found in lakes and ponds, free-living or attached to sub-merged articles. Parasitic chiefly on molluscs.

Glossiphonia weberi weberi Blanchard

1897. *Glossiphonia weberi* Blanchard, *Zool. Ergeb. einer Reise in Niederlandische Ost-Indian*, Max Weber, 4 : 332. (Type-Locality : Sumatra ; Type-Deposited : Not known).

1983. *Glossiphonia weberi weberi*, Chandra, *Rec. zool. Surv. India*, 80 : 274.

Diagnostic characters : Body translucent, ovate-acuminate, in contraction nearly triangular, the dorsal surface with roughened appearance due to presence of numerous tubercles transversely upon every ring. Dorsal surface bears a series of prominent metameric papillae forming seven longitudinal rows. In alcohol the general colour is greyish or greenish-white to orange. The posterior sucker smaller than the greatest width of the body, its upper surface bears paired radial stripes of the same dark pigment which occurs upon the body. Total number of rings 70. Three pairs of eyes variable in position but generally occurs on rings 6,7 and 8 disposed in the form of three points of a triangle. (Fig. 17).

Distribution : India : Widely distributed throughout India. Outside India : Pakistan, Nepal, Burma and Sumatra.

Field observation : The species is found in lakes, ponds and streams, attached to submerged particles or free-living. Ectoparasitic, the hosts recorded are molluscs, aquatic beetles and amphibians,

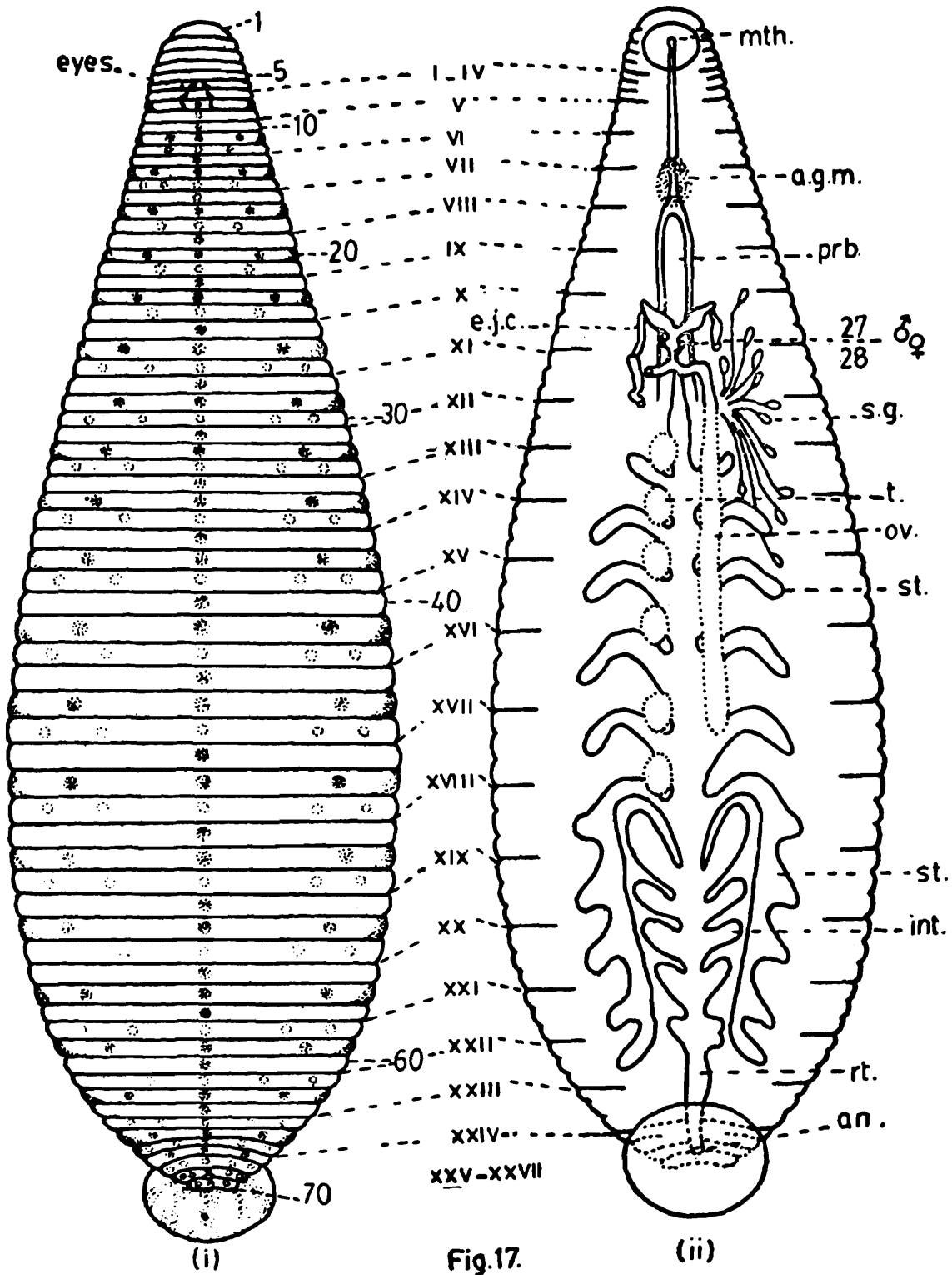

Fig. 17. *Glossiphonia weberi weberi* (Blanchard, 1897). (i) Dorsal aspect, showing external features, and seven longitudinal row of papillae in dotted lines, the dark pigment being indicated by dotted shading. Somites numbered in Roman and rings in ordinary figures. (ii) Ventral aspect, showing reproductive organs, digestive tract etc. *mth.*, mouth; *a.g.m.*, anterior ganglionic mass; *prb.*, proboscis; *s.g.*, salivary glands; *st.*, stomach; *int.*, intestine; *rt.*, rectum *an.*, anus; *ej.c.*, ejaculatory canal; *t.*, testis; *ov.*, ovary. (After Harding slightly modified).

Genus : **Helobdella** Blanchard

1896. *Helobdella* Blanchard, *Boll. Mus. Zool. Torino*, XI, No. 263.

Small Glossiphonidae with one pair of eyes. Complete somite formed of three rings. Body generally without papillae. Mouth opening within the anterior sucker. Head region continuous with the rest of the body. Crop (or stomach) with six pairs of simple lateral caeca, the last and longest reflected posteriorly. Sometimes with a dorsal chitinous scute.

Helobdella nociva Harding

1924. *Helobdella nociva* Harding, *Ann. mag. nat. Hist.*, Ser. 9, 14 : 489. (Type-Locality and Type-Deposited : Not known).

1983. *Helobdella nociva*, Chandra, *Rec. zool. Surv. India*, 80 : 276.

Diagnostic characters : Body claviform, slender anteriorly, with the head region somewhat dilated, without a dorsal scute. Posterior sucker small, less in width than half the greatest width of the body. Total number of rings 70. Single pair of eyes in ring 4. The male and female genital orifice is separated by two annuli. The six pairs of crop caeca are somewhat lobed. (Fig. 18).

Distribution : India : Solan (Himachal Pradesh) ; Calcutta (West Bengal) ; Puri (Orissa) ; Poonch, Udhampur (Jammu and Kashmir).

Field observation : Host unknown, free-living form, generally attached to submerged articles. Translucent body with five brown, longitudinal stripes of which one is median.

Helobdella stagnalis (Linnaeus)

1758. *Hirudo stagnalis* Linnaeus, *Systema Naturae*, 10th ed. (Type-Localities and Type-Deposited : Not known).

1983. *Helobdella stagnalis*, Chandra, *Rec. zool. Surv. India*, 80 : 276.

Diagnostic characters : The species has a slender body. A dorsal circular plate or scute, situated between the twelfth and thirteenth rings, forming the most striking external feature. Posterior sucker small, its width being greater than

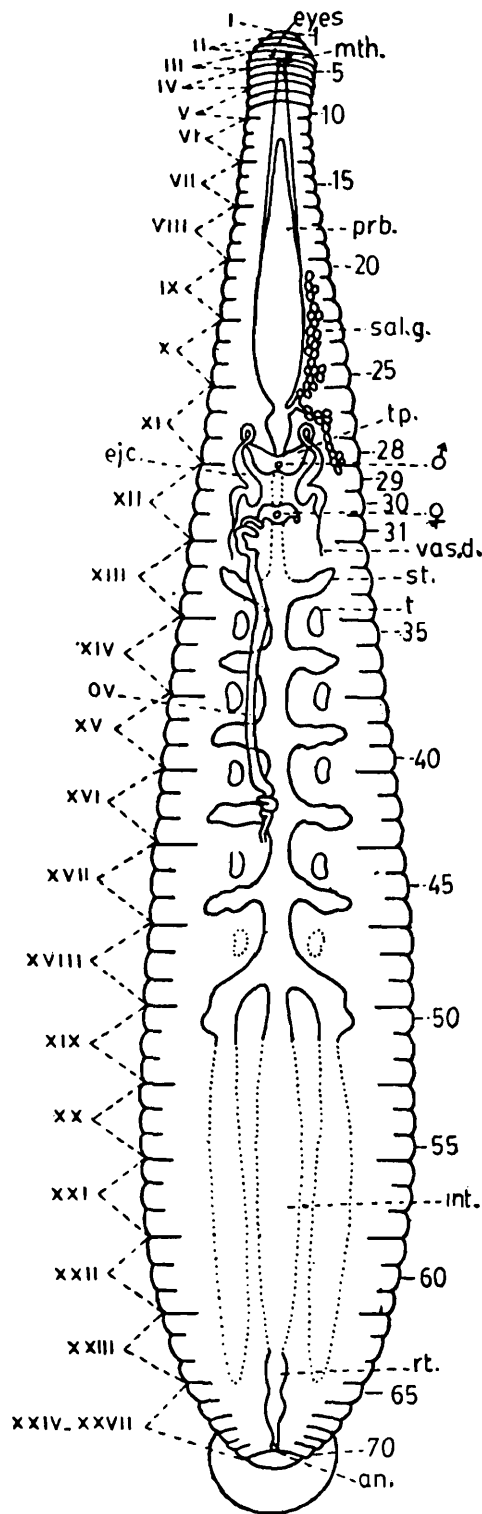

Fig.18.

Fig. 18. *Helobdella nociva* (Harding, 1924). Diagram showing external feature and the reproductive and alimentary systems. Somites numbered in Roman and rings in ordinary figures. *mth.*, mouth-opening; *prb.*, proboscis; *sal.g.*, salivary glands; *ej.c.*, ejaculatory canal; *vas.d.*, vas deferens; *t.*, testis; *ov.*, ovary; (Shown one side only for the sake of clearness); *st.*, stomach; *rt.*, rectum; *int.*, intestine; *an.*, anus. The dotted portion of the alimentary tract could not be seen owing to the state of the material. (After Harding).

about half the greatest width of the body. Total number of rings 68. The single pair of eyes lie closely approximated in the third ring or between rings 2 and 3. The first five pairs of lateral gastric caeca, when undistended by food may become difficult to detect. (Fig. 19).

Distribution : India : Srinagar, Poonch, Udhampur (Jammu and Kashmir) ; Solan, Sirmour (Himachal Pradesh). Outside India : Canada, U.S.A. and Paraguay.

Field observation : Chiefly parasitic on Gastropods but occasionally may be found on the bodies of frogs and injured fish and submerged articles in ponds, tanks and slow moving streams.

Genus : *Hemiclepsis* Vejdovsky

1883. *Hemiclepsis* Vejdovsky, *Sitzb. des Konigl. Bohm. Gesel. des Wissensch.*, Prag. : 35-51.

Glossiphonidae of medium size, typically with two pairs of eyes. Complete somite formed of three rings. Head region dilated and distinct from the rest of the body. The crop (or stomach), has more than seven pairs of lateral diverticula, extends anteriorly into the preclitellar region. Mouth-opening within the anterior sucker.

Hemiclepsis bhatiai Baugh

1960. *Hemiclepsis bhatiai* Baugh, *Parasitology*, 50 : 287-301. (Type-Loeality : Kalipahar, Monghyr, Bihar ; Type-Deposited : Z.S.I.).

1983. *Hemiclepsis bhatiai*, Chandra, *Rec. zool. Surv. India*, 80 : 278.

Diagnostic characters : Body claviform, cephalic region slightly expanded. Three pairs of cuped shaped eyes arranged in two longitudinal rows in the cephalic region on rings 2, 3, and 5. The eyes of the first pair is smallest, second pair is the largest and the third pair is intermediate. The relative size of this form is the characteristic. Preserved specimens appear light cream-coloured, against which dull light brown

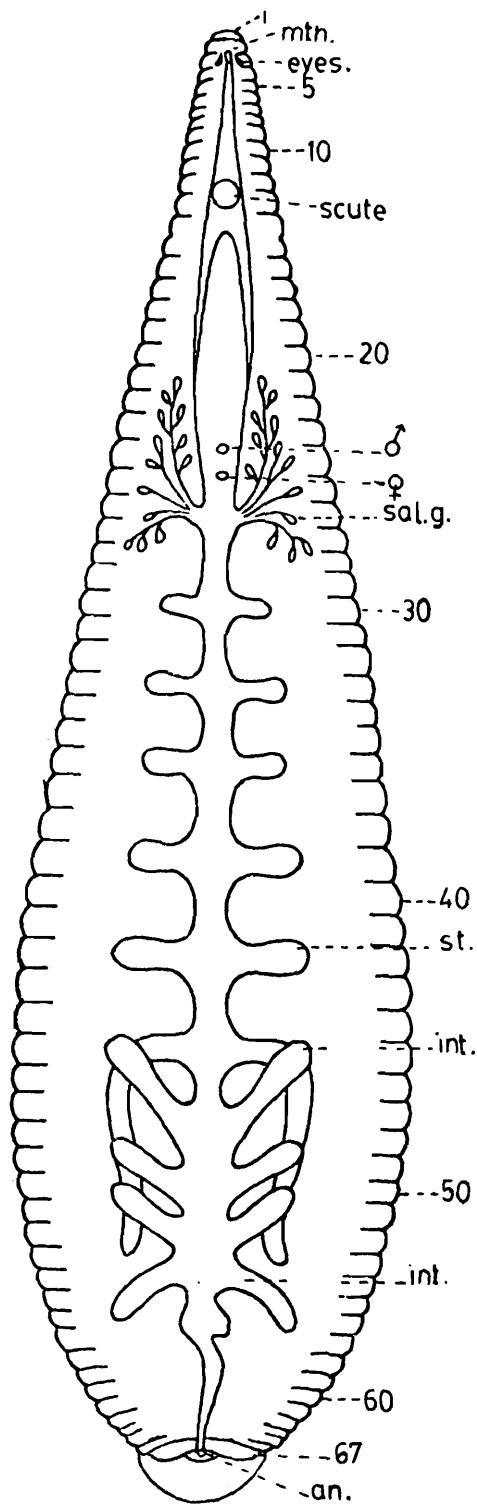

Fig.19.

Fig. 19. *Helobdella stagnalis* (Linnaeus, 1758). Diagram showing alimentary tract. *mth.*, mouth-opening; *prb.*, proboscis; *sal.g.*, salivary gland; *cr.*, crop; *st.*, stomach; *int.*, intestine; *an.*, anus. (After Harding).

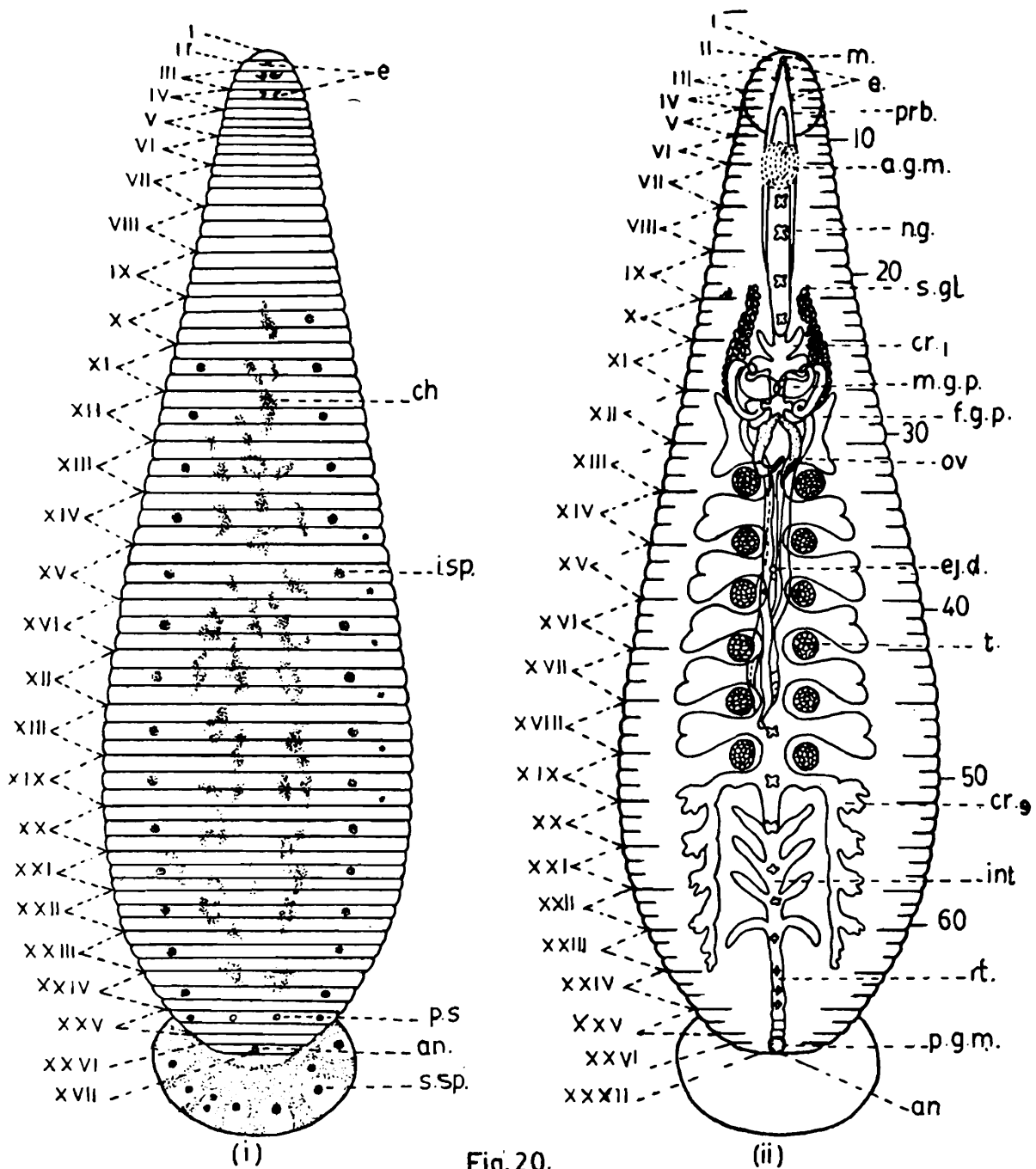

Fig. 20.

Fig. 20. *Hemiclepsia bhatiai* (Baugh, 1960). (i) Diagram showing the annulation and pigment spots. (ii) Diagram showing the alimentary canal and reproductive organs. *a.g.m.*, anterior ganglionic mass; *an.*, anus; *ch.*, chromatophore; *cr.1-cr.9*, nine pairs of crop caeca; *e.*, eyes; *ej.d.*, ejaculatory duct; *f.g.p.*, female genital pore; *int.*, intestine; *i.sp.*, intermediate series of spots; *m.*, mouth; *m.g.p.*, male genital pore; *n.g.*, nerve ganglion; *ov.*, ovisacs; *t.*, testis-sac; *prb.*, proboscis; *p.g.m.*, posterior ganglionic mass; *rt.*, rectum; *s.gl.*, salivary gland; *p.s.* paramedian spots on the posterior end of the body; *s.sp.*, supra marginal spots on the the posterior sucker. Somites numbered in Roman numerals. (After Baugh).

spots are visible. Total number of rings 70. The crop-stomach has nine pairs of caeca. (Fig. 20).

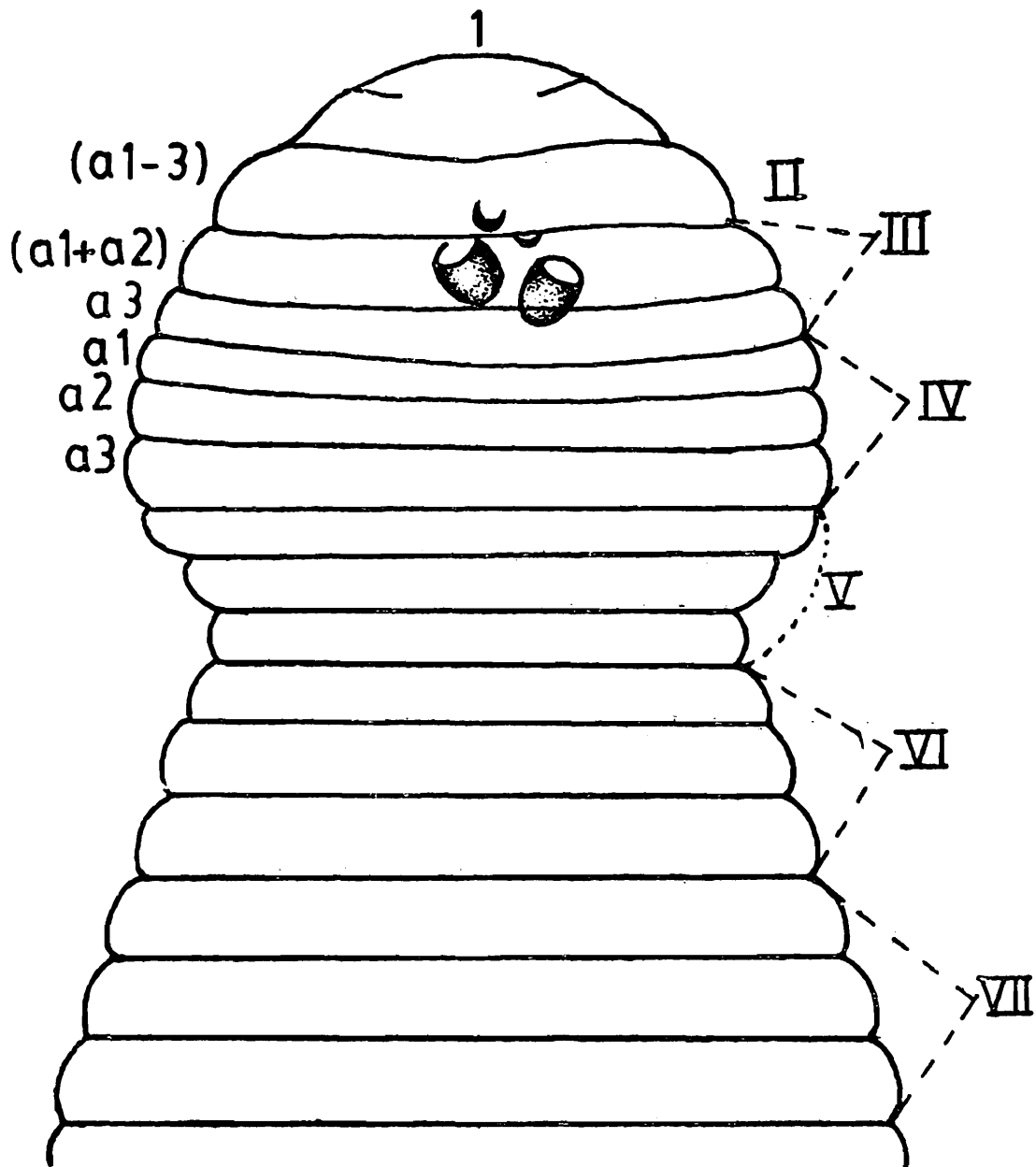

Fig.21.

Fig. 21. *Hemiclesis marginata asiatica* (Moore, 1924). Diagram showing dorsal view of head-region indicating eyes and annulation. Somites numbered in Roman and rings in ordinary figures. (After Moore).

Distribution : India : Kalipahar, Monghyr (Bihar) ; Kathua, Jammu (Jammu and Kashmir).

Field observation : The species can be found in pools.

Host not recorded so far. The specimens remain attached to submerged articles.

Hemiclepsis marginata asiatica Moore

1924. *Hemiclepsis marginata asiatica* Moore, *Proc. Acad. nat. Sci. Philad.*, 76 : 343-368. (Type-Locality : Srinagar ; Type-Deposited : Z S.I.).
 1983. *Hemiclepsis marginata asiatica*, Chandra, *Rec. zool. Surv. India*, 80 : 278.

Diagnostic characters : In this species the first pair of eyes are closely approximated and so minute that they may easily escape observation. They generally lie immediately in front of the conspicuous and more widely separated posterior pair of eyes. In some cases they may be in contact with the posterior pair of eyes and even apparently obliterated. The annulation in *asiatica* is considerably reduced. The colour in alcohol reddish-brown, paler towards the extremities. (Fig. 21).

Distribution : India : Srinagar (Jammu and Kashmir) ; Sirmour (Himachal Pradesh).

Field observation : The species is found in the slow moving hill streams ; attached to submerged articles. Median longitudinal yellow stripe and continuous yellow transverse stripes.

Hemiclepsis marginata marginata Muller

1774. *Hirudo marginata* Muller, *Vermium terrestrium et fluviatilium*, 1, pars 2.4°. Havinae et Lipsiae.
 1927. *Hemiclepsis marginata marginata*, Harding, *Fauna Brit. India*, Hirudinea, 83-86.
 1983. *Hemiclepsis marginata marginata*, Chandra, *Rec. zool. Surv. India*, 80 : 279.

Diagnostic characters : The flattened claviform and translucent body is richly pigmented. Dorsal surface with seven longitudinal rows of lemon-yellow spots. Total number of rings 72. Two pairs of eyes are situated respectively

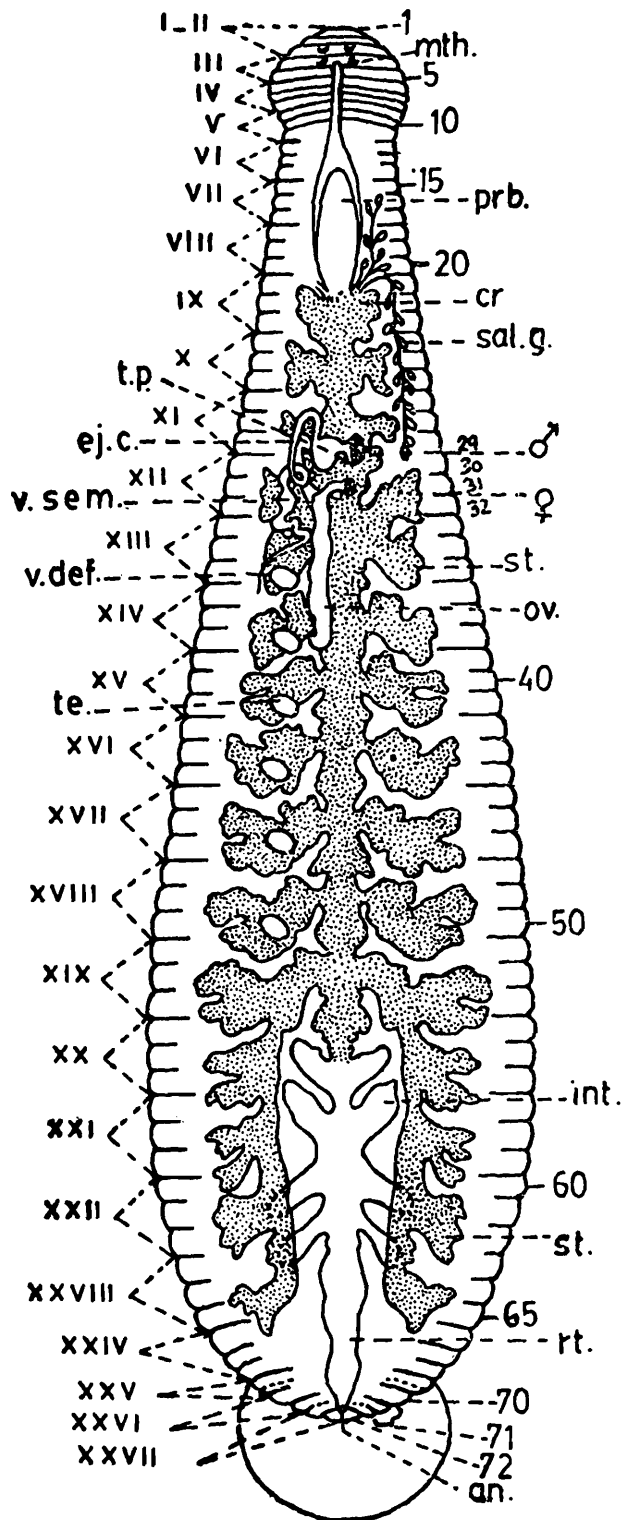

Fig.22.

Fig. 22. *Hemiclepsis marginata marginata* (Muller, 1774). Diagram showing alimentary tract and reproductive organs. The latter, and also the salivary glands, are shown on one side only for the sake of clearness. *mth.*, mouth; *prb.*, proboscis; *sal.g.*, salivary glands; *st.*, stomach (Shaded); *int.*, intestine; *rt.*, rectum; *an.*, anus; *ej.c.*, ejaculatory canal; *t.p.*, its terminal portion; *v.semi.*, vesicula seminalis or seminal reservoir; *v.def.*, vas deferens; *te.*, testes; *ov.*, ovary. (After Harding).

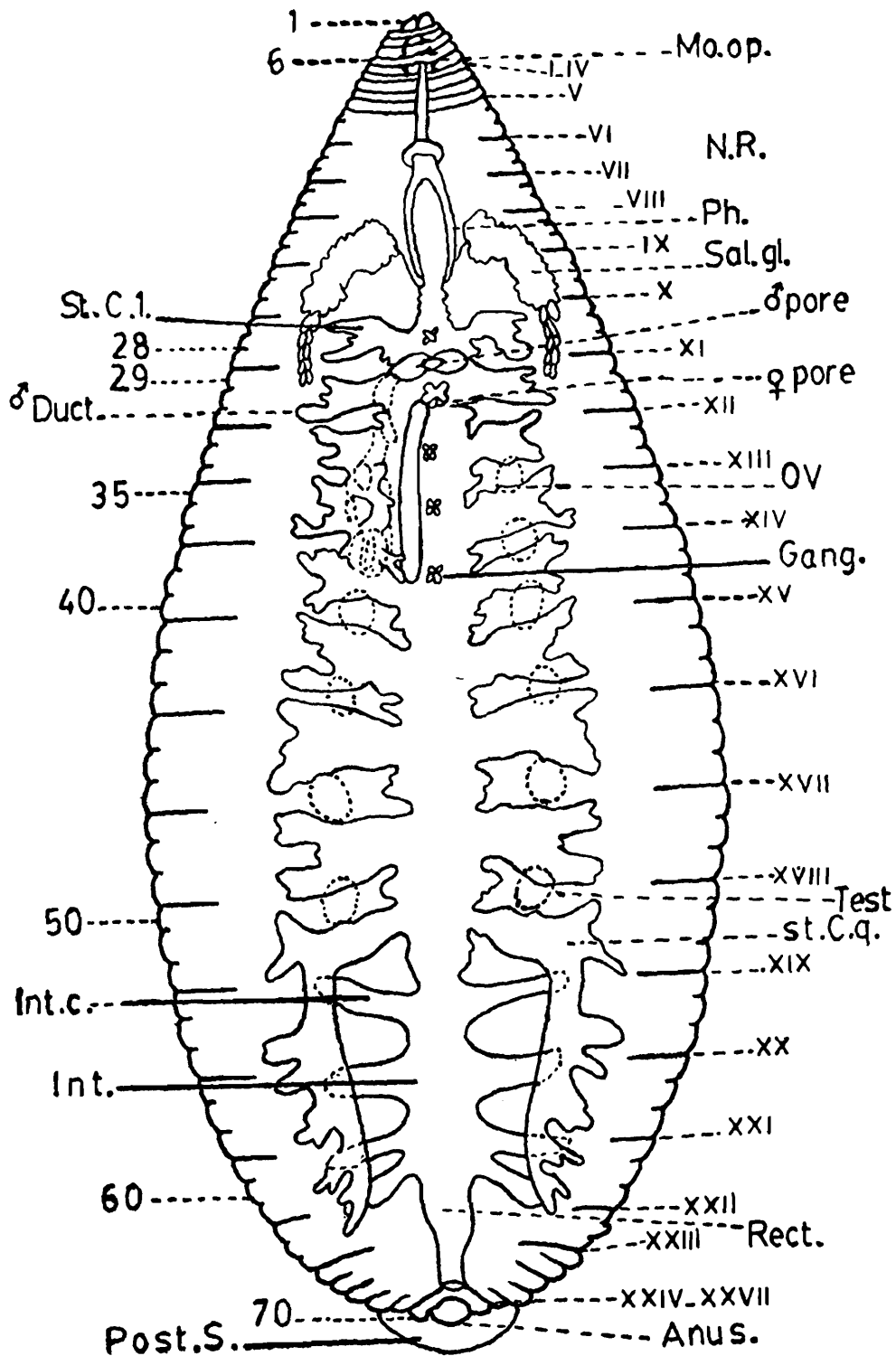

Fig. 23.

Fig. 23. Annulation and internal structure of *Hemiclepsis viridis* (Chelladurai, 1934). 1 to 71 : annuli ; I to XXVII : somites ; *Gang.*, ganglion ; *int.*, intestine ; *int.c.*, intestinal caecum ; *Mo.op.*, mouth-opening ; *N.R.*, nervous ring ; *Ov.*, ovary ; *Ph.*, pharynx ; *Post.s.*, posterior sucker ; *Rect.*, rectum ; *St.C.1.*, first stomach caecum ; *St.C.9.*, ninth stomach caecum ; *Sal.gl.*, salivary gland ; *Test.*, testes. (After Chelladurai).

on ring three and four. The male genital pore opens between ring 29 and 30. (Fig. 22).

Distribution : India ; Kumaon (Uttar Pradesh) ; Murshidabad (West Bengal) ; Jodhpur (Rajasthan) ; Igatpuri, Satara (Maharashtra) ; Hoshangabad (Madhya Pradesh) ; Jammu, Poonch (Jammu and Kashmir). Outside India : Europe, Western Asia and Nepal.

Field observation : The species is generally found in ponds, streams and lakes. It is chiefly a fish parasite, but it also attacks certain molluscs. They are also found free-living or attached to submerged articles.

Hemiclepsis viridis Chelladurai

1934. *Hemiclepsis viridis* Chelladurai, *Rec. India Mus.*, 36 : 345-352.
(Type-Locality : Trivandrum, Kerala ; Type-Deposited : Z.S.I.).
1983. *Hemiclepsis viridis*, Chandra, *Rec. zool. Surv. India*, 80 : 279.

Diagnostic characters : The body at rest is ovate-lanceolate, head is faintly dilated. The colouration is characteristic of the species. The dorsal surface bears fifteen to twenty five bright pea-green longitudinal subparallel lines, they are composed of numerous close-set pigment spots. Three pairs of eyes in two sub-parallel rows on rings 3, 4 and 6. Mouth opening within the oral sucker. The stomach has nine pairs of lobed caeca. (Fig. 23).

Distribution : India : Trivandrum (Kerala) and Ootacamund.

Field observation : It is found in tanks and pools. The specimens can be collected from the aquatic vegetation to which they attach themselves undersurface.

Genus : Paraclepsis Harding

1924. *Paraclepsis* Harding, *Ann. & Mag. Nat. Hist. Ser. 9*, 14 : 489.

The species of this genus are of medium size with three pairs of eyes. First and second pairs on consecutive rings and third pair separated by two rings. Complete somite formed of three rings. Mouth-opening subterminal, leaving

the anterior sucker imperforate. The crop (or stomach) has more than seven pairs of lateral diverticula.

Paraclepsis praedatrix Harding

1924. *Paraclepsis praedatrix* Harding, *Ann. & Mag. Nat. Hist.*, Ser. 9, 14 : 489. (Type-Locality and Type-Deposited : Not known).

1983. *Paraclepsis praedatrix*, Chandra, *Rec. zool. Surv. India*, 80 : 279.

Diagnostic characters : The ovate-acuminate body is smooth below, and a roughened dorsal surface due to numerous small papillae closely set on every ring. The head-region is separated from the rest of the body by a slight constriction. Total number of rings 73. Three pairs of eyes are disposed in two sub-parallel rows in rings 3, 4 and 7. Male gonopore between ring 29 and 30. (Fig. 24).

Distribution : Sirmour, Solan and Bilaspur (Himachal Pradesh) ; Kalka (Haryana), Purulia, Chhota Nagpur (Bihar) ; Mangaldai (Assam) ; Jodhpur, Nagaur, Jaisalmer, Jaipur, Bikaner, Sikar (Rajasthan) ; Igatpuri, Kolhapur, Satara (Maharashtra) ; Kathua, Jammu, Udhampur, Poonch (Jammu and Kashmir).

Field observation : The specimens can be collected from lakes, tanks, pools and small streams. They are found free-living or attached to submerged articles.

Paraclepsis vulnifera Harding

1924. *Paraclepsis vulnifera*, Harding, *Ann. Mag. nat. Hist.*, Ser. 9, 14 : 489. (Type-Locality : Tanjore, Tamil Nadu ; Type-Deposited : Not known).

1983. *Paraclepsis vulnifera*, Chandra, *Rec. zool. Surv. India*, 80 : 280.

Diagnostic characters : Body ovate-acuminate, with a somewhat roughened dorsal surface due to presence of numerous small papillae on every ring. Head-region continuous with the body. Total number of rings 70. The three pairs of eyes are disposed in two subparallel rows. 1st pair in the anterior part of ring 2 and 2nd pair in the

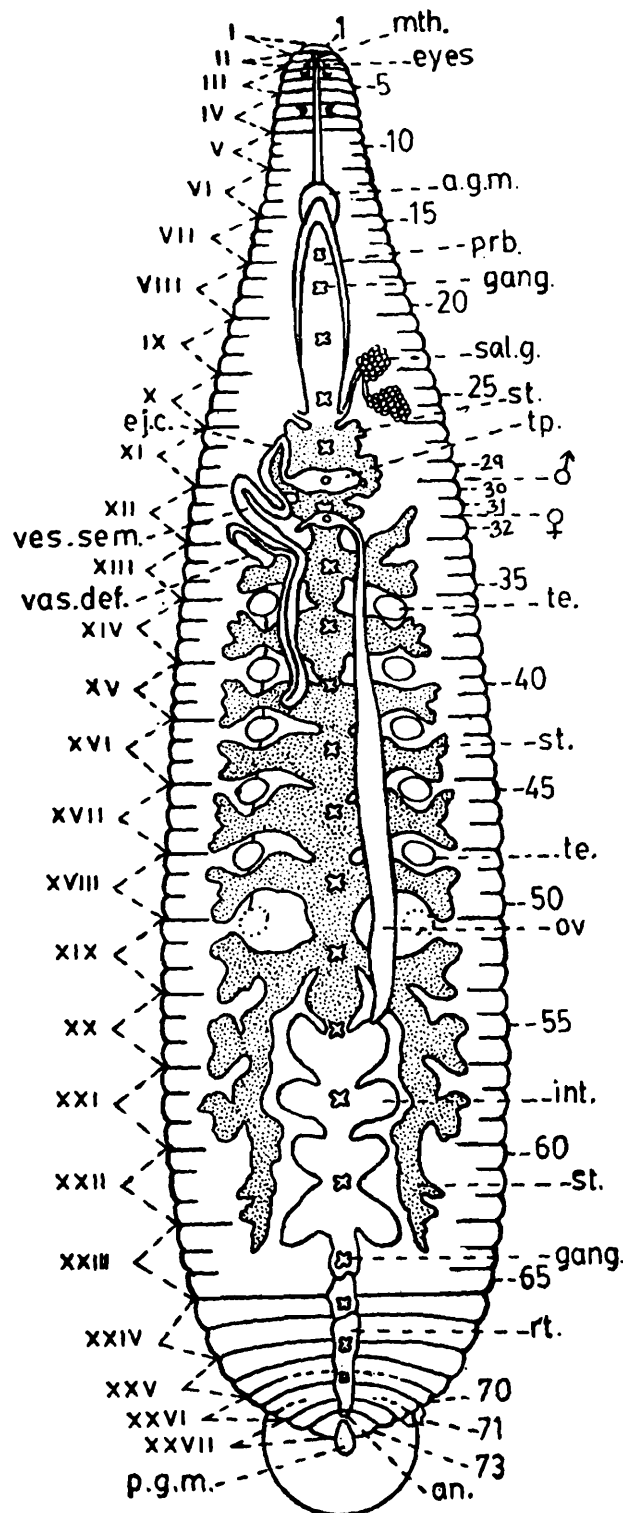

Fig. 24.

Fig. 24. *Paraclepsis praedatrix* (Harding, 1924). Diagram showing external features, reproductive system, alimentary tract and ventral nerve ganglia. Some of the paired organs are shown on one side only, in order to obtain clearness. Somites numbered in Roman and rings in ordinary figures. *mth.*, mouth-opening; *prb.*, proboscis; *sal.g.*, salivary glands; *st.*, stomach; *int.*, intestine; *rt.*, rectum; *an.*, anus; *ej.c.*, ejaculatory canal; *t.p.*, its terminal portion; *ves.sem.*, vesicula seminalis or seminal reservoir; *vas.def.*, vas deferens; *te.*, testes; *a.g.m.*, anterior ganglionic mass; *p.g.m.*, posterior ganglionic mass; *gang.*, a gangon of the ventral chain. (After Harding).

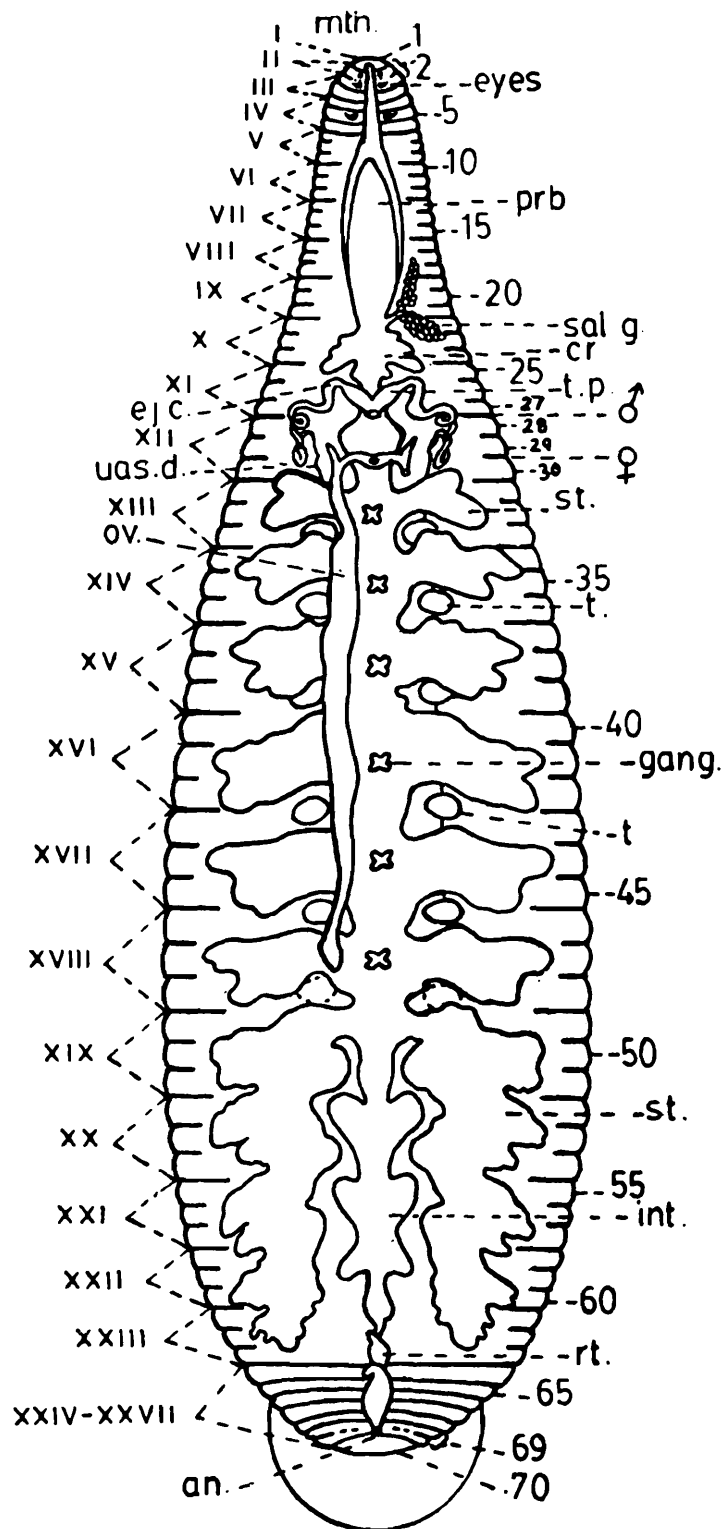

Fig. 25.

Fig. 25. *Paraclepsis vulnifera* (Harding, 1924). Diagram showing external features, reproductive system and alimentary tract. Somites numbered in Roman and rings in ordinary figures. *mth.*, mouth-opening; *prb.*, proboscis; *sal.g.*, salivary glands; *st.*, stomach; *rt.*, rectum; *an.*, anus; *ej.c.*, ejaculatory canal; *vas.d.*, vas deferens; *ov.*, ovary (only one ovary is shown for the sake of clearness); *gang.*, a ganglion of the ventral chain. (After Harding).

posterior part of ring 2. The third pair of eyes lie in ring 5. Male gonopore in between ring 27 and 28. (Fig. 25).

Distribution : India : Bilaspur (Himachal Pradesh) ; Nagaur, Bikaner (Rajasthan) ; Satara (Maharashtra) ; Tanjore (Tamil Nadu) ; Jammu (Jammu and Kashmir).

Field observation : Tanks, pools, streams ; they can be collected in the free-living form or attached to submerged articles. Sometimes ectoparasitic on crabs.

Genus : **Placobdella** Blanchard

1893. *Placobdella* Blanchard, *Bull. Soc. Zool. France*, 17 : 93.

Body flattened, with a crustaceous dorsal surface and sometimes attaining considerable size. Complete somite formed of three rings. Anterior sucker imperforate, the mouth opening being situated upon its anterior rim. Usually one pair of eyes. Crop (or stomach) with seven pairs of branching diverticula. Parasitic chiefly upon turtles, batrachians and fish.

Placobdella ceylanica (Harding)

1909. *Glossiphonia ceylanica* Harding, *Proc. Camb. Phil. Soc.*, 15 : 233. (Type-Locality : Sri Lanka, Type-Deposited : Not known).

1983. *Placobdella ceylanica*, Chandra, *Rec. zool. Surv. India*, 80 : 276.

Diagnostic characters : Body lanceolate, smooth, flattened, with head region slightly dilated. Posterior sucker small, its diameter being equal to about half the greatest width of the body. Dorsal surface with three longitudinal dark brown lines or rows of spots. Total number of rings 71. Six eyes disposed in two subparallel rows lying in rings 3,4 and 6. Crop with seven pairs of caeca.

Distribution : India : Buldana (Madhya Pradesh) ; Chilka lake (Orissa).

Outside India : Pakistan and Sri Lanka.

Field observation : Found in lakes and tanks, parasitic on molluscs, frogs and turtles.

Placobdella emydae Harding

1920. *Placobdella emydae* Harding, *Mem. Indian Mus.*, 5 : 510. (Type-Locality and Type-Deposited : Not known).

1983. *Placobdella emydae*, Chandra, *Rec. zool. Surv. India*, 80 : 277.

Diagnostic characters : Body flattened, elliptic-lanceolate in extension ; with the head-region somewhat dilated. Metameric papillae is present on the middle ring of the somite dorsally, paramedian, intermediate and paramarginal pairs, the intermediate pair being the largest. Posterior sucker circular, centrally attached, narrower than the widest part of the body, upper surface bearing paired white rays. Total number of rings 71. The single pair of eyes usually lies in ring three, but sometimes appear between ring 2 and 3. (Fig. 26).

Distribution : India : Solan (Himachal Pradesh) ; Chhota Nagpur (Bihar) ; Calcutta, Hooghly (West Bengal) ; Sambalpur, Chilka lake (Orissa) ; Hoshangabad, Nagpur, Satara (Maharashtra).

Outside India : Burma.

Field observation : Free-living, attached to submerged articles in lakes, tanks and pools. Parasitic on turtles.

Placobdella fulva Harding

1924. *Placobdella fulva* Harding, *Ann. Mag. nat. Hist. Ser. 9*, 14 : 489. (Type-Locality and Type-Deposited : Not known).

1983. *Placobdella fulva*, Chandra, *Rec. zool. Surv. India*, 80 : 277.

Diagnostic characters : Body flattened, in extension claviform and very slender anteriorly. Upper surface of a bright reddish-yellow hue, ventral surface white. On the dorsal surface of the middle ring of each somite are covered by deep brown spots, which are longitudinally connected by dark brown lines. Head-region undilated and continuous with the body. Posterior sucker small, centrally attached, not wider than half the greatest width of the body, with paired

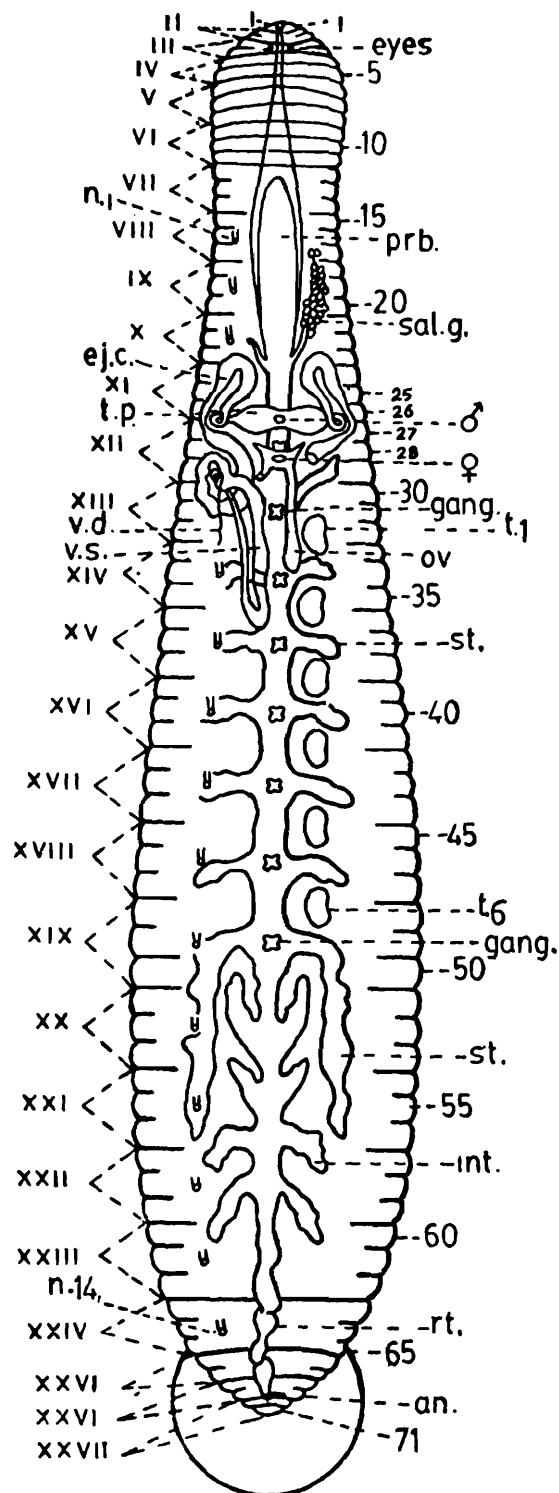

Fig. 26.

Fig. 26. *Placobdella emydae* (Harding, 1920). Diagram showing external and internal feature. Somites numbered in Roman and rings in ordinary figures. *prb.*, proboscis; *sal.g.*, salivary glands; *ej.c.*, ejaculatory canal; *t.p.*, terminal portion of reservoir; *v.d.*, vas deferens; *gang.*, ventral ganglion; *st.*, stomach; *rt.*, rectum; *an.*, anus; *n.1*, *n.14*, first and fourteenth pair of nephridiopores (on ventral surface). (After Harding).

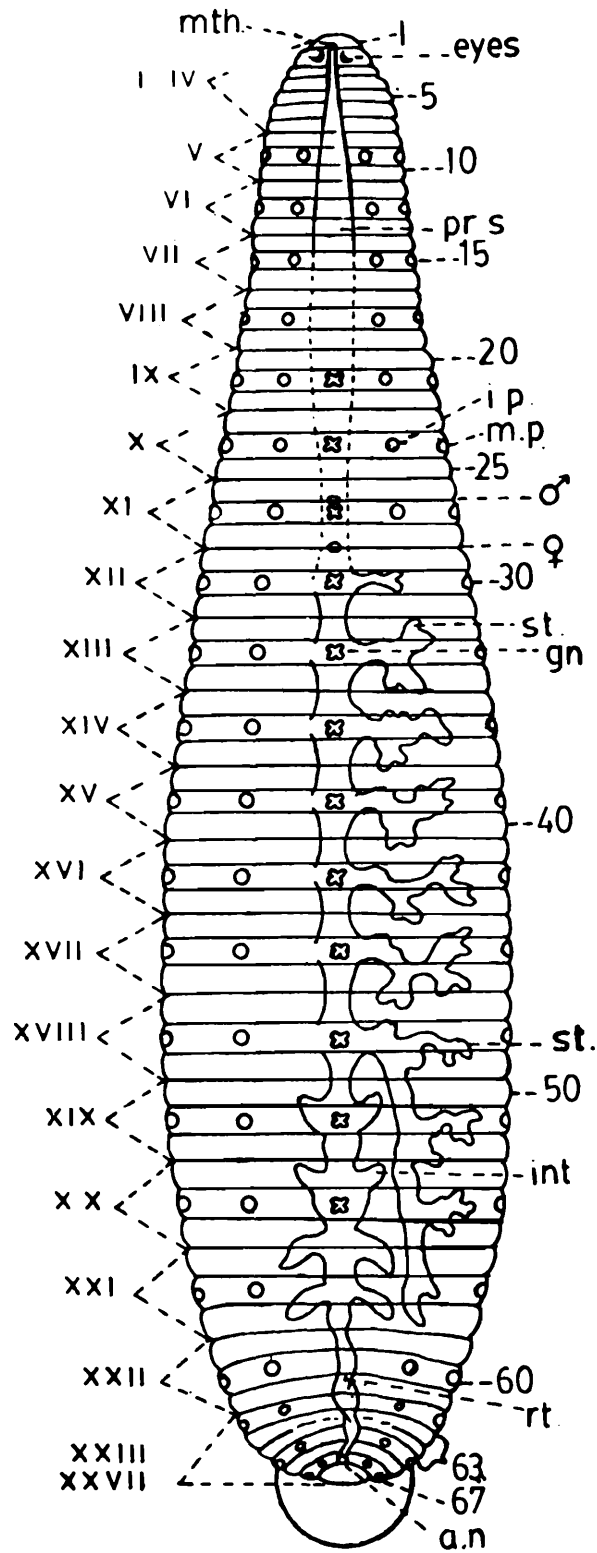

Fig. 27.

Fig. 27. *Placobdella fulva* (Harding, 1924). Diagram showing external features, digestive tract and nerve ganglion. Somites numbered in Roman and rings in ordinary figures. *i.p.*, intermediate papilla; *m.p.*, marginal papilla; *mth.*, mouth; *prs.*, proboscis sheath; *st.*, stomach; *int.*, intestine; *rt.*, rectum; *an.*, anus; *gn.*, a ganglion of the ventral chain. (After Harding).

cream coloured rays. Total number of rings 67. The single pair of eyes lie within ring 2. (Fig. 27).

Distribution : India : Chhota Nagpur, Manbhum (Bihar) ; Kathua, (Jammu and Kashmir).

Field observation : Free-living and parasitic on molluscs. Attached to submerged articles in lakes, tanks, pools and streams.

Placobdella horai Baugh

1960. *Placobdella horai* Baugh, *Parasitology*, 50 : 287-310. (Type-Locality : Purulia, Bihar ; Type-Deposited : Z.S.I.).

1983. *Placobdella horai*, Chandra, *Rec. zool. Surv. India*, 80 : 277.

Diagnostic characters : Body is thick, flattened, ovate-acuminate shape. Dorsal side studded with numerous small, closely set papillae. A pair of small cup-shaped eyes in ring 2. The posterior sucker is circular, centrally attached, its diameter is approximately half the maximum width of the body. The body is profusely pigmented which masks much of the internal characters. The median longitudinal band of lemon-yellow colour runs from the posterior to the anterior end of the body which gradually narrows down. On each side of this band are present two series of dark-brown spots. Total number of rings 66. (Fig. 28).

Distribution : India : Purulia, Manbhum (Bihar).

Field observation : Found in lakes, parasitic on prawn *Palaemon lamarrei* H. M.

Placobdella indica Baugh

1960. *Placobdella indica* Baugh, *Zool. Anz.*, 165 : 468-477. (Type-Locality : Sitkundi, Monghyr, Bihar ; Type-Deposited : Z.S.I.).

1983. *Placobdella indica*, Chandra, *Rec. zool. Surv. India*, 80 : 277.

Diagnostic characters : The body is elongated, dorsoventrally flattened and typically elliptic-lanceolate in shape. Two closely apposed cup-shaped eyes are present in ring 3. Male gonopore between ring 25 and 26. Total number of rings 70. The crop-stomach has seven pairs of branched caeca. The posterior sucker is about three-fourths of the maximum

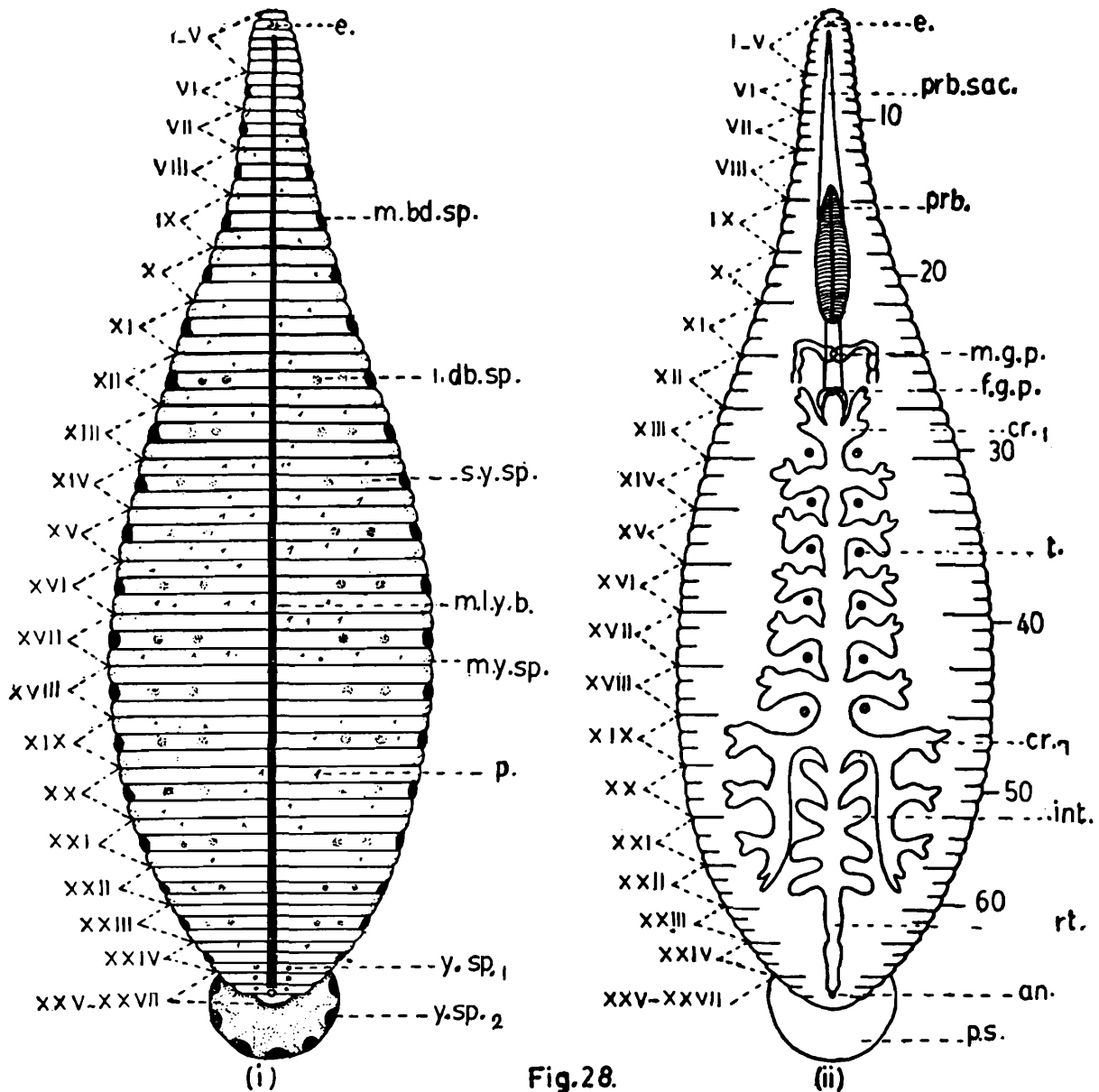

Fig.28.

Fig. 28. *Placobdella horai* (Baugh, 1960). (i) Diagram showing the annulation and metameric spots. (ii) Diagram showing the alimentary canal and reproductive organs. *an.*, anus; *cr.1-cr.7*, seven pairs of crop caeca; *e.*, eyes; *f.g.p.*, female genital pore; *int.*, intestine; *i.db.sp.*, intermediate dark-brown spot; *m.db.sp.*, marginal dark-brown spot; *m.g.p.*, male genital pore; *m.l.y.b.*, median longitudinal yellow band; *m.y.sp.*, marginal yellow spot; *p.*, papillae; *prb.*, proboscis; *prb.sac.*, proboscis-sac; *p.s.*, posterior sucker; *rt.*, rectum; *s.y.sp.*, supramarginal yellow spot; *y.sp.*, yellow spots at the broad end of the longitudinal band; *y.sp.2*, yellow spots upon the posterior sucker. Somites numbered in Roman numerals.

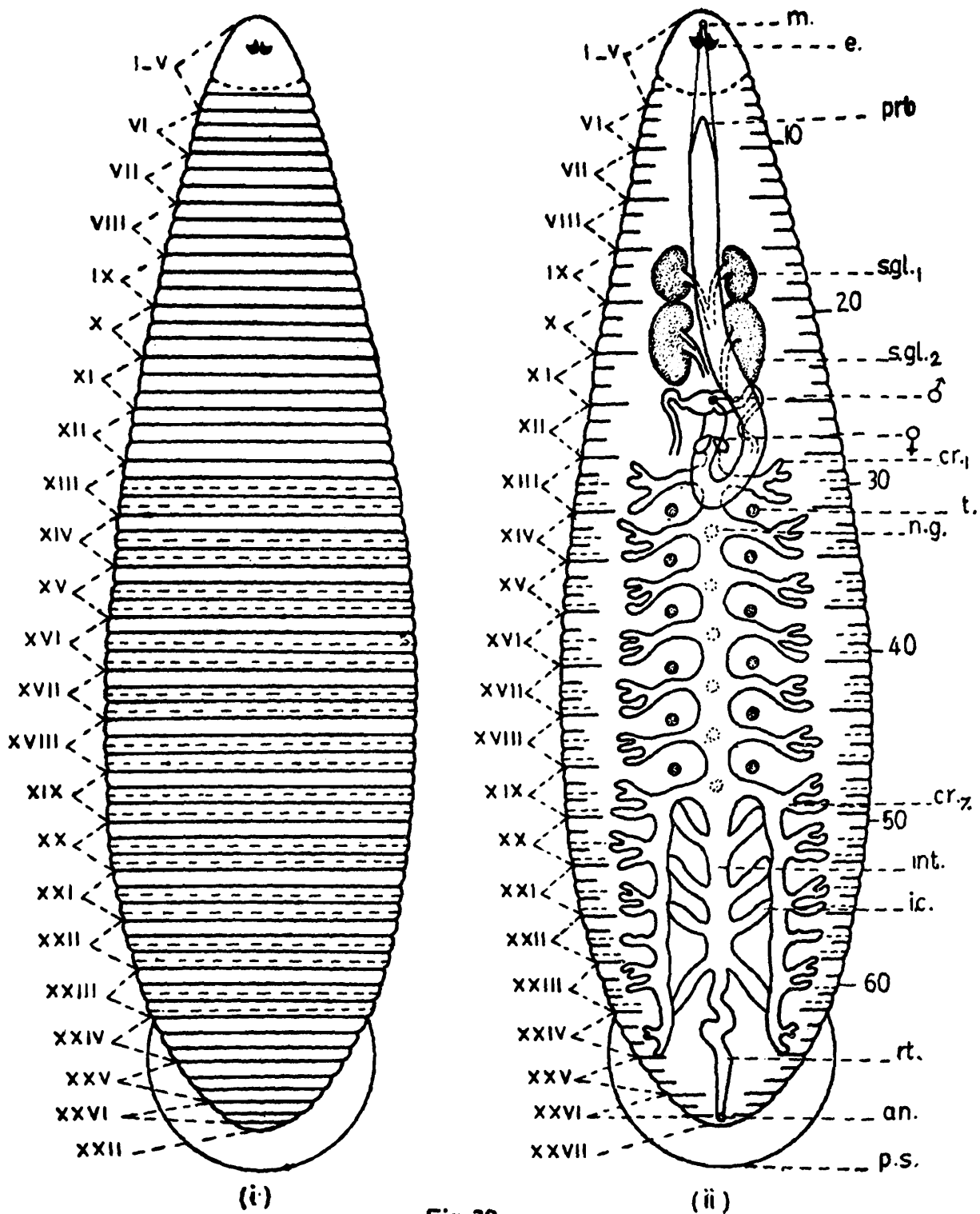

Fig 29.

Fig. 29. *Placobdella indica* (Baugh, 1960). (i) Diagram showing annulation. (ii) Diagram showing alimentary canal and reproductive organs. *an.*, anus; *cr.1-cr.7*, seven pairs of crop caeca; *e.*, eyes; *int.*, intestine; *i.c.*, intestinal caeca; *m.*, mouth; *n.g.*, nerve ganglion; *prb.*, proboscis; *p.s.*, posterior sucker; *rt.*, rectum; *s.gl.1*, and *s.gl.2*, two pairs of salivary gland; *t.*, testis sac. Somites numbered in Roman figures. (After Baugh).

width of the body. A number of longitudinal stripes of light yellowish-brown are present on the dorsal surface of the body. The annuli a2 and a3 in the somite from XIII to XXIII show subdivision into secondary rings. The primary annuli (a2 and a3) are split up into two rings each, of which anterior one is wider than the posterior one. The annular receptors are confined to the broader anterior ring. (Fig. 29).

Distribution : India : Monghyr (Bihar) ; Kathua (Jammu and Kashmir).

Field observation : Pools, tanks, free-living and attached to submerged articles.

Placobdella undulata Harding

1924. *Placobdella undulata* Harding, *Ann. Mag. nat. Hist. Ser. 9, 14* : 489. (Type-Locality and Type-Deposited : Not known).

1983. *Placobdella undulata*, Chandra, *Rec. zool. Surv. India, 80* : 277.

Diagnostic characters : The typical elliptic lanceolate form of the body is modified in adult individuals by a slight constriction centred at the thirtieth ring, immediately behind the female orifice. Dorsal surface with a roughened appearance due to numerous closely-set papillae on each ring. Head-region somewhat dilated and distinct from body. Posterior sucker circular or slightly oval, small, centrally attached. Total number of rings 71. The single pair of eyes lie in ring two. The seven pairs of gastric caeca are moderately lobate. (Fig. 30).

Distribution : India : Jodhpur (Rajasthan) ; Solan (Himachal Pradesh) ; Kathua (Jammu and Kashmir).

Outside India : Sri Lanka.

Field observation : It is found in tanks, pools and lakes, free-living or attached to submerged articles and parasitic on fish.

Genus : **Theromyzon** Philippi

1867. *Theromyzon* Philippi, Kurze Notiz uber zwei chilenische Blutegel. *Arch. f. Naturg.*, 1 : 76-78.

These are generally elongated, soft, delicate, somewhat

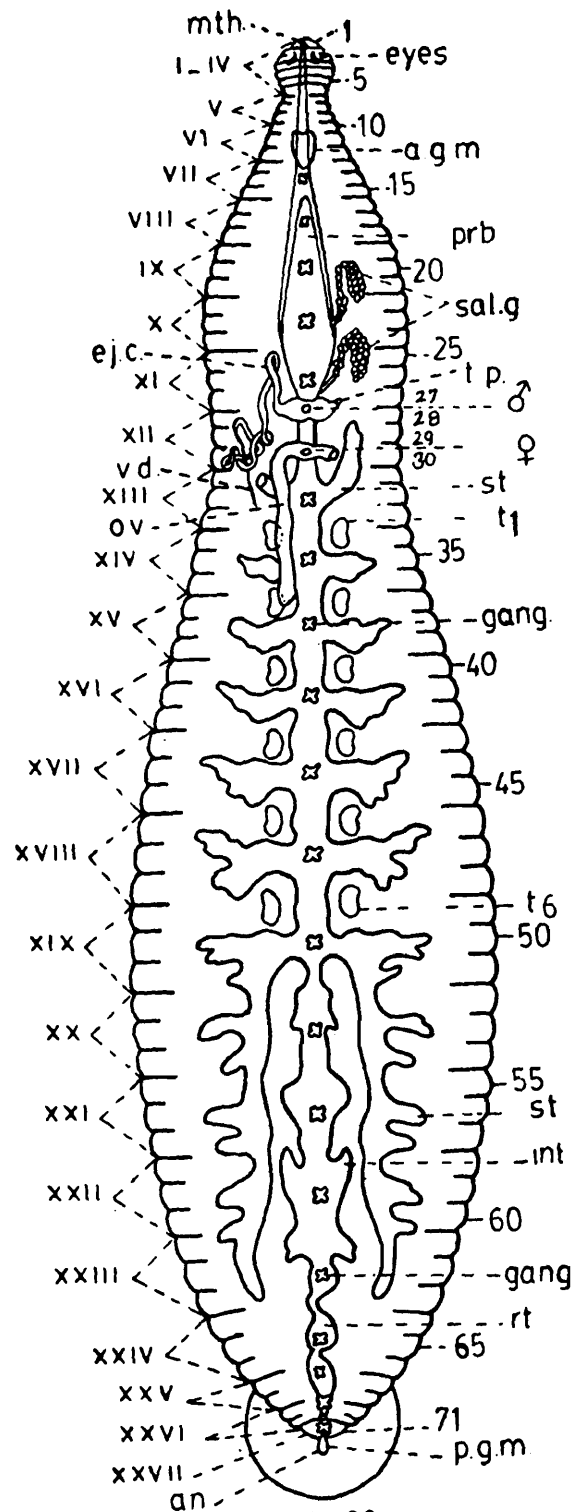

Fig. 30

Fig. 30. *Placobdella undulata* (Harding, 1924). Diagram showing external features, reproductive system, alimentary tract and nerve ganglia. Somites numbered in Roman and rings in ordinary figures. *mth.*, mouth; *prb.*, proboscis; *sal.g.*, salivary glands; *st.*, stomach; *int.*, intestine; *rt.*, rectum; *an.*, anus; *ej.c.*, ejaculatory canal (shown only on one side for the sake of clearness); *t.p.*, terminal portion of ejaculatory canal; *v.d.*, vas deferens; *t.1-t.6*, first and sixth pair of testes; *ov.*, one of the ovaries; *a.g.m.*, anterior ganglionic mass; *p.g.m.*, posterior ganglionic mass; *gang.*, a ganglion of the ventral chain. (After Harding).

flattened leeches. More or less of greyish-green or brown colour, with yellow spots upon the upper surface of the body and also of the posterior sucker, where they are disposed in marginal series. They are of a medium size with four pairs of eyes. The crop has more than seven pairs of lateral diverticula. Most of the species known have been found in lake Baikal, Siberia.

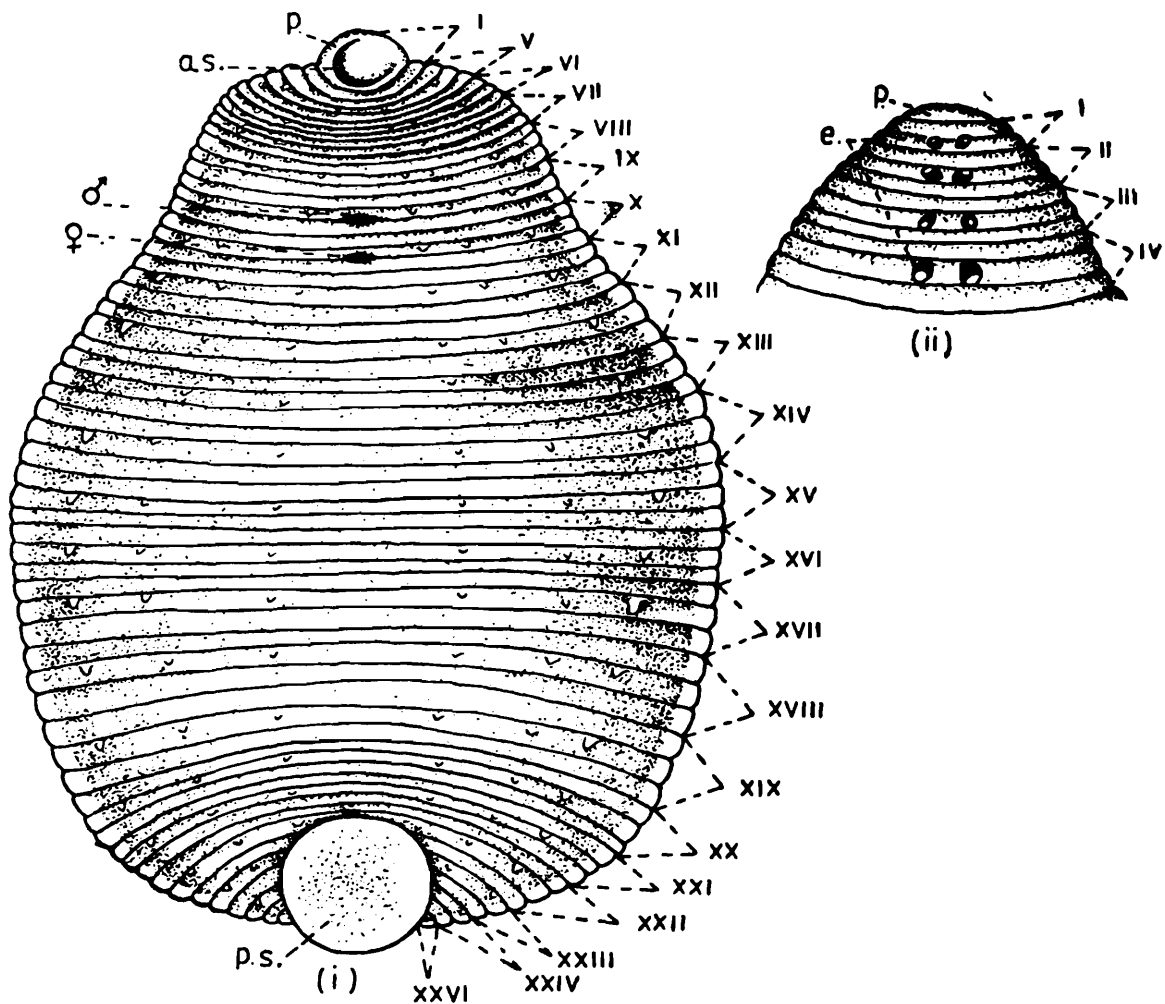

Fig. 31.

Fig. 31. *Theromyzon mathai* (Bhatia, 1939). (i) Ventral aspects, showing the external features, and (ii) Diagrammatic representation of the anterior part of the dorsal surface. Somites are numbered in Roman numerals. a.s., anterior sucker; e., four pairs of eyes; p., prostomium; p.s., posterior sucker; X a2/a3, male genital pore; XI a2/a3, female genital pore.

***Theromyzon mathaii* Bhatia**

1939. *Theromyzon mathaii* Bhatia, *Bull. Punj. Univ. Zool.*, 2 : 1-17. (Type Locality : Srinagar, Jammu and Kashmir ; Type-Deposited : Not known).
1983. *Theromyzon mathaii*, Chandra, *Rec. zool. Surv. India*, 80 : 278.

Diagnostic characters : The body is heart-shaped, broad and foliaceous, flattened and transparent. It has a slightly convex dorsal surface. Complete somite is of three rings. Eyes four pairs on the dorsal surface in the inner para-median line. They are in two closely placed parallel rows on rings 2, 5, 8 and 11. The head region is not enlarged, anterior sucker is small and posterior sucker is well formed. There are longitudinal rows of spots. The alimentary tract consists of 11 pairs of lateral diverticula. Gonopores separated by three annuli. (Fig. 31).

Distribution : India : Srinagar (Jammu and Kashmir).

Field observation : The species is found in lakes. Young ones attach to the ventral side of the parent body. Can be found among the aquatic vegetation.

***Theromyzon sexoculata* (Moore)**

1898. *Proclepsine sexoculata* Moore. *Proc. U.S. Nat. Mus.*, 21(1160) : 543-563. (Type-Locality and Type-Deposited : Not known).
1927. *Theromyzon sexoculata*, Harding, *Fauna Brit. India*, Hirudinea ; 82-83.
1983. *Theromyzon sexoculata*, Chandra, *Rec. zool. Surv. India*, 80 : 278.

Diagnostic characters : The species has an elongate slender body, convex above and flattened below, and of an olive green colour. The dorsal surface is traversed by six longitudinal rows of yellow spots. Total number of rings 74. Eyes four pairs forming two subparallel rows and situated on rings 2, 4, 7 and 10. (Fig. 32).

Distribution : India : Loktak lake (Manipur State).
Outside India : Siberia (Russia) ; France and Sweden.

Field observation : The species is generally found in lakes, they attack wild-Duck and other water-fowls,

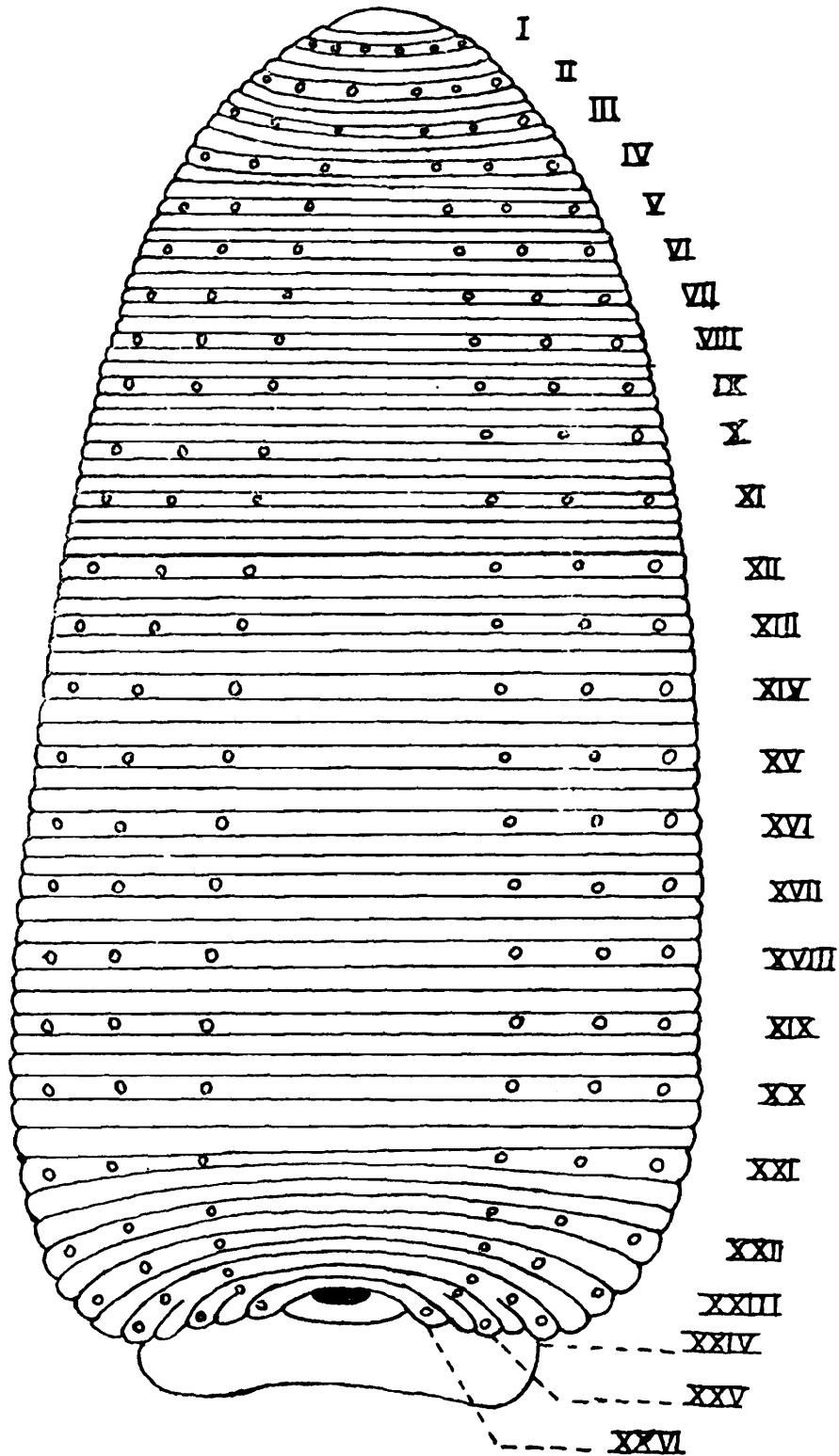

Fig. 32

Fig. 32. *Theromyzon sexoculata* (Moore, 1898). Diagram showing general morphology of dorsal surface. The segmentation and arrangement of the papillae as shown for all the somites,

Diagnostic Characters of : Order ARHYNCHOBDELLAE

Absence of protrusible proboscis, with jaws. Cephalic sucker scoop-shaped with a deep oral chamber, at the caudal end of which is the mouth. Blood red. Complete somites are usually five-ringed. Reproductive system complex, commonly with copulatory organs. In this order the leeches is said to have reached their complete and perfect expression. In size it varies from 2.5 cm to 30 cm or even 45 cm in length. But most of species fall within the limit of 5 cm to 15 cm.

The species of this order are fully adapted to sanguivorous or predaceous habit with a few exceptions. They are freshwater or terrestrial but no marine form known yet. In the order three families and 12 genera have been dealt with. (Fig. 33).

Key to the families of the order ARHYNCHOBDELLAE

- | | |
|---|----------------------|
| 1. Eyes never arranged in a regular arch of five pairs on contiguous somites of the head ; but varying in number and arrangement, or even absent. ... | <i>Erpobdellidae</i> |
| Eyes forming a regular arch on contiguous somites of the head ; nearly always five pairs. ... | 2 |
| 2. Third and fourth pairs of eyes separated by an annulus. ... | <i>Hirudidae</i> |
| Third and fourth pairs of eyes usually on contiguous annuli. ... | <i>Haemadipsidae</i> |

Diagnostic Characters of : Family ERPOBDELLIDAE

The worm-leeches are of small or medium size, and slender linear form possessing great powers of extension. They are terete or subterete anteriorly, becoming gradually more flattened towards the caudal end. Mouth over-arched by a prominently projecting lip. Caudal sucker also relatively small, little expanded disc directed ventrad and broadly attached by a slightly differentiated pedicel. Body very muscular, firm and slippery.

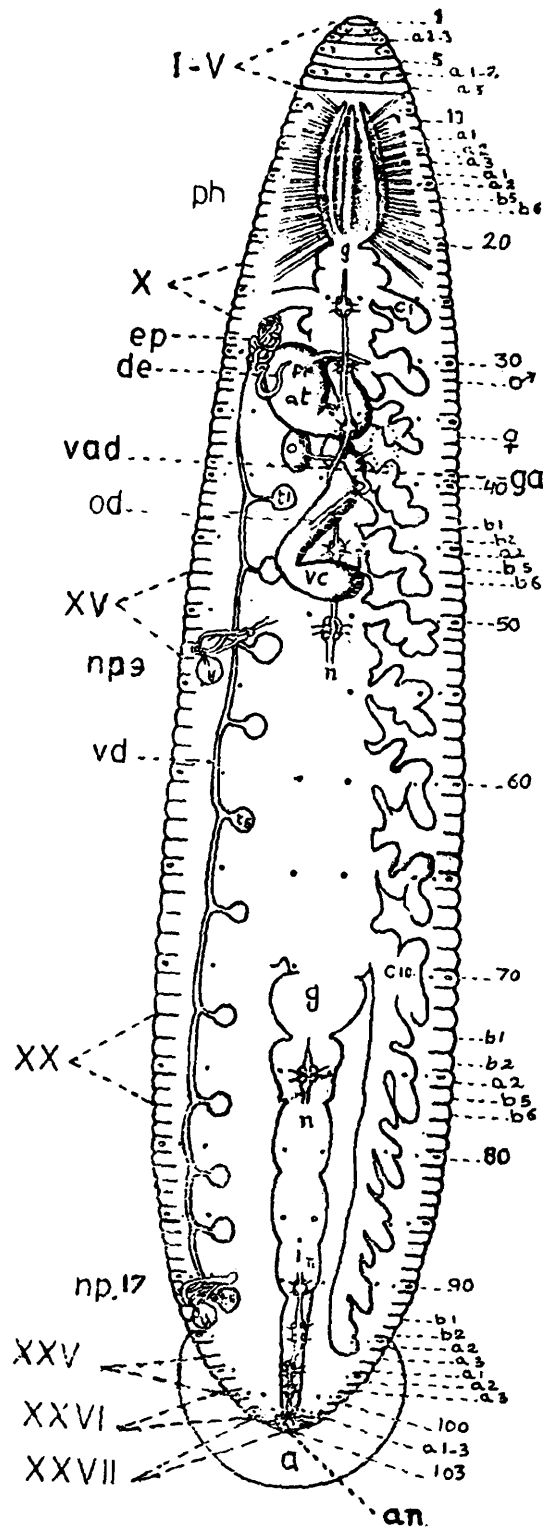

Fig. 33.

Fig. 33. Diagram of external metamerism and annulation of a typical ten-eyed leech, slightly modified from the drawing of the Harding and Moore (1927) based upon *Poecilobdella granulosa* (Savigny). Metamerism indicated on the left side by Roman numeral, annulation on the right side by Arabic. *a.*, anus; *at.*, atrium; *c.* 1-10, gastric caeca; *d.e.*, ductus ejaculatorius; *ep.*, epididymis; *g.*, stomach; *g.e.*, glandula albuminigenia; *i.*, intestine; *n.*, nerve cord with ganglia; *np.*, 9-17, nephridia; *o.*, ovary; *o.d.*, common oviduct; *ph.*, pharynx; *pr.*, prostate region of atrium; *p.s.*, penis-sac of atrium; *t.* I-II, testes; *v.a.d.*, vaginal duct; *v.c.*, vaginal caecum; *v.d.*, vas deferens. (After Harding and Moore).

Eyes usually in two groups, the more anterior (labial group) of one or two pairs close together on the dorsum of the lip and directed forward ; the posterior (buccal group) usually of two pairs of smaller eyes directed laterocauded on the side of the buccal ring. The latter, or even both groups, may be absent, or accessory eyes may be present in the dorsal paramedian and intermediate or the ventral submarginal series of the posterior cephalic and anterior post-cephalic somites.

Clitellum well developed, gonopores usually separated by less than five annuli, but may be two to seven annuli apart. The species of this family are strictly aquatic and found in lakes, ponds, ditches and rivers.

Key to the species of the family ERPOBDELLIDAE

- | | |
|--|-------------------------------------|
| 1. No dorsal canal from stomach to exterior. ... | 2 |
| Dorsal canal from stomach to exterior present. ... | <i>Foraminobdella heptamerata</i> |
| 2. No accessory post-cephalic eyes. ... | 3 |
| Accessory post-cephalic eyes present. ... | 4 |
| 3. Eyes four pairs ; no anterior vestigial jaws or teeth. ... | <i>Erpobdella octoculata</i> |
| Eyes three pairs ; one or two stiliform teeth. ... | <i>Barbronia weberi</i> |
| 4. First pair of eyes on somite three ; gonopore separated by two to three annuli. ... | <i>Herpobdelloidea lateroculata</i> |
| First pair of eyes on somite four ; gonopore separated by five annuli. ... | <i>Nematobdella indica</i> |

Genus : **Barbronia** Johansson

1918. *Barbronia* Johansson, *Zoologie*, 2 (13) : 373-396, pl. xii, 6 text-figs.

Generally of small sized leeches, colour reddish as little pigment present. Eyes normally three pairs, one large pair and two buccals, complete somite quinquannulate. Gonopores nearly separated by full somite.

Barbronia weberi (Blanchard)

1897. *Dina weberi* Blanchard, *Zool. Ergeb. Reise in Neiderlandisch Ost-India*, 4 : 332-355. (Type-Locality : Java ; Type-Deposited : Not known).
1918. *Barbronia rouxi* Johansson, Sarasin V. Roux, *Nova Caledonia, Zoologie*, 2 (13) : 373-396.
1983. *Barbronia weberi*, Chandra, *Rec. zool. Surv. India*, 80 : 280.

Diagnostic characters : Small sized leeches, 25-35mm long, living colour unknown, probably reddish as little pigment is present. Eyes three pairs, one large pair on dorsum of 11, two smaller pairs on sides of anterior annulus of IV. Gonopores separated by four and a half or nearly five annuli. Accessory copulatory pores and areas at X/XI and XIII/XIV are very characteristic. (Fig. 34).

Distribution : India : Srinagar, Kathua, Udhampur, Poonch, Rajouri (Jammu and Kashmir) ; Sirmour, Solan, Bilaspur, Shimla (Himachal Pradesh) ; Hoshangabad (Madhya Pradesh) ; Naini Tal (Uttar Pradesh).

Outside India : Pakistan, Nepal, Java, Sumatra, Borneo and Philippines.

Field observation : The specimens of this species are found attached to stones and other submerged articles in lakes, tanks, pools and small streams. Generally of reddish colour with very little pigmentation. They are found in association with other glossophonids.

Genus : Erpobdella Blainville

1818. *Erpobdella* Blainville, In Lamarck, *Histoire Naturelle des Animaux sans Vertebres*, 5.

Complete somite quinquannulate. Eyes usually three or four pairs, one or two pairs in a labial group on the dorsum of the lip, and two pairs on the sides of the buccal ring. Vase differentia in all known species form long preatrial loops reaching to ganglion xi.

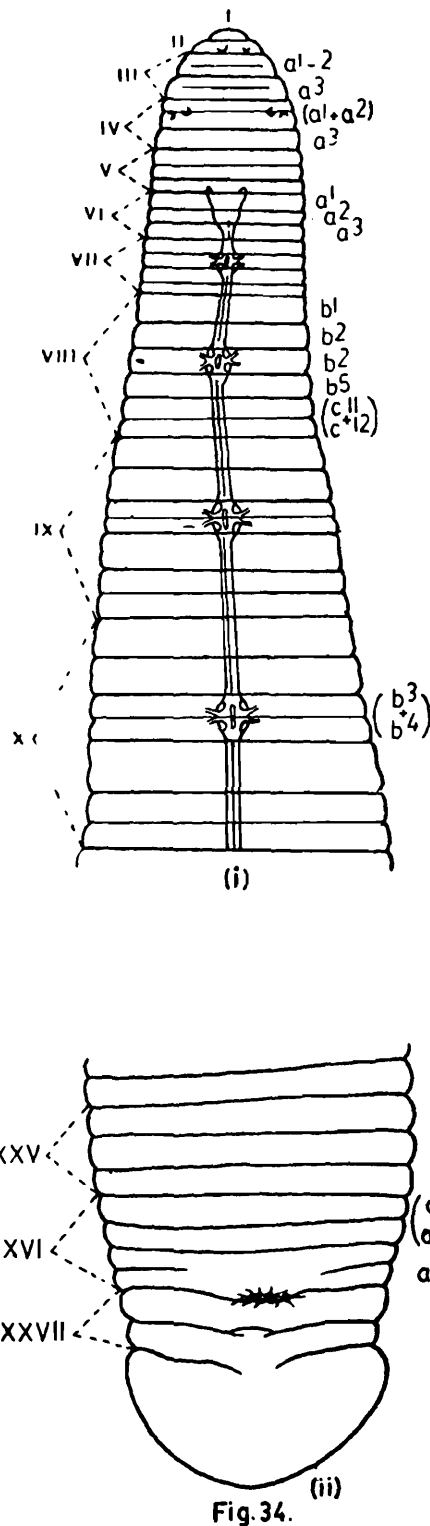

Fig. 34. *Barbronia weberi* (Blanchard). (i) Showing dorsal aspect of anterior end, annulation (notation at right) eyes, position of nerve ganglia- (ii) showing posterior or caudal end, anus and sucker.

Erpobdella octoculata (Linnaeus)

1758. *Hirudo octoculata* Linnaeus, *Systema Naturae*, 10th. ed. (Type-
Locality and Type-Deposited : Not known).
1927. *Erpobdella octoculata*, Moore, *Fauna Brit. India*, Hirudinea, 130-135.
1983. *Erpobdella octoculata*, Chandra, *Rec. zool. Surv. India*, 80 : 280.

Diagnostic characters : Size of the Indian specimens are smaller in comparison to European specimens. Form more robust than other species of the family, nearly uniform, but attenuated anterior to clitellum. Head relatively small. Eyes normally four pairs, the first pair on II, the second at the furrow II/III, the third and fourth pairs at the sides of the buccal ring on IV. Clitellum well marked in breeding individuals. Gonopores separated by two and one-half annuli. (Fig. 35).

Distribution : India : Srinagar, Bhadarwa (Jammu and Kashmir). Outside India : Lahore (Pakistan), Europe and Palestine.

Field observation : The species is generally found in lakes and small streams attached to submerged articles. Colour translucent amber or brownish. Sometimes found in association with *Hemiclepsis marginata asiatica* Moore.

Genus : Foraminobdella Kaburaki

1921. *Foraminobdella Kaburaki*, *Rec. Indian Mus.*, 18 : 689-719.

Size medium and form robust. Eyes a single dorsal pair on III. Complete somite consists of seven annuli. A dorsal opening into the stomach at XIV/XV. Only one Indian species is known.

Foraminobdella heptamerata Kaburaki

1921. *Foraminobdella heptamerata* Kaburaki, *Rec. Indian Mus.*, 18 : 689-719. (Type-Localities : Nedurattan, Tamil Nadu ; Type-Deposited : Z.S.I.).
1983. *Foraminobdella heptamerata*, Chandra, *Rec. zool. Surv. India*, 80 : 282.

Diagnostic characters : Size medium, large and more robust. Colour in preserved specimen is grey or slaty above,

paler grey below. Eyes one pair on III. Complete somite formed of seven annuli. Gonopores separated by a full somite. A large orifice at XIV/XV, opening into the stomach.

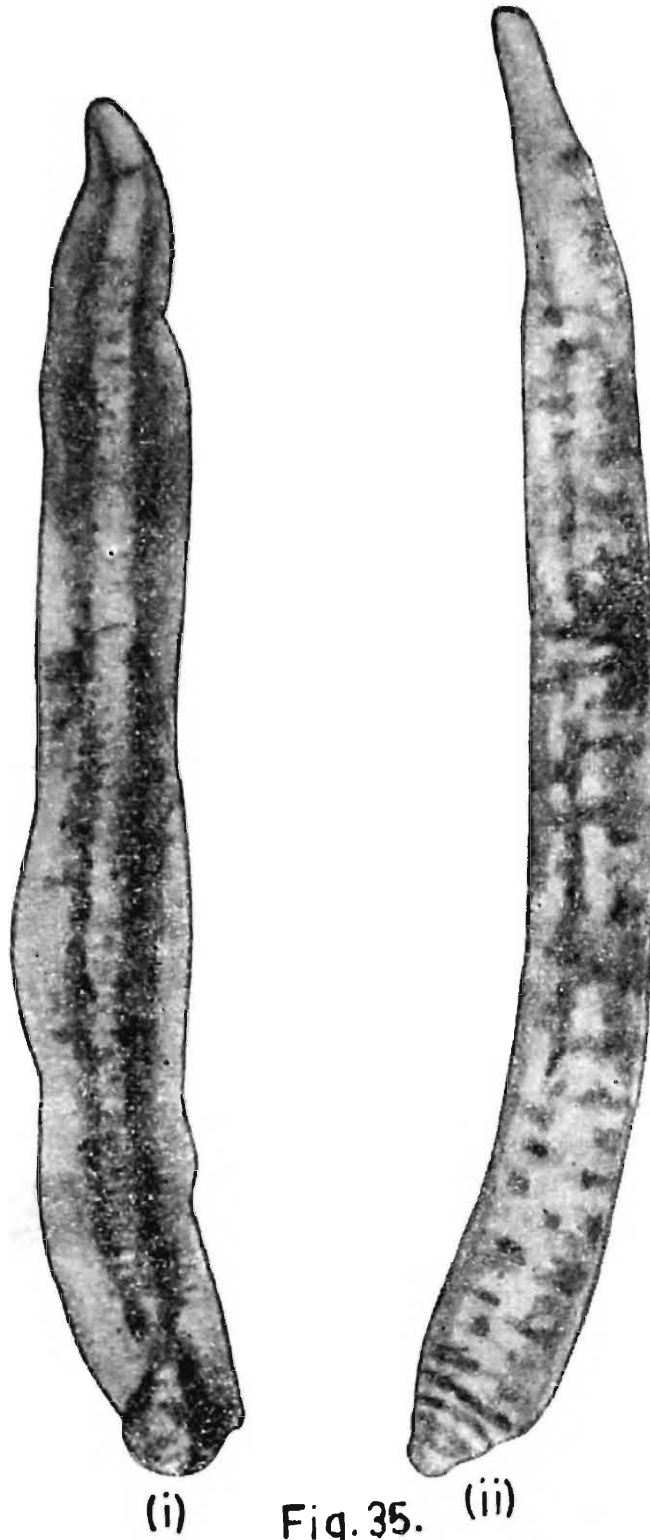

Fig. 35. *Erpobdella octoculata* (Linnaeus). (i), (ii) Dorsal view. (After Moore, 1927).

Clitellum, thick, sharply defined extending over full three somites. The surface of the body is much wrinkled (Fig. 36).

Distribution : India : Nedurattan, Nilgiris (Tamil Nadu).



Fig. 36.

Fig. 36. *Foraminobdella heptamerata* Kaburaki. Dorsal view (After Moore, 1927).

Field observation : The species found in streams. The structure suggests the species being amphibious and burrowing in nature. Not much is known of its habitat.

Genus : *Herpobdelloidea* Kaburaki

1921. *Herpobdelloidea* Kaburaki, *Rec. Indian Mus.*, 22 : 668-719.

Small and slender. Eyes a single dorsal pair on IV and

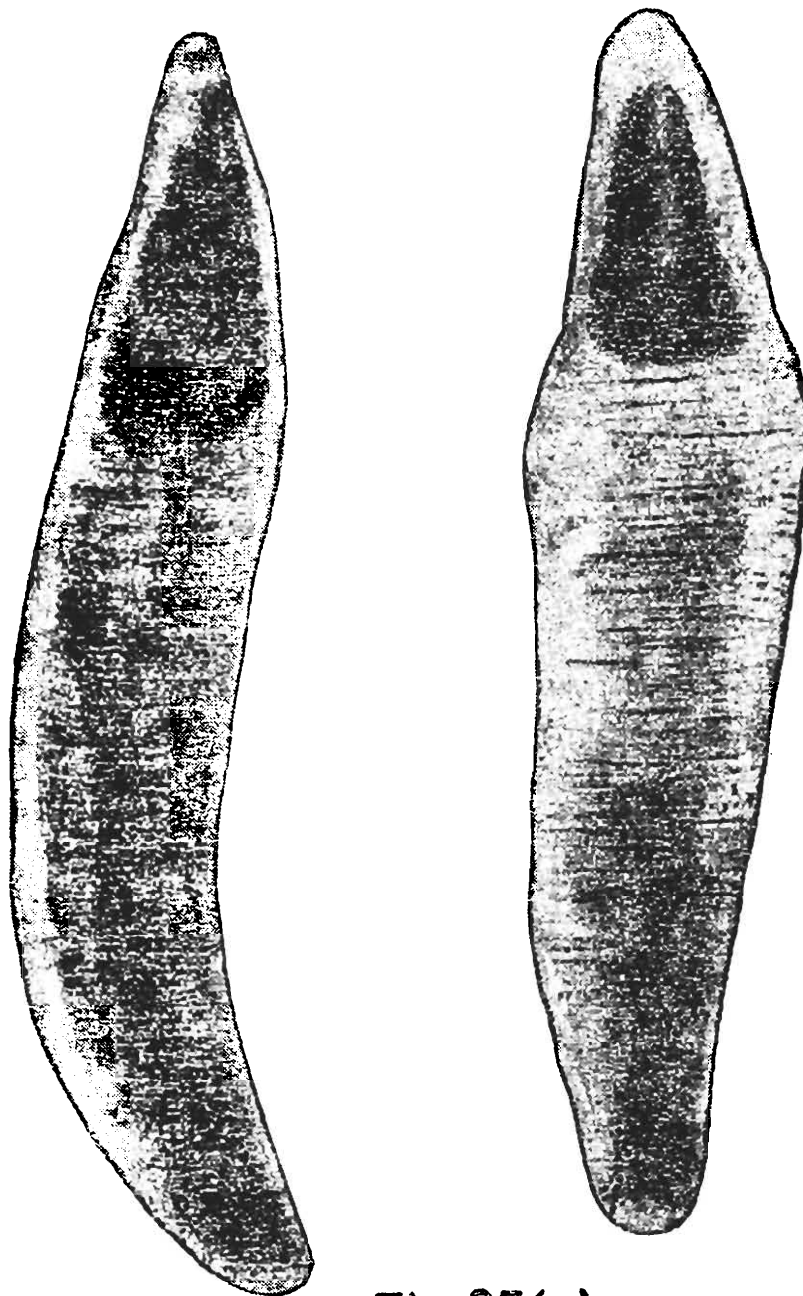

Fig.37.(a).

Fig. 37. (a) *Herpobdelloidea lateroculata* Kaburaki. Dorsal view. (After Moore, 1927),

several smaller submarginal pairs on the sensory annuli of somites IV to VIII, rarely IX inclusive or some of them. Complete somites showing a tendency towards enlargement, a division of the fifth annulus.

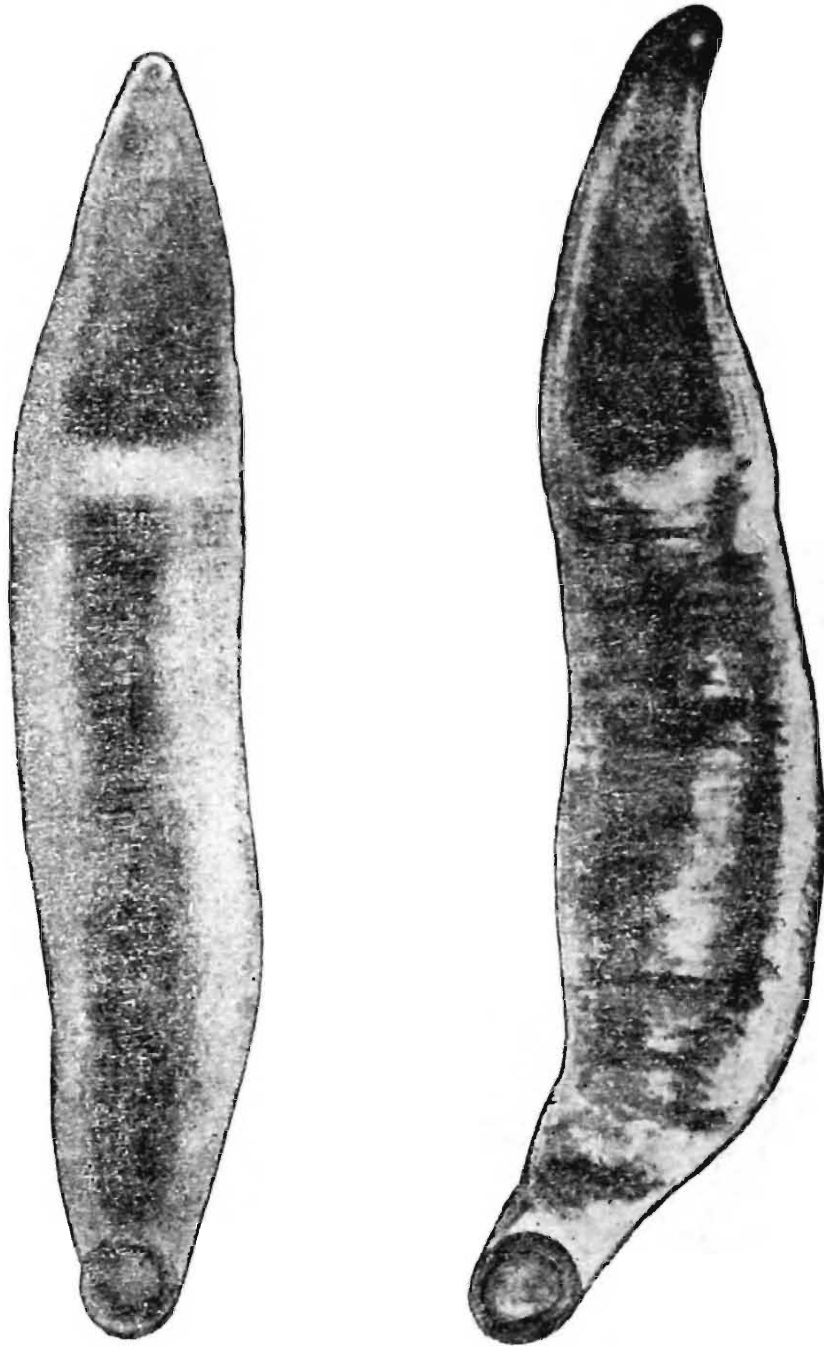

Fig. 37.(b).

Fig. 37. (b) Ventral view. (After Moore, 1927).

Herpobdelloidea lateroculata Kaburaki

1921. *Herpobdelloidea lateroculata* Kaburaki, *Rec. Indian Mus.*, 22 : 689-719, 7 text-figs. (Type-Locality : Saugar, Madhya Pradesh ; Type-Deposited : Z.S.I.).
1983. *Herpobdelloidea lateroculata*, Chandra, *Rec. zool. Surv. India*, 80 : 281.

Diagnostic characters : Size smaller and slender. Eyes five or rarely six pairs, the first larger and dorsal on IV, the others ventro-lateral on IV to VIII, rarely on IX. Complete somite quinquannulate. Gonopores separated by two and a half to three annuli. Head small, lipless, prolonged and narrow. Clitellum well developed. (Fig. 37a and 37b).

Distribution : India : Jodhpur, Nagaur (Rajasthan) ; Bushampur, Saugar (Madhya Pradesh) ; Satara (Maharashtra) ; Loktak Lake (Manipur) ; Kathua, Jammu, Poonch (Jammu) and Kashmir).

Field observation : The species is found in tanks, pools and lakes. They can be collected free-living or attached to submerged articles. In life the colour is translucent pale with darker alimentary canal. Preserved specimens are yellowish.

Genus : Nematobdella Kaburaki

1921. *Nematobdella* Kaburaki, *Rec. Indian Mus.*, 22 : 689-719.

Size small, form very slender, much attenuated anteriorly. Eyes six pairs, the first pair dorsal on III and the remaining five pairs smaller, submarginal from V to IX inclusive. Complete somites of unequal six annuli.

Nematobdella indica Kaburaki

1921. *Nematobdella indica* Kaburaki, *Rec. Indian Mus.*, 22 : 689-719. (Type-Locality : Dharampur, Himachal Pradesh ; Type-Deposited : Z.S.I.).
1983. *Nematobdella indica*, Chandra, *Rec. zool. Surv. India*, 80 : 281.

Diagnostic characters : Form unusually slender, uniform most of its length, but slightly wider at middle and very slender pointed cephalic end. Head very small. Eyes six pairs, the first pair largest, dorsal and directed

forwards on III. Supplementary eyes much smaller, variable on V to IX, directed laterad and increasingly cauded.

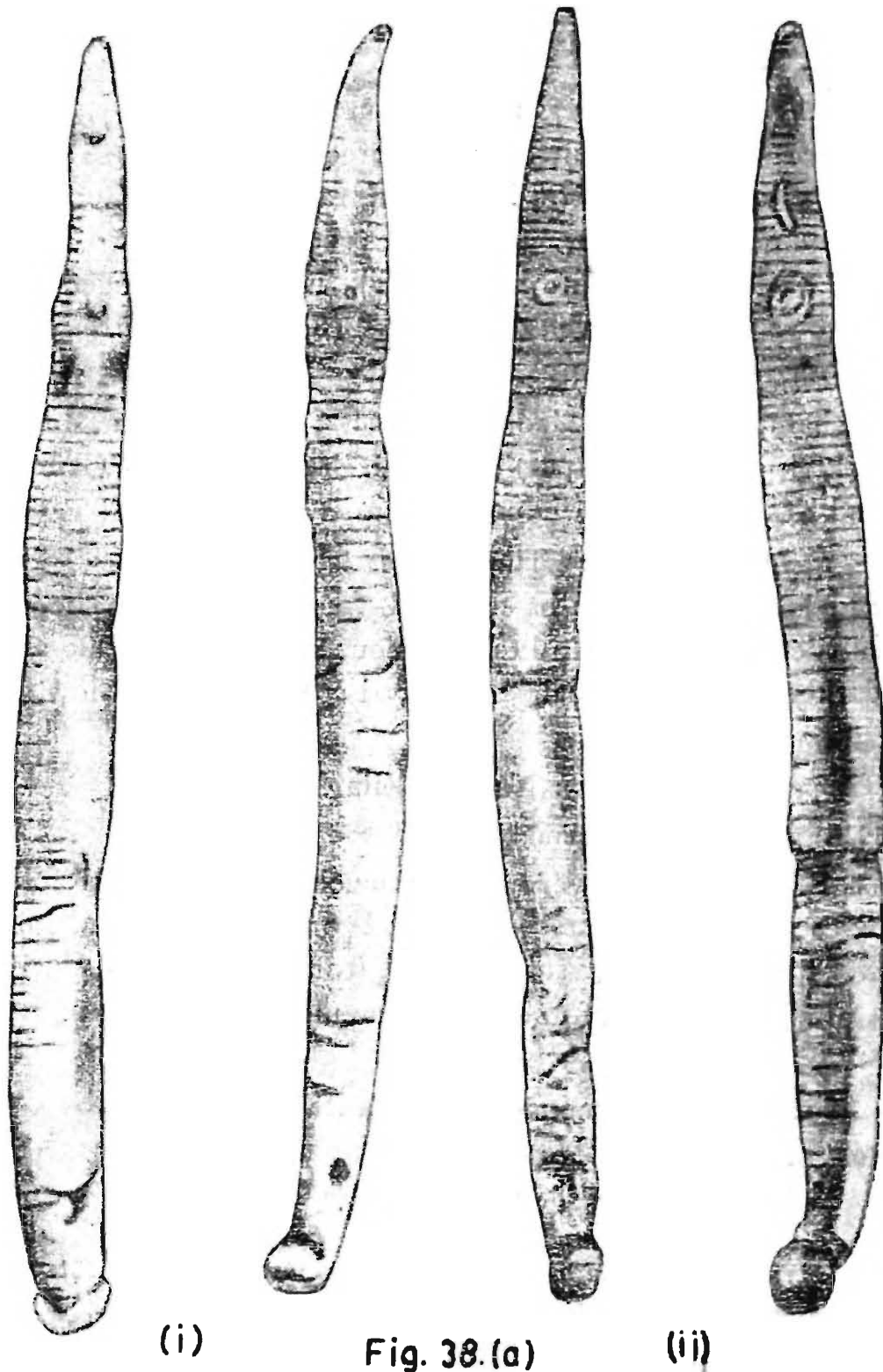

Fig. 38. (a) *Nematobdella indica* Kaburaki. (i) Dorsal view. (ii) Ventral view. (After Moore, 1927).

Clitellum well developed, gonopores separated by five annuli.
(Fig. 38a, 38b).

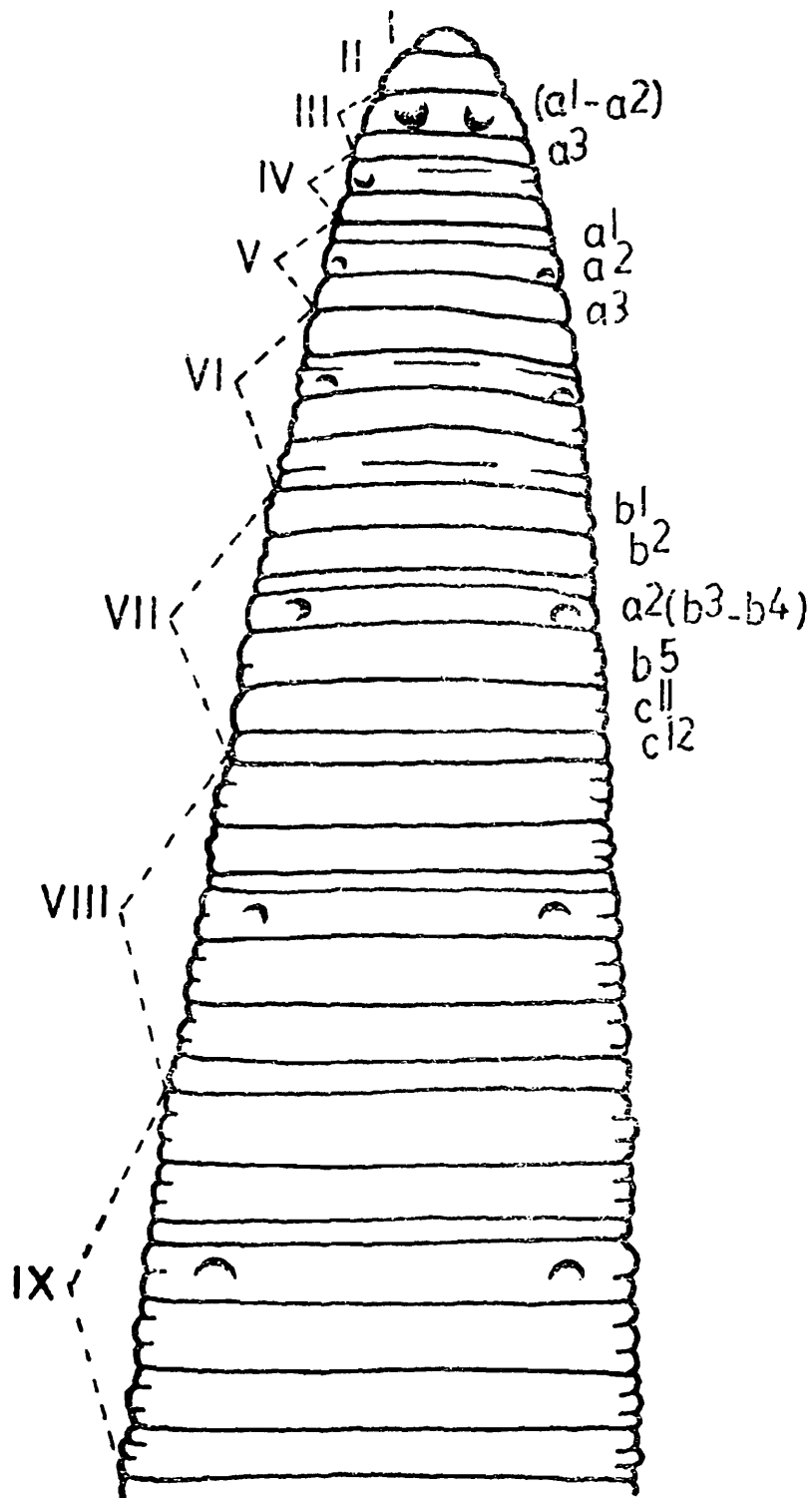

Fig. 38.(b)

Fig. 38. (b) Dorsal aspect of somites I-X showing annulation and pigment-cups of eyes.

Distribution : India : Nagaur, Jodhpur (Rajasthan); Dharampur (Himachal Pradesh); Kalka (Haryana); Kathua, Jammu, Udhampur (Jammu and Kashmir).

Field observation : The specimens can be collected from tanks, pools and lakes; they are free-living and attached to submerged articles. In life the colour is of reddish tinge with no pigmentation. The preserved specimens are of opaque grey or white.

Diagnostic Characters of : Family HIRUDIDAE

The species of this family are of medium to very large size, some of them attain a length of 37.5 cm or even 45 cm and a width of 2.5 cm when fully extended. These are true jawed leeches with five pairs of eyes forming a regular arch. Third and fourth pairs of eyes are separated by an annulus. Complete somites quinquannulate. Dorsal sensillae in eight and ventral in six series.

They live mostly in water and most of these are amphibious more or less. Most members of this family are swamp animals rather than inhabitants of larger and deeper waters.

Key to the species of family Hirudidae

- | | | |
|--|----------------------------------|---|
| 1. Jaws small and weak. | ... | 2 |
| Jaws well developed. | ... | 4 |
| 2. Head not attenuated; stomach caecate;
somite imperfectly 5 annulate. | ... <i>Myxobdella annandalei</i> | |
| Head attenuated; stomach caecate;
somite perfectly 5 annulate. | ... | 3 |
| 3. Teeth coarse and all distichous. | ... <i>Haemopsis indicus</i> | |
| Teeth imperfect in two series | ... <i>Whitmania laevis</i> | |
| 4. Teeth absent or vestigial. | ... | 5 |
| Teeth well developed. | ... | 6 |
| 5. Caudal sucker equal or exceeding body
width. | ... <i>Dinobdella ferox</i> | |
| Caudal sucker much less than body
width. | ... <i>Dinobdella notata</i> | |

6. Salivary papillae on jaws absent or rarely a few very small ones ; median ventral fissure on lip absent. ...	7
Salivary papillae on jaws numerous ; large median ventral fissure on lip present. ...	8
7. Colour uniform ; no metameric spots. ...	<i>Hirudo asiatica</i>
Colour pattern longitudinally striped ; metameric spots present. ...	<i>Hirudo birmanica</i>
8. Vaginal stalk absent. ...	9
Vaginal stalk well-developed. ...	10
9. Gonopores separated by seven annuli. ...	<i>Poecilobdella javanica</i>
Gonopores separated by five annuli. ...	<i>Poecilobdella manillensis</i>
10. Vaginal stalk about equal in length to caecum. ...	<i>Poecilobdella granulosa</i>
Vaginal stalk about twice the length of caecum. ...	<i>Poecilobdella viridis</i>

Genus : *Dinobdella* Moore

1927. *Dinobdella* Moore, *Fauna Brit. India, Hirudinea*, 175.

Size and form variable. Colour nearly solid without definite pattern. Complete somite of quadrannulate or quinquannulate. Eyes small, normal in arrangement but often obscure. Gonopores at XI and XII. Jaws small, smooth and edentulous.

Dinobdella ferox (Blanchard)

1896. *Whitmania ferox* Blanchard, *Mem. Soc. Zool. Fr.*, 9 : 316-330.
(Type-Locality : Not known ; Type-Deposited : British Museum).

1927. *Dinobdella ferox*, Blanchard, *Fauna Brit. India, Hirudinea*, 175-185.

1983. *Dinobdella ferox*, Chandra, *Rec. zool. Surv. India*, 80 : 283.

Diagnostic characters : Size very large, upto 20 cm to 25 cm or more in life, elongated with greatest width far back, and anterior end slender. Colour in life dark green, entirely without markings. Head small, caudal sucker very large. Eyes five pairs, small and deeply placed hence usually obscure. Complete somites from IX to XXIV. Jaws small, smooth

and completely lacking teeth and papillae (Plate IA and Fig. 39).

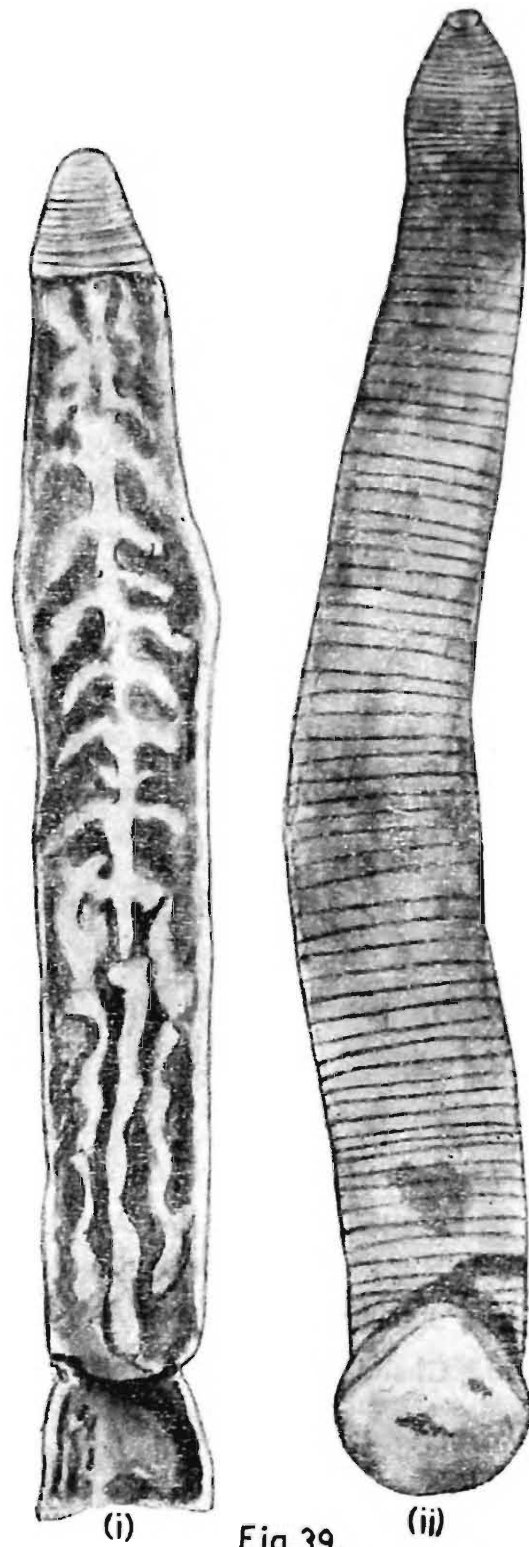

Fig. 39.

Fig. 39. *Dinobdella ferox* (Blanchard). Ventral view of parasitic individual. Dorsal view of dissected empty digestive tract of a free-living individual. (After Moore, 1927).

Distribution : India : Bilaspur (Himachal Pradesh); Muktesar, Nainital (Uttar Pradesh); Darjeeling (West Bengal); Manipur and Sikkim.

Outside India : Sri Lanka and Siam.

Field observation : The species is parasitic of domestic and wild mammals and also free-living in water. It can be found in ponds and paddy fields. It is also known as cattle-leech.

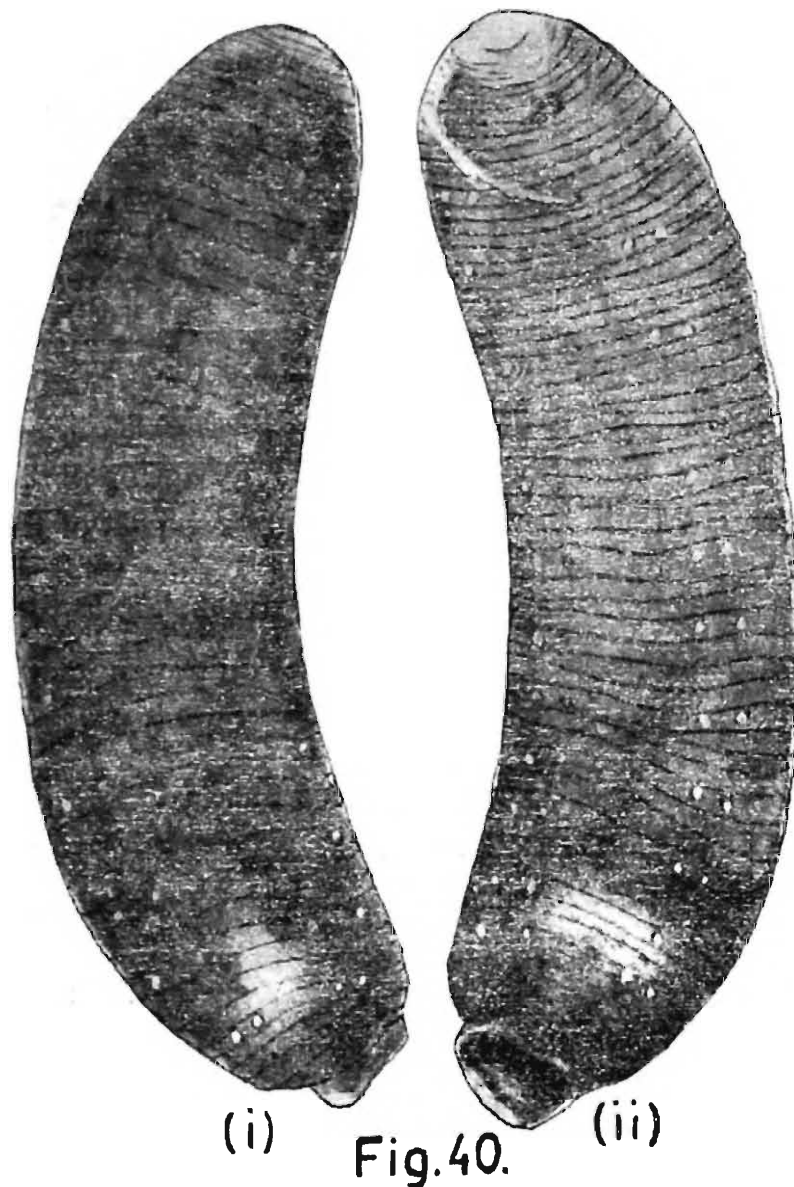

Fig. 40. *Dinobdella notata* Moore. (i) Dorsal view, (ii) ventral view. (After Moore, 1927).

Dinobdella notata Moore

1927. *Dinobdella notata* Moore, *Fauna Brit. India, Hirudinea*, 185-189.

1983. *Dinobdella notata*, Chandra, *Rec. zool. Surv. India*, 80 : 283.

Diagnostic characters : Size medium, in life probably 5 cm to 8 cm long when extended. The form is elongate, oblong-elliptical, with the ends nearly equally rounded, strongly flattened. Living colour probably dark olive-green clouded with dusky, but without definite colour markings ; paler and less green ventrally. Head and caudal sucker of about normal dimensions. Gonopores at XI and XII. Eyes small but clearly visible and typical in arrangement. Complete somites IX to XXIII. Jaws small and edentulous. (Fig. 40).

Distribution : India : Kodaikanal, Otacamund and Keti (Tamil Nadu).

Field observation : The species is free living and amphibious at swampy places.

Genus : Haemopsis Savigny

1920(1922). *Haemopsis* Savigny, *Systeme des Annelides*, Paris.

In living condition the body is exceptionally soft and flabby. The body is thick for the greater part of its length, gently tapering at the anterior, and posterior extremities. Caudal sucker is small and weak. Colour dark without any definite markings. Complete somite quinquannulate. Jaws small and weak (two rows of teeth).

Haemopsis indicus Bhatia

1940. *Haemopsis indicus* Bhatia, *Proc. nat. Acad. Sci. India*, 10(4) : 133-144.

(Type-Locality : Pahalgam Kashmir ; Type-Deposited : Not known).

1983. *Haemopsis indicus*, Chandra, *Rec. zool. Surv. India*, 80 : 280.

Diagnostic characters : Body exceptionally soft and flabby. It is thick for greater part of its body, gently tapering at both the extremities. The ventral surface is more or less flat and the dorsal is broadly arched. The posterior sucker is small and weak. Colour dark without any definite markings. The five pairs of eyes are arranged as usual ; the fourth is

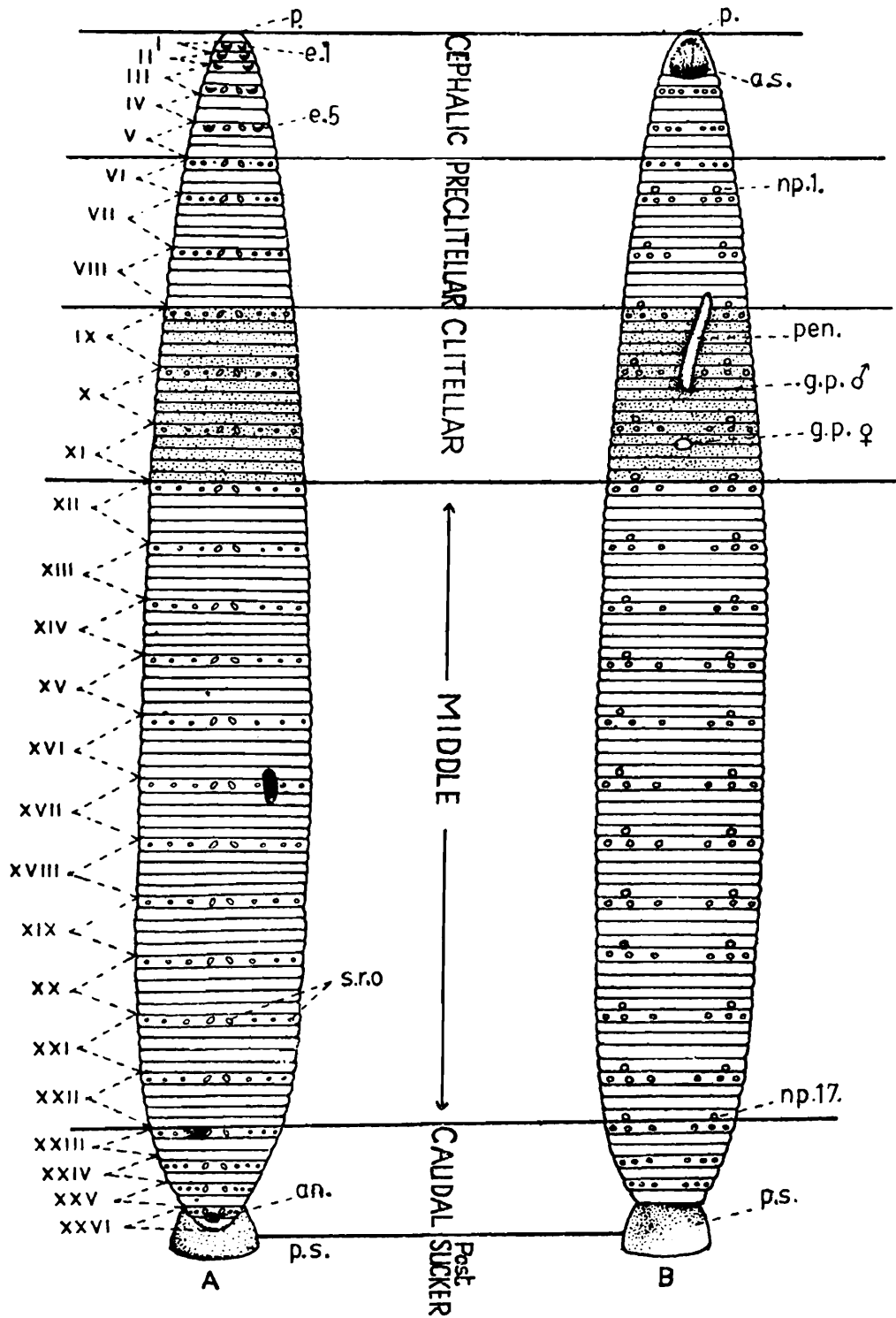

Fig. 41.

Fig. 41. Diagram showing external features of *Haemopsis indicus* Bhatia. A. Dorsal ; B. Ventral aspects. *an.*, anus ; *as.*, anterior sucker ; *e.1*, first and *e.5*, fifth pair of eyes ; *g.p.*, male generative aperture ; *g.p.*, female generative aperture ; *n.p.1*, first and *n.p.17*, seventeenth pair of nephridiopores ; *p.*, prostomium ; *pen.*, penis ; *p.s.*, posterior sucker ; *s.r.o.*, segmental receptor organ ; I-XXVI, the body segment. (After Bhatia, 1939).

separated from third by single annuli and the fifth from fourth by two annuli. The gonopores are separated by five annuli. (Fig. 41).

Distribution : India : Pahalgam, Srinagar (Jammu and Kashmir).

Field observation : The leeches are commonly known as burrowing leeches and inhabit swamps and shallow waters. They are found attached to submerged articles, burrowing in soft muds. They are also amphibious in nature.

Genus : *Hirudo* Linnaeus

1758. *Hirudo* Linnaeus, *Systema Nature*, 10th ed.

Size medium to large. Colour pattern usually longitudinally striped, but occasionally spotted or solid. Eyes five pairs well developed. Somites IX to XXIII or upto XXIV complete and quinquannulate. Gonopores constantly on XI and XII. Jaws prominent but variable in length. Teeth typically monostichodont, acute, conical and from 40-100 in each jaws.

Hirudo asiatica Blanchard

1896. *Hirudo asiatica* Blanchard, *Mem. Zool. Soc. Fr.*, 9 : 316-330. (Type-Locality : Afghanistan ; Type-Deposited : British Museum).

1983. *Hirudo asiatica*, Chandra, *Rec. zool. Surv. India*, 80 : 283.

Diagnostic characters : Size small 5 cm to 8 cm in length, slender with larger sucker. Colour uniform dark olive or brown without markings. Sensillae obscure. Complete somites quinquannulate from IX to XXV. Jaws prominent but short, teeth monostichodont, about 50, no salivary papillae. Five pairs of eyes arranged on annuli 2, 3, 4, 6 and 9. (Fig. 42).

Distribution : India : Kanpur (Uttar Pradesh). Outside India : Afghanistan.

Field observation : The species is found in freshwater and attacks frogs.

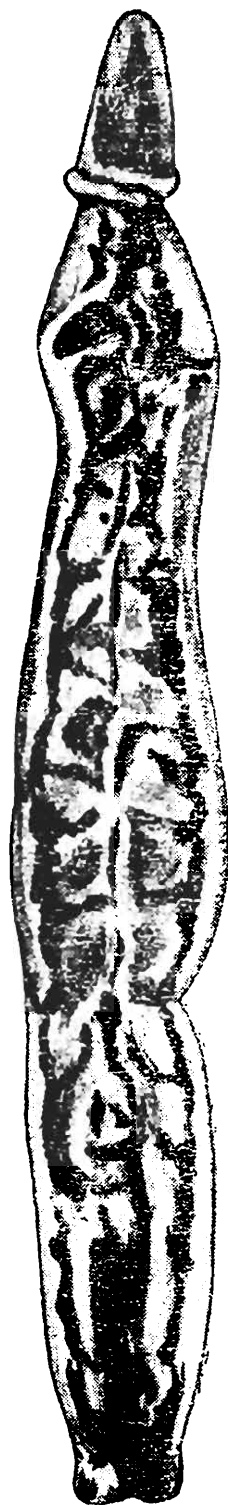

Fig.42.

Fig. 42. *Hirudo asiatica* Blanchard. Dorsal view of partly dissected digestive tract and reproductive organs. (After Moore, 1927).

Hirudo birmanica (Blanchard)

1894. *Haemopsis birmanica* Blanchard, *Annali. Mus. Civ. Stor. nat Giacomo Doria*, 2 (14): 113-118. (Type-Locality: Kareni Mountains, Burma; Type-Deposited: Genova Museum).
1927. *Hirudo birmanica*, Moore, *Fauna Brit. India, Hirudinea*, 192-199.
1983. *Hirudo birmanica*, Chandra, *Rec. zool. Surv. India*, 80 : 283.

**Fig. 43.**

Fig. 43. *Hirudo birmanica* (Blanchard). Dorsal view to show colour pattern. (After Moore, 1927).

Diagnostic characters : Length in life from 5 cm to 7 cm long, slender and small-headed. Colour olive or olive-brown with seven dusky or brown dorsal stripes. Cephalic sucker small and caudal sucker of medium size. Eyes arranged as usual but small. Jaws short and high bearing 43-59 conical teeth. The first three pairs of eyes on contiguous annuli, the fourth separated by one annuli and the fifth by two. Complete somite from IX to XXI and quinquannulate. (Fig. 43).

Distribution : India : Nagaur, Jodhpur (Rajasthan) ; Allahabad (Uttar Pradesh) ; Sonali, Solmari (Bihar) ; Nilgiri Hills, Kilakaria (Tamil Nadu) ; Satara (Maharashtra) ; Mysore, Bangalore (Karnataka) ; West Bengal ; Punjab ; Udhampur, Rajouri (Jammu and Kashmir). Outside India : Pakistan, Sri Lanka and Burma.

Field observation : It is found in rivers, streams, swamps, tanks and even in wells. It attacks human beings and animals. It is free-living and sanguivorous.

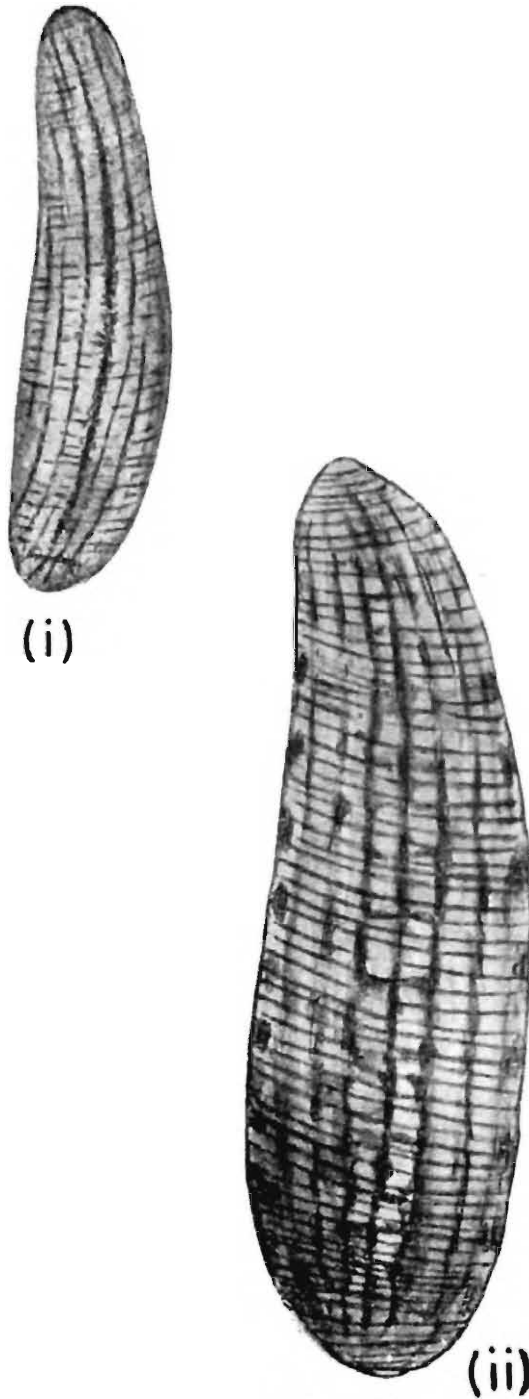
Genus : *Myxobdella* Oka

1917. *Myxobdella* Oka, *Mem. Asiat. Soc. Beng.*, 18 : 689-719.

The body is soft and flabby, thick for the greater part of its length, gently tapering at the posterior and anterior extremities, but caudal sucker much larger. Complete somite imperfectly quinquannulate. Jaws very small, distichodont with very few imperfect teeth.

Myxobdella annandalei Oka

1917. *Myxobdella annandalei* Oka, *Mem. Asiat. Soc. Beng.*, 18 : 689-719. (Type-Locality : Hong Kong ; Type-Deposited : Z.S.I.).

1983. *Myxobdella annandalei*, Chandra, *Rec. zool. Surv. India*, 80 : 282.

Diagnostic characters : Length in life about 5 cm to 10 cm. Form robust. Sucker large, nearly equal to maximum width. Colour pale grey, more or less closely maculated with black or dusky blotches. Complete somites from X—XXIII. Eyes five pairs on somite II to VI, small and

obscure. Gonopores separated by five annuli. Jaws very small and weak. Teeth very few, three or four in each row. (Fig. 44).

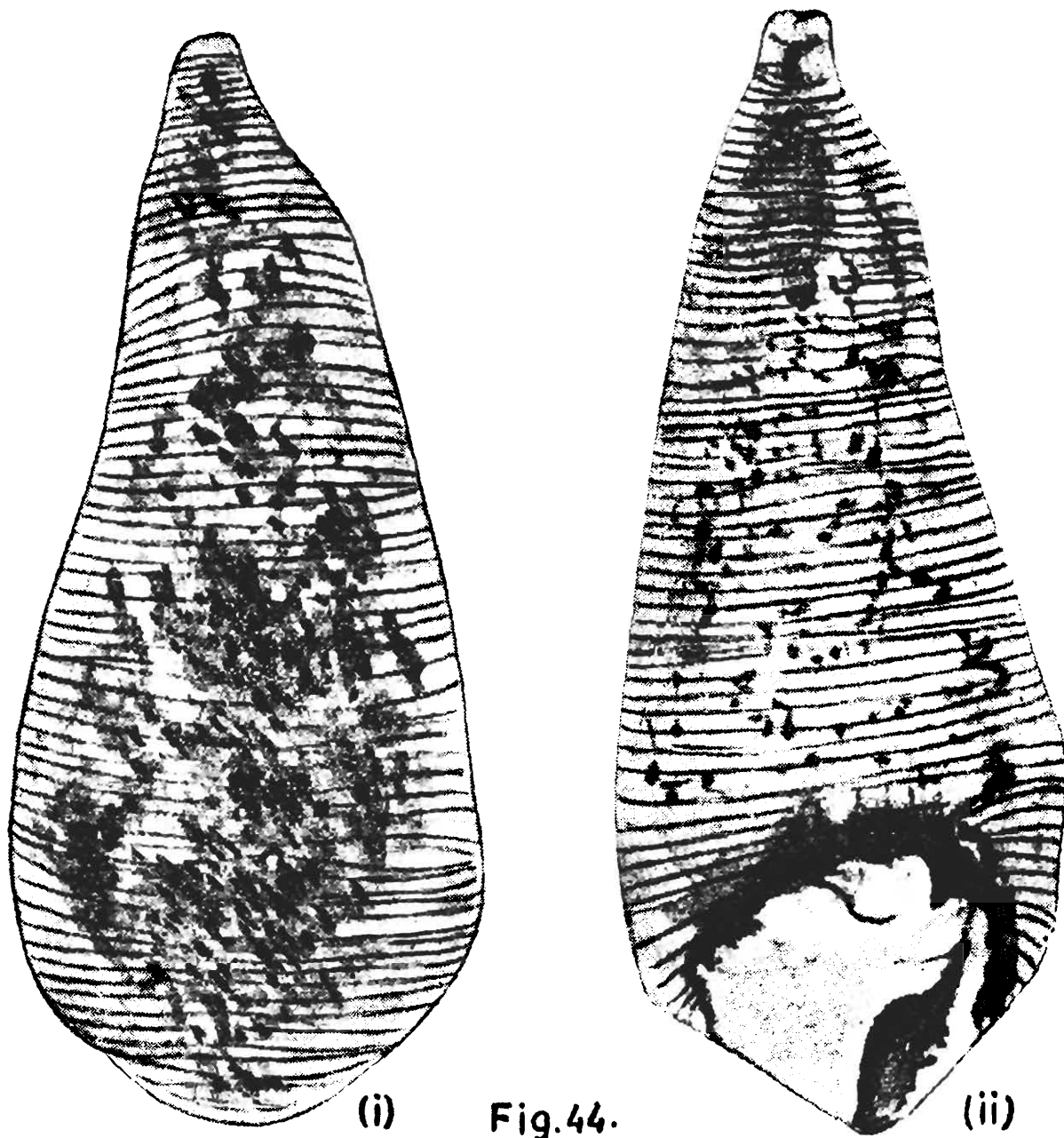

Fig. 44. *Myxobdella annandalei* Oka. (i) Dorsal view, (ii) Ventral view. (After Moore, 1927).

Distribution : India : Yercaud (Tamil Nadu).

Field observation : The specimens can be collected from hill streams attached to submerged articles,

Genus : *Poecilobdella* Blanchard

1893. *Poecilobdella* Blanchard, *Boll. Musei. zool. Anat. Camp. R. Univ. Torino*, 7 (145) : 1-32.

Size of the species of this genus is medium to very large. Form generally robust, widest near middle and tapered little to the ends. Colour variable, green, brown or reddish with a very precise pattern of black stripes and metameric spots, which becomes broken and dissipated with age. Eyes large, five pairs, arranged as usual. Gonopores separated by five or seven annuli. Jaws with more than one hundred acute, monostichodont teeth. Strictly sanguivorous as far as known.

***Poecilobdella granulosa* (Savigny)**

1820. *Sanguisuga granulosa* Savigny, *Systeme des Annelides*, Paris. (Type-Locality : Pondichery ; Type-Deposited : Not known).

1927. *Hirudinarin (Poecilobdella) granulosa*, Moore, *Fauna Brit. India, Hirudinea*, 226-238.

1970. *Poecilobdella granulosa*, Soos, *Opusc. zool. Bpest.*, 10 (2) : 313-324.

1983. *Poecilobdella granulosa*, Chandra, *Rec. zool. Surv. India*, 80 : 285.

Diagnostic characters : Size large and form robust than other species of the genus *Poecilobdella*. Colour of dorsum varied shades of olive-green, often divided by one or two pairs of yellowish longitudinal stripes, and marked by a black pattern consisting of a median constricted or broken line ; four pairs of narrow wavy lines bordering the yellow stripes. This pattern is variable and disappears with increasing size. Margins with yellow or orange stripe, venter usually reddish-orange with sub-marginal black stripe. Teeth usually about 100. (Plate Ib).

Distribution : India : Widely distributed in the states of Punjab, Himachal Pradesh, Uttar Pradesh, Gujarat, Madhya Pradesh, Tamil Nadu and also in Jammu and Kashmir, Assam and Rajasthan.

Outside India : Sri Lanka, Nepal and Burma.

Field observation : The species is found in rivers, marshes,

swamps, tanks and pools ; attack cattles and human beings. Highest altitudinal record is 3,000 mts. It is strictly sanguivorous. It is medicinal leech.

Poecilobdella javanica (Wahlberg)

1856. *Sanguisuga javanica* Wahlberg, *Ofversigt Kongl. Vet. Akad., Forth*, 233-234. (Type-Locality : Samarang, Java ; Type-Deposited : Not known).

1970. *Poecilobdella javanica*, Soos, *Opusc. zool. Bpest.*, 10 (2) : 313-324.

1983. *Poecilobdella javanica*, Chandra, *Rec. zool. Surv. India*, 80 : 284.

Diagnostic characters : The species attains a very large size, upto 175mm or more in life. Form relatively more slender and flattened than other species of the genus. Colour in life very striking, the dorsum being olive-green to grass-green or olive-brown with pattern of dark stripes and metameric spots, margins yellow or orange. Venter is bright brick-red or occassionally green. Gonopores separated by seven annuli. Caudal sucker very large almost equal to the maximum width of the body. Jaws large having more than 100 teeth. Eyes five pairs as usual on ring 2, 3, 4, 6, and 9. (Fig. 45 and Plate II).

Distribution : India : West Bengal ; Sikmai Turail (Assam) ; Manipur ; Udampur, Rajouri (Jammu and Kashmir). Outside India : Sri Lanka, Burma, Java, Sumatra, Malaysia and Philippines.

Field observation : The species inhabits paddy fields, tanks and pools. It attacks domestic animals and man. It can also be used as medicinal leech.

Poecilobdella manillensis (Lesson)

1842. *Hirudo manillensis* Lesson, *Revue Zoologique Societe Cruierieme*, 8. (Type-Locality : Luzon, Philippines Island ; Type-Deposited : Not known).

1970. *Poecilobdella manillensis*, Soos, *Opusc. zool. Bpest.*, 10 (2) : 313-324.

1983. *Poecilobdella manillensis*, Chandra, *Rec. zool. Surv. India*, 80 : 284.

Diagnostic characters : Form of the species is almost like *P. granulosa*, robust, broad headed, circular in buccal region,

broadly elliptical elsewhere with sides broadly rounded. Colour pattern and other external characters like *P. granulosa* but ground colour more inclined to brown dorsally and more

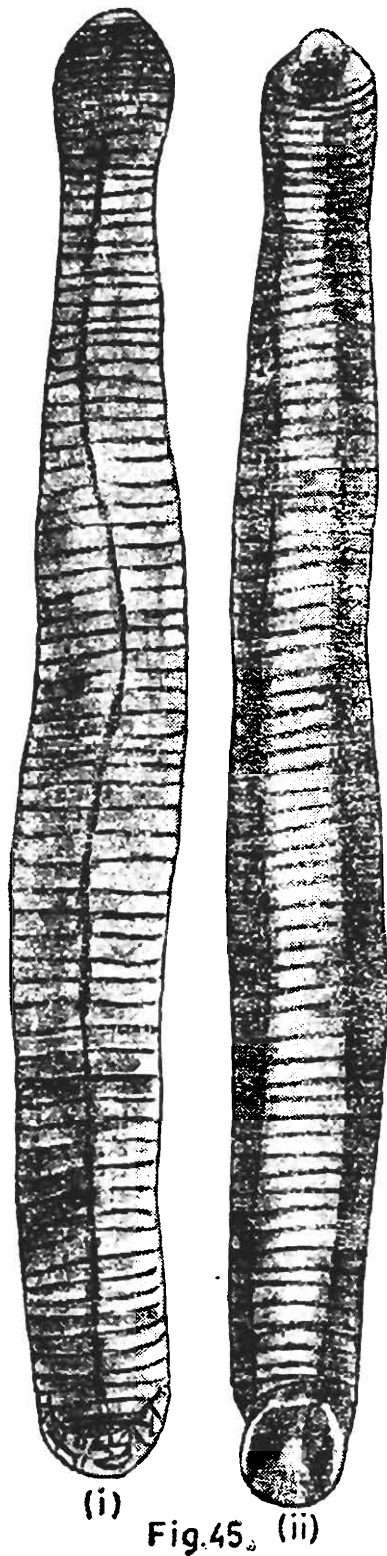

Fig. 45. *Poecilobdella javanica* (Wahlberg). (i) Dorsal view, (ii) Ventral view. (After Moore, 1927).

green ventrally. Teeth numerous, about 150. Caudal sucker smaller than in *P. javanica* with a well defined pedicel shaped, like a truncated wedge or flattened cone. It may attain a length of 103mm or so. (Plate III).

Distribution : India : Landaur (Uttar Pradesh) ; Darjeeling, Calcutta (West Bengal) ; Cachar (Assam) ; Karnataka ; Cochin (Kerala).

Outside India ; Pakistan, Sri Lanka, Burma, Borneo, Malaysia, Philippines and China.

Field observation : It is the common paddy-field, buffalo or medicinal leech of the lowlands of India. This species inhabits rice fields, swamps, ponds, tanks and in sluggish streams and springs. They also attack man and found attached to frogs, snakes and turtles.

Poecilobdella viridis Moore

1927. *Hirudinaria (Poecilobdella) viridis* Moore, *Fauna Brit. India*, Hirudinea, 239-243. (Type-Locality : Travancore, Kerala ; Type-Deposited : Z.S.I.).

1970. *Poecilobdella viridis*, Soos, *Opusc. zool. Bpest.*, 10 (2) : 313-324.

1983. *Poecilobdella viridis*, Chandra, *Rec. zool. Surv. India*, 30 : 283.

Diagnostic Characters : The general form of this species is similar to that of *P. granulosa*, colour is more greener and pattern disintegrated more completely earlier in life. The black pattern is chiefly limited to transverse rows of mid-metameric spots. Dorsum is bright olive-green and venter in greyish-green, sharply separated by bright marginal orange stripes. Head a little broader. The lip marked on the venter by a median furrow. Caudal sucker more or less smaller. (Fig. 46).

Distribution : India : Bilaspur (Himachal Pradesh) ; Varanasi (Uttar Pradesh) ; Etakare (Tamil Nadu) ; Travancore (Kerala) ; Kashmir (Jammu and Kashmir).

Field observation ; The specimens can be collected from paddy-fields, tanks and pools. Not much is known about its bionomics.

Genus : **Whitmania** Blanchard

1887. *Whitmania* Blanchard, *Dictionnaire encyclopedique Scs. med. Art.*,
Hirudinees, Paris, p. 153.

The genus is of large size. Body robust and slender,

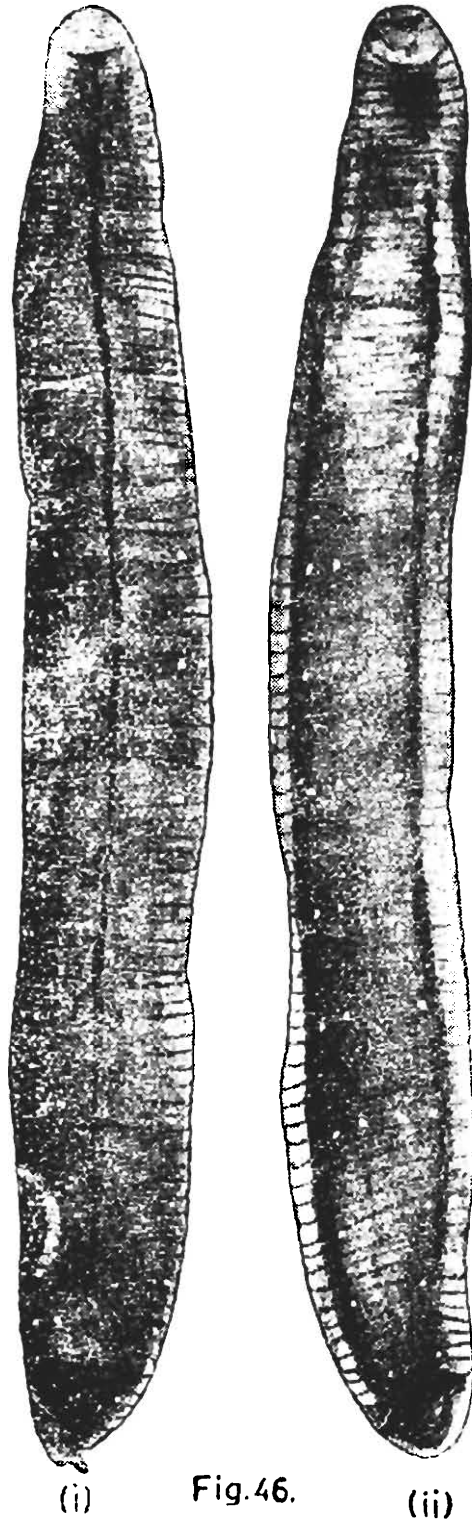

Fig. 46. *Poecilobdella viridis* Moore. (i) Dorsal view, (ii) Ventral view.
(After Moore, 1927).

attenuated cephalic region very characteristic. Sucker of medium size. Complete somites of five equal annuli, seventeen in number VII to XXIV, inclusive. Colour pattern longitudinally striped. Jaws small with imperfect tooth-plates or none.

Whitmania laevis (Baird)

1869. *Hirudo laevis* Baird, *Proc. zool. Soc. Lond.*, 310-318. (Type-
Locality : Japan ; Type-Deposited : British Museum).
1927. *Whitmania laevis*, Moore, *Fauna Brit. India*, Hirudinea, 168-175.
1983. *Whitmania laevis*, Chandra, *Rec. zool. Surv. India*, 80 : 282.

Diagnostic characters : Length when mature 10 cm to 15 cm. Thick-bodied for most of length, contracting sharply with the abruptly-tapered anterior end and small head. Sucker of medium size. Colour in life olive-brown on dorsum with five dark stripes, including pale yellow spots. Ventral side paler with a reddish or yellow tinge streaked and spotted with black. Jaws having two series of thin chitinoid plates in place of true teeth. This species has more slender anterior end with smaller sucker than *Dinobdella ferox*. (Fig. 47).

Distribution : India : Paglanadi (Manipur). Outside India : Burma, China, Formosa and Japan.

Field observation : The species can be collected from hill streams, ponds, ditches and submerged articles, It is very sluggish in nature.

Diagnostic Characters of : Family : HAEMADIPSIDAE

The family deals with the land or terrestrial leeches only. The specimens of this family are from small to medium size. Complete somites generally quinquannulate but varying from tri-to septannulate. Third and fourth pairs of eyes usually on contiguous annuli, only exceptionally separated by a more or less developed annulus. Buccal frill and anal appendages usually present. In this family only the genus *Haemadipsa* Tennent has so far been recorded from India,

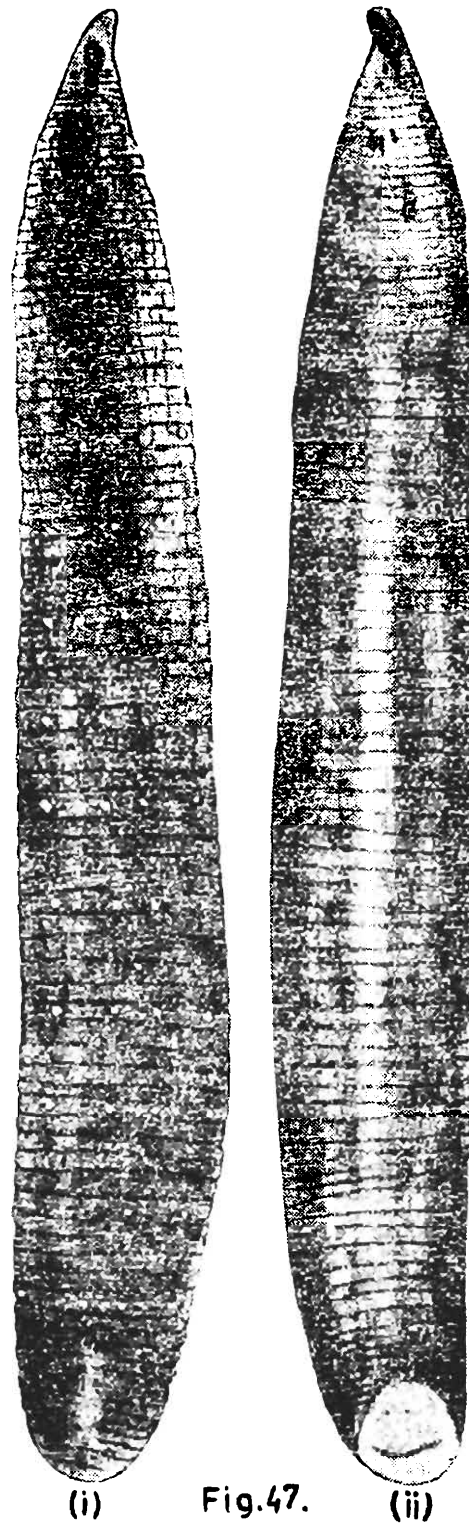

Fig 47. *Whitmania laevis* (Baird). (i) Dorsal view, (ii) Ventral view.
(After Moore, 1927).

Key to the Indian species of Family Haemadipsidae

- | | |
|--|---|
| 1. Somite VII 3-annulate and VIII 4-annulate. ... | 2 |
| Somite VII 4-annulate and VIII 5-annulate. ... | <i>Haemadipsa dussumieri</i> |
| 2. Furrow pits obscure, when present on IX to XII ; prehensile papilla on caudal sucker well developed. ... | 3 |
| Furrow pits evident, on VIII to XI ; prehensile papilla on caudal sucker little developed. ... | 6 |
| 3. Eyes 3 and 4 on contiguous annuli. ... | 4 |
| Eyes 3 and 4 separated by a complete or partial annulus. ... | 5 |
| 4. Colour pattern mottled with black above and below ; a black or dark stripe constant ; no paler median dorsal field ... | <i>Haemadipsa zeylanica cochini</i> |
| A median dorsal yellow or greenish yellow line ; colour reddish brown or orange mottled with black. ... | <i>Haemadipsa zeylanica zeylanica</i> |
| A median dorsal black or dark line in paler median field ; ground colour variable with dark blotched spots. ... | <i>Haemadipsa zeylanica agilis</i> |
| A median dorsal black or dark-line in a paler median field ; ground colour variable, dark spots or blotches absent or obscure. ... | <i>Haemadipsa zeylanica montivindicis</i> |
| 5. Clitellum prominent. ... | <i>Haemadipsa montana</i> |
| Clitellum not prominent. ... | <i>Haemadipsa moorei</i> |
| 6. Colour brown with usually three black dorsal stripes ; sucker rays usually 74-76. ... | <i>Haemadipsa sylvestris</i> |
| Colour velvety black alternating with cream or pale yellow stripes ; venter red ; sucker rays usually 86-94, ... | <i>Haemadipsa ornata</i> |

Genus : **Haemadipsa** Tennent

1859(1861). *Haemadipsa* Tennent, Ceylon. An account of the Island etc. *Leeches*, 1 : 301-307, text-figs.

The leeches are of small size ; form is slender, sub-cylindrical tapering to head from near caudal end, which is massive. Both size and form much altered when distended with blood. Colour varied, usually longitudinally striped or mottled. Lip more or less triangular. Eyes large, the first four pairs usually on contiguous annuli, but the third and fourth pair may be separated by a partial or complete annulus. Gonopores separated by five annuli usually. Jaws three, very high and prominent without papillae. Teeth acute, conical, slightly curved, in moderate number.

Haemadipsa dussumieri Blanchard

1917. *Haemadipsa dussumieri* Blanchard, *Bull. Soc. Path. expt.*, 10 : 640-675. (Type-Locality : South India ; Type-Deposited : Paris Museum).

1927. *Haemadipsa dussumieri*, Moore, *Fauna Brit. India*, Hirudinea, 289-290.

1983. *Haemadipsa dussumieri*, Chandra, *Rec. zool. Surv. India*, 80 : 287.

Diagnostic characters : Somites IX-XXIII complete (quinquannulate). Total number of annuli 100. Male and female gonopores separated by five rings. Somite VII-quadrannulate, VIII-quinquannulate and XXIV-quadrannulate, such constitution of somites are not found in any other species of *Haemadipsa*. The species needs further detailed studies.

Distribution : South India.

Field observation : Not much is known about its bionomics and habitat.

Haemadipsa montana Moore

1927. *Haemadipsa montana* Moore, *Fauna Brit. India*, Hirudinea, 269-276. (Type-Locality : Palni Hills, Tamil Nadu ; Type-Deposited : Z.S.I.).

1983. *Haemadipsa montana*, Chandra, *Rec. zool. Surv. India*, 80 : 287.

Diagnostic characters : Size small, cylindroid, tapering

from the broad sucker pedicel to the head, but sucker somewhat larger. Living colour unknown, but probably differing chiefly in being redder. Colouration variable partly blotched partly striped or more or less both. Marginal stripes pale-yellow or white and widen irregularly. There is no paler median field. When the linear pattern is clear then there are seven dorsal dark stripes and a narrow brown or black median stripe for the entire length from the first pair of eyes

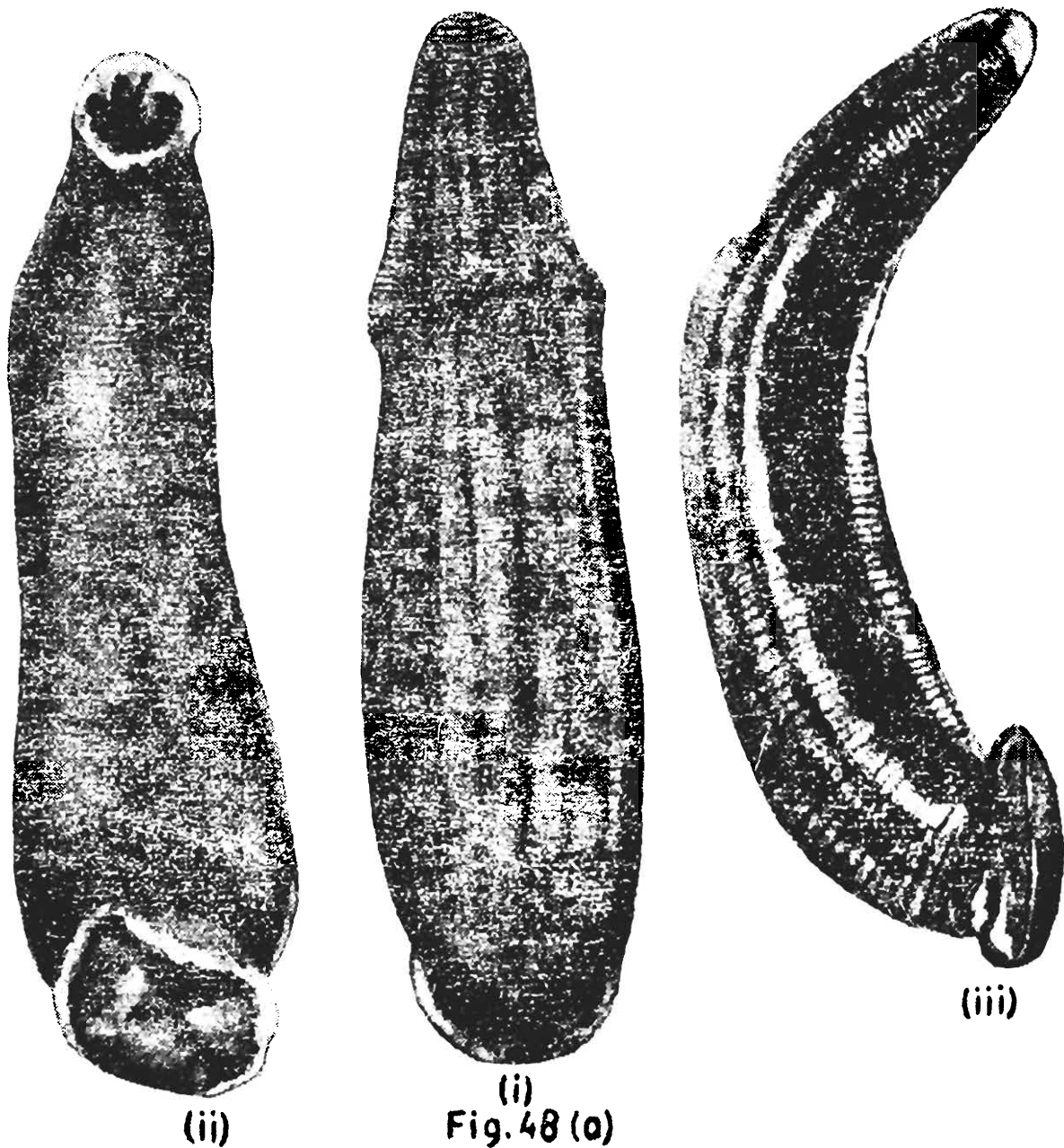

Fig. 48. (a) *Haemadipsa montana* Moore. (i) Dorsal view, (ii) Ventral view and (iii) Lateral view. (After Moore, 1927).

to anus. Dorsal is darker and venter is uniform yellow or buff with well defined sub-marginal stripes of white colour or nearly so. Ventral face of both suckers grey. (Fig. 48a, 48b).

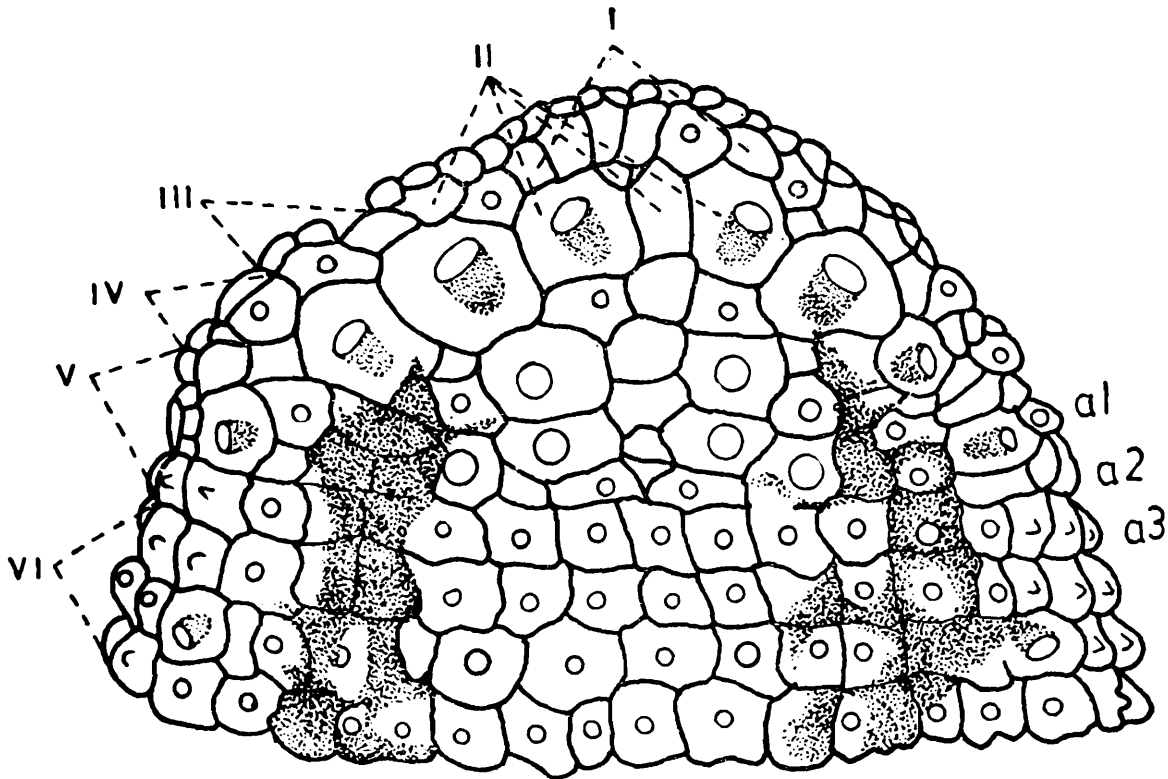

Fig. 48. (b)

Fig. 48. (b) Dorsal aspect showing somites I-VI, from dorsum showing stippled areas of the paired Chain-stripes, eyes and other sense organs. (After Moore, 1927).

Distribution : India : Darjeeling (West Bengal) ; Makai-bari, Aplane, Gey, Gangtok (Sikkim) ; Moshing, Chug, Shergaon (Arunachal Pradesh) ; Palni Hills (Tamil Nadu).

Field observation : The species is a mountaineous one upto the altitude of 3000 mts. They are found in deep and dampy forests. It attacks cattles and human beings.

***Haemadipsa moorei* Sanjeva Raj and Gladstone**

1981. *Haemadipsa moorei*, Sanjeeva Raj and Gladstone, *Rec. zool. Surv. India*, 79 (1-2) : 1-18.

Diagnostic characters : Size small, sucker relatively very small. Living colours, dark or chocolate brown on venter and black or dark brown on the dorsal surface with black

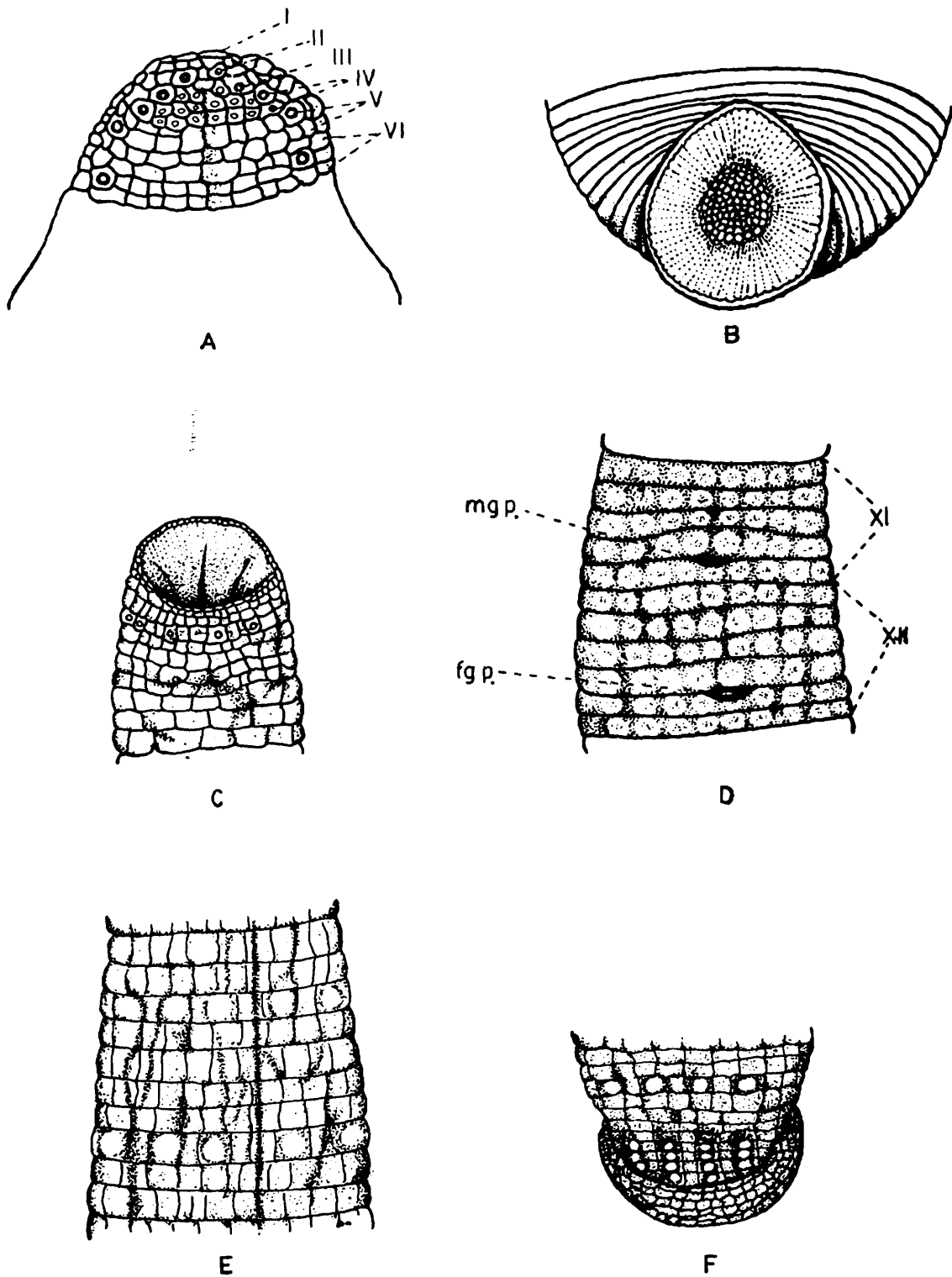

Fig.49.

Fig. 49. Diagram showing external features of *Haemadipsa moorei* Sanjeeva Raj and Gladstone.

- A. Dorsal tessellae of the head.
 - B. Ventral view of the posterior sucker showing sucker rays.
 - C. Ventral view of the anterior.
 - D. Region of the gonopores.
 - E. Dorsal view of two complete segments.
 - F. Dorsal view of posterior sucker.
- (After Sanjeeva Raj and Gladstone, 1981).

blotches or with black lines in the form of chain stripes. Venter usually mottled. Marginal yellow stripes very clear. Caudal sucker with prehensile papillae well developed. Sucker rays vary from 74 to 76 rays. Anterior portion conspicuously narrower and broader at the posterior. (Fig. 49).

Distribution : India : Nymakaud, Rajamalai of the Mannar area and Seelaliparai of the Annamalais ; Western Ghats, South India.

Field observation : The species is mostly found in the grass-lands often under the grass stems at the higher altitudes. Altitude recorded from 1500 mts to 1800 mts. They attack cattles and human beings. The bite is very painful.

Haemadipsa ornata Moore

1927. *Haemadipsa ornata* Moore, *Fauna Brit. India*, Hirudinea, 284-289. (Type-Locality : Darjeeling ; Type-Deposited : Z.S.I.).

1983. *Haemadipsa ornata*, Chandra, *Rec. zool. Surv. India*, 80 : 287.

Diagnostic characters : Size medium, form most slender among the Indian representatives of the genus. Colour in life brilliantly contrasting pattern of velvety black and light yellow or cream coloured stripes ; the black stripes, a median and a pair of intermediate much broader than the yellow, venter a rich ferruginous and suckers pale blue. Caudal sucker relatively large, rays unusually numerous 86 to 94. (Plate IV and Fig. 50).

Distribution : India : Darjeeling (West Bengal) ; Kamrup (Assam).

Field observation : The striking and handsome colouration is the field characteristic. They are found in deep and dampy forests. Its bite is very painful. They attack human beings.

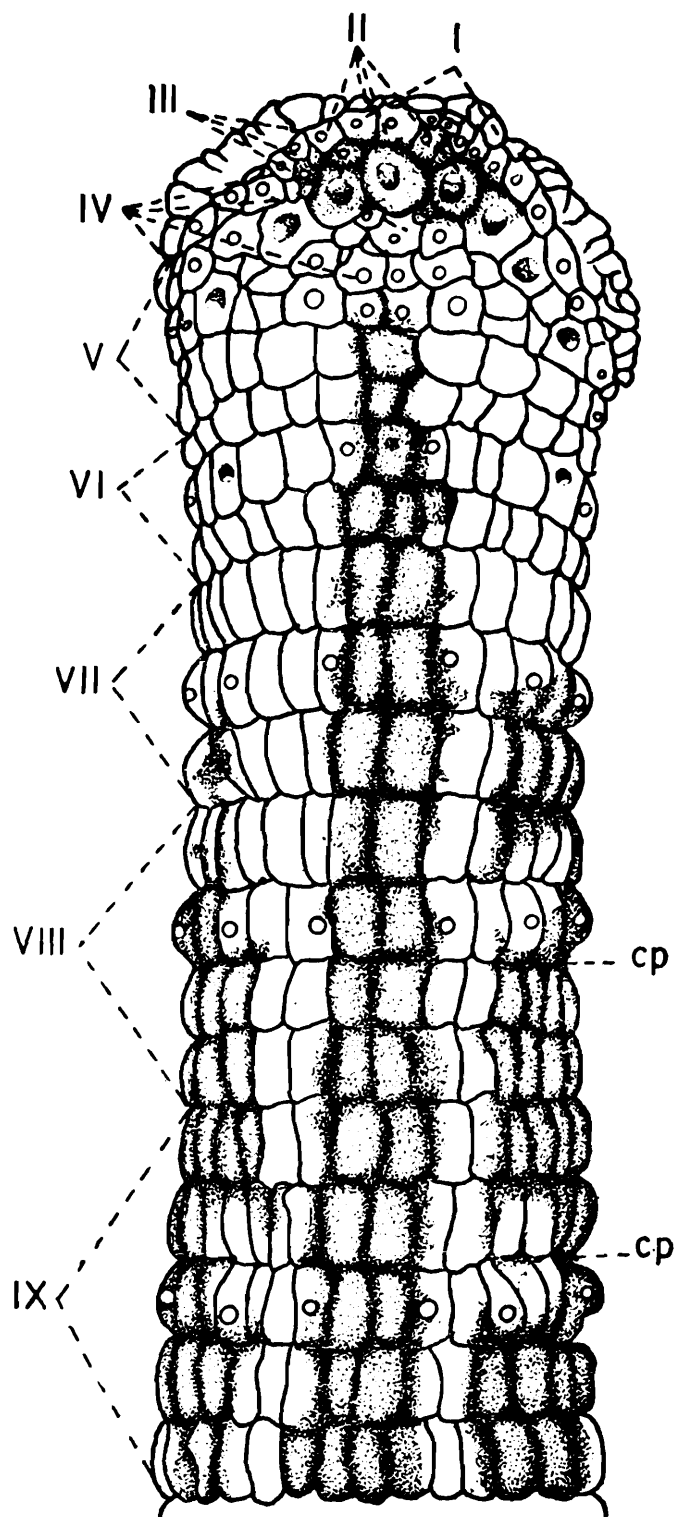

Fig. 50.

Fig. 50. *Haemadipsa ornata* Moore. Dorsal aspects of somites I-IX, showing eyes, sensillae and other sense organs; somites, annuli, aerolae, and furrowpits. (After Moore, 1927).

***Haemadipsa sylvestris* Blanchard**

1894. *Haemadipsa sylvestris* Blanchard, *Annali Mus. civ. Stor. nat. Giacomo Doria*, 2 (4) : 113-118. (Type-Locality : Carin, Burma ; Type-Deposited : Not known).
1927. *Haemadipsa sylvestris*, Moore, *Fauna Brit. India*, Hirudinea, 276-284.
1983. *Haemadipsa sylvestris*, Chandra, *Rec. zool. Surv. India*, 80 : 287.

Diagnostic characters : The most largest and robust species of the Indian land leeches. Colour plain yellow or brown of varied shades, the mid-dorsal field somewhat paler, with three black or dark-brown stripes. The median line narrower, broken or obsolete. Marginal stripes bright orange or yellow. Sucker rays 74 to 76 but varying between 69 and 80. Prehensile papilla little developed. Furrow pits four or

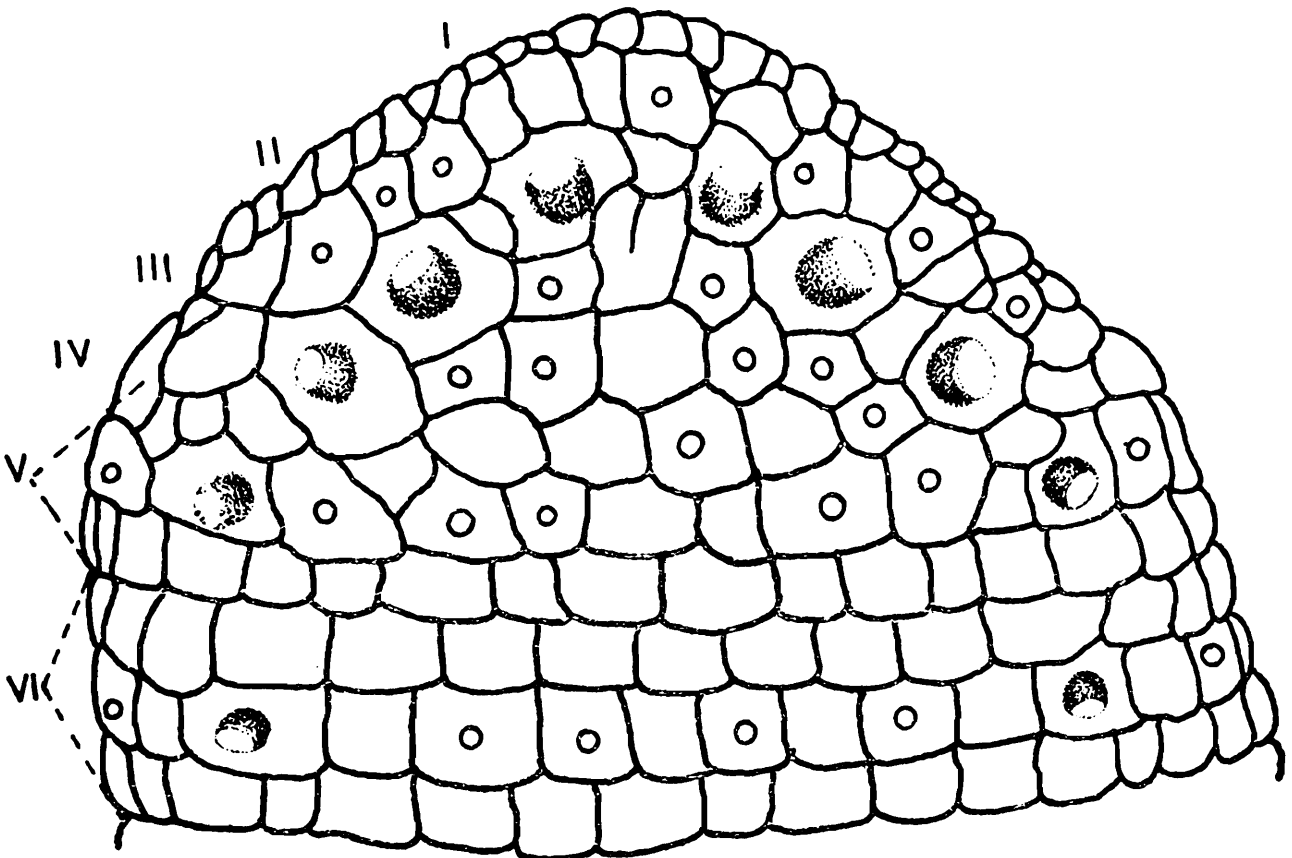

Fig. 51.

Fig. 51. *Haemadipsa sylvestris* Blanchard. Dorsal aspect of somites I-IV, showing aeration, eyes and other sense organs. (After Moore, 1927).

five pairs on VIII to XI or XII, often indicated by pale spots. (Plate V and Fig. 51).

Distribution : India : Naini Tal, Bahraich (Uttar Pradesh) ; Darjeeling, Calcutta (West Bengal) ; Cachar, Cheerapunji (Assam) ; Jhumla, Moshing, Donkochu, Shergaon, Sangloo, Domkho (Arunachal Pradesh).

Outside India : Burma, Java and Sumatra.

Field observation : Typically it is an Himalayan species. Generally they occur between 1500 mts to 2000 mts altitude. They are found throughout the year. They attack cattles and human beings. Its bite is very painful.

***Haemadipsa zeylanica agilis* Moore**

1927. *Haemadipsa zeylanica agilis* Moore, *Fauna Brit. India, Hirudinea*, 266-267.
 1983. *Haemadipsa zeylanica agilis*, Chandra, *Rec. zool. Surv. India*, 80 : 286.

Diagnostic characters : Size small, slender, cylindroid, tapering from broad sucker pedicel to the head. Colour in life light olive, yellowish-olive or brown with broad dorsal paler field and a continuous median black or dark-brown line ; elsewhere irregularly maculated, the spots are coarser and more variable both in number and size. The ventral surface is similar but paler. Marginal stripes pale yellow, white or even silvery. Furrow pits not so prominent but small depression on X to XII. Prehensile papilla variable. Sucker rays 66-76. (Plate VI).

Distribution : India : Sirmour, Chamba (Himachal Pradesh) ; Naini Tal, Almora, Kumaon, Landour, Muktesar (Uttar Pradesh) ; Arunachal Pradesh ; Poonch (Jammu and Kashmir).

Field observation : It is the common land-leech of the Western Himalayas. Its altitude is from 1,200 mts to 1,800 mts. They are found in abundance during the rainy season in deep and dampy forests and grasslands. They attack cattles and human beings.

***Haemadipsa zeylanica cochini* Moore**

1927. *Haemadipsa zeylanica cochini* Moore, *Fauna Brit. India*, Hirudinea, 265-266. (Type-Locality : Cochin, Kerala ; Type-Deposited : Z.S.I.).

1983. *Haemadipsa zeylanica cochini*, Chandra, *Rec. zool. Surv. India*, 80 : 286.

Diagnostic characters : Size small, slender and cylindroid.

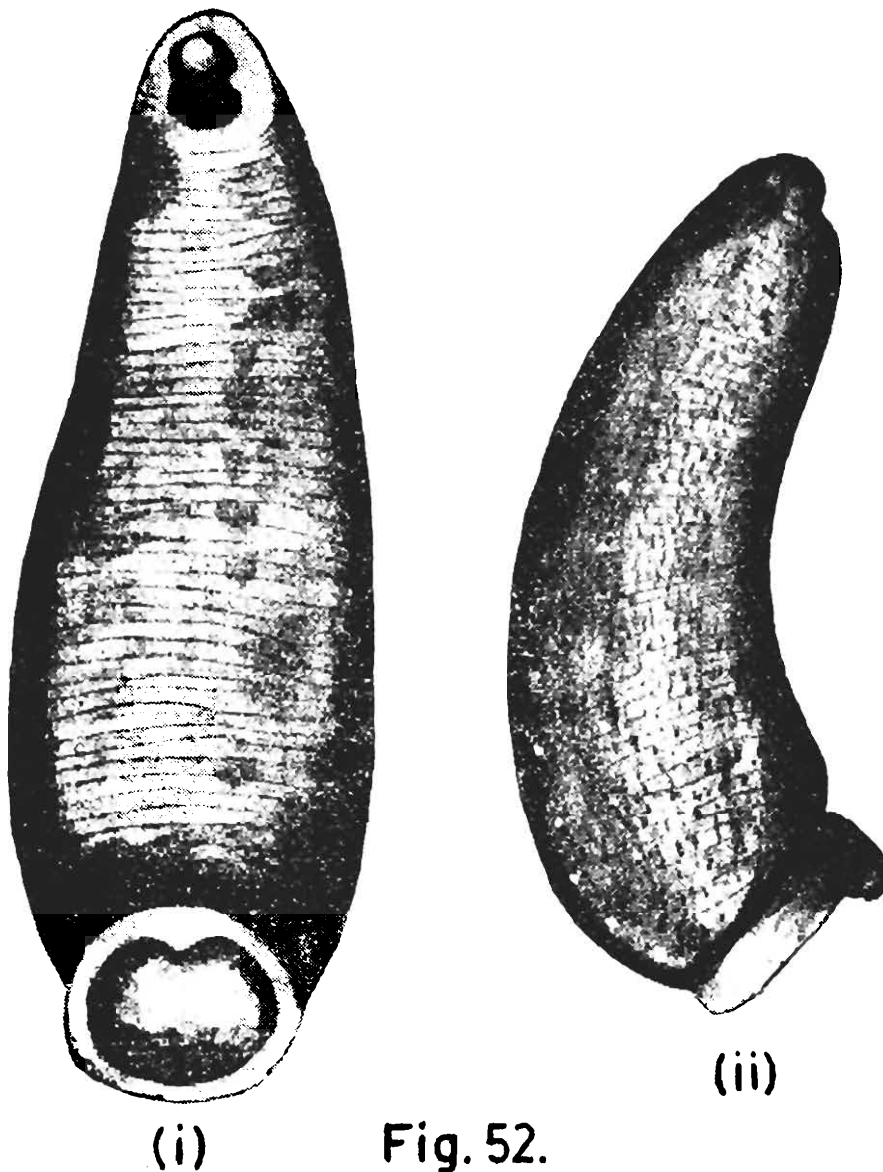

Fig. 52. *Haemadipsa zeylanica cochini* Moore. (i) Ventral view, (ii) Lateral view, to show colour-pattern and prehensile papilla. (After Moore, 1927).

Prehensile sucker papilla large and prominent, almost a permanent structure. Colour pattern mottled with black

above and below, no paler median field, but constantly a median dorsal dark stripe. The most striking character is the large size of prehensile papilla, being a large triangular, sharp pointed process strongly hooked or bent ventral ; giving the feeling of being a permanent structure. (Fig. 52).

Distribution : India : Nilgiri Hills (Tamil Nadu) ; Cohn (Kerala) ; N. Kanara (Maharashtra).

Field observation : The species is common in the extreme Southern portion of India. They range from sea-level to 800 mts in height. Generally found in deep and dampy forests. It attacks cattles and human beings.

***Haemadipsa zeylanica montivindicis* Moore**

1927. *Haemadipsa zeylanica montivindicis* Moore, *Fauna Brit. India*, Hirudinea, 267-268. (Type-Locality : Drajeeling, West Bengal ; Type-Deposited : Z.S.I.).
1983. *Haemadipsa zeylanica montivindicis*, Chandra, *Rec. zool. Surv. India*, 80 : 286.

Diagnostic characters : Size, form, annulation general morphology like *H. zeylanica zeylanica*. Colour in life olive-brown, reddish-brown or yellowish-brown, occasionally very dark ; mid-dorsal field paler with a continuous dark-brown or black median line. Black spots usually absent but a few obscure ones sometimes present ; rounded pale yellow or cream-coloured spots include the paramedian and intermediate sensillae. Marginal stripes pale yellow, cream-coloured or nearly white. Paramedian and intermediate segmental papillae very prominent and pale-coloured. Sucker rays 69 to 76 or rarely 79. (Plate VII).

Distribution : India : Darjeeling (West Bengal) ; Ghumti (Assam) ; Kalimpong (Sikkim) ; Arunachal Pradesh.

Field observation : The species predominantly belongs to Eastern Himalayas. It is found in the damp ravines and dripping forests upto 3000 mts. They attack cattles and human beings.

***Haemadipsa zeylanica zeylanica* (Moquin-Tandon)**

1826. *Sanguisuga zeylanica* Moquin-Tandon, *Monographie de la famille des Hirudinees*, Montpellier. (Type-Locality : Sri Lanka ; Type-Deposited : Not known).
1967. *Haemadipsa zeylanica zeylanica*, Soos, *Acta. zool. Hung.*, 13 (3-4) : 417-432.
1983. *Haemadipsa zeylanica zeylanica*, Chandra, *Rec. zool. Surv. India*, 80 : 285-286.

Diagnostic characters : Size small, very slender, cylindrical, tapering from the broad sucker pedicel to head. Colour variable, ground colour reddish-brown mottled or flecked with black and dorsal yellow or greenish-yellow line. Marginal stripes pale-yellow. Third and fourth pairs of

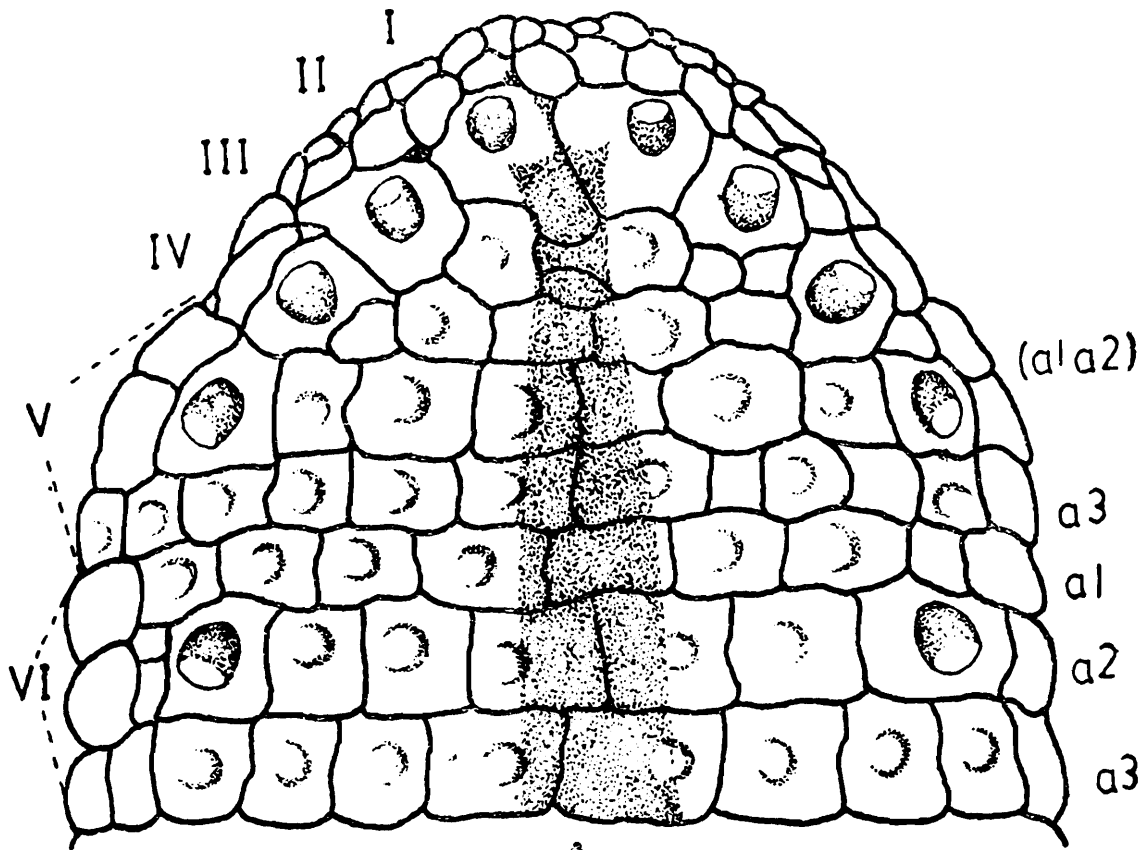

Fig. 53.

Fig. 53. *Haemadipsa zeylanica zeylanica* (Moquin-Tandon). Dorsal aspect of somites I-VI. Somites notation on left, annuli on right ; stippled band is median yellow stripe and circles, eyes.

eyes typically on contiguous annuli. Caudal sucker prehensile papilla constantly well defined. Head tessellae very regular. Sucker rays from 71-73. (Plate VIII and Fig. 53).

Distribution : India : Sirmour (Himachal Pradesh) ; Ankaling village (Arunachal Pradesh). Outside India : Sri Lanka.

Field observation : This species has an extensive range throughout the south-eastern continental Asia and Oriental Islands. It is found from sea-level to over 3000 mts in the Himalayas. They occur in marshy places and deep forests. They attack cattles and human beings. Their bite is painless.

BIBLIOGRAPHY

- Annandale, N. 1913. The leeches of the lake of Tiberias. *J. Proc. Asiat. Soc. Bengal* (n. s.) **9** (6) : 211-214.
- Apathy, S. 1890. *Pseudobranchellion margo* (Nova familia Hirudinearum). *Orvostermesztud Ertesito*, **15** : 110-113, 122-127.
- Autrum, H. 1936. *Hirudinean Bronns klassen und des Tierreicha*, **1** (1) : 1-95.
- Baird, W. 1869. Description of some new suckorial Annelids in the collections of the British Museum. *Proc. zool. Soc. Lond.*, 310-318.
- Baugh, S. C. 1960a. Studies on Indian Rhynchobdellid Leeches-I. *Parasitology*, **50** : 217-310.
- Baugh, S. C. 1960b. Studies on Indian Rhynchobdellid Leeches-II. *Zool. Anz.*, **165** : 468-477.
- Bhatia, M. L. 1930a. Sur une nouvelle hirudinee rhynchobdelle *Glossiphonia cruciata* n. sp., provenant du vivier a truites d' Achha Bal, Kashmir. *Annl's Parasit. hum. comp.*, **8** : 344-348.
- Bhatia, M. L. 1930b. On the anatomical details of *Placobdella emyde* Harding. A leech parasitic on Indian turtles. *Zool. Anz.*, **91** : 225-243.

- Bhatia, M. L. 1934. Nouvelle sangsue rhynchobdellide *Glossiphonia lobata* n. sp., de l' establishment de pisciculture d' Achha Bal, Kashmir. *Annl's Parasit. hum comp.*, 12 : 121-129.
- Bhatia, M. L. 1939. On some leeches from Kashmir. *Bull. Punj. Univ. Zool.*, 2 : 1-17.
- Bhatia, M. L. 1940. On *Haemopsis indicus* sp. nov. A new Arhynchobdellid carnivorous leech from Kashmir. *Proc. nat. Acad. Sci. India*, 10 (4) : 133-144.
- Blanchard, R. 1894. Viaggio di Leonardo Fea in Birmanica e regioni vicine-LVII. Hirudinees. *Ann. Mus. civico di Storia Naturale, Genova*, 14 (2) : 113-118.
- Blanchard, R. 1896. Description des quelques Hirudinees Asiatiques. *Mem. Soc. Zool. de France*, 9 : 316-330, 7 text-figs.
- Blanchard, R. 1897. Hirudinees des Indes Neerlandaises. *Zool. Ergeb. Reise in Neiderlandisch Ost-Indien*, 4 : 332-335, 11 text-figs.
- Blanchard, R. 1917. Monographie des Hemadipsines (Sangsues terrestres). *Bull. de la Soc. Pathologie Exotique*, 10 : 640-675, pl. vii, 16 text-figs.
- Caballeroy, C. E. 1956. Hirudineaos de Mexico : Taxynomenclatura de la class Hirudinea hasta generos. *An. Inst. Biol.*, 27 : 279-302.
- Chandra, M. 1967. Record of *Paraclepsis praedatrix* Harding, 1924 (Annelida : Hirudinea), from a new host, *Natrix piscator* (Schneider). The checkered keel back (Reptilia : Serpentes). *J. Bombay nat. Hist. Soc.*, 63 (2) : 448-449.
- Chandra, M. 1970 (1968). Notes on a small collection of leeches in the Zoological Survey of India. *Rec. zool. Surv. India*, 64 (1-4) : 107-110.
- Chandra, M. 1973. Record of *Paraclepsis praedatrix* Harding, 1924 and *Glossiphonia weberi* Blanchard, 1897 (Annelida : Hirudinea), from a new host, *Rana limnochoris* Wiegman, *Curr. Sci.*, 42 (14) : 512-513,

- Chandra, M. 1974. On the occurrence of *Glossiphonia heteroclita* (Linnaeus) (Annelida : Hirudinea) from Rajasthan, India. *Curr. Sci.*, **43** (6) : 195.
- Chandra, M. 1976a. On a small collection of leeches from Maharashtra State, India. *Rec. zool Surv. India*, **69** (1-4) : 325-328.
- Chandra, M. and Mahajan, K. K. 1976b. Leeches of Simla Hills, Himachal Pradesh. *Rec. zool. Surv. India*, **69** (1-4) : 256-259.
- Chandra, M. 1977. A check-list of leeches of Himachal Pradesh. *Rec. zool. Surv. India*, **73** (1-4) : 189-195.
- Chandra, M. 1978a. Addition to the leech fauna of Himachal Pradesh, India. *Cheetal*, **19** (2 & 3) : 25.
- Chandra, M. 1978b. Colour variation in *Haemadipsa sylvestris* Blanchard (Hirudinea : Haemadipsidae). *Cheetal*, **19** (2 & 3) : 26.
- Chandra, M. 1981. Occurrence of palearctic leech *Hemiclepsis marginata asiatica* Moore in Renuka Lake, Himachal Pradesh. *J. Bombay nat. Hist. Soc.*, **78** (3) : 625.
- Chandra, M. 1983. A check-list of leeches of India. *Rec. zool. Surv. India*, **80** : 265-290.
- Chandra, M. 1984a. Effect of high altitude factors on the leech fauna. *Proc. Wkshp. High. Alt. Ent. Wild. Ecol. zool. Surv. India*, : 345-346 (1983).
- Chandra, M. 1984b. The leech fauna of the Jammu region of Jammu and Kashmir State, India. *Rec. zool. Surv. India*, **81** (1-2) : 289-298.
- Chandra, M. Leech fauna of Kashmir region of Jammu and Kashmir State, India. *Rec. zool. Surv. India*. (In press).
- Chandra, M. And Mukherjee, R. N. 1985. Occurrence of *Piscicola olivacea* Harding (Annelida : Hirudinea) in Laddak, J. and K., India. *Bull zool. Surv. India*, **7** (2-3) : 327.

- Chelladurai, J. E. 1934. On a new Indian leech *Hemiclepsis viridis* sp. nov. *Rec. Indian Mus.*, **36** : 345-352.
- De Silva, P. H. D. H. 1963. *Zeylanicobdella arugamensis* gen. nov. and sp. nov. from Arugam Kalapu, Eastern Province, Ceylon. *Spolia zeylan.*, **30** (1) : 35-38.
- Harding, W. A. 1909. Note on two new leeches from Ceylon. *Proc. Camb. phil. Soc.*, **15** : 233.
- Harding, W. A. 1920. Fauna of the Chilka Lake : Hirudinea. *Mem. Indian Mus.*, **5** (7) : 510.
- Harding, W. A. 1924. Descriptions of some new leeches from India, Burma and Ceylon. *Ann. Mag. nat. Hist.*, **9**, **14** : 439.
- Harding, W. A. And Moore, P. J. 1927. *The fauna of British India, Hirudinea*. Taylor & Francis, London.
- Jayadev Babu, S. 1967. Two new fish-leeches from Pulicate Lake. *Curr. Sci.*, **36** (2) : 548-549.
- Julka, J. M. And Ghosh, G. 1976. On a collection of leeches from Chhota Nagpur. *Newl. Zool. Surv. India*, **2** (1) : 27-29.
- Julka, J. M. And Chandra, M. 1980. On a small collection of leeches collected during the Daphabum and Subansiri expeditions, Arunachal Pradesh. *J. Bombay nat. Hist. Soc.*, **77** : 160-161.
- Kaburaki, T. 1921a. On some leeches from the Chilka Lake. *Mem. Indian Mus.*, **5** (9) : 661.
- Kaburaki, T. 1921b. Note on the leech *Limnatis nilotica*. *Rec. Indian Mus.*, **18** : 213-214, pl. V.
- Kaburaki, T. 1921c. Notes on some leeches in the collection of the Indian Museum. *Rec. Indian Mus.*, **22**, (5) : 689.
- Lesson, J. P. 1842. Description d'une nouvelle espece de Sangsue. *Revue Zoologique Societe Cuvierieme*, ; 8.
- Linnaeus, C. 1758. *Systema Naturae*, 10th ed.
- Linnaeus, C. 1761. *Fauna Suecica*, 2nd ed.

- Mahajan, K. K. And Chandra, M. 1976. On a collection of leeches from Rajasthan, India. *Rec. zool. Surv. India*, 71 : 143-148.
- Moore, J. P. 1898. Leeches of the U. S. National Museum. *Proc. U. S. natn. Mus.*, 21 (1160) : 543-563, pl. xi, 8°. Washington.
- Moore, J. P. 1924. Notes on some Asiatic Leeches (Hirudinea), principally from China, Kashmir and British India. *Proc. Acad. nat. Sci. Phillad.*, 81 : 343-388, pls. xix-xxi.
- Muller, O. F. 1774. *Vermium terrestrium et fluviatilium*, 1(2).
- Oka, A. 1917. Zoological Results of a tour in the Far East. pt. iii, Hirudinea. *Mem. Asiat. Soc. Bengal*, 6 : 159-176,, pl. vii.
- Oka, A. 1922. Hirudinea from the Inle Lake, S. Shan States, Burma. *Rec. Indian Mus.*, 24(4) : 521.
- Sanjeeva Raj, P. J. 1951. On a new species of *Ozobranchus* (Annelida : Hirudinea : Ichthyobdellidae) from Porto Novo, S. India. *J. zool. Soc. India*, 3 : 1-5.
- Sanjeeva Raj, J. P. 1953. First record of an ichthyobdellan leech *Branchellion pinnatum* Savigny from the Indian waters. *Curr. Sci.*, 22(10) : 310.
- Sanjeeva Raj, J. P. 1954. A synopsis of the genus *Ozobranchus* de Quatrefagus, 1852, (Hirudinea : Annelida). *J. Bombay nat. Hist. Soc.*, 52 : 473-480.
- Sanjeeva Raj, J. P. 1959. Occurrence of *Ozobranchus margo* (Apathy) (Hirudinea : Annelida) in the Indian Seas. *Curr. Sci.*, 28 : 496.
- Sanjeeva Raj, J. P. 1976 (1974). Review of fish-leeches of the Indian ocean. *J. mar. biol. Ass. India*, 16(2) : 351-397.
- Sanjeeva Raj, J. P. 1981. On a new species of the land leech of the genus *Haemadipsa* Tennents, from the Peninsular India. *Rec. zool. Surv. India*, 79(1-2) : 1-18.
- Savigny, J. C. 1920 (1922). *Système des Annelides*, Paris.

- Schmarda, L. F. 1861. *Neue Turbellarien, Rotatorian und Anneliden*. Leipzig. 2te Halfte. Leeches, pp. 2-7, Taf. xvi.
- Soos, A. 1965. Identification key to the leech (Hirudinoidea) genera of the world, with a catalogue of the species I. Family : Piscicolidae. *Acta Zoologica*, 11(3-4) : 417-463.
- Soos, A. 1966. Identification key to the leech (Hirudinoidea) genera of the world, with a catalogue of the species III, Family : Eropbdellidae. *Acta zool. hung.*, 12 : 371-407.
- Soos, A. 1967a. Identification key to the leech (Hirudinoidea) genera of the world, with a catalogue of the species IV. Family : Haemadipsidae. *Acta. zool. hung.*, 13(4-4) : 417-432.
- Soos, A. 1967b. On the genus *Hemiclepsis* Vejdovsky, 1884, with a key and catalogue of the species (Hirudinoidea). *Opusc. zool. Bpest.*, 7(1) : 233-240.
- Soos, A. 1967c. On the genus *Batracobdella* Viguir, 1879, with a key and catalogue to the species (Hirudinoidea : Glossiphonidae). *Annl's hist. Mus. natn. hung.*, 59 : 243-257.
- Soos, A. 1969. Identification key to the leech (Hirudinoidea) genera of the world, with a catalogue of the species VI. Family : Glossiphonidae *Acta. zool. hung.*, 15 (3-4) : 397-454.
- Soos, A. 1970. A Zoogeographical sketch of the fresh-water and terrestrial leeches (Hirudinoidea). *Opusc. zool. Bpest.*, 10 (2) : 313-323.
- Soota, T. D. 1959 (1956). Fauna of the Kashmir Valley-Leeches. *Rec. Indian Mus.*, 54 (1-2) : 1-4.
- Wahlberg, R. F. 1856. *Ofversigt Kongl. Vet. Akad. Forh*, 1855, pp. 233-234.

INDEX TO SCIENTIFIC NAMES

All numerals refer to page numbers in the Handbook. Those in bold face indicate the page numbers where the details of the species is also available.

- Arhynchobdellae 9
- Barbronia
weberi 69, **70**, 71
- Batracobdella **27**
hardingi **27**, **28**
lobata **27**, **29**, 30
mahabiri **27**, **29**, 31
reticulata **27**, **32**, 33
- Branchellion **10**
plicobranchus **10**, 11
- Dina
- Dinobdella **80**, **81**
ferox **80**, **81**, **82**
notata **80**, **83**, **84**
- Erpobdella 69
octoculata 69, **72**, 73
- Erpobdellidae
- Eubranchella 12
- Foraminobdella 69, **72**, 74
heptamerata 69, 72
- Glossiphonia 26, **32**
annandalei 26, **32**, 34
complanata
complanata 26, **35**
cruciata 26, **37**, 38
heteroclita 26, **37**, 39
weberi
weberi 26, **40**, 41
- Glossiphonidae
- Haemadipsa 98, **99**
dussumieri 98, **99**
montana 98, **99**, 100
- moorei 98, **101**, 102
ornata 98, **103**, 104
sylvestris 98, **105**
zeylanica 98
agilis, 98, **106**
cochiniana 98, **107**
montivindicis 90, **108**
zeylanica 98, **109**
- Haemadipsidae
- Haemopsis **80**, **84**
indicus **80**, **84**, 85
- Helobdella 26, **42**
nociva 26, **46**, 43
stagnalis 26, **42**, 45
- Hemiclepsis **27**, **44**
bhatiai **27**, **44**, 46
marginata 27
asiatica **27**, 47, **48**
marginata **27**, **48**, 49
viridis **27**, 50, **51**
- Herpobdelloidea **69**, **75**
lateroculata 69, **75**, 76, **77**
- Hirudidae
- Hirudinaria
- Hirudo **81**, **86**
asiatica **81**, **86**, 87
birmanica **81**, **88**
- Myxobdella **80**, **89**
annandalei **80**, **89**, 90
- Nematobdella **69**, **77**
indica 68, **77**, 78, 79
- Ozobranchus **10**, **12**

- branchiatus 10, 12
- margoi 10, 13
- polybranchus 10, 13, 14
- shipleyi 10, 15, 16
- Paraclepsis 26, 51
 - praedatrix 26, 52, 53
 - vulnifera 26, 52, 54
- Piscicola 9, 15
 - caeca 9, 15, 17
 - olivacea 9, 18, 19
- Piscicolidae
- Placobdella 25, 55
 - ceylanica 26, 55
 - emydae 25, 56, 57
- fulva 26, 56, 58
 - horai 25, 59, 60
 - indica 25, 59, 61
 - undulata 26, 62, 63
- Poecilobdella 68, 81, 91
 - granulosa 68, 81, 91
 - javanica 81, 92, 93
 - manillensis 81, 92
 - viridis 81, 94, 95
- Pontobdella
- Pontobdellina 9, 18
 - macrothela 9, 20, 21
- Protoclepsine
- Pseudobranchellion 13
- Pterobdella 9, 20
 - amara 9, 20, 22
- Rhynchobdellae
- Sanguisuga 92
- Theromyzon 27
 - mathai 27, 64, 65
 - sexoculata 27, 65, 66
- Whitmania 80, 95
 - laevis 80, 96, 97
- Zeylanicobdella 10, 23
 - arugamensis 10, 23, 24



PLATE.I. (a)

Plate I(a). *Dinobdella fero* (Blanchard). Dorsal view



(i)



(ii)

PLATE I. (b).

Plate I(b). *Poecilobdella granulosa* (Savigny).

(i) Dorsal view (ii) Ventral view (After Moore, 1927).



Plate II. *Poecilobdella javanica* (Wahlberg). (i) Dorsal view (ii) Ventral view
(After Moore, 1927)

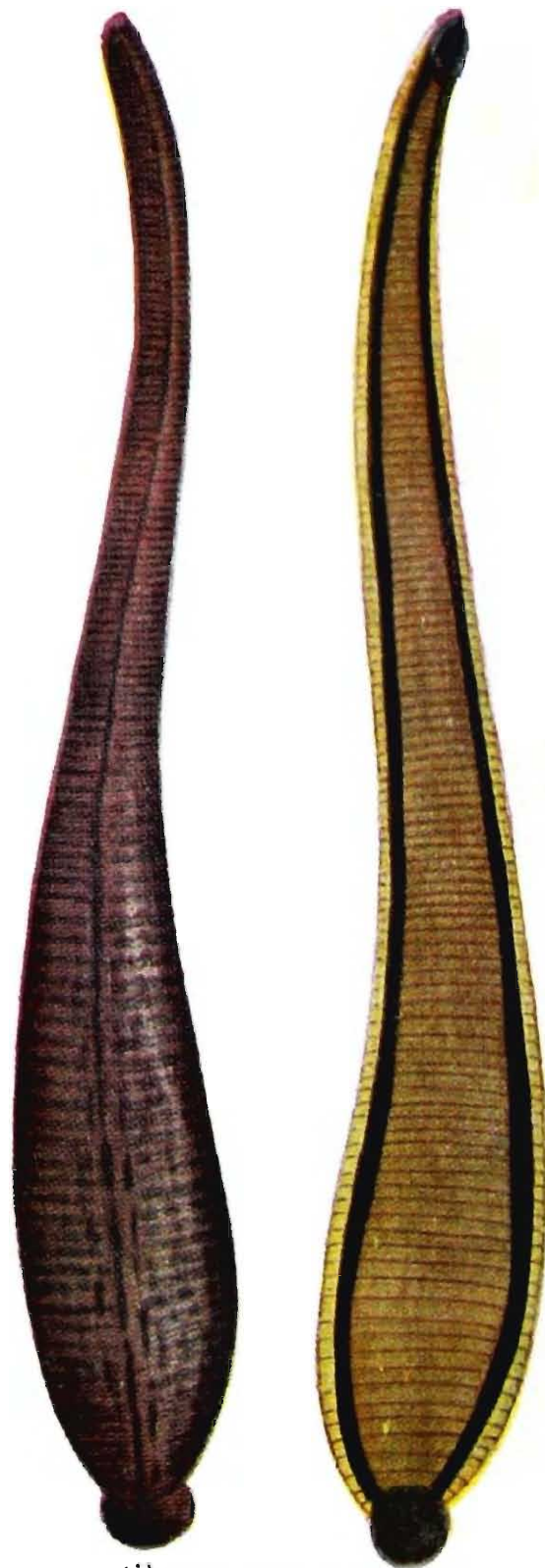

(i) PLATE III (ii)

Plate III. *Poecilobdella manillensis* (Lesson) (i) Dorsal view (ii) Ventral view
(After Moore, 1927)

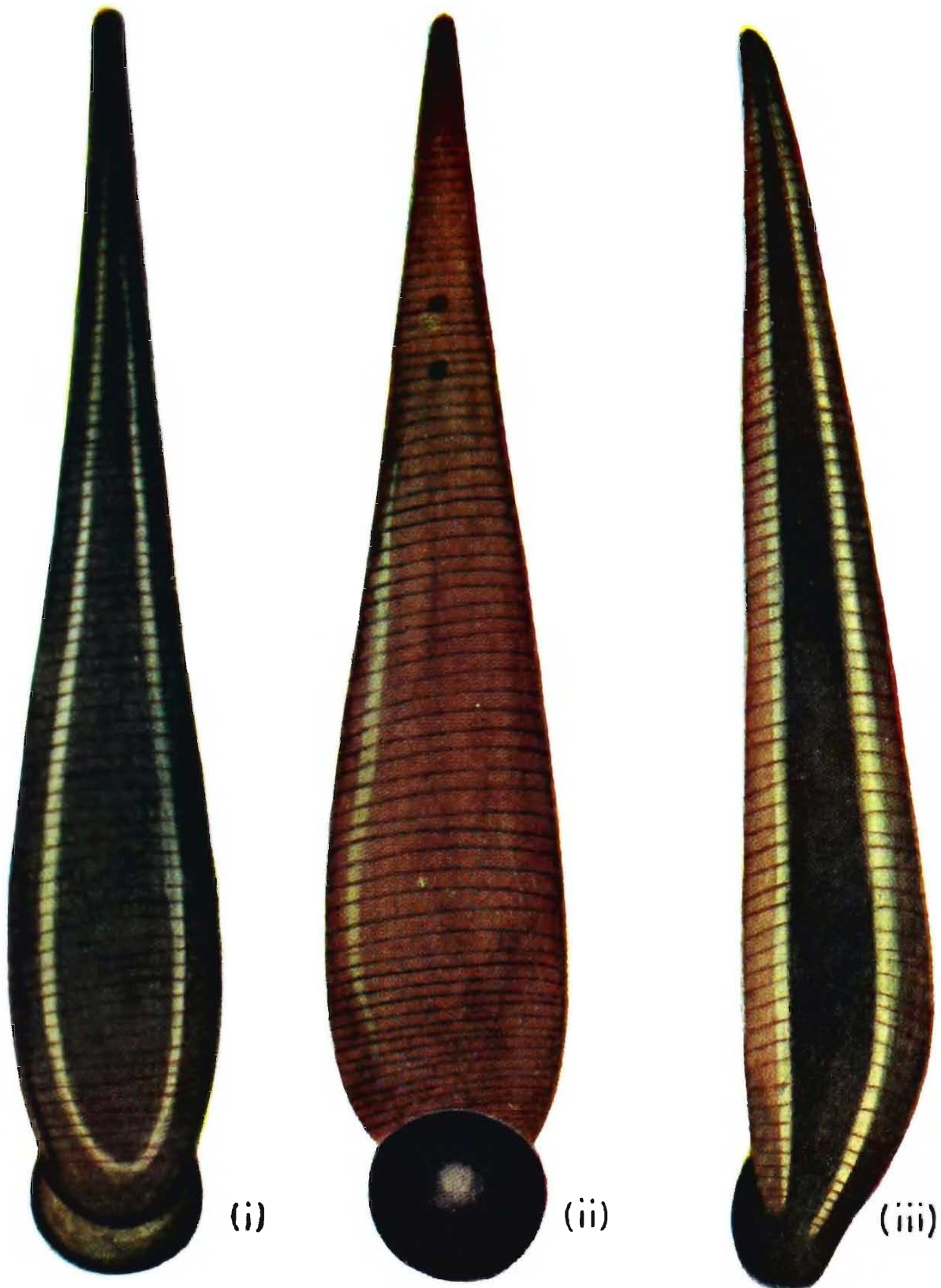

PLATE. IV.

Plate IV. *Haemadipsa ornata* Moore (i) Dorsal view (ii) Ventral view and (iii) Lateral view (After Moore, 1927)

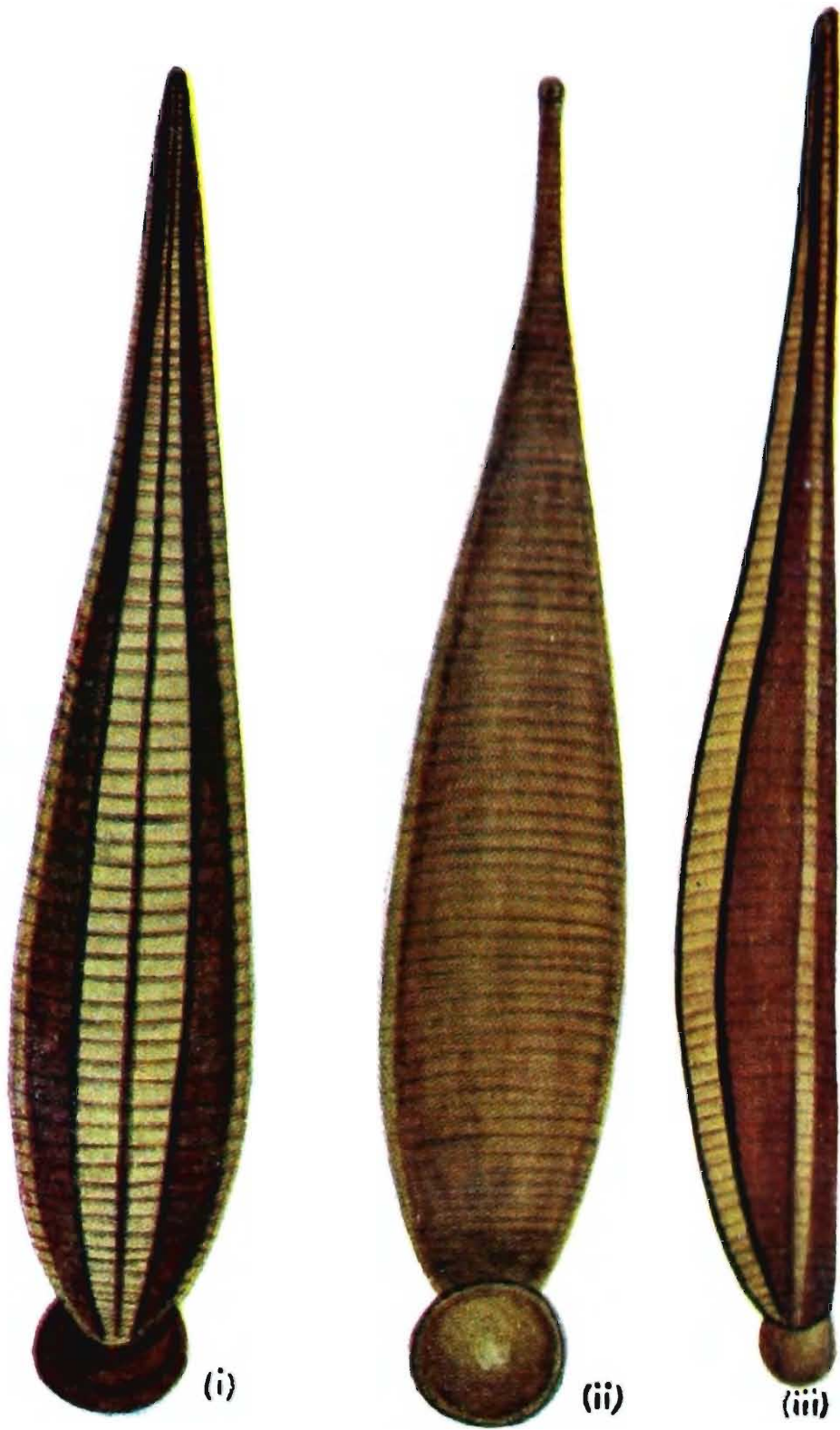

PLATE.V.

Plate V. *Haemadipsa sylvestris* Blanchard (i) Dorsal view (ii) Ventral view and (iii) Lateral view (After Moore, 1927)



PLATE.VI.

Plate VI. *Haemadipsa zeylanica agilis* Moore (i) Dorsal view (ii) Ventral view and (iii) Lateral view (After Moore, 1927)

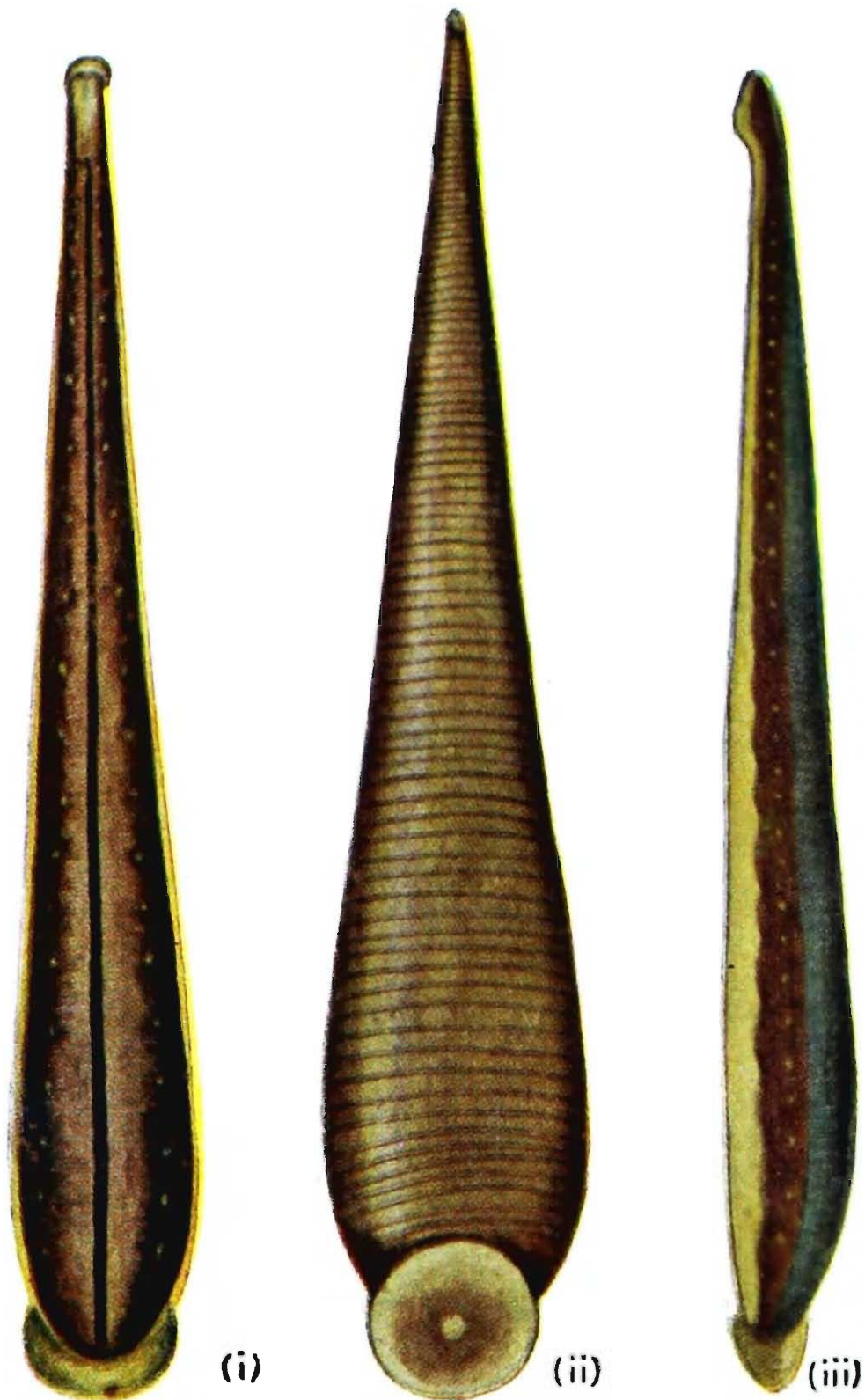
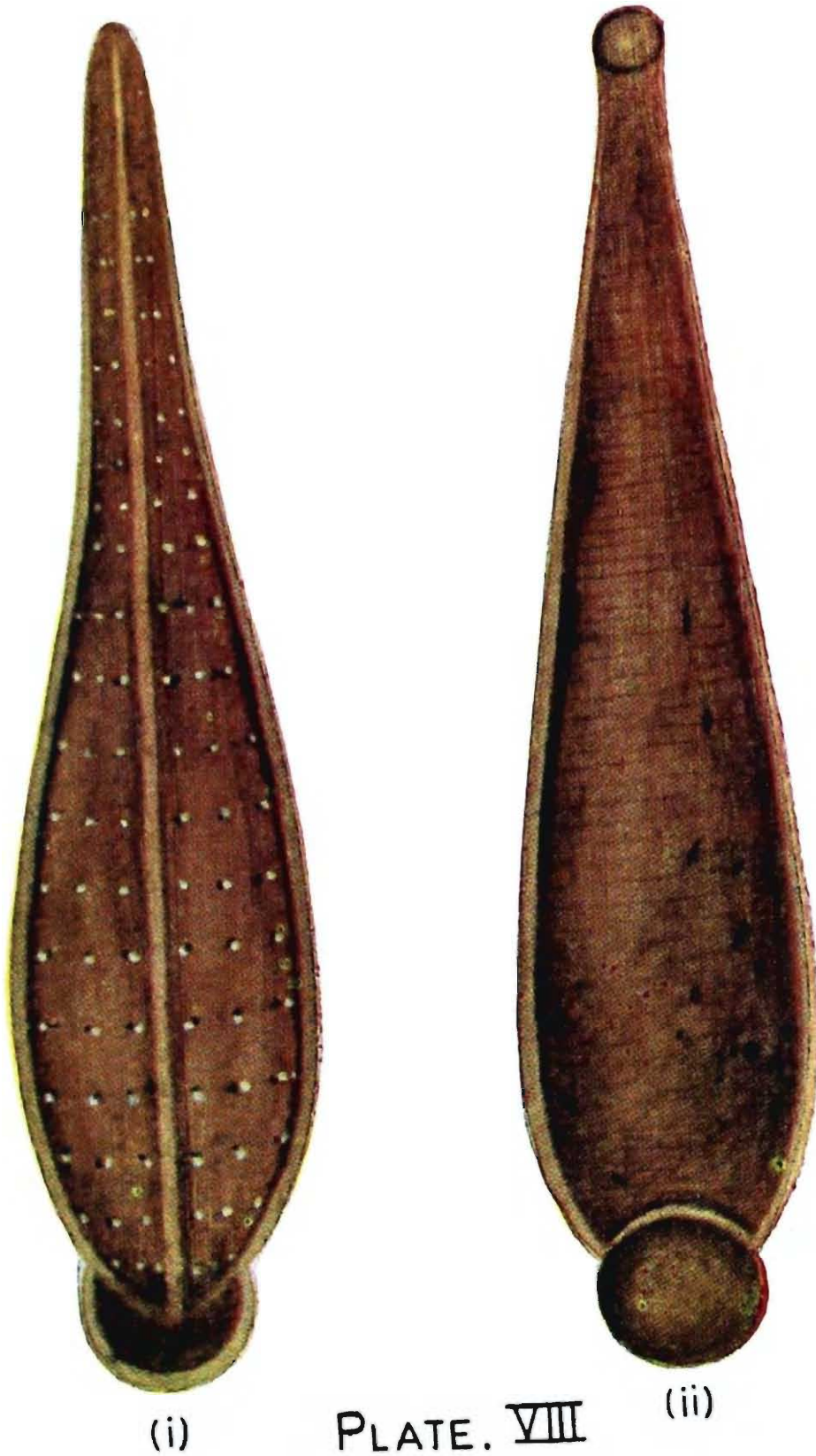

PLATE. VII.

Plate VII. *Haemadipsa zeylanica montivindicis* Moore (i) Dorsal view (ii) Ventral view and (iii) Lateral view (After Moore, 1927)



late VIII. *Haemadipsa zeylanica zeylanica* (Moquin-Tandon)
(i) Dorsal view (ii) Ventral view (After Moore, 1927)