

COLLECTION AND PRESERVATION. OF ANIMALS.

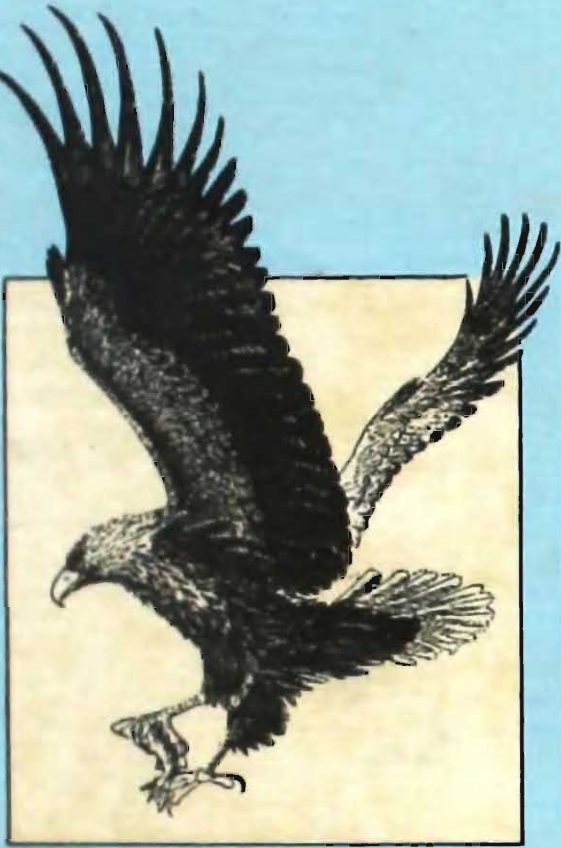

LOGICAL SURVEY OF INDIA

COLLECTION AND PRESERVATION OF ANIMALS

Edited by
Director, Zoological Survey of India



ZOOLOGICAL SURVEY OF INDIA
1990

© Copyright, 1990 Government of india

Published : November, 1990

**Published by
The Director, Zoological Survey of India, Calcutta**

**Laser set by Neatpoint Photocomposers
6A Sudder Street, Calcutta 700 016 and printed
by Sun Lithographing Co., Calcutta 700 010**

Preface

This *Handbook* is primarily intended as a guide for collection and preservation of animals for taxonomic studies. It is usually seen that most specimens sent for identification to the Zoological Survey of India are in a condition which even specialists of the group find difficult to identify. This is due to the lack of knowledge of collecting and preserving the different groups according to certain well laid out procedures. Hence, many valuable species are lost to science.

To overcome this difficulty, each group is dealt by a specialist who himself has collected, preserved and studied them. So the individual scientist's vast experience in the field has gone into this handbook.

This practical guide will be of use not only to taxonomists but also to naturalists who collect animals for pleasure or study. If the methods and procedures in this book are followed, we shall be in a much better way equipped to identify the specimens. After following the packing and labelling procedures, all packets should be addressed to: The Director, Zoological Survey of India, 234/4 A.J.C. Bose Road, Nizam Palace Complex (14th Floor), Calcutta-700020 and sent by registered post.

I am thankful to Drs. V. C. Agrawal, A. K. Mandal and T. Sengupta for the help in collecting the articles and revising this Handbook and also to Dr. J. R. B. Alfred and our

Publication Production Officer, Shri G. Shivagurunathan, who worked very hard to bring out this book.

We have tried to keep the book in a form suitable to be carried in the field. We shall be very grateful to readers if they will be kind enough to suggest improvements.

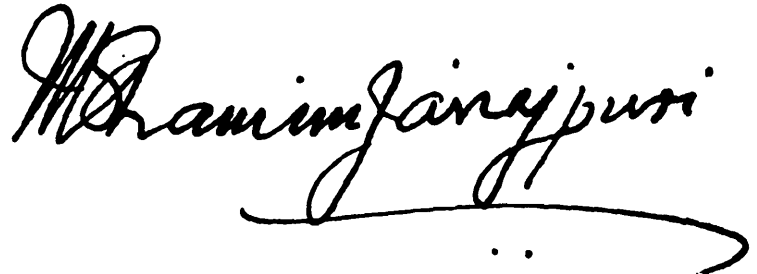
A handwritten signature in black ink, reading 'Mohammad Shamim Jairajpuri'. The signature is written in a cursive style with a long, sweeping underline that extends to the right.

Prof. Mohammad Shamim Jairajpuri
Director
ZOOLOGICAL SURVEY OF INDIA

November 1990
Calcutta

Contents

Preface

M S Jairajpuri

Protozoa and Mesozoa

A K Mandal, A K Das and N C Nandi 1

Marine Invertebrates

B P Halder, D R K Sastry and A Misra 19

Platyhelminthes

C B Srivastava and R K Ghosh 29

Nematoda, Acanthocephala and Gordiacea

Q H Baqri 43

Annelida

J M Julka 57

Crustacea

Maya Deb and P Krishnamurthy 65

Introduction to Insects

A K Ghosh 71

Collection and Museum Equipment

T Sengupta 81

Thysanura

V D Srivastava 85

Diplura

V D Srivastava 87

Protura				
V D Srivastava	89
Collembola				
V D Srivastava	91
Ephemeroptera				
V D Srivastava	93
Odonata				
V D Srivastava	95
Plecoptera				
S K Ghosh	97
Phasmida				
G K Srivastava	99
Orthoptera				
S K Tandon	101
Dermaptera				
G K Srivastava	105
Embioptera				
V D Srivastava	107
Dictyoptera				
G K Srivastava	109
Isoptera				
G K Srivastava	111
Zoraptera				
V D Srivastava	113
Psocoptera				
V D Srivastava	115

Phthiraptera				
G K Srivastava	117
Hemiptera				
R K Varshney	119
Thysanoptera				
S K Ghosh	125
Neuroptera				
S K Ghosh	127
Mecoptera				
V D Srivastava	129
Lepidoptera				
G S Arora	131
Trichoptera				
S K Ghosh	139
Diptera				
A N T Joseph	141
Siphonaptera				
G K Srivastava	145
Hymenoptera				
J K Jonathan	147
Coleoptera				
T Sengupta and P Mukhopathyay	151
Strepsiptera				
S K Ghosh	151
Acari				
S K Gupta	161

Mollusca				
N V Subba Rao	173
Hemichordata and Protochordata				
P Dhandapani	183
Fishes				
A G K Menon	191
Amphibia				
R S Pillai and M S Ravichandran	195
Reptilia				
M N Acharji	199
Aves				
P K Das	203
Mammalia				
V C Agrawal	215

Protozoa and Mesozoa

Protozoa

The subkingdom Protozoa encompasses single celled eukaryotic animalcules of microscopic size, ranging mostly between 5 μm and 250 μm . There are, however, several protozoan species whose size exceeds 500 μm (e.g. giant amoeba, *Pelomyxa*) and in some exceptional cases even 5000 μm (e.g. some foraminifera, *Cycloclypeus carpenteri* and plasmodia of *Myxobolus*). Protozoa is not a natural group but comprises a highly heterogenous assemblage of seven phyla, viz., Sarcomastigophora, Labyrinthomorpha, Apicomplexa, Microspora, Ascetospora, Myxozoa and Ciliophora. These animals with very simple to most complicated life cycles occupy multifarious habitats and lead a diversified mode of life, such as free living, parasitic or symbiotic. It is, therefore, quite inevitable that collection and preservation of protozoa require special efforts and techniques not only depending upon the group of protozoans to be collected but also on the type of study to be undertaken. Even for taxonomic studies of protozoa many modern techniques have been developed, for the application of which costly instruments and sophisticated laboratory are essential. In the present communication, however, emphasis has been given on those techniques which can be adopted conveniently in the field laboratory for the general collection of protozoa.

Ecological categories (Habitat-wise)

Ecologically Protozoa may broadly be categorised as follows :

Free-living

- i. Freshwater/brackishwater/marine water forms
- ii. Soil-inhabiting forms
- iii. Moss/plant-inhabiting forms

Symbiotic

Termite flagellates and rumen ciliates

Commensals

- i. Ectocommensals
- ii. Endocommensals

Parasitic

- i. Lumenicolous
- i. Histozoic
- iii. Coelozoic

Habitat

Protozoa live in all natural conditions where moisture is found. Protozoa may be collected habitat-wise or group-wise. The former method is adopted for general collection whereas the latter for specialised collection.

For free-living Protozoa the following habitats are likely to be the valuable source of material.

- i. Any freshwater body preferably with sufficient vegetation and rich decaying organic matter, more particularly scum, debris, bottom ooze, aquatic

vegetation occupying bottom, middle and upper layers, and edges of the water body.

- ii. Brackish and marine waters and their bottom ooze.
- iii. Green scum of mudflats and moist soils between 12 and 17 cm from the surface.
- iv. Sphagnum, ground, wall and tree moss, moist plant surface, etc.

For parasitic, symbiotic and commensal Protozoa various tissues and organs of vertebrates and invertebrates are to be thoroughly examined. Even some parasitic Protozoa are found in other Protozoa (e.g. some *Endamoeba* live inside *Oplina*) as well as in plants (e.g. *Labyrinthula* parasitise many aquatic plants).

Collection

Free-living forms :

- i. *Freshwater Protozoa :* For freshwater Protozoa samples are to be taken in wide-mouthed glass jar along with some algae, water weeds, flocculent matter and bottom ooze from the source. The sampling jars are preferably to be filled up to two-third of their capacity. Plankton nets and sieves of suitable mesh-size can also be used for the collection of fresh water forms.

After bringing the sampling jars in the laboratory lids are to be immediately removed. These jars should be placed near a well lighted window from where moderate light should reach the sample. Under microscope some

protozoa may be observed immediately. But, only after 24 to 48 hours many species of Protozoa can be collected by pipetting the water sample touching the edge of the leaves or margin of stems. Others, more particularly testacid rhizopods will be available in the bottom ooze either in live condition or as dead tests (shells). Freshwater Protozoa are found to emerge in succession in the sample so that one species, found numerous and dominant one day, may be absent or meagre next day and replaced by other species. For this reason sampling jars are to be kept for a few weeks and protozoans occurring in them to be examined regularly for qualitative collection.

- ii. *Marine Protozoa* : Marine Protozoa can be collected by plankton and other nets, towing slowly behind the boat. These are to be kept in sampling jars and brought to the laboratory and above mentioned methods are followed for their extraction. Some samples may be preserved in 4% formaldehyde solution in the field and brought to the laboratory for extraction and study of protozoa occurring in them.
- iii. *Soil Protozoa* : For the collection of soil Protozoa soil samples are to be taken from a patch of soil, making 12-17 cm deep borings. The samples are to be mixed, sieved through a sieve of 3 mm mesh-size, stored in sterile bottles and brought to the laboratory for microscopical examination and/or culture.
- iv. *Moss-inhabiting and other free-living Protozoa* : Protozoan species can be collected from specific

habitats *viz.*, moss, fungi, aquatic plants, etc. these protozoans are collected or cultured along with plants.

Symbiotic, commensal and parasitic forms :

Symbionts, commensals and parasites are collected by scraping the body-portion of the hosts, harbouring these forms. Intestinal, histozoic and coelozoic forms are collected by dissecting the body parts of the hosts and subsequently by microscopical examinations of the gut content, organ-smears, blood-smears, faeces, etc. Sterilisation of the instruments and use of physiological saline are essential for the purpose.

Chemicals and reagents, fixatives and stains required

The widely used fixatives, stains and reagents for the taxonomic studies of protozoa are listed below for the convenience of the beginners on the subject.

Fixatives

1. *Schaudinn's fluid*

Cold saturated mercuric chloride	66 ml
Absolute or 95% alcohol	33 ml
Glacial acetic acid	1 ml

2. *Carnoy's fluid*

Absolute alcohol	30 ml
Glacial acetic acid	10 ml

3. *Bouin's fluid*

Picric acid (saturated)	75 ml
Formaldehyde (commercial)	25 ml
Glacial acetic acid	5 ml

4. *Zenker's fluid*

Potassium dichromate (2.5% aqueous)	100 ml
Sodium sulphate	1 gm
Mercuric chloride	5 gm
Glacial acetic acid	5 ml

5. *Carnoy's acetic alcohol*

Absolute alcohol	3 parts
Glacial acetic acid saturated with iron acetate	1 part

*Stains*1. *Heidenhain's haematoxylin*

Haematin powder	0.5 gm
Absolute alcohol	10 ml
Distilled water	100 ml

2. *Giemsa stain powder*

Acetone free absolute methyl alcohol	0.6 gm
Alcohol	50 ml
Glycerin	50 ml

3. *Wright's stain*

Dry stain, certified powder	0.3 gm
Glycerine, C. P. neutral	3 ml
Acetone free absolute methyl alcohol	97 ml

Solutions**1. Buffer solution****Stock Solution A (M/15 Disodium phosphate)**

Anhydrous disodium phosphate (Na_2HOP_4)	9.5 gm
Distilled water to make	1000 ml

Stock Solution B (M/15 Monosodium phosphate)

Monosodium phosphate ($\text{NaH}_2\text{PO}_4 \cdot \text{H}_2\text{O}$)	9.2 gm
Distilled water to make	1000 ml

Buffer water (pH 7.0) for blood stain

M/15 Disodium phosphate	61.1 ml
M/15 Monosodium phosphate	38.9 ml
Distilled water	900 ml

Physiological salines

	<u>For vertebrate parasites</u>		<u>For inver-</u>
	<i>Poikilo-</i>	<i>Homoio-</i>	<i>tebrate</i>
	<i>therms</i>	<i>therms</i>	<i>parasites</i>
i. Normal saline			
Sodium chloride	7 gm	8.5 gm	5.6 gm
Distilled water	1000 ml	1000 ml	1000 ml
ii. Ringer's solution			
(for poikilotherm parasites)			
Sodium chloride			8 gm
Sodium bicarbonate			0.2 gm
Potassium chloride			0.2 gm
Calcium chloride			0.2 gm

Dextrose (may be omitted)	1 gm
Distilled water	1000 ml
iii. <i>Locke's solution</i> (for homoiotherm parasites)	
Sodium chloride	9 gm
Sodium bicarbonate	0.2 gm
Potassium chloride	0.42 gm
Calcium chloride	0.25 gm
Dextrose	2 gm
Distilled water	1000 ml

Besides the chemicals mentioned above, a few other chemicals are also needed for the collecting of protozoa. These are ferric ammonium sulphate (iron alum), silver nitrate, alcohol of various grades, caustic potash, chloral hydrate, ferric chloride, menthol, Lugol's solution, Methocel, potassium dichromate, iodine crystals, xylol, DPX and glycerine.

Equipments required

In addition to the conventional laboratory articles such as glass vials, specimen tubes and jars, petri dishes, beakers, culture dishes, embryo flasks, finger bowls, micropipettes and rubber teats, dissecting box, spirit lamp, chemical balance, measuring cylinder, filter paper, glass marking pencil, etc., the following items are specially required :

Microscope, Dissecting binocular, Centrifuge with buckets and tubes, microslides of high quality, coverslip (no 1 thickness), cavity block, couplin jars, slide box and cabinet,

Hot plates, Hot bath, Autoclave, Incubator, Microtome, microsieves, plankton net, pile scrape net and dip net (for the collection of free-living protozoa).

Examination of live material

For taxonomic study it is often essential to observe live protozoans before preservation because in many cases certain important diagnostic features of the animal may not be visible after preservation.

Unstained preparation

Free-living and lumenicolous forms can be observed by keeping them in a drop of their natural medium of physiological saline on clean slide or cavity block (for longer observation). For slowing down the movement of free-living protozoa, Methocel solution (10 gm of methyl cellulose is mixed with 45 ml of boiling water, after allowing that water to soak for 20 minutes, 45 ml of cold water is then added and the solution is cooled to 10°C and kept in drop bottles) is most suitable. For that purpose a small ring of the Methocel is made on the slide. Then a drop of culture/sample is placed in the centre of the ring and covered with a cover-slip.

Stained preparation

- i. To observe live protozoans under stained condition intra-vitam stains such as neutral red or methyl blue (0.01%) may be used. A drop of stain is poured on the slide and allowed to dry. Then a drop of sample is placed on the stained area and covered with a coverslip.

- ii. Lugol's iodine solution (Potassium iodide 1.5 gm, iodine 1 gm, distilled water 25 ml) is used to stain nuclei of cysts and their internal structures.

Preservation

This can be done either as permanent slides or as cultures.

Preparation of permanent slides

This involves fixation, staining, differentiation, dehydration and mounting in a neutral medium.

Free-living and lumenicolous forms :

Fixation : The most commonly used fixative for free-living and intestinal protozoa is Schaudinn's fluid. Before fixation one small drop of sample is to be poured on the middle of the slide by means of micropipette. Protozoa to be fixed should be observed under microscope. When the sample becomes semidried and protozoa becomes almost motionless with its normal shape then one or two drops of Schaudinn's fluid are to be gently dropped on the sample and kept for 5 to 15 minutes. After fixation it is necessary to wash the fixative with 70 per cent alcohol to remove all traces of mercuric chloride present in the fixative.

The other fixatives commonly used are, Carnoy's fluid, Carnoy's acetic alcohol, Bouin's fluid and Zenker's fluid. Blood-smears are often fixed with acetone free absolute methyl alcohol. Carnoy's fluid is good for nuclear study.

Staining and differentiation : Staining is done in accordance with the fixatives used and organellae to be studied. For

example, for ciliary lines silver nitrate solution or potargal stain is used, and for nucleus, Feulgen nuclear reaction is recommended.

Heidenhain's iron-haematoxylin is the most suitable and widely used stain for protozoan studies. It requires a mordant, ammonia-ferric sulphate (iron alum) and a dye, haematoxylin. To use this stain the specimen/smear is brought to water through descending series of alcohol (from 70 per cent to 30 per cent then water), kept in 3 per cent iron alum for three hours or more, rinsed in distilled water and then dipped in 0.5 per cent Heidenhain's iron-haematoxylin for 3 hours; it is then rinsed in distilled water and differentiated (destained) in 1 per cent iron alum under microscope until the proper intensity of the colour is reached; then, it is kept under running water for 5 minutes or so and gradually dehydrated.

Dehydration and mounting : Dehydration is done through ascending series of alcohol (30%-70%-90%-absolute alcohol). The slide is then cleared with xylol and mounted in a neutral medium such as DPX or Canada Balsam. Very thin mounting medium and thin coverslips are preferred for specimens to be observed under oil immersion lens.

For detail staining procedure with various stains Kudo's (1977) Protozoology may be referred to.

Labelling

The slides should be properly labelled with pertinent information indicating the name of species, host, place and date of collecting, date of preparation, name of the collector, site of infection and number of examples.

Histozoic and coelozoic forms :

- i. Usually thin blood films are drawn on scrupulously cleaned slides for blood-inhabiting protozoa. It is dried rapidly by waving in the air. The air-dried films are fixed in Acetone-free (absolute) methyl alcohol (5 min) and allowed to dry. Giemsa's stain is used for staining blood films. The stain is diluted upto 1 drop in 1 ml of 7.0-7.2 pH distilled water or buffer. The stain is poured on slides with smear side up, placed on a staining rack and left for 45 min. It is then washed with neutral distilled water or buffer solution and dried. Unmounted slides are wrapped in wrapping paper and preserved and if necessary, mounted in neutral mounting medium.
- ii. Suspected organ-imprint-smears are made pressing the cut surface of the dissected organs on to a clean and grease free slide. After drying in air, the smears are fixed and stained as described for blood films above.
- iii. Histological preparations for tissue section are made by fixing suspected organs in Carnoy's or Bouin's fixatives embedding in paraffin, making microtome sections, stretching pieces of sections on slides over a hot plate processing through xylol, absolute alcohol down to water, staining with Haematoxylin, dehydration, clearing and mounting to be done in the usual way. For a detailed standard histological procedure see Pearse, 1960, Histochemistry, 2nd edition, London.

To preserve as culture :**Cultivation of freshwater protozoa :**

For the preparation of culture sterilisation is a must. For successful culture of freshwater protozoa pure line culture is important. The desired species is isolated from freshwater sample by adding 25 ml of a nutrient solution (1% protose peptone and 500 ml of streptomycin per ml into 5 ml of freshwater sample). If the species survives the antibiotic action of streptomycin, it can be isolated after the second and before the fourth day so that appreciable growth of bacteria may not occur in that water. After isolation, it is cultured in some suitable culture medium. Successive subcultures are made to ensure continuity before the original culture starts deteriorating.

- i. *Flagellates* : Wheat infusion is used by autoclaving 32-40 grains of whole wheat in 25 ml of tap water at 15 lb pressure for about 2 hrs. The stock solution is prepared by adding 50 ml of distilled water to it. 5-7% concentration of the stock solution is made for culture.

Soil-water culture is also used by heating 2 wheat grains under 4 cm column of dry and powdered soil with adequate water in a test tube for about 3 hrs. The isolated specimens/species are inoculated and left in the dark for the colourless forms or kept in sun-light during summer for the green forms. In winter, a large 500 W lamp is used with a water screen in between to supplement the natural light.

Inorganic media viz., Lwoff and Lwoff medium (Lwoff, M and Lwoff, A. 1929. *C. R. Soc. Biol.*,

102 : 569) (Tryptone or Peptone - 2 gm, KH_2PO_4 - 0.25 gm, MgSO_4 - 0.25 gm, KCl - 0.25 gm, FeCl_3 - trace, Sodium acetate - 2 gm, distilled water - 1 litre) and Loeffler's medium (Loefer, J. B. 1934. *Science*, New York, 80 : 206) (KNO_3 - 0.5 gm, Tryptone - 2.5 gm, KH_2PO_4 - 0.5 gm, MgSO_4 - 0.1 gm, NaCl - 0.1 gm, Sodium acetate - 2.5 gm, distilled water - 1 litre) are also employed for the culture of flagellates.

ii. *Rhizopods* : Rice agar plates are prepared by embedding two rice grains well apart in a thin layer of non-nutrient agar. Freshwater amoeba is inoculated along with 4 ml of freshwater. The culture solution (NaCl - 1.20 gm, KCl - 0.03 gm, CaCl_2 - 0.04 gm, NaHCO_3 - 0.02 gm, phosphate buffer solution, pH 6.9 - 7.0, 50 ml, and distilled water - 1000 ml) is added after diluting it to 1 : 10. The rhizopod grown culture is transferred to a rice agar bowl (prepared with 70% non-nutrient agar, embedding 5 rice grains and adding 300 ml of the above stated culture solution) and maintained at 19° - 22° C.

iii. *Ciliates* : Pure culture of ciliates may be attempted as follows :

In Carter's culture solution comprising of KCl - 0.5 gm, NaCl 2.0 gm, MgCl_2 - 0.2 gm, CaCl_2 - 0.5 gm, and buffer solution (KH_2PO_4 - 0.1 gm, KOH - 0.01 gm, pH - 6.8 - 7.0) with half boiled rice grains (Carter, L. 1957. *J. exp. Biol.* Cambridge, 34 : 71).

In Hay infusion, prepared by boiling 1.5 - 1.7 gm of

hay for about 30 min. in 200 ml of tap-water. Maintain pH 7.0 - 7.2 by adding CaCO₃.

Cultivation of soil Protozoa

- i. Suitable strains of bacteria are selected to cultivate the soil forms. Six "bacterial rings" (2.5 cm diameter) are prepared of 2-5 days old culture on a non-nutrient agar plate. Small fragments of soil are inoculated in each 'bacterial ring' and incubated at 21 - 22°C for one to two weeks. Sterile tap-water or 0.5% NaCl solution is used to keep the soil moist.
- ii. Soil-extract agar is prepared for the culture of soil flagellates. 200 gms of soil and 500 ml of tap water are boiled gently for 1 hr. The solution is filtered, 1.5% agar extract is made and sterilised at 15 lb pressure. It is then cultured as described above.
- iii. Chopped hay infusion (50 gm in 100 ml) is used to make 1.5% agar extract and cultured as above.

Cultivation of parasitic Protozoa

For the cultivation of parasitic protozoa, suitable cultures and media are used *viz.*, cell and tissue cultures, chicken embryo as well as defined, semidefined and complex media.

A few widely used media for lumenicolous, blood-and tissue-inhabiting forms are mentioned below :

- i. *In vitro* culture of some stages *viz.*, Crithidia and Blastocrithidia, of the monogenetic trypanosomes can be possible in a simple medium of peptone, glucose, sodium chloride and water.

- ii. The most classical medium for the culture of digentic tryposomes in NNN medium.
- iii. Intra-erythrocytic stages of malarial parasites can be cultured in host erythrocytes suspension (Trager, W. 1947 *J. Parasit.*, 33:345).
- iv. For axenic culture and also termite flagellates, TYM (trypticase, yeast, maltase) TTY (Tryptose, trypticase, yeast extract) are used.
- v. *Balantidium* can be grown in saline serum solution.
- vi. Microsporidians can be cultivated in roller tube in a medium of horse serum (50%), balanced salt solution (40%) and beef embryo extract (10%).

However, for details of the different media employed in microbiological research for specific purposes the book on "Methods of cultivating parasites *in vitro*" edited by Taylor and Baker (1978) may be referred to.

Mesozoa

The mesozoans are minute worm-like solid organisms mostly ranging between 3 mm and 7 mm in length. These organisms resemble colonial protozoans and possess two cell layers which are, however, not comparable with the ectoderm and endoderm of metazoans. These animals inhabit the nephridia of octopus and squids and sometimes parasitise the tissues and cavities of flatworms, nemertines, brittle stars and clams (bivalves).

Collection

Mesozoans are monoxenous parasites of invertebrates. A freshly killed host is placed on the dissecting tray with the help of needles. It is dissected dorsally from the posterior portion. The suspected organ is cut out of the host body in a watch glass or cavity block. The renal organs (nephridia) are punctured and smeared on clear slides. The cut surfaces of the suspected tissues are also smeared for histozoic forms. The smears are quickly air-dried, fixed in methyl alcohol, and stained with Giemsa's stain.

Preservation

If the living specimens are large enough and easily visible, they can be best handled by special methods. The specimen is placed in normal saline on slide and watched under a microscope with a dropper of Schaudinn's fixative ready at hand. When the parasite stretches out, fixative is quickly squirted on it. A cover-slip is pressed on the specimen lightly with a needle just to prevent it from curling. Enough fixative is maintained for 5-10 minutes. The specimen is flushed on a cavity block with fixative or 70% alcohol and brought down to distilled water through various grades of alcohol successively, stained in Heidenhain's iron-haematoxylin, Ehrlich's acid-haematoxylin or Harris' haematoxylin etc., differentiated, dehydrated and put in xylol for clearing the specimens as for Protozoa. Then sufficient Canada balsam (mountant) is put on the middle of a clean slide and one specimen from the cavity block is brought by means of a fine forceps or brush and dipped in the mountant which must cover the whole specimen. It is then mounted with thin and clean coverslip and labelled as for protozoa.

Some Marine Invertebrates

The marine organisms can broadly be classified on the basis of their size into macrofauna, microfauna and meiofauna. Large sized animals which can easily be seen by the naked eye such as fishes, crabs, sea stars, snails, etc., constitute the macrofauna; those measuring a few millimetres such as copepods, chaetognaths, larvae, etc., are known as microfauna; and very small organisms which pass through 1 mm seive but are retained by 50 μ m seive constitute the meiofauna. They can also be classified on the basis of their habits into the benthos, nekton and plankton. The sedentary, burrowing and crawling organisms which are found at the bottom of the sea are called benthos, for example sponges, barnacles, polychaetes, crabs, starfish, etc.; those which actively swim in the open sea are known as nekton, e.g. fishes, squids, sea snakes, marine mammals, etc., and small microscopic organisms with feeble swimming power, drifting passively in the sea are known as plankton, e.g. copepods, chaetognaths, larvae, etc. This part deals with only some of the common marine invertebrates.

Collection

The method of collecting and preservation depends on various factors such as nature of the bottom, size and group of animals concerned, depth, etc.

Benthos : The equipments used vary with the texture of the sea bottom. In the intertidal region, simple equipments like handnets are used. For organisms attached to rocks and living in

their crevices and burrows, hammer, chisel, scalpel or forceps are used. Organisms inhabiting sand and mud are collected by transferring the substratum into a sieve with the help of a shovel, and subsequent washing. For the collection of meiofauna, the substratum up to 30 cm depth is dug and transferred to a wide polythene basin. It is kept for a day or two without disturbing, when the organisms come to upper layers. Samples from this superficial stratum are taken for study. For quantitative assessment, a 30 cm long corer of required cross section is used.

Fauna inhabiting deeper waters is collected by various types of dredges and grabs. A dredge, in general, consists of an iron frame of triangular or rectangular shape, carrying a bag like fish-net of cotton or wire mesh. When the dredge is dragged along the bottom with the help of a wire rope from a mechanised vessel, the crawling and shallow burrowing organisms are scooped into the wire-mesh where they are washed free of the substratum. The size of the frame and mesh are determined by the size of the organisms to be collected, the depth of operation and the vessel. It is mainly used for quantitative sampling of the macrofauna.

A grab is used for quantitative sampling of the benthos in shallow waters. Peterson's grab is the simplest type and forms the basis for all later modifications. It consists of a pair of heavy metal jaws held open during descent. On striking the bottom the jaws penetrate the soft substratum. Upon hauling up, the jaw scoop the substratum along with the inhabiting organisms and snap-shut. As it digs a constant surface area, depending upon the size of the jaws, the sample can be used for quantitative studies.

A coring device consisting of a long tube that is driven deep into the substratum is used for collecting microscopic organisms such as foraminifera and bacteria.

The samples thus collected are sieved, washed in clean water and the organisms transferred to containers of suitable sizes.

Nekton : For commercially important fishes, various types of nets, traps, trawls, hooks and harpoons are used. For scientific research, a beam trawl is generally used, which is similar to a dredge, consisting of a bag like fish-net the mouth of which is kept open by a beam. Unlike the dredge, the beam trawl does not dig into the bottom. Only the crawling organisms and organisms swimming near the bottom are collected into the the net.

For mid-water trawling an otter trawl whose mouth is kept open during operation by a pair of otter boards is used. Organisms swimming in the mid-waters are caught in the net.

Plankton : For collecting planktonic organisms there are various types of plankton nets and recorders. A simple plankton net consists of a filtering cone of bolting cloth fitted to a metallic ring at the wide end and a small collecting jar at the narrow end. When the net is towed the planktonic organisms are sieved by the filtering cone and collected into the jar. Several modifications in the above are made according to need such as to increasing the filtering capacity, to avoid back wash, to record the amount of water filtered or to close the net at required depth or time.

Preservation

The process of preservation consists of three stages,

namely, narcotisation, killing and fixation, and preservation.

Narcotisation : The organisms are first narcotised to prevent shrinking, distortion in shape, etc. Different substances and methods are used for narcotisation of various organisms.

- i) **Menthol/Magnesium chloride** : The animals are kept in a clean basin or petri dish with sea water and small quantity of menthol or magnesium chloride is sprinkled over the water and covered with a lid. Within 4-6 hours the animals are narcotised.
- ii) **Alcohol/Chloral hydrate** : 70% ethyl alcohol or 1% solution of chloral hydrate is added drop by drop at frequent intervals to sea water in which the animals are kept. The organisms are thus narcotised in a relaxed condition.

Killing and fixation

The narcotised animals are transferred to different killing and fixing agents such as 4% neutral formaldehyde solution, 90% ethyl alcohol or 10% solution of hot corrosive sublimate for periods varying from a few minutes to a few hours depending on the size of the animal to be killed and fixed.

Preservation

After fixation the specimens are preserved either in neutral formaldehyde solution or in ethyl alcohol.

- i) ***Neutral formalin*** : 40% Formaldehyde solution is neutralised with hexane or calcium carbonate, and decolourised with animal charcol. The supernatant is

decanted into a clean container diluted 1:9 with sea water and labelled as neutral 4% solution of formaldehyde.

The neutral formalin is a good killing and preserving medium for many groups of soft-bodied animals as it does not shrink the tissues and does not require the organisms to be passed through different grades of strength as is required in alcohol. However, it destroys the calcareous structures of sponges, holothurians, etc., and softens the tissue of certain animals rendering the specimens useless after prolonged preservation.

- ii) *Alcohol* : Ethyl alcohol is by far the best known killing and preserving medium for almost all marine organisms. The narcotised animals are passed through different grades of ethyl alcohol from 30% to 90% and finally stored in 90% alcohol, after one or two changes. The containers in which these organisms are stored should be air tight and the preservative should be checked and replaced at intervals.

Specific preservation methods

Porifera

Sponges are washed in clean sea water, fixed in 70-90% ethyl alcohol, and preserved either in 90% alcohol or in dried condition. They are stored in air tight containers in a dry place. Formalin should not be used at any stage.

Coelenterata

- i) Hydroids are narcotised in menthol, killed and fixed in

- corrosive sublimate and preserved in 10% formalin. (4% neutral formaldehyde solution).
- ii) Hydromedusae are narcotised slowly by adding 1% solution of formaldehyde drop by drop, and fixed and preserved in 4% neutral formaldehyde solution.
 - iii) Siphonophores are narcotised in menthol, and fixed and preserved in 4% formaldehyde solution. For killing colonies in expanded condition, a mixture of corrosive sublimate and copper sulphate can be used. A few drops of nitric acid are added to prevent formation of precipitate. For hardening the tissues, Fleming solution (Chromic acid 1% - 15 parts, Oxalic acid 2% - 4 parts, Glacial acetic acid - 1 part) is poured before preserving in formalin.
 - iv) Scyphomedusae are killed and fixed in formalin. To make the jelly tough and more pliable a 5% solution of chromic acid is used. These are finally preserved in 4% formaldehyde solution.
 - v) Sea-anemones are narcotised with menthol or 1% formaldehyde solution, and fixed and preserved in 4% formaldehyde solution.
 - vi) Corals are narcotised with menthol, killed and fixed in hot corrosive sublimate and preserved in 90% ethyl alcohol. They can also be killed in formalin and the skeletons cleaned with liquid bleach, and preserved in dry state, free from dust.

Ctenophora

Ctenophores are killed in formalin, washed in fresh water,

gradually dehydrated through 30%, 50%, and 70% ethyl alcohol.

Polychaeta (Annelida)

Polychaetes are narcotised by slow addition of 70% ethyl alcohol to the sea water containing the worms or by sprinkling a few mg. of menthol or magnesium chloride over the sea-water. After the specimens are stretched, these are fixed and preserved in 90% ethyl alcohol. Addition of one or two drops of glacial acetic acid just before the worms get narcotised, induces eversion of the proboscis, particularly in nereids.

Sipuncula and Phoronida

These organisms are narcotised by sprinkling a small quantity of menthol or by adding a few drops of 70% ethyl alcohol to the sea water containing the worms or by transferring the worms to 7% solution of magnesium chloride prepared in distilled water. Next the worms are left in the relaxing medium for 4-12 hours until these do not respond to touch. The worms are then transferred to 4% formaldehyde solution for fixation and finally to 70% ethyl alcohol for permanent preservation.

Echiura

In addition to narcotisation of these organisms by the above mentioned procedure, these worms can also be narcotised by immersing in a 1% solution of propylene phenoxetol.

Brachiopoda

These organisms are narcotised slowly by adding 70% alcohol and preserved in 90% alcohol. For proper preservation

of internal organs, a piece of wood or a small nail may be introduced between the valves to keep them open.

Bryozoa

These organisms are killed and preserved in 4% formaldehyde solution or 90% ethyl alcohol or are stored dry after killing in formalin. A few colonies may be passed through graded alcohol and xylene and mounted in DPX.

Chaetognatha

These organisms are killed in 1% formaldehyde solution and preserved in 4% formaldehyde solution. Alcohol should not be used.

Gastrotricha, Kinorhyncha, Tardigrada, Nemartina and Rotifera

The organisms are fixed and preserved in 5-10% neutral formaldehyde solution, containing 2% glycerine. Whole mounts of the specimens are prepared in glycerine, covered with a cover slip, and ringed with synthetic cement.

Echinodermata

The specimens other than echinoids are relaxed in fresh water and simultaneously narcotised with menthol or magnesium chloride or by slow addition of 70% ethyl alcohol. These are then killed and fixed as well as preserved in 90% ethyl alcohol, after two or three changes. The coelomic fluid of regular echinoids should be drained out by piercing the peristomial membrane and fixed in 90% ethyl alcohol. Irregular echinoids may be directly fixed in 90% alcohol. Formalin can be used as a fixing agent but not for preservation. The

formalin-fixed specimens should be dried and stored in air tight containers. Holothurians are killed and preserved only in 90% ethyl alcohol, and formalin should not be used at any stage.

Meiofauna

The meiofaunal sample is transferred to a beaker containing 6% magnesium chloride as narcotiser. The supernatant is decanted and sieved. The organisms are fixed and preserved in 4% neutral formaldehyde solution or 70% ethyl alcohol.

Labelling

After preservation the specimens should be properly labelled. The label should indicate the locality (name of place, district and state, station number, latitude and longitude, and depth), date of collection, name of collector, name of the vessel and cruise number, etc. Good quality paper and water proof Indian Ink are to be used for writing labels.

Packing and storage

The specimens should be stored in tubes, jars or drums, depending on the size of the specimen. Dried specimens are kept in air tight containers, with insect repellants, and stored in a dry place, devoid of moisture and dust. For specimens preserved in alcohol, the preservative should be checked from time to time and replaced as and when necessary. In case more than one specimen is stored in the same container, the specimens, should have their labels tied on to them, then wrapped in cheese cloth and stored.

Platyhelminthes

Phylum Platyhelminthes includes animals usually known as flatworms. Platyhelminths are bilaterally symmetrical and dorsoventrally flattened worms. Body shape is generally worm-like but vary from moderately elongated flattened shape to long flat ribbon and leaf-like. They are small to moderate in size varying from microscopic to extremely elongated forms, measuring up to 10-15 metres. Majority of flatworms are white or colourless. Some derive colour from the ingested food. The free living forms are brown, grey, black or brilliantly coloured. The anterior end of the body is differentiated into head which bears attachment organs in the form of suckers, hooks adhesive glands, etc. The ventral surface bears the oral and genital openings. The genital pore is well marked in Turbellaria than in parasitic helminths. Body is covered with a cellular syncytial, single layered, ciliated epidermis in free living forms, while in parasitic forms it is replaced by cuticle. They have no exo-or endoskeleton and the body is generally soft. Hard parts comprise cuticle, spines, hooks, etc. A true coelom is lacking and body space between different organs is filled with parenchyma. Digestive system is totally absent in cestodes and Acoela but in all other flat worms it consists of mouth, pharynx and a blind intestine. However, in some forms, anus may be present and pharynx absent. Respiratory and circulatory systems are absent. Excretory system consists of paired protonephridia, with flame cells or bulbs. Nervous system is primitive. They are mostly hermaphroditic, with highly

developed reproductive system. Life cycle is complicated involving one or more hosts, in parasitic forms. The flatworms are either free living or ecto-or-endoparasites. As parasites, they inhabit all organs-systems of the host. The most preferred habitat for endoparasites is the gut but they may also be found in other organs like lungs, kidney, heart, liver, gallbladder, pancreas, eye, brain, body muscles, etc. The ectoparasites normally parasitise the gills of aquatic animals, buccal cavity, urinary bladder, etc. Non-parasitic forms e.g. *Turbellaria* live in slow flowing streams, under rocks and stones, in fresh and marine waters, damp and moist soils, etc.; some of them are commensals.

Phylum Platyhelminthes is divided into four classes: *Turbellaria*, *Monogenea*, *Trematoda*, *Cestoidea*.

Turbellaria : Turbellaria are mostly free living flatworms but some are ecto-parasites or endocommensals or parasitic. Body is unsegmented, covered with a cellular or syncytial epidermis which is usually partly ciliated. There are no hooks or spines but are provided with two types of adhesive organs i.e. glandula epidermal adhesive organ and glandula muscular adhesive organ. Digestive system consists of mouth, pharynx and intestine except in Acoela in which intestine is absent. Excretory system consists of protonephridia, having terminal flame bulbs. Sense organs consists of tangoreceptors and chemoreceptors. They are hermaphroditic or dioecious, with very few exceptions. Reproduction is sexual, asexual or by regeneration. Life cycle is simple.

Monogenea : They are external parasites on the skin and gills of aquatic vertebrates, primarily fish. Some occur in the

mouth and urinary bladder of amphibians and reptiles. Adhesive organs are known as haptors; prohaptor at the anterior end of the body and opisthohaptor at the posterior end. The opisthohaptor shows great variation in structure, some having a single sucker and others a number of them; the suckers being either naked or armed with hooks and spines or in being modified as grasping clamps with a supporting skeleton. The nature of haptor is of taxonomic importance. They are hermaphroditic. The life cycle is direct. The egg hatches into an oncomiracidium which is ciliated and bears numerous hooks so that the larva is well adapted both for swimming and for attachment.

Trematoda : Adults are endoparasitic, occurring in all classes of vertebrates, and, in a few cases, in invertebrates. Usually there is a muscular oral sucker surrounding the mouth at the anterior end of the body, and a sucker on the ventral surface of the body. The digestive tract is inverted Y - shaped, usually without an anus. Excretory pore is single, situated at the posterior end. Hermaphroditic except Schistosomatidae which are dioecious. Life cycle is indirect, with many larval stages and one or more intermediate hosts.

Cestoidea : Cestodes are commonly known as tapeworms which are parasitic in the intestine, stomach, bile ducts of mammals, intestine of all other classes of vertebrates, and in coelom of some fishes and freshwater oligochaetes. Normally the body is divided into a number of segments (proglottids) and the worms are known as polyzoic, but in some primitive forms the body is unsegmented and these are known as monozoic. The digestive system is totally lacking. Attachment organs are in the form of suckers, with or without rostellum on the head or

scolex; absent in Cestodaria. Scolex is followed by neck which is the zone of proliferation; the strobila or the chain of proglottids originate by budding from neck. Proglottids immediately behind the neck are indistinct, being underdeveloped, and the internal organs are not differentiated. Each proglottid is complete with the gonads, and a single strobila contains immature, mature and gravid proglottids. They are normally monoecious and protandrous. Genital pores are located laterally or ventrally. Life cycle is indirect involving alternate hosts. In a few cases it is direct also.

Collection and preservation of all helminths for study are to be made, keeping in view that there is no distortion in morphological character due to contraction of body parts. As far as practicable the specimens should be collected in living or fresh condition and examined before preservation as some characters are obliterated due to postmortem changes. The collection and preservation methods for parasitic helminths are the same except some minor variations but the free living Turbellaria need separate treatment. The collection and preservation methods are dealt with separately for free living and parasitic forms.

Free-living forms (Turbellarians)

Collection

They mostly live in water, under stones in ponds and streams, on aquatic weeds, in damp soil, under stones, twigs or among vegetation. The collecting of turbellarians is done by hand picking or by a water net.

Preservation

After collecting, the specimens are kept in petridish with

some water. A few crystals of menthol, chloral hydrate or camphor are sprinkled over the water to relax the specimens. The relaxation can also be done by keeping the specimens in 1% nitric acid solution for a few seconds. If the specimens are small, fixation is best achieved by pressing them between two slides, tied with thread and left in the fixative for 24 hours. If necessary, the specimens may be bleached with Mayer's chlorine solution to make it more receptive to stains and to remove heavy pigmentation in some turbellarians. It is better to starve bigger turbellarians for a few days before fixation. After the specimens have relaxed, the water is drained off and the fixative is poured gently over the specimens and left for 24 hours. Then the specimens are washed and stored in 70 - 90% ethyl alcohol.

The following fixatives may be used :

Golden's fixative : Mercuric chloride 5 g, glacial acetic acid 1 ml, 80% nitric acid 4 ml, 90 alcohol 15 ml, distilled water 220 ml. This mixture is allowed to stand for three days and filtered.

F.A.A. : Absolute alcohol 90 parts; glacial acetic acid 5 parts; 40% formaldehyde 5 parts. This solution is poured hot after the specimen is kept to freezing temperature.

3 - 5% formalin solution : The specimens should be kept overnight.

Nitric acid-corrosive sublimate solution : Nitric acid 3 parts; saturated solution of Mercuric chloride 3 parts; water 4 parts. Acid should be added to other two solutions not vice-versa. After dipping the specimens for two or three minutes,

the specimens should be washed thoroughly in running water or 70% alcohol.

The bleaching agent or Mayer's chlorine solution is prepared by pouring concentrated hydrochloric acid over a few crystals of Potassium chlorate kept in a petridish. As soon as the fumes of chlorine gas come out, 25 - 30 ml of 70% alcohol is poured in the petridish. The mixture is used for bleaching the specimens. Usually the specimens are left in the solution for sometime. The bleaching is to be done within 2 hours of collecting.

The staining procedure for study of the specimens is given elsewhere in the article.

Parasitic Helminths (Monogenea, Trematoda, Cestoda):

Collection

Living or freshly killed hosts should be examined for collection of parasitic helminths. The animal should be autopsied as soon as possible after the death of the host. The delay may cause migration of parasites from their normal location or their disintegration in the dead host. If delay in examination is likely to occur the host should be preserved in refrigerator to check the postmortem changes. The method of autopsy of all the hosts is the same.

External examination : When examining the fish the entire outer surface must be searched carefully, specially the oral region, the gills, the opercula and the fins. On gills and often on fins the Monogenea may be present. On the body and

fins there might be encysted metacercaria of digenetic trematodes.

Internal Examination : After the external examination is over the animal is kept in an enamel tray containing saline water. A long incision is made from anus to urinogenital opening on the mid-ventral surface. Before removing the viscera the body cavity is examined for any parasites or cysts. Now the internal organs are removed, one at a time and placed separately in dishes containing saline solution. Each organ is cut open and agitated in saline solution to dislodge the parasite in it. The parasites can be seen showing movements and they are picked up with the help of a fine dropper or brush. Many parasites do not dislodge themselves easily and the organ may be examined thoroughly by decanting the fluid several times. This process has to be followed while examining the gut. If the intestine is large it can be cut into pieces and each piece examined separately. All other organs such as heart with aortic arches, liver, gall bladder, bile duct, pancreatic duct, lungs, kidneys, urinary bladder, hepatic and mesenteric veins, and other organs should likewise be examined and parasites collected. Some parasites can be seen by naked eyes and other by the help of a binocular. Many cysts may be visible on the body surface, muscles, body cavity or peritoneal membranes and can be collected easily from it by piercing the cyst by a fine needle. But, at times, the cysts are embedded in body muscles, and the collection is done by using some digestive fluid for dissolving the muscles. Since the worms are mostly light coloured it is advantageous to keep the dish over a black or dark background for examination, with sufficient light.

For recovering small Monogenea, Mizelle (1938) recommends freezing fish gills for 6 to 24 hours in a jar. Then the jar is filled with tap water and shaken vigorously. The liquid with freed parasites are poured in dishes, diluted and examined. For recovering *Gyrodactylus* it is recommended to place the fish in a small dish containing 1 : 4000 solution of formalin. After few minutes the worms fall to the bottom of the dish.

It is always advisable to study the specimen in living condition and make note of the condition of different structures. This is essential as many structures become obliterated after fixation. In trematode the excretory system is best seen in living condition and should be studied and a rough diagram made as it is of taxonomic importance. If need be vital stains (neutral red 0.1% or methylin blue 0.1% solution) should be used. Similarly the collar spines in echinostomes should be counted in live condition, as during processing they are likely to fall down. Digestive system and genital pores are also more prominent in live condition than after fixation. This is all the more essential in case of cercaria.

For collecting, study and preservation of larval trematodes (sporocyst, redia and cercaria) the snails are brought to the laboratory and isolated individually in glass jars. The jar is examined against transmitted light to see if any cercariae have been discharged. The medium of the snail is changed daily. Once the cercariae start coming out they are studied in fresh condition using vital stains. For fixation and permanent mounting the usual procedures are followed. The sporocyst and redia are recovered by crushing the snail and examining its

hepatopancreas. Rest of the procedure is as for cercaria. It is necessary to study the excretory system and number of flame cells in living condition using vital stains (0.1% neutral red or 0.1% methylin blue) as these structures are obliterated on fixation.

Preservation

Fixation : In a broad sense, fixation comprises arresting the life processes, preserving and hardening the animal as nearly as possible in its natural condition. This is achieved through the use of certain chemicals, the fixatives, and is the most important step in the preparation of the material for study.

The worms are thoroughly washed in saline solution to render them free of debris and mucus. After the worms are cleaned it is advantageous to wash them in distilled water for some eggs remain in the medium which could be used for other studies. Trematodes and cestodes give considerable trouble by contracting and thickening upon fixation. To avoid this in most cases it is preferred to place them between two slides or under coverslip, depending upon the thickness of the worm, tied with thread and kept in the appropriate fixative. This process is liable to distort the shape of the parasite and may disturb the normal position of the internal organs. In case of smaller specimens the best method is to shake them vigorously in hot water or 4% hot formalin. The specimens killed in hot water should be placed in the fixative. The specimens killed in hot formalin need not be placed in any other fixative. If the specimens are flattened under the pressure of cover slip or slide it is advisable to fix some unpressed specimens which may be used for cutting sections to study the internal anatomy, should

some confusion in the placement of internal structures arise. Any of the following fixatives could be used:

Hot Bouin's fluid : Hot 10% Formalin : A-F-A : After fixation, the specimens are thoroughly washed and preserved in 70% ethyl alcohol. The specimens fixed in Bouin's fluid should be washed in 70% alcohol till the yellow colour disappears. The process can be accelerated by adding a few drops of ammonium hydroxide or Lithium carbonate to the alcohol. The fixation is accomplished in 3-24 hours. If the material is to be stored for long period it is advisable to add 5% glycerine to the 70% alcohol. All the vials containing the specimens must have label containing all the data. The platyhelminths are best stored as permanent mounts. For study it is essential to stain the specimens and mounts prepared. Many stains are used according to need.

Staining : When treating specimens with alcohol or other reagents, the liquid should be 4 times the bulk of parasites. Transfer of specimen from one liquid to another is made by pouring off the first liquid, after which the second liquid is added immediately. If the specimens are very small or delicate, the liquid is withdrawn with the help of a fine dropper rather than pouring the liquid. As a precaution, the first liquid should be poured in a petridish so that if any specimen has inadvertently been drained off it could be recovered.

In choice of stain the prime consideration is its ability to differentiate clearly the anatomy of the specimen. It should (1) be very dependable and easy to use, (2) follow the common fixing agents well, (3) retain optimum staining properties for many years, and (4) not form precipitates in the material. Most

commonly used stains are carmine and haematoxylin. Though both have advantages and disadvantages but serve the purpose well for whole mounts of helminths. Carmine stains should be used for alcohol-fixed material, and formalin fixed material should be stained in haematoxylin. Some of the commonly used stains are :

5% aqueous solution of Haemalum diluted to 0.5 - 1.0 %. The specimens are brought to water and then placed in the stain from 5 minutes to half an hour depending upon the size and thickness of the specimens, with several changes from tap water for differentiation to 0.1 - 1.0 % HCl and back to water till the requisite stain is taken by specimen and proper differentiation of organs achieved. This stain gives the best result if properly used and takes much less time than the other stains.

Schneider's aceto-carmine : 10 g carmine is heated in 100 ml of glacial acetic acid, cooled and filtered. The filtrate is used. The precipitate is dried and can be used for making aceto-alum-carmine. The specimen is placed in the stain which is diluted with distilled water, after bringing it to water and can be kept for 24 to 36 hours. Differentiation is done in acid water, 0.5% HCl.

Borax carmine : This stain is prepared by adding a 4% borax solution to 3% carmine solution and boiling it for 30 minutes. It is cooled and filtered and an equal amount of 70% ethyl alcohol is added. The specimen is stained from 10 to 30 minutes, and differentiated in acid alcohol.

Ehrlich's haematoxylin : The stain is prepared by dissolving haematoxylin (2g) in 25 ml absolute alcohol and adding 10 ml

glacial acetic acid, 100 ml distilled water and 10 g potassium sulphate in that order. The mixture is kept for ripening. After maturation the stain is of dark red colour.

The specimens are directly put in the stain from 10 minutes to one hour depending on the size and thickness of the specimen. It is put directly in tap water where it acquires blue colour. The differentiation is done in acid alcohol by repeatedly putting it in acid alcohol and water till the desired stage is reached.

Other stains like Delafield's haematoxylin, Heidenhain's haematoxylin or any other stain can be used depending on the requirement. The details can be found in any standard book on stain technology. The haptors of Monogenea are best stained by Gomori Trichrome stain.

Dehydration and mounting : After the specimens are stained they are dehydrated in graded alcohol. If the stain is aqueous the specimens are brought to 30% alcohol for half an hour giving at least 3 changes followed by 50%, 70%, 80% and 90% alcohols, giving at least 3-4 changes in 30-40 minutes. Then the specimens are transferred to absolute alcohol (100% alcohol), and cleared in xylol to see if any moisture is left. If the liquid does not turn milky the specimens are transferred to clove oil or Beach cedarwood oil for clearing. After the clearing is complete the specimens are once again put in xylol to remove the oil and mounted in canada balsam or any other suitable mountant. Care is taken that no air bubble remains. The slides are then dried and stored for study.

Labelling

The most important part in preparation of material for study

and storage is labelling of the material. The labels should be as complete as possible. The labelling should be done as soon as the material is collected and fixed. It should contain the scientific and common names of the host, locality from where the host was collected, location of the parasite within the host, fixing reagent, date of collection and name of the person who collected the specimens. The material without a label is useless for study. All the information about the collection should also be recorded in a note book giving the details and also information about the health condition of the host and any pathological lesions observed during the autopsy.

For non-parasitic forms labels should also include altitude of the place of collection, colour of specimen in living condition, nature of the soil, if terrestrial, or qualities of water, if aquatic, ecological condition of habitat, viz. nature of weeds, depth, etc.

Packing for despatch

It is advisable to send well-preserved, unstained, specimens in small vials, complete with labels, filled with preservative, and each vial wrapped separately in tissue paper. If the alcohol is used as preservative some space must be left unfilled for expansion of the liquid. It is better to wrap the inner end of the cork also with tissue paper so that any specimen sticking to it could be recovered. A small number of tubes should then be put in a bigger jar, with cotton padding and filled with the preservative. It should be ensured that the preservative must not leak out during transit. Plastic or metal containers, padded with thin layer of cotton and filled with additional preservative, are most ideal.

For quicker identification it is better to send stained and mounted material following standard procedures. Each slide should be wrapped in tissue paper and put vertically in slide box. Sufficient cotton padding or fine thermocol padding should be given in the slide box. The slide box then should be packed in cloth for despatch. A letter containing full data regarding the collection must accompany the material. Suitable instructions for handling by the postal department must be clearly printed/written on the parcel for despatch.

Nematoda, Acanthocephala and Gordiacea

Nematodes are one of the most important and highly diversified group of multicellular invertebrate animals which are popularly called as 'round worms'. They occur in all kinds of habitats. Most species are free living, predaceous or fungal feeders in the soil, salt and freshwater while others live as parasites of animals and plants. The collecting and preservation techniques of each ecological group of nematodes are somewhat different. The techniques regarding the collection and preservation of only some important groups of nematodes have been discussed, i.e., plant, soil and animal nematodes. The present paper recommends only those methods in which the recovery of nematodes is maximum and expensive equipments are not required.

Plant and soil nematodes

Plant parasitic nematodes are recognised as potential pests of our crops causing serious constraints to agricultural productivity. This economic importance has led to the emergence of nematology as an independent discipline and attracted a large number of scientists during the last 40 years. During the study of plant parasitic nematodes one will also encounter soil-inhabiting species of nematodes which are either free living, mycophagous or predaceous.

Soil and root sampling

Soil samples from around roots of host plants are collected with the help of shovel or any sharp cutting tool from a depth of 5-15 cm in the moist fields. If the field is semi-dry or dry, the sampling depth may be increased because most of the ectoparasites migrate downwards to avoid the dry conditions and high temperature. This is always better to collect 4-5 sub-samples (about 100 gms soil each) to form the bulk sample. The soil is collected in polythene bags and their open ends are properly closed with a rubber band, brought to the laboratory and stored in a fridge to avoid evaporation. All relevant data regarding host, locality, etc. are noted at the time of collection. Since a good number of the nematodes are endo-or semi-endo parasites, the plant roots are also brought to the laboratory in polythene bags. Some nematodes, e.g., *Aphelenchoides* spp., parasitising leaves, stems, buds and floral parts, may also be brought to the laboratory for examination.

Two most important parameters in sample transportation and storage are temperature (10°-13°C) and adequate moisture.

Processing of soil samples

Most of the methods for the extraction of fast moving ectoparasites, free-living forms and slow moving nematodes are based either on Bearmann funnel techniques or on its modification. Some of the important techniques are Bearmann funnel technique, Cobb decanting and sieving method; Oostenbrink elutriator methods (model II & III), Seinhorst elutriator, centrifugal flotation method etc. In the present write-up a combination of Cobb's (1916) sieving and decantation technique and Bearmann funnel technique has been discussed.

Approximately 500 gms of soil is placed in a bucket (A) of 15 lt. capacity filled to 1/3rd of its volume with water. The soil and water are thoroughly mixed by hand to make a homogenous suspension. Large pebbles and plant debris are removed and lumps are broken, if present, with finger tips. This bucket is left undisturbed for 20-30 seconds so as to allow the heavy particles of soil to settle down at the bottom, while the nematodes and fine soil particles remain suspended. This suspension is then filtered through a coarse sieve (2 mm pores) to get rid of debris and is collected in another bucket (B). The entire process is repeated twice or thrice.

The suspension finally obtained in bucket (B) is quite free from stones, leaves and other undesirable organic matter. The muddy suspension in bucket (B) is also made homogenous by hand and allowed to settle for 10-20 seconds, then passed through a sieve (if necessary, a set of two sieve) of 300 mesh with 53 μm pores. Most of the fine soil particles escape through sieve while the nematodes and larger soil particles are retained on the surface of sieve. The entire catch from the sieve is collected in a beaker of 250 ml.

The aliquot collected in the beaker is poured gently on moist double tissue paper placed on a small supporting coarse sieve with 2 mm pores. The air bubbles should not be allowed between the tissue papers because they will check the filtration of nematodes. The supporting coarse sieve is placed into a funnel which is half filled with water barely touching the surface of coarse-sieve. A piece of rubber tube of a suitable diameter is attached to the stem of funnel and is closed by a string or screw clip. Most of the nematodes pass through the tissue paper and settle at the bottom of funnel stem. The funnel

is placed in a stand and left undisturbed for 24 hours. After 24 hours, the nematodes are collected in a test tube by loosing the grip of the clip.

The disadvantage of this technique is the poor oxygenation in the rubber tube, attached to the stem of funnel, where the nematodes are collected. This problem has been overcome by replacing the funnel by a shallow petridish. The supporting coarse sieve with aliquot on the tissue paper is placed in a petridish filled with water touching the bottom of the coarse sieve.

Remarks

Thick and compact layer of clayey soil on the tissue paper checks the filtration of nematodes. To avoid this situation, the aliquot of one sample may be divided into two halves and extracted in two funnels/petridishes.

The slow moving nematodes pass very slowly through the filters (tissue paper). Hence, the extraction may be allowed for a longer period (more than 24 hours). Furthermore, the residue on the tissue paper may be examined under stereoscopic binocular for sluggish nematodes.

Isolation of cyst nematodes

Though the most widely used apparatus for extracting the cysts is Fenwick can (Fenwick, 1940), the manual picking of the cysts is found to be most appropriate technique for the maximum recovery of cysts. Water-soil-mixture, as described in earlier technique, is passed through a coarse sieve with 2 mm pore size to hold back all the large debris and pebbles etc. Now the bucket is refilled with water and immediately decanted over

20 and 60 mesh sieve, placed one above the other, keeping the former above. Most of the cysts pass through the 20 mesh sieve and collected over the 60 mesh sieve. The bucket is refilled with water and the process is repeated. Cysts collected with the debris are hand-picked with the help of a brush and stored in a refrigerator at about 4°C.

Besides the cysts in the soil, a large number of cysts are found half embedded in the roots. These cysts are teased out of the roots with the help of a needle under the stereoscopic binocular microscope. The roots must be washed gently before the cysts are teased out.

For the recovery of the intermediate developmental stages (late 2nd stage, 3rd stage and 4th stage juveniles, young females, etc.), the roots are stained in lactophenol-acid fuchsin for few minutes, destained by washing them in water and stored in lactophenol. The roots are taken out of lactophenol, as and when required and then dissected for the isolation of developmental stages.

Extraction of nematodes from plant material

The infested plant roots/shoots may also be kept in a refrigerator at 5°C - 10°C and examined as soon as possible.

The roots should be washed gently so that the maximum soil may be removed. The roots/shoots are chopped in small pieces with the help of scissors and a few small pieces are placed in an open petridish. The material is examined under stereoscopic binocular microscope and teased apart with stout needles. Nematodes released from plant tissue float out and can be collected with a handling needle in a separate cavity block.

For the soft roots, the chopped pieces may be placed in the blender, operated by electricity, for 1-2 min. Now the nematodes may be extracted by using the technique described above for the extraction of nematodes from the soil.

Killing and fixing

The suspension containing the nematodes is placed in a big test tube for 2-3 hours so that they could settle down at the bottom. Then most of the water is removed carefully from the test tube with the help of a dropper of suitable length. The nematodes settled at the test tube bottom should remain undisturbed.

Many fixatives have been recommended mainly for studying different characters. The present author has found good results by using F.a. as fixative which may be prepared as follows :

Formalin (40% formaldehyde)	10 ml
Glacial acetic acid	2-5 ml
Distilled water	100 ml

The fixative should be taken in a separate test tube at least twice the volume of the nematode suspension.

This method proved to be very effective because most of the nematodes are fixed in their characteristic postures. The nematodes can also be stored safely in this solution for a long period. The nematodes should be left in the fixative at least for 24 hours.

Mounting and sealing

For permanent mounts, the aluminium double-coverslip slides are preferred because the nematodes can be studied with

greater clarity from either side of the slide, specially to study the arrangement of labial papillae, overlap of oesophageal glands over intestine, position of oesophageal gland nuclei, reproductive system, the positions of deirids and phasmids, etc.

The aluminium slides are made of normal size of glass slides having a round hole in the centre of 20 mm diameter. The lateral edges of slides are turned upwards and inwards. A square coverslip of 22 mm is placed over the hole. Two pieces of cardboard are inserted on both the sides of the hole for the safety and labelling of the slide.

The nematodes are transferred from fixative to a solution of 5 parts of glycerine and 95 parts of 30% alcohol in a glass cavity. A fungicide (thymol, copper sulphate) may be added in small quantity to avoid growth of fungi. The container or glass cavity having the nematodes in the solution is placed in a desiccator for dehydration of nematodes at room temperature for 2-3 weeks. The coverglass over glass cavity should remain open slightly in the desiccator for slow dehydration of nematodes.

Now the nematodes are finally mounted in pure anhydrous glycerine. A small drop of anhydrous glycerine is put on the square coverslip placed on the hole of aluminium slide. The mounting drop should be of such a size that it just spreads to the edges of coverslip and not beyond. The nematodes of about same thickness may be selected under stereoscopic binocular microscope and transferred to the mounting drop of anhydrous glycerine with the help of hair needle. These may be arranged in the centre of the drop and put on the glass wool of suitable size to avoid the flattening of nematodes. Finally a clean round

coverslip is gently warmed over a small flame and placed over the drop.

The best sealing material is 'Zut' or 'Glyceel' which is applied on the outer edges of the round coverslip with the help of a brush. Ordinary nail polish is also used as sealing material.

Animal nematodes

1. Nematoda

The nematode parasites of vertebrate animals may be found anywhere in the body and can easily be recognised by their larger size and thread-like body. The host animal should be freshly killed. Place the animal in a pan or tray and cut through the body wall along the ventral line by incision from anterior to posterior end. First look for the parasites which may be free in the body cavity. Sometimes the animal may be infected by microfilariae or nematodes which may be encountered in the blood vessels. Then remove all the portions of digestive tract and place them separately in the petridishes filled with saline (Sodium chloride 7-8 gms and distilled water 1000 ml.). The organs like liver, lungs, heart, eyes, urinary bladder and reproductive tract should be removed and examined separately. These organs are examined by scrapping the tissues in separate petridishes containing saline. The dense organs like liver should be sliced, minced in saline and suspension examined under stereoscopic binocular microscope. The nematodes are picked up and stored temporarily in saline. In case there is a tumour in any part, a portion of surrounding tissues should also be examined.

Killing and fixing

The nematodes should not be left in saline for more than an hour because they swell and get damaged. Fixing may be done in any of the following liquids :

- i) Hot 70% alcohol (for preserving smoother forms only; put specimens for a few minutes to half an hour). The larger forms shrink in hot alcohol due to quick dehydration.
- ii) 3-5% hot formalin

The fixed material may be stored in a tube filled with fresh supply of 3-5% formalin or in 70% alcohol. All the necessary data (host, location, locality, date, etc.) may be written on a piece of paper with pencil and placed in the container having the nematodes.

Mounting

They are difficult to stain. The nematode parasites of animals are generally studied either in temporary and sealed mounts in glycerine, lectophenol or glycerine-jelly. However, most workers prefer temporary mounts. For clearing, the nematodes are transferred from fixative to glycerin alcohol (70% alcohol 90 parts & glycerine 10 parts). Cover with a piece of filter paper to exclude dust and allow evaporation until the nematodes are brought gradually into pure glycerine. This glycerine serves as a clearing agent.

2. Acanthocephala

The acanthocephalons are generally called thorny headed worms. They are elongate worms superficially resembling nematodes but differ in a number of characters (mainly in the

presence of proboscis and absence of intestine). The anterior end is provided with a retractile proboscis armed with hooks. In fact, their name is derived from the spiny proboscis by means of which they attach themselves firmly to the host's intestine. The adults are parasites in the intestine of vertebrates.

They are collected in the same way as nematodes. The following methods may be employed in handling them as in larger nematodes.

- i) Place living specimens in water until proboscis is fully averted and is not withdrawn when touched. This may require several hours and may be hastened by placing in the refrigerator.
- ii) Fix in Bouin's fluid for a few hours. The material may be stored indefinitely in this fluid.
- iii) Transfer directly to 70% alcohol and prick the body wall with fine needle. Change alcohol at intervals until it no longer turns yellow.
- iv) Stain in Harris' hematoxylin for several hours.
- v) Transfer to 30%, 50% and 70% alcohol in ascending order, for 15 minutes in each.
- vi) Destain in 70% acid-alcohol until very light pink in colour.
- vii) Wash in 70% alcohol and then place in 70% alkaline alcohol until blue in colour.
- viii) Dehydrate by placing successively in 80%, 95% and absolute alcohol for one to several hours in each. Keep dish tightly covered.
- ix) Wash hurriedly in xylol and mount in balsam.

Bouin's fluid

Picric acid, sat. ag. solution	75 parts
Formalin, commercial	25 parts
Acetic acid, glacial	5 parts

Harris' hematoxylin

Hematoxylin	2 gm
95% ethyl alcohol	50 ml
Aluminium ammonium sulphate	30 gm
Distilled water	500 ml
Mercuric oxide (red)	1 gm
Glacial acetic acid (optional)	5-20 ml

Dissolve alum in water and haematoxylin in alcohol. Bring alum solution to boil, remove from heat and add stain solution slowly with stirring. While still hot stir in mercuric oxide. When a deep purple colour appears, cool rapidly and filter. If acid hematoxylin is desired, add acetic acid.

The stain should be kept in refrigerator.

Acid alcohol

70% alcohol	99 parts
Concentrated hydrochloric acid	1-5 parts

Alkaline alcohol

70% alcohol	99 parts
1% Sodium bicarbonate	1 parts

3. Gordiacea

These are long worms like a thin wire. Hence, they are also called 'hairworms'. The young stages parasitise insects and occasionally other animals, mostly aquatic. Adults are free-living, usually in freshwater and rarely on land.

The 'hairworms' may be fixed in 3-5% formalin for 10-12 hours. They may be stored either in 3-5% formalin or in 70-90% alcohol.

Labelling

Labelling of specimens should be done immediately after collection. A thick, white, good quality of paper should be used for labelling. The following minimum information should be written neatly.

Exact locality, Block-Tehsil, District, State; if necessary, latitude, longitude, altitude, and depth, common and scientific name of the host; location in host body (name of the organ); date of collection; name of collector; if the specimens belong to new species, holotype (male or female), number of paratypes and their sexes.

Packing for despatch

The tubes containing specimens and the fixative may be wrapped separately in a paper or cloth and packed in a strong box of required size. The tube should be padded with cotton wool or soft crumpled paper. It is better to fill the tubes completely with the fixative so that any damage to the specimens be avoided. However, a slight space may be left in the tube, specially when it is filled with spirit, for its

expansion by heat. The corks of the tubes may be sealed with melted wax to prevent the evaporation of fixative or loosening of cork.

The metal or glass slides should also be padded properly at both ends (outside the cover slips) together with the help of rubber bands and packed in a strong box of suitable size. The space in the box should be filled up by cotton or glass wool.

Annelida

Annelids are true worms, with bodies composed of a linear series of similar segments marked externally by intersegmental grooves and internally by transverse septa extending from the body wall to the digestive tract. The body segments are sometimes secondarily subdivided externally into annuli (leeches and some sedentary polychaets). External segmentation may be indicated by the presence of bristles or setae (Polychaeta and Oligochaeta). The phylum includes three classes : Polychaeta (including the aberrant Myzostomida and Archiannelida), Oligochaeta and Hirudinoidea. Their forms and habits are briefly given below.

Form and habits

(i) *Polychaeta* (bristleworms) : These worms usually have a distinct head which bears eyes and a number of appendages. In majority of polychaetes, each segment following the head is provided with a pair of lateral bristle-bearing fleshy lobes called parapodia. They vary in length from less than 1 mm in some interstitial forms to over 3 m (some Eunicidae, Onuphidae). Although there are a few freshwater species, the bristleworms are widely distributed throughout the marine and estuarine environments, being abundant between tide-marks and shallow coastal waters (especially in mud and sand), but also occur at great depths. These are usually allocated to one of the two ecological groups - Errantia or Sedentaria. the errant polychaetes are free-living, either creeping among algae,

mud or sand or burrowing in the crevices of rocks, corals, stones, etc. (*Neries*, *Glycera*, *Lepidonotus*). Most of the sedentary polychaetes (*Sabella*, *Serpula*, *Spirorbis*, *Hydroides*) live in calcareous or fibrous tubes or burrows permanently located in or on the substratum. Some (*Amphinoma*, etc.) are commensal or ectoparasitic on hydroids, echinoderms and barnacles. Species of *Tomopteris* are entirely pelagic. The sexes are separate in most polychaetes, but hermaphroditic forms are also known (especially amongst Sabellidae and Serpulidae). Asexual reproduction is frequent in some polychaetes (Syllidae).

(ii) *Oligochaeta* (earthworms, potworms and freshwater ringed worms) : The oligochaetes lack parapodia, but the bristles or setae are implanted directly in the body wall. The head is devoid of appendages found in the polychaetes. On the basis of size and habitat, the oligochaetes are often divided into two convenient groups: Microdrili (small, mainly aquatic worms including the terrestrial family enchytraeidae - potworms) and Megadrili (larger, mostly terrestrial worms and their aquatic representatives). Some aquatic forms possess gills (*Branchiodrilus hortensis*, *Branchiura sowerbyi*). Terrestrial forms (earthworms) are found in all types of soils provided there is sufficient moisture and food. They occur in forests, grasslands, arable lands, gardens, orchards, plant nurseries and green houses. They have been found living in caves and axils of tree leaves. Organic materials like compost, manure, forest litter and humus, municipal dumps, soils wetted with effluents and kitchen drainage are highly attractive to some species (*Perionyx excavatus*, *Eisenia fetida*). Some earthworms are very hydrophilous (*Glyphidrilus tuberosus*, *Ocnerodrilus*

occidentalis) and occur near water bodies. A few species can live under snow on high mountains (*Dendrodrilus rubindus*). The Enchytraeidae occur in terrestrial, littoral and marine habitats. They are generally pale coloured worms with the body size usually varying between 10 and 20 mm long. They often occur in acidic soils containing high organic matter, coarse sand on sea shore, decayed sea weed, sewage beds and compost heaps. Oligochaetes are hermaphrodite. Parthenogenesis and regeneration are common in some species.

(iii) *Hirudinoidea* (leeches) : They are cylindrical or flattened worms with a sucker at each end of the body. The body segments have many secondary annuli. There are no setae or parapodia. While majority are free-living predatory species, many leeches lead ectoparasitic life. The suckers serve for locomotion, attachment and feeding. Although there are a few marine and brackish water (Piscicolidae) forms, the majority of aquatic leeches inhabit freshwater (Glossiphoniidae, Erpobdellidae). Freshwater forms are found clinging to submerged vegetation and stones and on aquatic animals in ponds, lakes and streams. The terrestrial species (Haemadipsidea), which are mainly parasitic on vertebrates, occur in various kinds of vegetation in humid environs. Like Oligochaetes, they are hermaphrodites.

Collection

(i) *Polychaeta* : During low tide, many burrowing species in sand or mud may be collected by turning it over with the spade and carefully prying a clod with fingers, avoiding any injury to small and delicate species. Crevices of rocks and corals can sometimes be prised open with a crow-bar to reveal

the worms. Alternatively, bleaching powder in rock-crevices and among corals will induce them to leave their burrows. Some weed-dwelling and rock-encrusting polychaetes can easily be flushed out by thoroughly washing these objects in a bucket of sea water. Immersion of chips of rocks/corals in a basin of diluted sea water (75 parts sea water, 25 parts freshwater) will make the rock-boring species come out in the water from where they can be easily collected. The tubes of the worms should, as far as possible, be retained with the specimens. Depending upon the substratum, deeper forms are collected by various types of dredges (Rectangular Dredge, Anchor Dredge), grabs (Petersen Grab) or snappers. Sometimes diving techniques are necessary to collect worms from a hard bottom. A diver equipped with self-contained underwater breathing apparatus (SCUBA) can directly pick up free dwelling worms with blunt forceps from the rock surface, or if sessile, detach them with the aid of a knife. The pelagic species are attracted towards light at night and captured with a tow net of fine mesh.

(ii) *Oligochaeta* Earthworms are collected by digging soil with a shovel or spade or any other suitable equipment. They can be obtained by hand-sorting from soil, dung, moss, leaf litter and decaying vegetation, etc. at damp places. Diluted solutions of irritating chemicals like formalin (0.55% solution prepared by adding 25 ml of formalin or 40% formaldehyde solution in 4.5 litres water), potassium permanganate (1.5g/litre), etc. are often used to extract earthworms from soil. Enchytraeids (potworms) are collected by examining samples of soil or organic matter under a binocular microscope. Special kinds of extracting funnels (Nielsen Extractor, Baermann Funnel, Wet Funnel Extractor) are also employed for their

extraction on a large scale. For aquatic forms examination of roots and stems of submerged plants and washing of bottom sediments through a series of sieves are essential.

(iii) *Hirudinoidea* Both land and aquatic leeches are collected from the bodies of animals to which they are attached. It is often difficult to remove them from the host, but application of a little alcohol, formalin or even common salt will usually induce them to release their hold very quickly. Unattached terrestrial forms can be picked up with forceps in a forest, during the rains. They are also caught by sweeping the humid vegetation with a thick-meshed hand net. Freshwater leeches living under stones and among submerged vegetation may be captured with forceps.

Narcotisation

(i) *Polychaeta* Narcotise by adding very gradually small quantities of alcohol (5-10%) to the vessel of sea water containing worms. Care should be taken to add not more than a tenth of alcohol of the total volume of sea water, otherwise the worms are liable to be killed before narcotization. Cocaine, chloral hydrate and menthol may also be used for the above purpose. To avoid contraction of large-sized species, they may first be kept well stretched in weak alcohol (30-40%), and as soon as they cease to react they should be transferred in 70-90% alcohol.

(ii) *Oligochaeta* Earthworms are narcotised as in polychaetes but using freshwater. Aquatic species (including Enchytraeidae) are washed and placed in a dish containing freshwater. After a little while, they will tend to extend and are killed by pouring concentrated formalin to the water. Some

workers advocate killing earthworms by dropping them in 70% ethyl alcohol. When the worms become motionless, they are removed from alcohol and placed on a piece of blotting paper or any other absorbent paper in straight position for fixation.

(iii) *Hirudinoidea* Leeches must be relaxed before they are preserved. They are placed in a jar with a small quantity of water and are narcotised very gradually by adding 5-10% ethyl alcohol or chloroform or chloral hydrate or weak nicotine or magnesium sulphate or carbon dioxide or even weak acids like lemon juice. They are transferred to a shallow dish and straightened out before fixation. Small leeches can be extended by compressing them between two microscopic slides held together with rubber bands or thread. These can then be killed by immersing the slides in the fixative.

Fixing and preservation

(i) *Polychaeta* Before fixing, the narcotised worms should be kept well stretched with a brush or a pair of forceps. The best fixative and preservative for polychaetes is 70-80% alcohol. To ensure proper preservation, the worms should completely be submerged in alcohol, which must be changed after a few days. The pelagic forms can be killed and preserved in a solution of 5% buffered formalin. For anatomical studies, fixation of specimens in Bouin's (75 ml of saturated aqueous solution of picric acid, 25 ml formalin and 5 ml glacial acetic acid) or Zenker's fluid (5 g mercuric chloride, 5 ml glacial acetic acid, 2 g potassium dichromate, 1 g sodium sulphate and 100 ml distilled water) is recommended.

(ii) *Oligochaeta* The narcotised earthworms are transferred to a flat bottomed container with 10-15% formalin

for fixation for a period of at least 24 hours. It is essential that the worms be straight because curled or twisted specimens are difficult to handle during dissection. The specimens after fixation are preserved in suitable sized vials or bottles filled with 70% ethyl alcohol or 10-15% formalin depending upon the size of the worms.

(iii) *Hirudinoidea* When completely narcotised, the leeches are rapidly passed between a piece of cloth or fingers to remove excess of mucous, care being taken not to damage the specimens. They are straightened out between two glass slides lightly bound together with rubber bands or thread so as to prevent distortion. The leeches are then transferred to a shallow dish containing the fixative, i.e. 50% alcohol or 4% formalin. After they are completely hardened they are preserved in 70-90% alcohol or 4% formalin.

Labelling and packing

After preservation, the specimens are stored in glass tubes, bottles or jars in which a label is placed giving details of exact locality, date of collection, name of the host (in case of parasitic forms), name of the collector, etc. For earthworms, it is sometimes desirable to give details of soil texture and depth of soil from where they were collected, and also, if possible the shapes of castings formed by them. Write the label on strong quality white drawing or cartridge sheet in black water proof Indian ink or by a soft black lead pencil. The tubes should then be plugged securely with absorbent cotton and stored upside down in a jar filled with sufficient quantity of preservative. The bottom of the jar should have a thick wad of cotton to absorb shocks.

For transportation, each tube must be corked and sealed with paraffin wax, and wrapped in absorbent cotton. Pack these tubes in a stout wooden or tin box with sufficient padding of cotton, jute, paper-shavings, saw-dust or thermocol pellets, etc. to avoid breakage during the transit.

Crustacea

Class Crustacea comprises of animals with biramous appendages and mandibles. They include water fleas, Amphipods, isopods, copepods, crabs, prawns and lobsters. These animals exhibit a great diversity of structure, habits, habitats and development. They occur worldwide from deserts to intertidal areas and from the littoral zone to deepest part of the oceans. The size ranges from 0.25 mm (Cladocera) to 360 cm (Japanese spider crab). They are free living, sedentary, parasitic or symbionts. Sexes are usually separate and develop with a typical nauplius larva.

Habitat

Aquatic Crustacea : Members of the orders Anostraca (Fairy shrimps), Notostraca (tadpole shrimps) and Conchostraca (clam shrimps) are found in temporary fresh water pools. Some (cladocerans) are found both in fresh water and inshore marine water. The fresh and marine ostracods (seed shrimps) are benthic burrowers or epibenthic crawlers, some also swim and are wholly planktonic.

Majority of the species of copepods live both in marine and freshwater habitats and are planktonic. A large number of crustaceans occur in the intertidal areas of marine and estuarine waters (amphipods, copepods, anomurans, brachyurans, etc.). Some are sessile (cirripedes) and are found attached to rocks, pilings, buoys and other floating objects in the intertidal and subtidal zones. Some (crabs) live under the stones and boulders

or in crevices of rocks and also in burrows. Wood boring crustaceans, like *Limnoria* and *Sphaeroma* bore into submerged timbers, and are destructive.

Terrestrial crustacea : Many species of isopods commonly known as sow bugs or pill bugs inhabit the terrestrial environment. They live under the leaves, flower pots, bricks and stones in the garden and among the decaying vegetable matter. Many crabs and hermit crabs are also found on land, mangrove forests and other marshy areas. Ostracods may occur in caves or in damp terrestrial habitats such as moss and leaf-litter.

Parasitic crustacea : The caligoid copepods are entirely parasitic, mainly on fishes. All members of the class Branchiura live as ectoparasites on marine and freshwater fishes. Some members of cirripedes (*Sacculina*) are also parasitic on crabs.

Collection

The smaller, free-swimming, freshwater forms (Anostraca, Notostraca and Conchostraca) may be collected by using a conventional net. For collecting the planktonic forms (cladocerans, ostracods, copepods and mysids), a plankton net of small mesh size which can be towed slowly behind a boat may be used. The weed inhabiting cladocerans and ostracods may be collected with a fine meshed hand net by sweeping through the water weeds. For collecting benthic ostracods, an ordinary small-sized Naturalists dredge can be used.

Rich collections of crustaceans can be made from the intertidal areas. Most forms from these areas can be collected by

hand sampling. A large number of copepods and amphipods can be collected from the weeds in the intertidal areas. Vigorous rinsing of seaweed tufts in sea water in a tray containing a few drops of formalin dislodges the inhabiting crustaceans which can be pipetted out from the container. Animals (alpheids, prawns and crabs) that are found in rocks and tide pools can be collected with a fine meshed hand net and a wide-bore pipette. The animals hiding in narrow crevices can be made to leave the crevices by squirting in a weak solution of formalin (1-2%) or by dropping a little bleaching powder. Some of the large burrowing animals (crabs and mud shrimp callianassids) can be induced to come out of the burrows by placing pieces of fresh crab meat near the burrow entrance. Sessile forms (cirripeds) may be scraped off from the substratum by a metal scrapper or a knife.

For collecting the shallow and deepwater benthic crustaceans dredges and trawls are used (Naturalist's dredge, Bottom or Otter trawl). Many epibenthic crustaceans that live crawling on the bottom or near the bottom, like stomatopods, lobsters, prawns and crabs, are collected by trawling. For collecting burrowing crustaceans from the shallow and deep waters, Peterson's grab is used.

Terrestrial isopods are collected by digging the upper layers of soil and by examining the under surface of stones and other decaying organic matter in damp places. Parasitic forms can be collected from the fins, eyesockets, mouth and gill cavities of many fishes. These parasites can be removed from their host's with the help of fine forceps, camel-hair brush or by a mounting needle. While removing parasites from the host, care should be taken not to damage the area of attachment apparatus.

For proper identification of the parasites, name of the host is very important.

Preservation

Before preservation, the animals should be washed thoroughly and note the colour pattern. These colour markings may disappear after killing and preservation.

Freshwater forms like members of Anostraca, Notostraca, Conchostraca, Cladocera and Ostracoda can be killed by adding a little quantity of formalin to water. Then these may be transferred to 70-90 percent alcohol for preservation.

Planktonic forms are killed in 1-2% solution of formaldehyde. Once the animals are dead they are preserved in 5% buffered formalin solution.

Decapod crustaceans like crabs, lobsters and shrimps need special care in killing. They usually shed their appendages when dropped directly in concentrated formalin or alcohol. This can be avoided if a weak solution of 1-2% of formaldehyde is used. After killing, large specimens should be fixed in 5% buffered formaldehyde solution for three or four days. After fixation the animals are washed thoroughly in water and transferred to 70-90 percent ethyl alcohol.

If needed for histological studies, smaller forms may be preserved in Bouin's fluid and kept in 70-90% ethyl alcohol.

Labelling

Proper labelling of the specimen is of extreme importance. Labels should be written on good quality paper (cartridge paper) with a soft pencil (for temporary labels) or with Indian ink (for

permanent labels). Each label should bear essential informations such as exact locality (place name, district, state) date of collection, station number and name of the collector. If it is collected during the expedition, additional informations like name of the ship, cruise number, nature of the ground for benthic animals, type of gear used, data on depth, etc., may be included. After proper labelling specimens are stored in glass tubes, bottles or jars, depending upon the size of the specimens.

Packing for despatch

For despatch, tubes or bottles should be sealed with melted wax to avoid leakage of preservatives and loosening of cork. Each tube should be wrapped individually in tissue paper or cloth and tied with white thread before packing in a stout wooden box. Pack the spaces between the tubes with cotton wool to prevent rattling and damage. The wooden box should be well padded with fine cotton wool, soft crumpled paper and jute fibres to absorb shocks during transit.

Introduction to Insects

The World of Insects present a fascinating panorama of living natural resources. Insects outnumber, in today's world, all other living forms and can be said to represent the perfect adaptation in all possible ecological niches. The geographical location of India between $8^{\circ}4'N$ and $36^{\circ}6'N$, provides a wide latitudinal extent, offering a range of climatic conditions. The altitudinal variations along with other biotic and abiotic factors lead to an array of insect-faunal elements.

India can be divided into 9 major floristic regions and till now some areas under each region remain moderately explored or unexplored. The forest types of India, with 4 major groups and 16 subgroups, represented in different areas of the country, can help to formulate a systematic survey of insect fauna.

Survey, collection and preservation

To collect insects during field survey, one has to use a variety of methods. These may be broadly listed as follows: Handpicking; Sweeping and beating; Collecting with aerial nets; Trapping; Using Berlese funnel and separator.

Hand picking : Small insects, specially the soft-bodied ones are best collected by hand either with the help of a fine camel hair brush or by a pair of forceps. The soft brush is normally dipped in the medium in which the insects are going to be preserved, so as to minimise the damage to soft skin. Forceps can be used carefully to avoid damage to the insects as in the cases of ants and many insect larvae. Hand picking needs

searching in particular habitat and as such offer excellent data for biology. Insects like leaf-miners (Diptera), aphids (Hemiptera), bark inhabiting beetles, insects living under stones and vegetable (Dermaptera and Coleoptera), termites (Isoptera), and ants (Hymenoptera), etc., are only collected by hand picking.

Sweeping : Sweeping with a proper net yields satisfactory result while collecting insects from herbage. It has been regarded as the most efficient method for rapid collection of free living insects in large numbers. Sweeping nets, because the way they are used, must be of strong cloth. A 60 cm long handle with 50 cm depth bag may give satisfactory result. The disadvantage of sweeping method has mainly been that it does not offer host plant data or specific habitat of an insect species, and insects that live within flower, leaves or near ground level can not be collected by a sweeping net.

Beating : Beating is usually employed to dislodge insects from foliage or trees. Usually a long stick is used to beat the plant parts with downward strokes and a tray or cloth is kept or spread over the ground to fetch the falling insects. A net may also be kept on the ground to prevent crawling or jumping insects escape, after they fall to the ground.

Aerial netting : Aerial nets are most widely used to collect free living flying insects e.g. Odonata, Lepidoptera, Hymenoptera, Diptera, etc. The length of handle, diameter of ring, depth of the net may vary on individual collectors' preference. But normally strong, light, easily manouverable handle with 38-45 cm diameter ring and strong, durable, nylon bags are used with a depth which is at least twice the diameter of the ring used. Soft-bodied insects like Lepidoptera may be

gently removed from the bottom of the bag, after it becomes enclosed in the bag by a rapid twist of the handle; often the fold of the net enclosing the insect may also be inserted into the killing bottle and the insects may be removed after they are killed by vapour of the killing agent.

Collecting with aspirator : Small active insects like leafhoppers, white flies, other Hemiptera and Coleoptera, etc., may be collected by a sucking tube or aspirator, straight from the plant surface. It is a very simple device and if used with little patience and caution may yield desirable result. It is also useful to transfer insects from sweeping nets or from rearing cages. All that one has to do is to suck the air by rubber tubing which would draw the insect into the main tube through the glass tube. The lid of the main tube may be removed and the entire content may be put inside a killing bottle.

Trapping : Traps are used to get insects which may otherwise evade attention and also to study migration, aerial dispersal and other biological phenomenon. Various types of insect traps are known which may be broadly grouped into following categories : Traps without bait or light (*Wind Trap, Water Trap*); Traps with bait (*Pitfall Trap*); Traps with light (*Light Trap*).

Wind traps may range between a simple sock attached to a pole in the direction of wind or may be a electrically operated suction device. In India, not much of insect collections have been made by wind traps. Yellow Pan Water trap is a simple device to attract insect to the preferable colour, in which the pan is painted in case of aphids. It is simply a metal tray painted in yellow and half filled up with water; insects being attracted to colour, fall into the water.

The odour of the particular kind, food or sex hormone, act as the principal agent in bait traps. Baits may include over-ripe fruit, piece of meat or fish, rotten fungi, animal excreta, etc., and these may be put in convenient location where the insects would congregate. One of the simplest form is pit fall trap where a jar containing bait is placed below the soil level, to catch crawling insects like roaches, ground beetles, ants, etc.

Bait traps may also be used for flying insects; a simple device is to put a metal funnel, with bait suspended at the top level, inside a killing bottle, which would attract the hovering insects. Sex-hormones when used in field-traps may attract thousands of insects, like saw-flies of opposite sex.

An artificial light like Petromax gas light if placed adjacent to a white mulmul cloth in field would attract a number of insects like gryllids, grasshoppers, moths, mantids, beetles, etc. Most of the insects attracted to the light would rest on the white cloth from where they may easily be pickcd up by hand or by aspirator. "Black light" traps are also used to collect insects at night. Simplest form would be to suspend a light source over a broad rimmed funnel which in turn may be fitted to a glass jar containing poison-vapour or other killing agents. Light traps may work all night and may also supply data indicating seasonal incidence, peak period for a population, etc.

Berlese funnel : Insects inhabiting leaf litter and subsoil or inside the soil level are collected along with a part of the soil and brought to the laboratory where they are usually put in a funnel which acts as a separator. Several modifications of this device, known as "Berlese funnel" are now available, the simplest form being a metal funnel with sieve, inserted inside a

can or collecting tube. The material (moss, debris, litter) is put on the sieve which is subjected to continuous heating by light bulb; the collecting tube contains preserving fluid like alcohol and the tip of the funnel touches the fluid. Insects in order to evade the heat move down through the sieve and fall into the preservative.

Equipments

Net : A net essentially consists of a cloth bag or nylon net bag, a metal ring which holds the mouth of the open-bag, and a handle to which the metal ring is attached. Usually a ring of 38 cm diameter made up of 3 mm thick wire or metal is used; the ends of the ring should fit into a groove at the end of handle; the detachable ring allows the change of a dirty bag or a torn one. The depth of the bag is usually 75 cm or twice the diameter of the ring. The handle should be sturdy but light.

For sweeping purpose, the bag used is of thick cloth instead of nylon net and the handle should also be stouter to allow quick sweep over vegetation. It may be a 20 cm ring, with 45 cm handle and a bag of 30-35 cm depth.

Brush, Forceps, Twigcutter, Scissors : Soft camel hair brush of No. 0 or 1 is usually used for hand collection. A pair of forceps with bent end or straight end is used to pick up insects from surface. For collecting ants, thin, fine, light weight forceps yield better result. A scissor or twigcutter may be used to cut plant-part or twigs.

Aspirator : A simple field equipment made up of a collection jar, having two holes at the cork stopper through one of which a bent glass tube (intake tube) is inserted and through

the other a rubber tubing at the end of a small straight glass tube (suction tube) is fitted. Insects may be sucked in by putting the intake tube near its body and sucking the air through the rubber tube.

Axe, Knife, Hammer : These are necessary tools for collecting insects inhabiting soil, termite mound, under bark and rotten log. These are used to tear off loose bark or split wood or to break open the mound or to dig out the borers and miners.

Killing Bottles : Killing bottles are used to kill and preserve insects without affecting its colour. Usually glass jar with a layer of Na or K cyanide covered with plaster of paris, is used as a killing bottle. Cyanide vapour however may make small specimens brittle and even change its colour. Very often some other liquid chemicals like Chloroform, Benzene, Ether, Carbon Tetrachloride are used. Each one of these has some disadvantage but, in general, their vapours serve the purpose of killing the insects. The liquid may be poured over a layer of cotton wool, and one or two filter papers or blotting papers could cover the soaked cotton and also prevent the specimen from coming in direct contact with cotton. Insects must be handled carefully while they are put inside the bottle or taken out to prevent damage. A killing bottle, with a layer of small chips and saw dust soaked with a few drops of ethyl acetate serves satisfactorily for a number of insects in killing and preserving the specimen which remain flexible.

Collection vials : Small specimens, which are killed and preserved in liquid, are to be kept in Homeopathic vial or similar other vials. Vials with screw plastic caps are preferable.

These may be numbered beforehand and the corresponding number in the field note book may contain details about that particular collection.

· **Hand lens** : A 10x hand lens (folding type) is useful to examine material in the field and should be kept handy.

Paper packets : Paper packets are used to keep lepidopterans, odonates and many other insects. As soon as they are killed, specimens are transferred to these packets, made up of oil-paper, for temporary storing and transportation. These may be prepared in desirable sizes before one proceeds for field collection.

Chemicals and cotton : During field collection, preservative like 90% ethyl alcohol, killing agents like benzene or chloroform, or ethyl acetate should be carried extra, to meet any emergency; cotton may be required for packing after collecting or to change the killing agent in the killing jar and should be kept handy.

Traps : Pitfall traps or Yellow Pan Water traps have already been discussed. The latter is a shallow pan trap painted yellow, which should be filled up to the half with water before being placed in the field. Petromax lamps are handy for light trapping and could be carried easily and used specially where electricity is not available.

White tray, Sieve tray : These may be useful to sort out debris, litter and aquatic collection during preliminary examination. After checking the material, the useless parts may be eliminated by sieving, and the samples may be put in Berlese funnel.

Haver-sack, Boot, Camera : The equipments could best be carried in a Haver-sack. However, a jacket which a collector may wear may be tailor-made, with specifications to suit the need. A number of small pockets to keep the collecting instruments handy may be provided in the jacket. One can get various kinds of other handy equipments from shops of fishing equipments *viz.* fisherman jacket, bags, fishing nets, etc. A good quality hunting rubber soled boots, would immensely help while going to the field. A field camera with f. 1.4 or f. 1.8 lens and a set of close-up accessories would be very useful for photographing ecological conditions, insect community, feeding site, habitat and other observations.

Field note book : A field note book is most essential for keeping all the data. Generally a numbered tag may be attached with collection and the same number in the field note book may be used to keep the following data : (i) Date of collection, (ii) Place of collection - indicate direction, approximate distance in km. from nearest road head and altitude, (iii) Habitat, (iv) Colour of live specimens, (v) Name of host plant or animal, (vi) Associated insects or animals and (vii) Name of collector, etc. A general note on the collection locality would provide further information, say about a reserve Forest area, its vegetation type, etc.

Collections, once made, are to be preserved in a manner which provides scope to examine the specimens for identification and study and also guarantees long period of storage, with proper care. Table 1 provides in brief the methods of collection, and preservation of major insect groups, details of which are given by subject specialist in subsequent chapters.

TABLE 1 : COLLECTION AND PRESERVATION

GROUP	COLLECTION	KILLING	PRESERVATION
1	2	3	4
I. Apterygota	By aspirator tullgren funnel	95% alcohol/CHCl ₃	80% alcohol
(1) Thysanura	" Camel hair brush dipped in alcohol	CCl ₄	
(2) Diplura	" aspirator/extractor		
(3) Protura	" extracting soil		
(4) Collembola	" Putting soil, debris, leaf litter in tullgren funnel/hand picking		
II. (5) Dictyoptera	By Sweeping/hand picking	Cyanide vapour or	(5) + (6) Dry, pinned
(6) Orthoptera	" sweeping	Chloroform vapour or	or in alcohol (7)
(7) Dermaptera	" forceps	Benzene vapour	
	" flashlight	Acetic ether	
III. (8) Plecoptera	By netting while on wings	95% alcohol	80% alcohol
	" sweeping		
	" light		
IV. (9) Isoptera	By forcep from nest	95% alcohol	80% alcohol
	" brush dipped in alcohol		
V.(10) Embioptera	By forceps	95% alcohol	80% alcohol
	" brush		
VI. (11) Ephemeroptera	By nets (adults)	95% alcohol	80% alcohol
	" light trap (adults)		
	" beating (subimago stage)		
VII. (12) Odonata	By aerial nets	Cyanide or ether	Dry pinned, 80%
VIII. (13) Zoraptera	By brush dipped in alcohol	95% alcohol	alcohol, 80%
(14) Psocoptera	" aspirators	(scale covered winged specimens in vapour and preserve dry)	alcohol
IX. (15) Phthiraptera	By brush dipped in alcohol	95% alcohol	80% alcohol and
	" fine forcep (from freshly killed animal wrapped in polythene bag or directly from fur and skin)		mount on slides by clearing in 10% KOH ₂ passing through alcohol grades and mounted in Canada balsam
X. (16) Thysanoptera	By brush dipped in 80% alcohol or in a mixture of Ethyl alcohol (50%) lactic acid (10%) water (40%)	95% alcohol or in mixture	80% alcohol or mount in Poly-vinyl lacto phenol method or in Hoyers media.
	" Berlese Funnel extraction		
	" Beating flower on white sheet or over wide mouth jar.		
XI. (17) Hemiptera	By sweeping net and aquatic net	95% alcohol or kill in cyanide bottle or in vapour Ethyl acetate	80% alcohol or mount in slides (Berlese media) or pia
	" beating		
	" aspirator		
	" brush dipped in alcohol		
	" light trap		
	" separator		

1	2	3	4
(18) Neuroptera	By netting " sweeping " hand picking " light	Cyanide or other vapour	Pinned
(19) Mecoptera	By aerial net " Light trap	Cyanide or other vapour or in 70% alcohol	Pinned or wet preservative
(20) Trichoptera	By aerial net " light trap	Cyanide vapour or 95% alcohol	Pinned and spread or 80% alcohol
(21) Lepidoptera	By aerial net " light trap " Sugar-baits or sap, nectar bait " rearing larvae or pupae	Cyanide vapour	Pinned and spread
(22) Coleoptera	By sweeping " hand picking " beating " aquatic net	Cyanide vapour, 95% alcohol (all aquatic forms), Vapour Ethyl acetate.	Pinned or in 70% alcohol
(23) Strepsiptera	From parasitised host (Hemiptera, Hymenoptera, Orthoptera).	95% alcohol	80% alcohol
(24) Hymenoptera	By rearing (parasitic forms) host insects " beating " sweeping " light trap " aspirator (ants) " Berlese funnel (ants)	Cyanide vapour, Ethyl acetate vapour (microhymenoptera)	Pinned or pointed, mounted on slide
(25) Diptera	By sweeping " aerial net " aspirator " light trap " baiting (meat, dung, rotten fruit, fungi) " Berlese funnel " collecting galls and mines (midges, miners)	Cyanide vapour, 95% alcohol	Pinned or pointed, 80% alcohol, permanent mount of genitalia.
(26) Siphonoptera	By shooting and trapping hosts " searching in hosts nests	95% alcohol	80% alcohol, Permanent mount on slides, after cleaning in 10% KOH.

Notes :

1. In many instances, the genitalia of the insect has to be taken out for taxonomic study (Orthoptera, Lepidoptera, Neuroptera, etc.) and this involves careful dissection; the genitalia after being dissected out could either be stored in microvial in glycerine or may also be mounted on slide or mounting card as permanent preparation, passing through alcohol grades, clove oil, xylol and mounting in resinous substance.
2. Cyanide vapour is often disliked by many collectors and as such other agents e.g., Ethyl acetate, Chloroform, Ether, Benzene, Carbon tetrachloride may be used in killing bottle, in cases where only cyanide vapour is recommended,

Collection and Museum Equipment

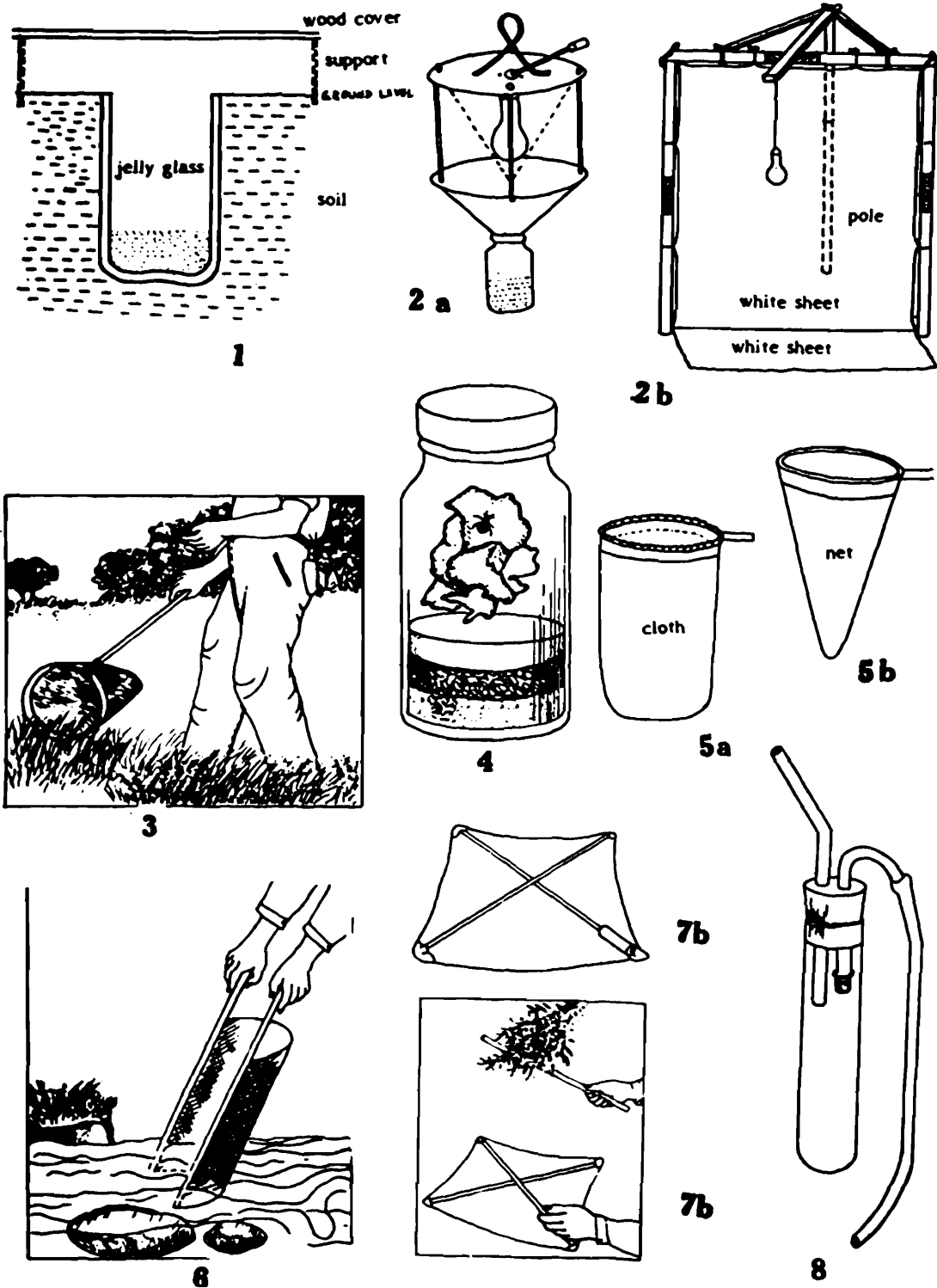

Plate I Collecting Equipment

1. Pit-fall trap; 2a, 2b. Light trap; 3. Sweeping net; 4. Killing bottle (Potassium cyanide method); 5a, 5b. Common insect nets; 6. Aquatic net; 7a, 7b. Beat net; 8. Aspirator.

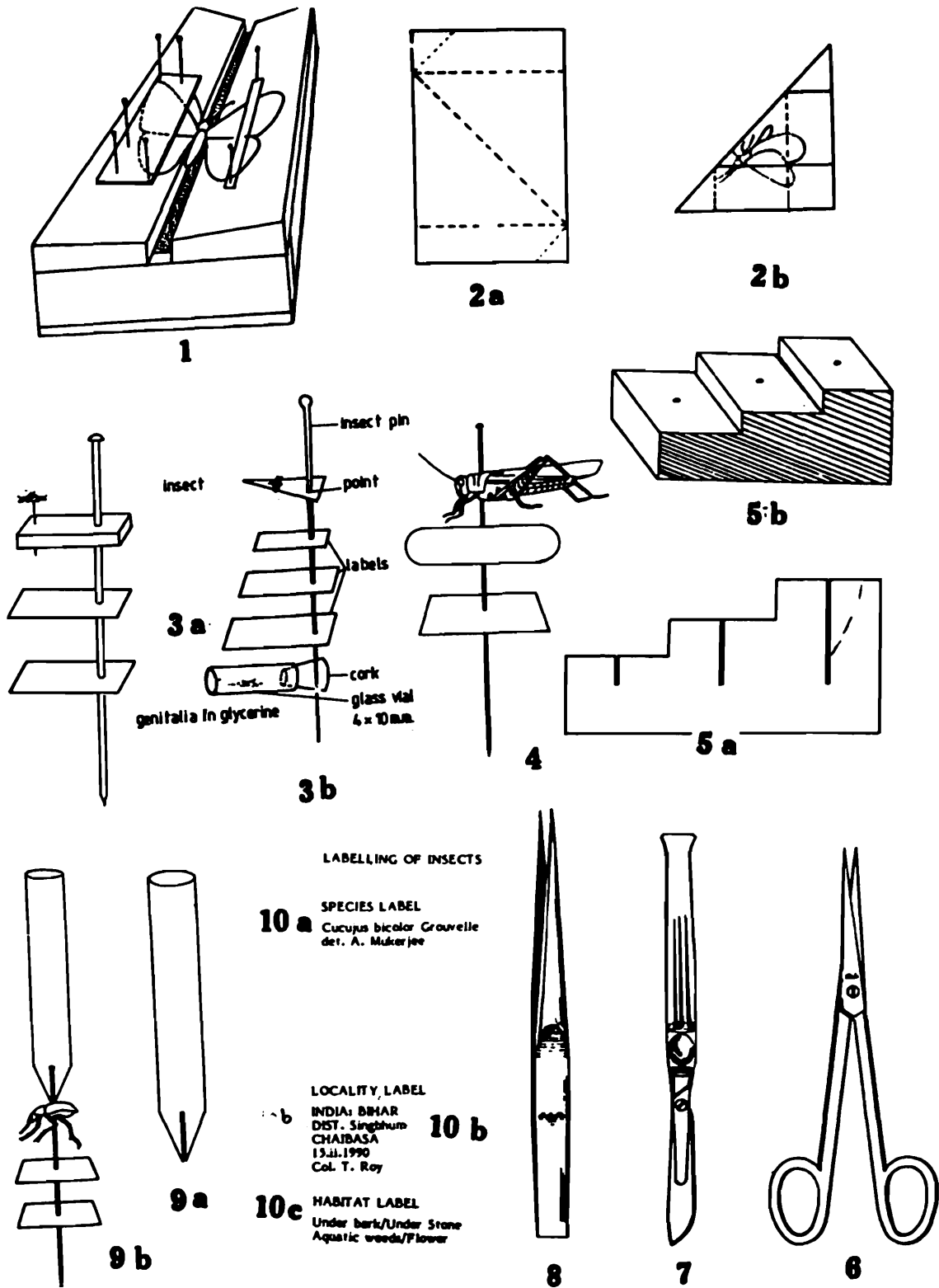

Plate II Museum Equipment (Mounting and Labelling of Insects)

1. Butterfly setting board; 2a, 2b. Paper triangular envelop for temporary storage; 3a, 3b. Mounting technique of insect; 4. Use of medical capsule for broken parts; 5a, 5b. Three step pinning block; 6. Scissors; 7. Scalpel; 8. Forceps; 9a, 9b. Pinning dowel; 10a, 10b, 10c. Labelling of insects : Species label, Locality label, Habitat label.

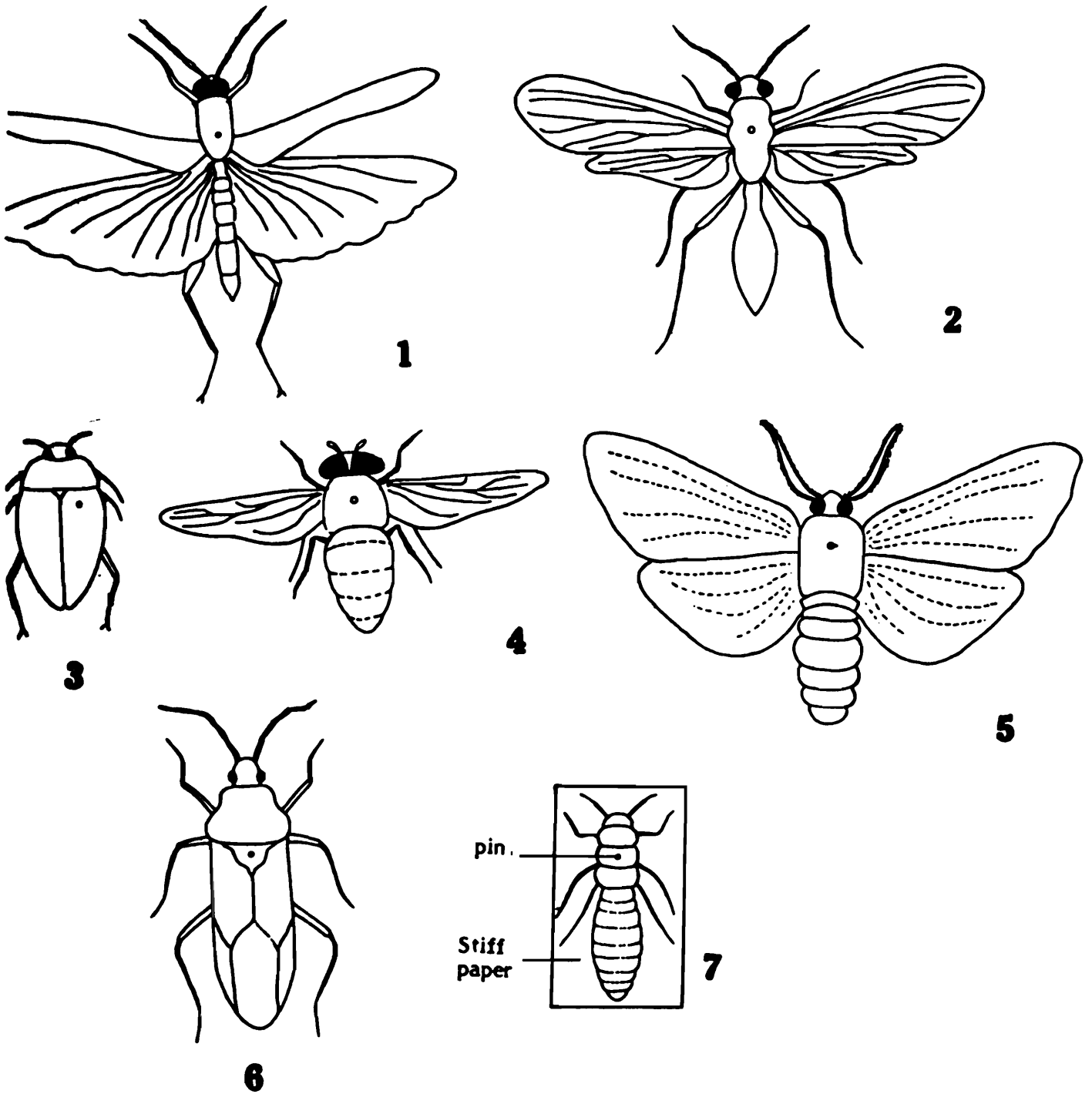

Plate III Position of Pinning Insects

1. Orthoptera; 2. Hymenoptera; 3. Coleoptera; 4. Diptera; 5. Lepidoptera; 6. Hemiptera; 7. Soft-bodied insect.

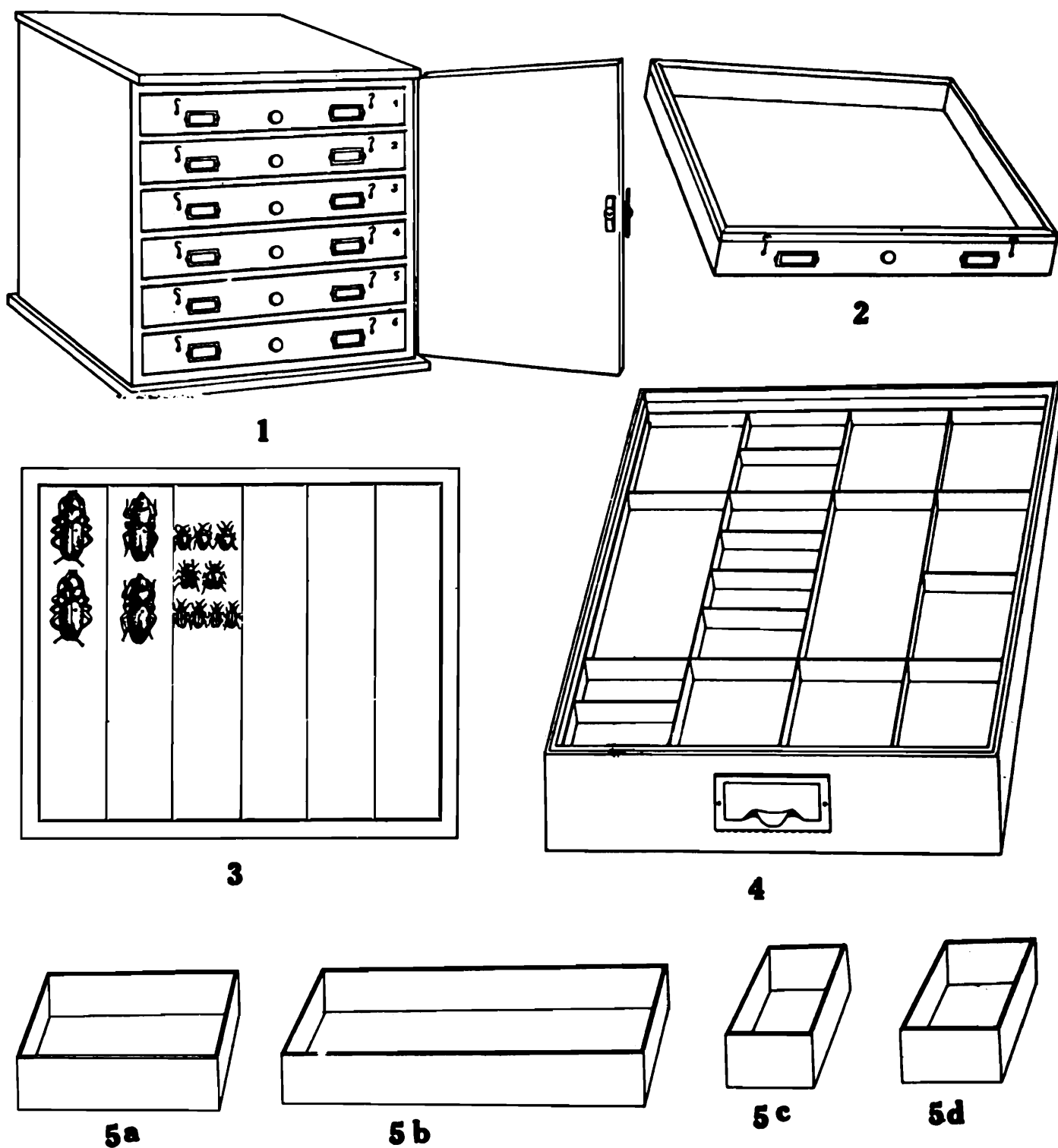

Plate IV Museum Equipment (Permanent storage)

1. Wooden insect cabinet; 2. Single drawer of a cabinet with glass top;
3. Insects arranged in an insect drawer; 4. Drawer with pinning trays;
- 5a, 5b, 5c, 5d. Pinning trays of different sizes.

Thysanura

(Silverfish)

Thysanurans are apterous, soft-bodied, fragile, minute to medium-sized (0.5 to 2 mm), dorsoventrally flattened insects, with two multi-segmented antennae. Abdomen terminating posteriorly in two long fragile bristle-like cerci and one median tail filament.

Habitat

These insects are secretive in nature and generally avoid light. They occur in household articles such as books, behind photographs and dumped clothings. In nature these are found under stones, bark of logs, leaf axils and also in the nests of ants and termites.

Collection

These fragile insects can be collected only by a specially made aspirator and the termitophilous forms and those associated with ant's nest can also be collected by indirect method, specially by the help of Tullgren Funnel.

Preservation

These insects are best narcotised first by using either vapour of liquid benzene or carbon tetrachloride, then killed and preserved in 70% ethyl alcohol.

The tubes containing collection are stored in larger jars, half filled with 70% ethyl alcohol. Stripes of soft tissue paper are

placed inside the tubes, and cotton wool in the outside jar to prevent damage through jerk.

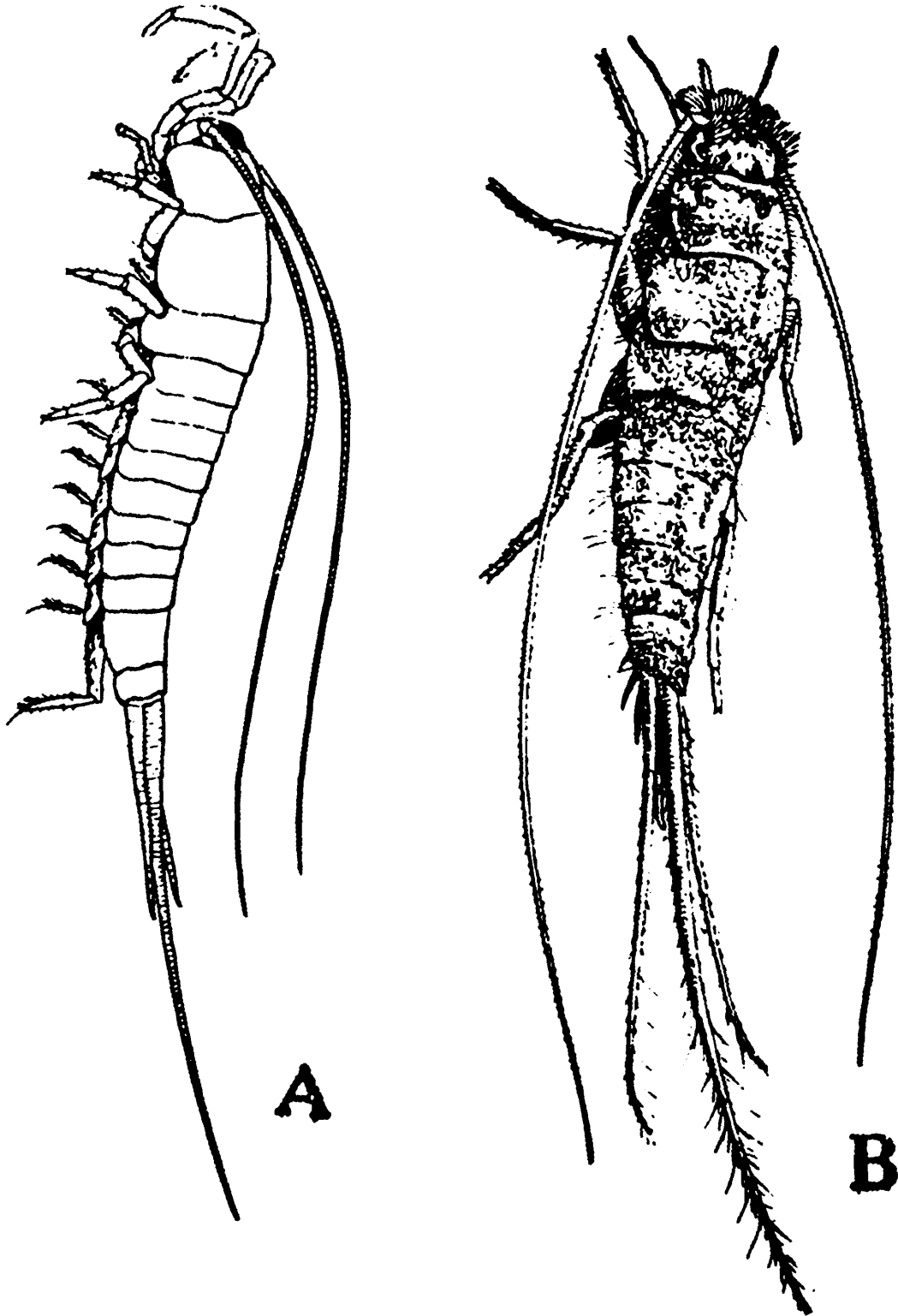

Thysanura (Bristle tail/Silverfish)

A. With scant hairs, B. With dense hairs

Diplura

(Campodeids, Japygids)

Minute (10-50 mm), wingless, unpigmented insects, with monoliform antennae, styliform appendages on most or all of the pregenital abdominal segments, and variably developed cerci or unjointed forceps.

Habitat

Inhabit moist cavities beneath stones, decaying logs, debris, deep porous litter, humus layers in forest soil, moist shaded stretch of grasslands, caves, etc.

Collection

These can be collected by using a soft brush moistened with 70% alcohol, by a pair of forceps or an aspirator. This method can also be utilised by first tapping objects harbouring diplurans and picking them from an enamel tray. Tullgren Funnel can also be used for their extraction.

Preservation

These insects are killed and preserved in 70% ethyl alcohol.

These insects are first placed in small tubes (size 2-3 × 0.5 – 1 cm), then kept in a larger tube filled with 70% alcohol, together with a label. Such large tubes are kept in a big jar containing 70% alcohol and provided with cotton padding.

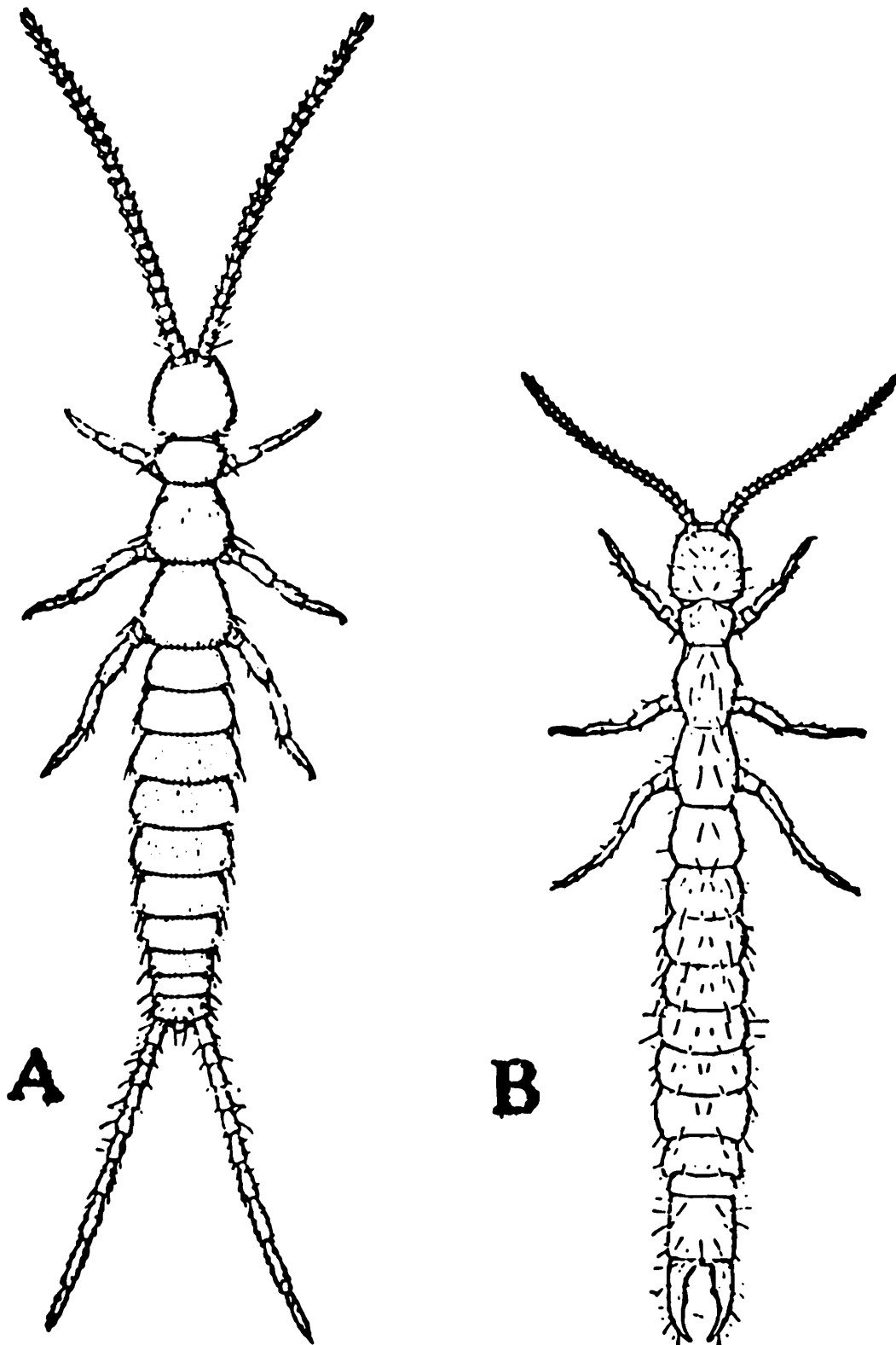

Diplura (Campodeids/Japygids)

A. With file mentous cerci, B. With forceps

Protura

(Proturans)

Minute (0.5 to 2 mm), wingless and colourless insects, with cone-shaped head, devoid of eyes and antennae; paired minute abdominal appendages present on ventral side; cerci absent; a median telson present, reduced or absent.

Habitat

These insects are found in moist forest soil, grass, humus, in peats, deciduous wood, litter, and tuft; also found under stones or loose bark and old leaf mould.

Collection

These rare insects occur between 5 cm and 20 cm deep inside the soil and can be collected by a stainless steel corer. The insects from the soil cores are then to be extracted in a modified high gradient soil extraction apparatus.

Preservation

Proturans are best killed and preserved in 70% ethyl alcohol.

Collection tubes are first placed in a large tube, having a label. Then these large tubes are kept in a container filled with 70% alcohol and provided with sufficient cotton padding.

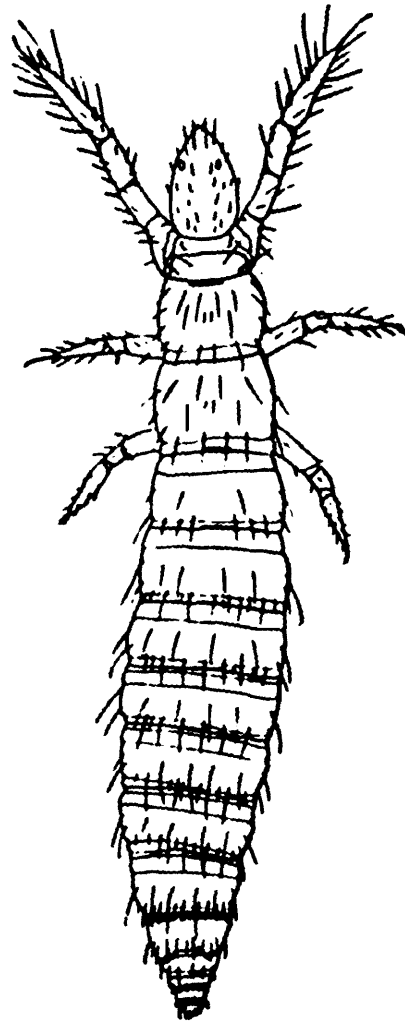

Protura (Proturans)

Collembola

(Springtail, Snow or Lucerneflies)

Collembolans are wingless, primitive insects, minute (0.2 to 5 mm) to moderate in size (8 to 10 mm), elongate or globular, with long or short antennae and inconspicuous, 6 segmented abdomen; first segment with a sucker-like ventral tube, and fourth usually with a forked springing organ.

Habitat

These insects inhabit a wide range of ecological niches. Majority live where organic matter and moisture are present such as wooden log, leaves, under stone, in caves, termite mounds, ant-nests, litter, humus, subsoil layer in forests, grass land, under loose bark of trees, leaf moulds, moss, fungus, lichens, etc. A few live on the surface of water, ponds, lakes, in the intertidal sea shore zone and on snow.

Collection

These insects can be collected directly from vegetation by a soft fine brush dipped in 70% alcohol, sucking through an aspirator or by placing a petridish or a watch glass, half filled with alcohol over soil, humus and litter, and gently disturbing the surrounding habitat. Inverting a tube wet with alcohol over a collembolan population, beating herbs or shrubs over an enamel tray half filled with alcohol or by using Tullgren Funnel.

Preservation

These are killed and preserved in 70% ethyl alcohol. These should first be narcotised with liquid benzene or chloroform or carbon tetrachloride, then preserved in 70% alcohol.

Individual vials should be kept in a larger tube containing a label and both filled with 70% alcohol. Such tubes then be placed collectively in a bigger jar, containing alcohol and cotton padding.

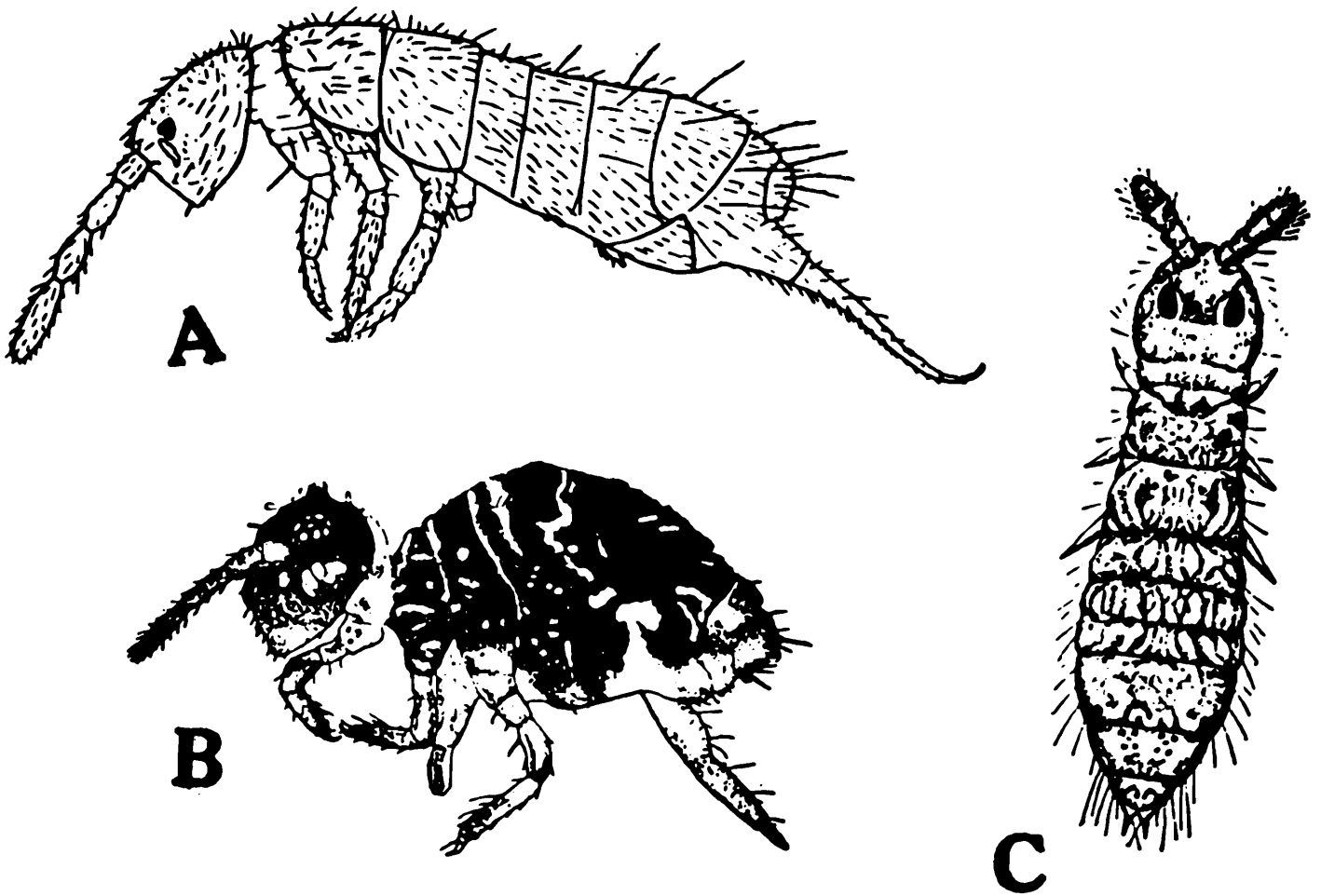

Collembola (Springtail)

A. *Arthropleona*, B. *Symphyleona*, C. With reduced springtail

Ephemeroptera

(Mayflies)

Soft bodied, minute to medium-sized (2-25 mm) insects, with minute setaceous antennae, atrophied mouth parts, two pairs of wings, hind pair sometimes small or absent, a pair of long filamentous cerci and usually with a median caudal filament. Larvae aquatic, spindle or broad-shaped, with tracheal gills.

Habitat

Adults inhabit vegetation in the vicinity of both running and stagnant water-bodies. Larvae occur in the littoral zone amongst rooted vegetation or underneath pebbles, or as benthic forms.

Collection

These insects can be collected by beating vegetation over a paper/blotting sheet. A camel hair brush or a fine forceps can be used for picking weak fliers. Suitable light source near water body attracts adults. Larvae can be collected by water nets. Scooping bottom mud and washing through sieves yields benthic forms.

Preservation

Adults are killed by exposing to benzene or cyanide vapour and preserved in 70% ethyl alcohol. Larger forms can also be preserved dry by setting and pinning. Larvae are preserved in 70% ethyl alcohol.

Tubes containing Ephemeropteran adults and larvae can be stored in large jars, filled with alcohol. Adequate cotton padding in outer jar prevents breakage. Dry specimens may be preserved in packets kept in cardboard boxes, with powdered naphthalene or in insect cabinets after they are set and pinned.

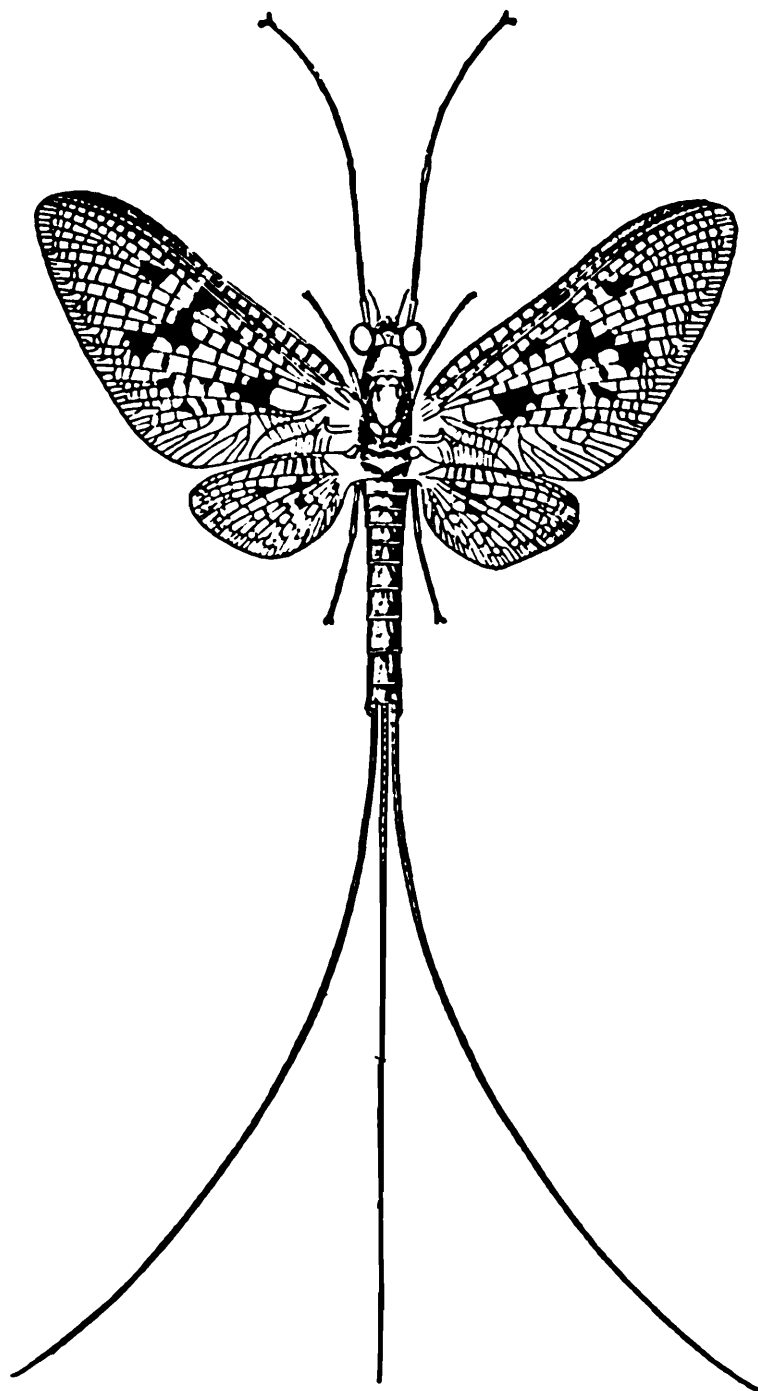

Ephemeroptera (Mayfly)

Odonata

(Dragonflies, Damselflies)

Medium to large-sized (2 to 15 cm) insects with elongate body, large eyes, minute filiform antennae, male accessory genitalia on 2nd and 3rd sternite, and ovipositor simple or strongly serrated. Two pairs of membraneous wings, glassy reticulated with node, pterostigma and numerous cross-veins. Larvae aquatic, with long, retractable and prehensile labrium and caudal gills in damselflies.

Habitat

Adults inhabit vegetation in and around water bodies, some venture far into woods. Larvae lives in the littoral zone amongst rooted vegetation or underneath pebbles, or as benthic forms on the bottom substratum.

Collection

Dragonflies can be collected by sweeping with insect nets in head backwardly action amongst grassy vegetation near water bodies. For vigorous fliers over large water bodies or those which fly at a height, only suitable method is to use small bore shotgun with dust shot cartridges. Larvae are collected by water nets amongst rooted vegetation, under pebbles and by scooping and washing bottom mud for benthic forms.

Preservation

Adults can be killed by exposing to benzene or cyanide

vapour and preserved dry. Larvae can be killed and preserved in 70% ethyl alcohol.

Adults are stored in individual packets or triangular paper packets depending on size and kept in cardboard/insect box, with powdered naphthalene. Larvae can be stored in tubes kept in jars both containing 70% ethyl alcohol. These tubes are then packed in a big jar, with sufficient packing material.

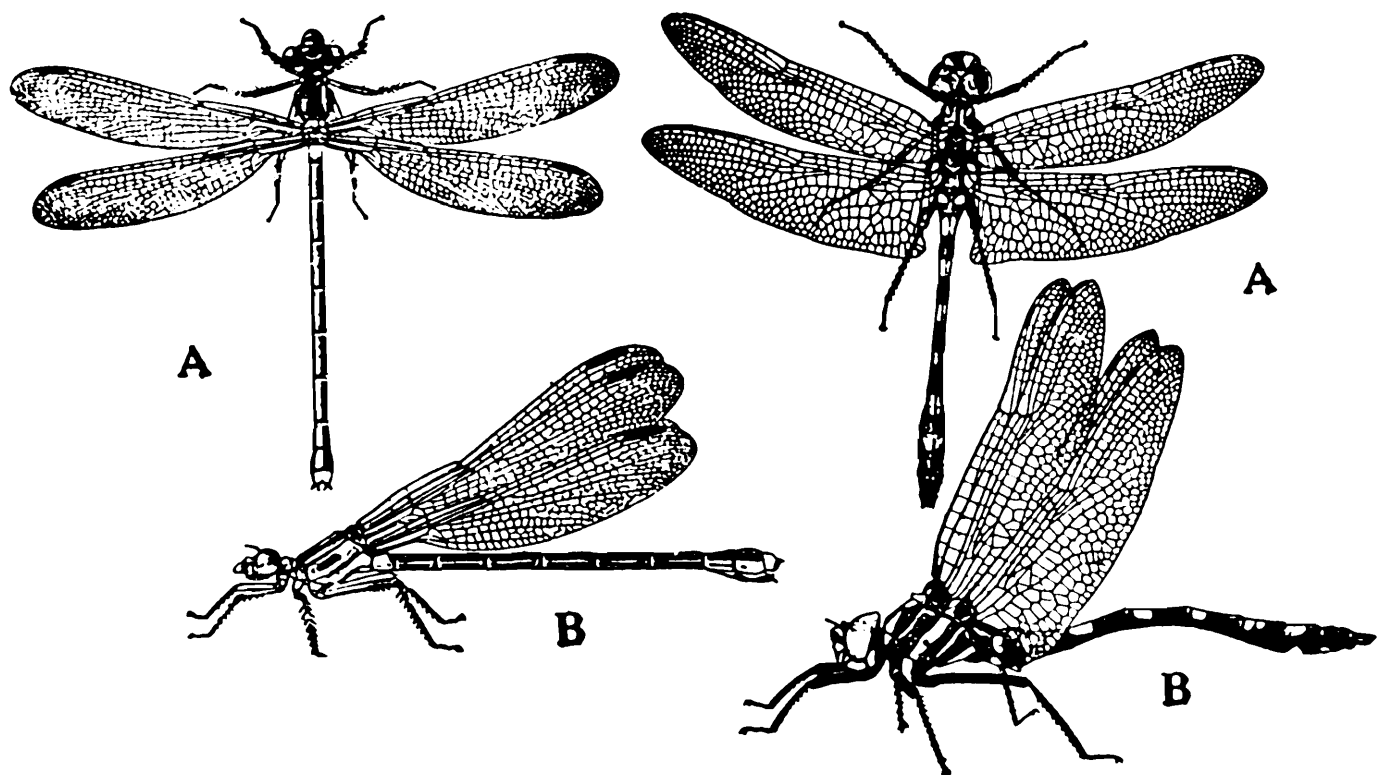

Odonata : Zygoptera (Damselfly)

A. Dorsal view; B. Lateral view.

Odonata : Anisoptera (Dragonfly)

A. Dorsal view; B. Lateral view

Plecoptera

(Stoneflies)

The adult Stone flies are usually small, with wing expanse varies between 4 and 6 cm. Wings are unequal and the forewings form a cover for the hindwings. The hindwings are with broad anal field.

Habitat

These are sluggish in habit and slow in flight. They are found at the edge of streams between stones or under them. The nymphs are entirely aquatic and mainly found in running streams. These nymphs generally cling under stones and before final moulting to imago state they come to drier places.

Collection

These insects may be caught among stones or on posts adjacent to water source by putting over them a killing tube. By beating the shrubs or by sweeping among water-side vegetation these insects may also be collected. In warm sunshine or at dusk when the adults are on flight, they may be collected by aerial netting. Use of light traps in warm nights are useful for collection.

Preservation

Both adults and nymphs of these soft-bodied insects may be preserved in 80% ethyl alcohol. However, the stone flies may be preserved in dry condition after proper setting and pinning.

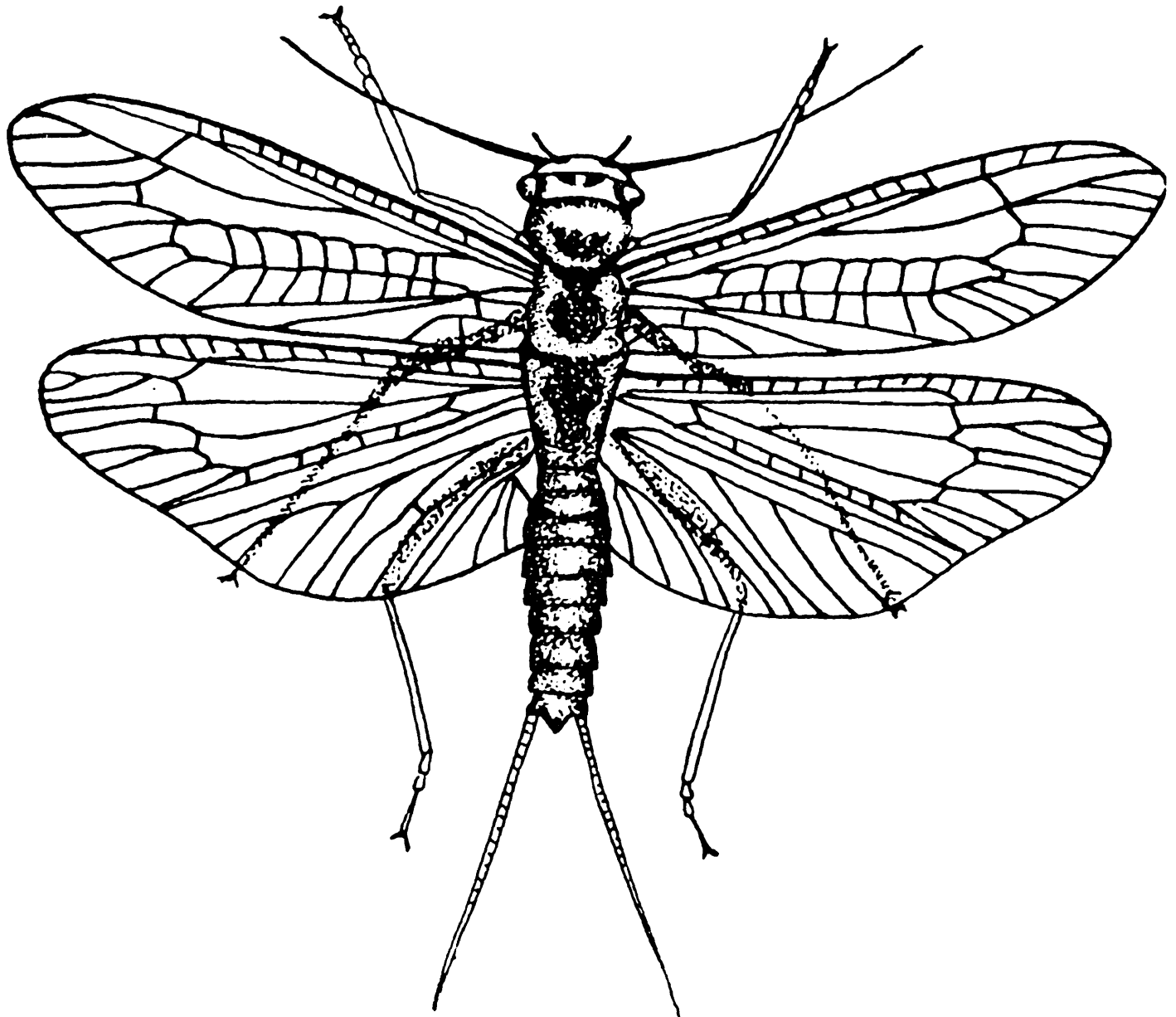

Plecoptera (Stonefly)

Phasmida

(Stick insects, Leaf insects)

Stick and leaf insects are included in this order, which are predominant in tropics. Stick insects are long and narrow, with short prothorax and long mesothorax, and often live in low vegetation. The leaf insects are flattened, with leaf-like expansion on legs, and are more common in foliage of trees and bushes. Because of their shape and protective coloration, it is often difficult to locate them in nature.

Collection

These insects may be easily picked up by a pair of fine forceps and killed by exposing to cyanide vapour.

Preservation

Stick and leaf insects are generally preserved dry.

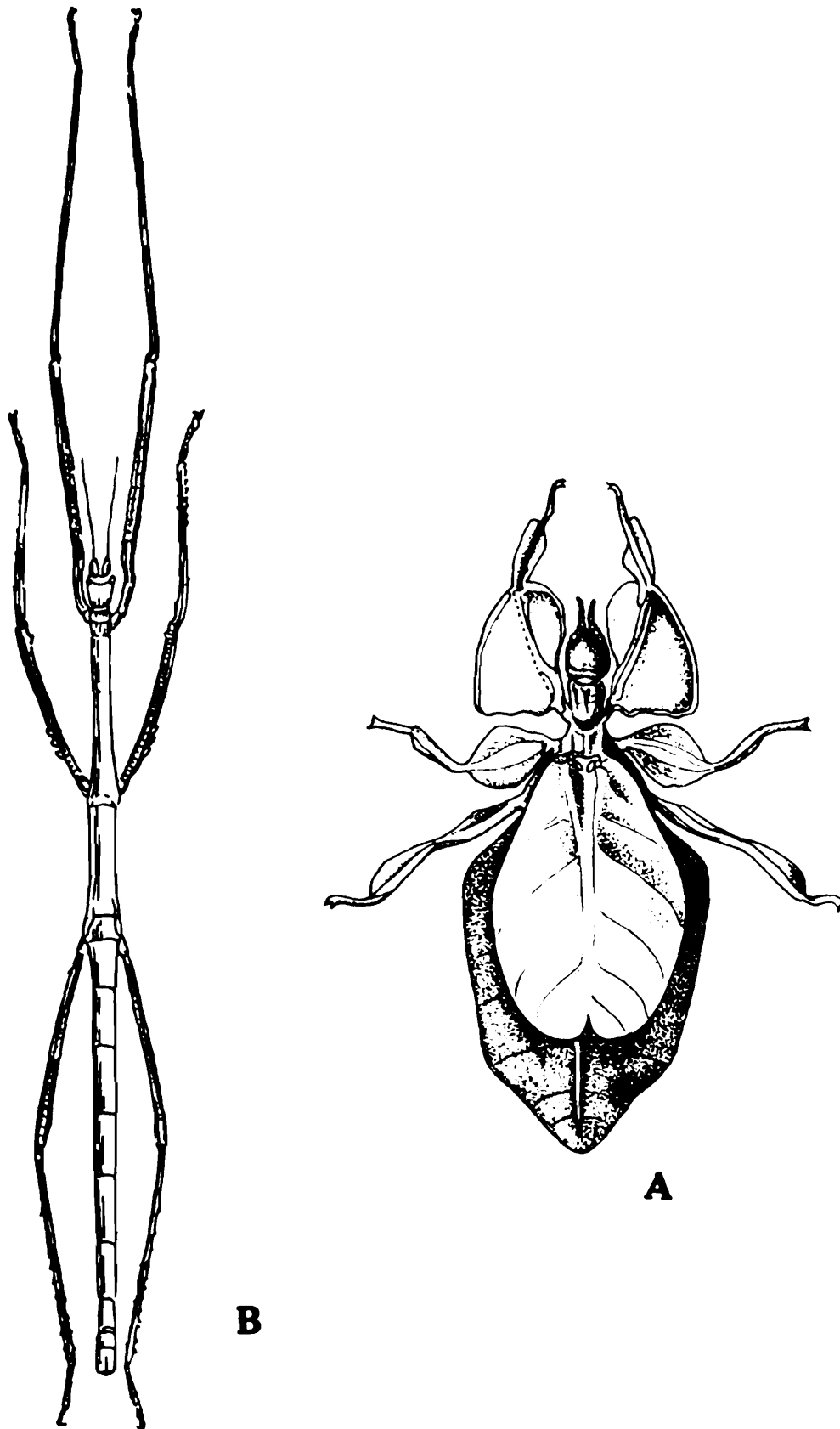

Phasmida (Stick insect and Leaf insect)
A. Leaf Insect; B. Stick Insect

Orthoptera

(Grasshoppers, Crickets, Katydid)

The Order Orthoptera includes familiar and common insects such as grasshoppers, locusts, crickets, mole crickets and grouse locusts. The members of this order occur almost throughout the physiographic zones of India ranging from sea level to the alpine zone in the Himalayas. The order is best represented in the tropical forest belt of the country. It is so far known in India by about 1700 species, and nearly an equal number are yet to be discovered. This order is easily distinguished by its enlarged hindlegs for jumping, and specialised auditory organs. Order Orthoptera includes the families Acrididae (locust and grasshoppers), Tetrigidae (grouse locusts, ground hoppers), Tettigoniidae (long-horned grasshoppers, katydids, bush-crickets), Gryllidae (crickets, tree crickets) and Gryllotalpidae (molecrickets).

Habitat

Majority of orthopterans live in grasses, foliage of shrubs, trees, etc., in temperate and tropical forest zones. They are also found in agricultural fields and vegetation adjoining lakes, river-basins, water-bodies, etc. Some of the species are also attracted to light during night. Most of the orthopteran species are terrestrial but some species of Tetrigoidea, Acridoidea and Grylloidea are also aquatic and semiaquatic. In general, the collecting of orthopterans need experience, practice and knowledge of ecological niches where a particular group occurs.

For example short-horned grasshoppers are mostly found in open grasslands, long-horned grasshoppers in the foliage and shrubs, mole-crickets in burrows and crickets in the foliage, under stones and bark of fallen trees. They are also attracted to light. Besides the above mentioned habitats, they do occur in other habitats also.

Collection

The orthopterans can easily be collected by sweeping over vegetation by means of a butterfly net. Occasionally they can also be collected by handpicking with the help of a pair of forceps. Some of the large species of grasshoppers inhabiting tall bushes are collected with the help of log handle nets or picked up from the ground once they are disturbed and hide in the bushes on the ground. Some species of long-horned grasshoppers, crickets and mole crickets are collected by placing petromax or light trap in the open fields and forests, over a white sheet of paper or muslin cloth. Generally, in Indian conditions, monsoon is the best period of collecting in the plains, and pre and post monsoons in the hilly region. The grasshoppers are generally collected during early hours of the morning, as they are sluggish due to moisture content of the air and can easily be picked up in net as well as by hand.

Preservation

Specimens are generally killed in a killing jar or tube. After killing, the specimens are removed from the bottle within half an hour or so to avoid damage to coloration and are kept in oil paper envelopes. The orthopterans are generally kept in dry

packets but some soft-bodied specimens like crickets may be preserved in 90% ethyl alcohol. Each envelope should contain a temporary label, bearing details about the locality, latitude, longitude and altitude, date of collection, name of collector and if possible, the habitat, with a soft pencil. After return to the field laboratory, the packets must be kept in a cardboard box having a thin layer of cotton. Enough paradichlorobenzene should be kept in the box. The specimen-packets should be arranged loosely in a line. Periodically the packets must be kept in air for drying. The large specimens are preserved by removing the viscera and stuffing with cotton.

Storage and study : The collection brought from the field has to be made ready for study and permanent storage. The orthopteran should be pinned through base of elytra and not through the pronotum. In some cases the elytra and wings are spread on one side only to save space in storage. Smaller specimens such as tetrigid and tridactylids should be mounted on pith or card-board triangles. After pinning and setting, the specimens are to be dried in a drying case for about a week or so. Data labels to be written in India ink on good quality drawing paper. The dried insects with respective labels are now kept in an insect box for study. For pinning, different numbers of pins are used depending upon the size of the specimens. Generally, for orthopterans, pin nos. 3 and 5 are used. The identified collections are permanently stored in insect cabinets, having drawers. The channels or grooves of the drawers are filled with naphthalene powder and covered with a thin layer of cotton. A ball of cotton wool, soaked in a mixture of camphor and carbolic acid in the ratio of 1 : 3 should be pinned at one corner of the drawer. A regular check of drawers for

preservatives is a must for proper upkeep of the insect collection.

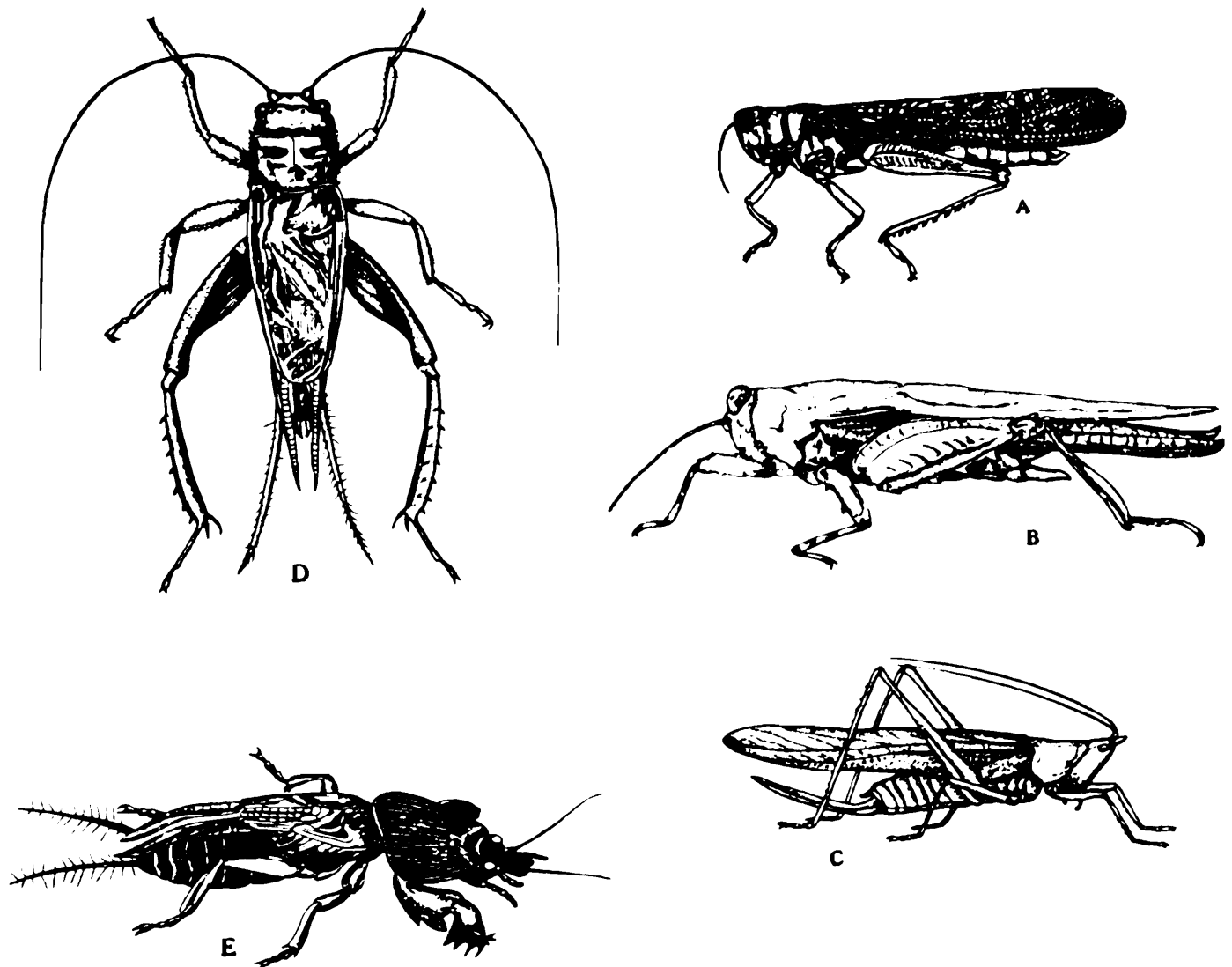

Orthoptera (Grasshoppers, Crickets, Katydid)

A. Locust; B. Grouse locust; C. Bush Cricket; D. Cricket; E. Mole Cricket

Dermaptera

(Earwigs)

Dermaptera are commonly known as Earwigs which attain their maximum development in tropical and subtropical countries. However, a few species are found active even on snow.

Habitat

Commonly occur in dead and decaying matter, under stones and loose bark of logs, stems of standing trees and banana sheath, in flowers, leaf-axis and sometimes even in bird's nest. Generally they avoid day light but a few species are attracted to light in large numbers.

Collection

These can be conveniently collected by picking with the help of forceps and sweeping over wild vegetation.

Preservation

For temporary storage, they are preserved in 90% ethyl alcohol and later transferred on pins. Long preservation in alcohol results in great distention of body segments and loss of general colour. It is advisable to collect a large series containing males and females since intraspecific variations are quite common in the group and the taxonomy of the order is based on males which makes the determination of isolated females difficult.

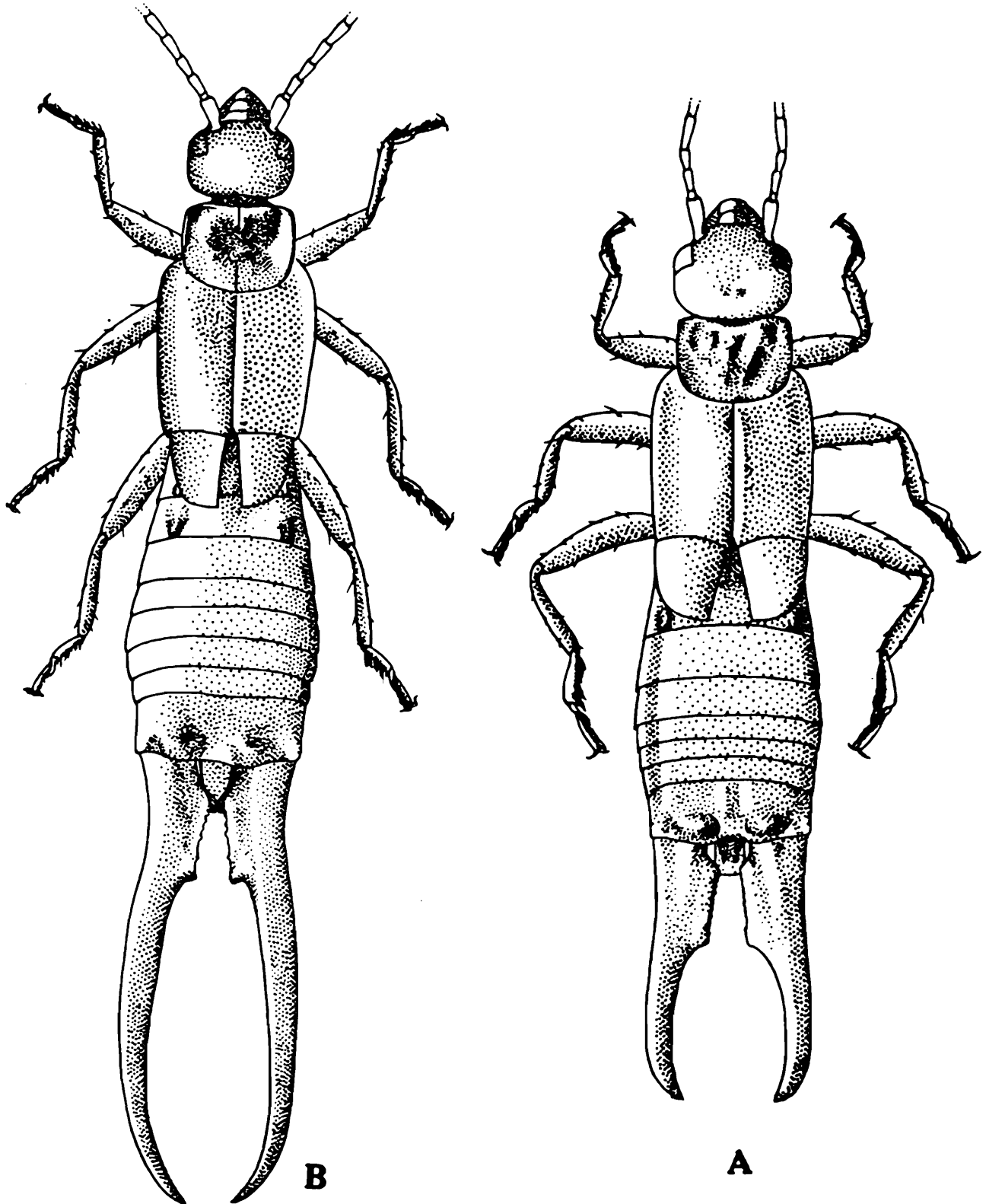

Dermaptera (Earwigs)

A. Brachylabic form; B. Macrolabic form

Embioptera

(Webspinners)

Elongated, soft-bodied, fragile, flattened insects, with biting mouthparts; tarsi 3-segmented, first segment of anterior pair swollen; two pairs of equal sized wing and 2 segmented cerci. Females are apterous.

Habitat

These insects live in small groups in silken tunnels, underneath loose bark of trees, among lichens, on the ground and under stone. The groundnests are often made amongst matted leaves or dry cattle droppings.

Collection

Silken tunnels of these insects should be located and disturbed by pair of forceps after blocking its other end to prevent their escape. An enamel tray can be effectively used to provide base trap, while disturbing the tunnel, wherein embiopterans may fall and can be collected by cotton plug doused or dipped in 70% ethyl alcohol. Special care should be taken to collect samples from each tunnel-system for study.

Preservation

These insects are killed by using 70% ethyl alcohol, either using doused cotton plug or by keeping in a pair of petri dish. Permanent preservation is done in individual vials, filled with alcohol.

Collections made from one tunnel-system should be kept separately in a large jar, filled with 70% ethyl alcohol, and with adequate cotton padding.

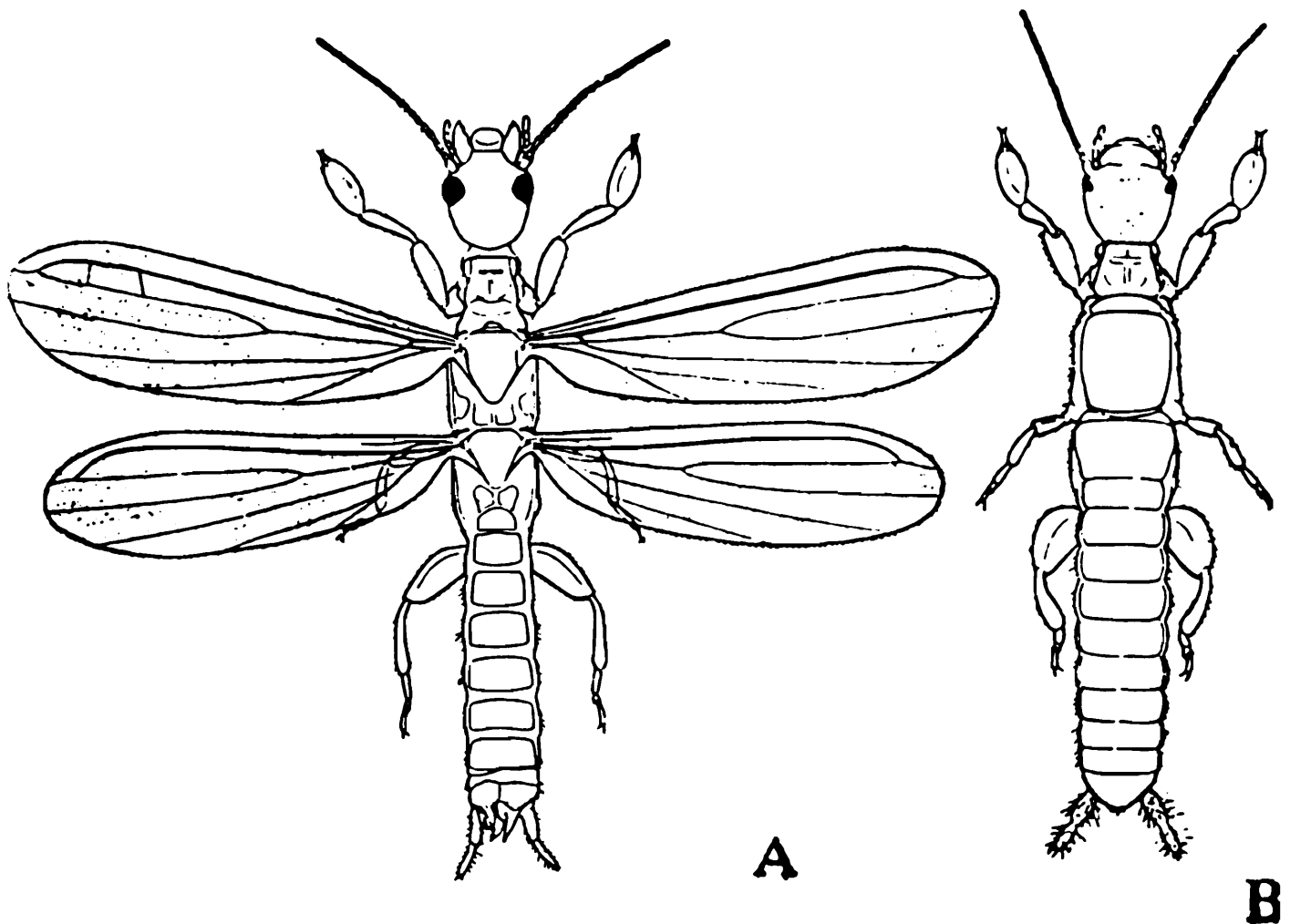

Embloptera (Webspinners)
A. Winged male; B. Wingless female

Dictyoptera

(Cockroaches, Mantids)

Order Dictyoptera is divided into two suborders, *viz.*, Blattaria which includes cockroaches, and Mantodea includes Mantids. These are from medium to large sized insects. Cockroaches are flat insects, with a large prothorax, partly concealing the head. Mantids are predaceous insects, which can be easily recognised by their very mobile head, elongated prothorax and raptorial front legs.

Habitat

Most of the cockroaches are terrestrial although a few live near water. These are abundant in tropical countries and found living in plant refuse or on trees and bushes. A few species occur under the bark of dead and decaying logs. Mantids are generally found among the foliage of plants and are inconspicuous because of their either cryptic coloration or protective resemblance with their surroundings.

Collection

Cockroaches and mantids can be easily collected by hand-picking. However, former may also be collected by turning leaves and beating the vegetation, and the latter by sweeping over the bushes by a net.

Preservation

These insects are generally preserved dry. These may also be preserved in 90% ethyl alcohol.

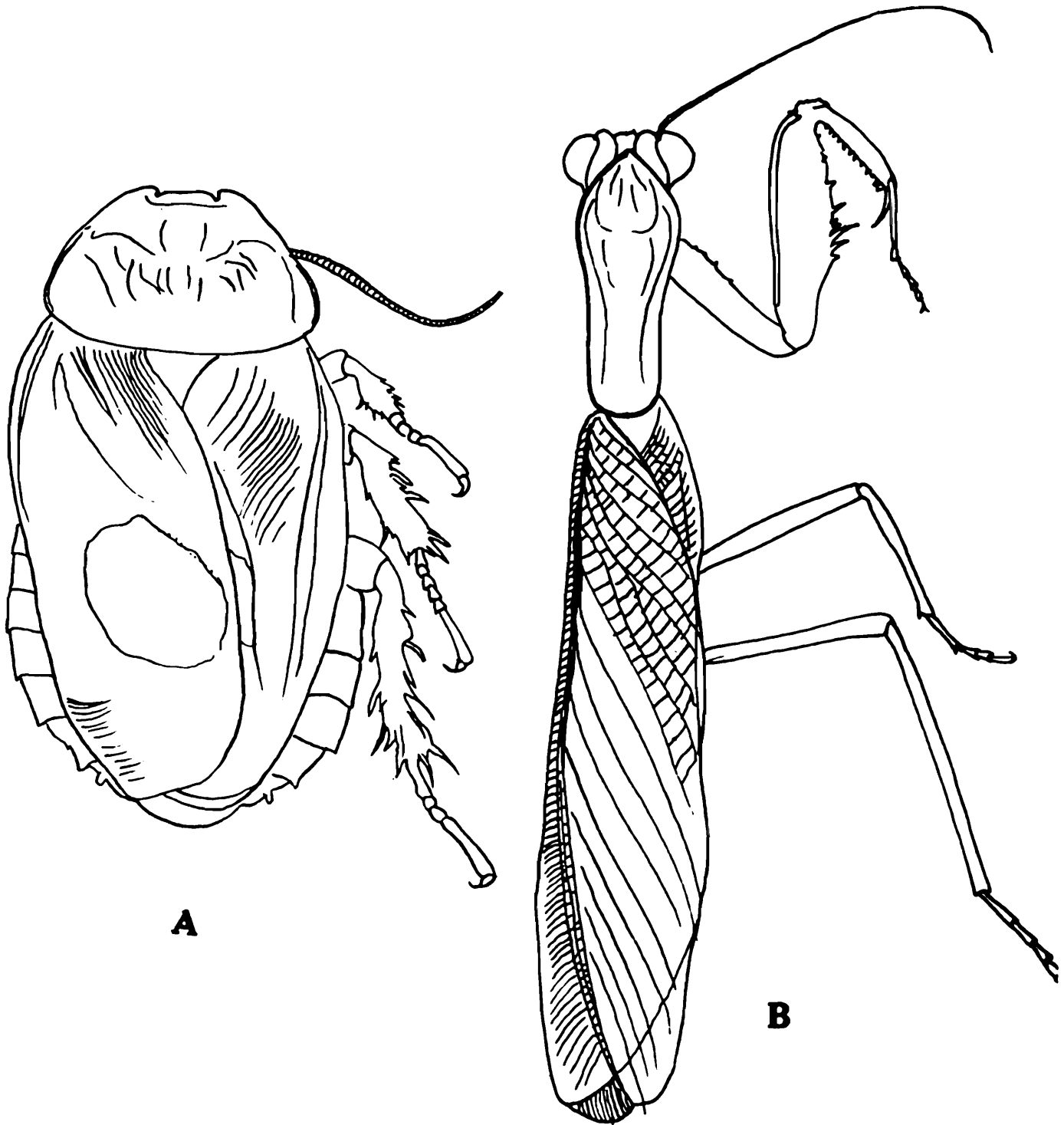

Dictyoptera (Cockroaches, Mantids)
A. Cockroach; B. Mantid

Isoptera

(Termites)

Termites or white ants are small to medium-size social insects, with biting mouth parts. They are highly polymorphic and have three main castes *viz.*, workers, soldiers and alates. Winged forms are often attracted to light.

Habitat

These insects are predominantly tropical and occur in a variety of habitats such as in moist soils, under stones, bark of trees and dead logs. Some species live in wood, making tunnels whereas others are found in large mounds.

Collection

While collecting termites an attempt should be made to collect all the castes. Since the identification of species is mainly based on soldiers special efforts should be made to obtain them. Soldiers can be easily recognised by well developed mandibles, excepting in *Nasutitermes* where jaws are vestigial and head is produced into a pointed horn. Specimens can be easily collected with a fine forceps or a camel hair brush.

Preservation

These insects may be preserved in 90% ethyl alcohol which should be preferably changed after 24 hrs. to avoid dilution.

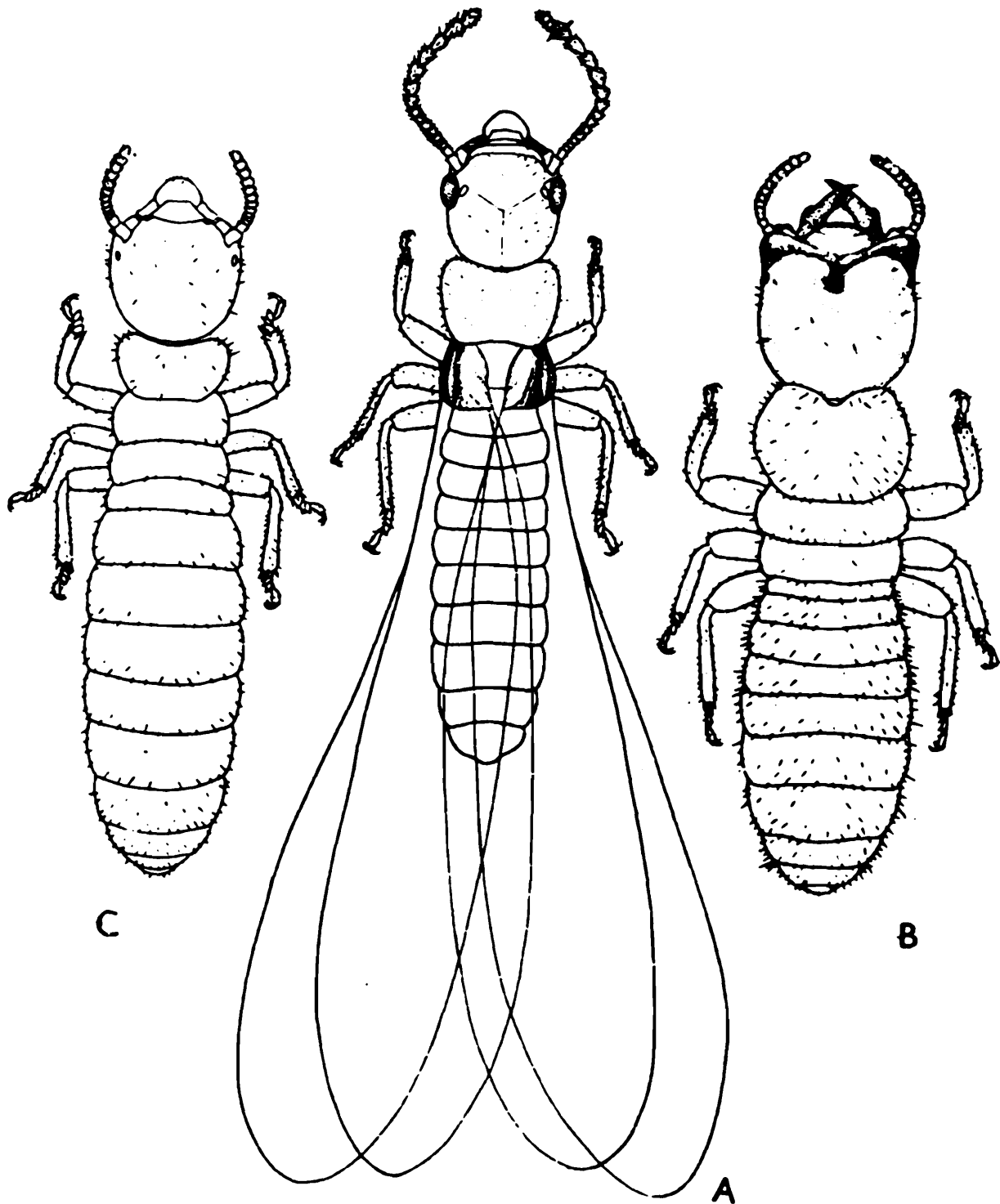

Isoptera (Termites)

A. Imago; B. Soldier; C. Pseudoworker

Zoraptera

(Zorapterans)

Zorapterans are winged or apterous insects, minute (less than 3 mm for apterous) or medium in size (7 mm for winged forms), soft-bodied, with 9-segmented monoliform antennae and short and 1-segmented cerci.

Habitat

These insects usually live in a colony of a few hundred individuals, under dead bark, in rotten wood or in the vicinity of galleries of termites. These are not reported as yet from India but occurs in Sri Lanka and in all other Zoogeographical regions of the world except Palaearctic. Extreme southern part of penninsular India appears to be its probable habitat.

Collection

They can be collected in large numbers by gently scooping or scrapping the bark or wood, putting them in a tray and picking them up with a fine brush dipped in 70% ethyl alcohol or by use of an aspirator.

Preservation

These insects are killed and preserved in 70% ethyl alcohol. Individual tubes should be stored in a larger container filled with 70% ethyl alcohol. Winged forms are preserved dry. They are mounted on paper triangle or pith and stored in an insect cabinet.

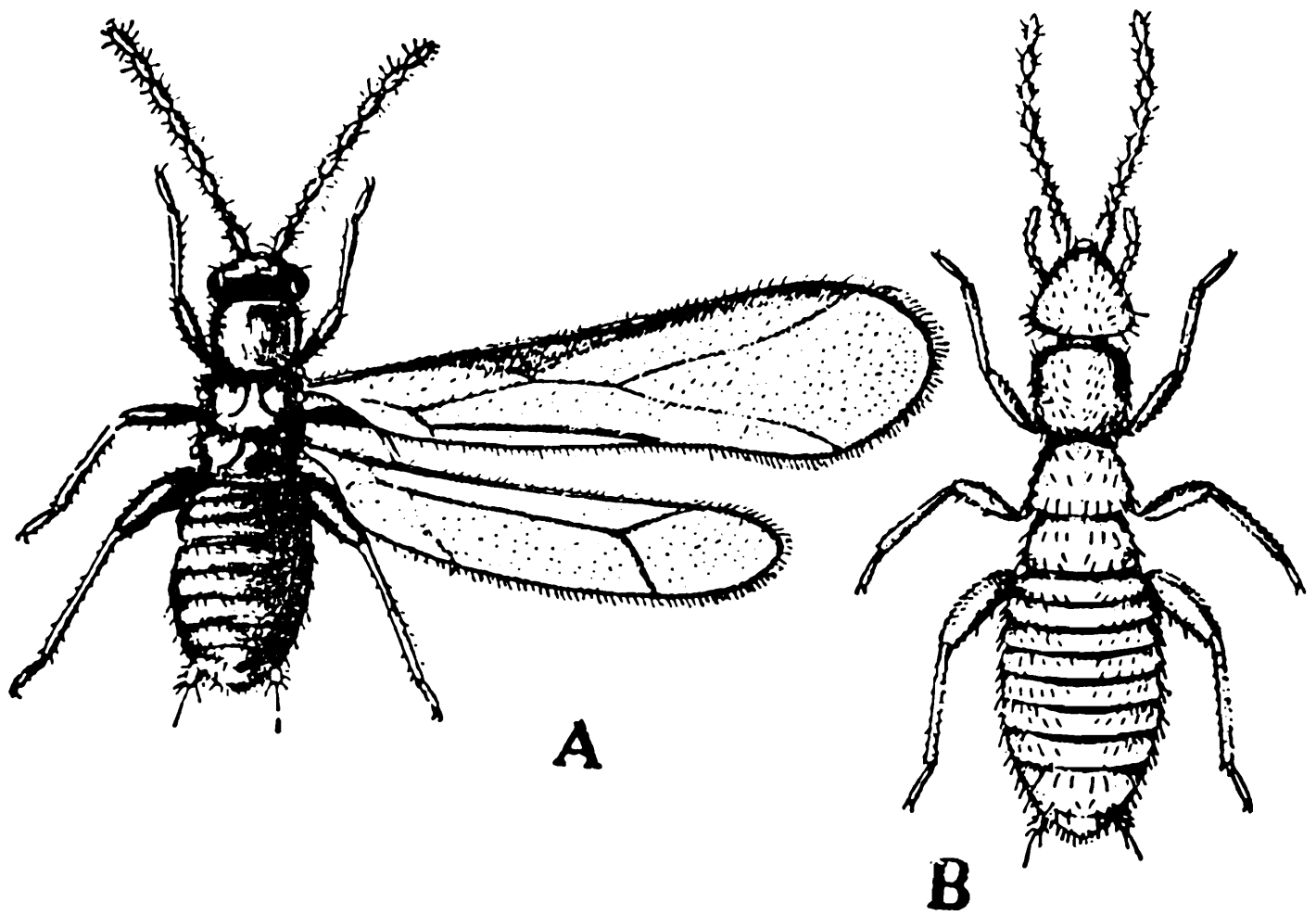

Zoraptera (Zorapterans)
A. Winged male; B. Wingless female

Psocoptera

(Booklice)

Psocopterans are small to medium-sized, soft-bodied, insects. They may be winged or apterous, with long, filiform, 12-25 segmented antennae; mouthparts modified biting-type; wings paired, protectively coloured, with reduced venation; pterostigma present in fore-wings; tarsi 2-3 segmented; cerci absent.

Habitat

These insects are found among foliage in bushes and shrubs; also live in dust in uninhabited rooms and apartments, under loose bark of tree-trunks, book bindings, on weathered palings, walls, in bird and rodent nests and among lichens.

Collection

Larger winged forms can be collected by sweeping with a hand net or by beating vegetation over an enamel tray, and then picking up by a fine brush dipped in alcohol. Smaller forms can be collected by beating vegetation over a tray. Psocopterans hidden in nests can be first tapped into a tray and then picked up. Book lice, which cause extensive damage to documents, specimens, etc, can be collected by jerking them on an enamel tray and picking up by a brush or by an aspirator.

Preservation

Winged forms with scales are killed by exposing them to benzene or cyanide vapour, preserved dry and mounted on cards.

Other non-scaled winged forms are killed and preserved in 70% ethyl alcohol.

Dry mounted forms are kept in insect cabinets, others are kept in individual tubes, stored in bigger containers, both with 70% ethyl alcohol and provided with cotton padding. Whole specimens or wings or bigger forms are permanently mounted on slides and stored in horizontal trays.

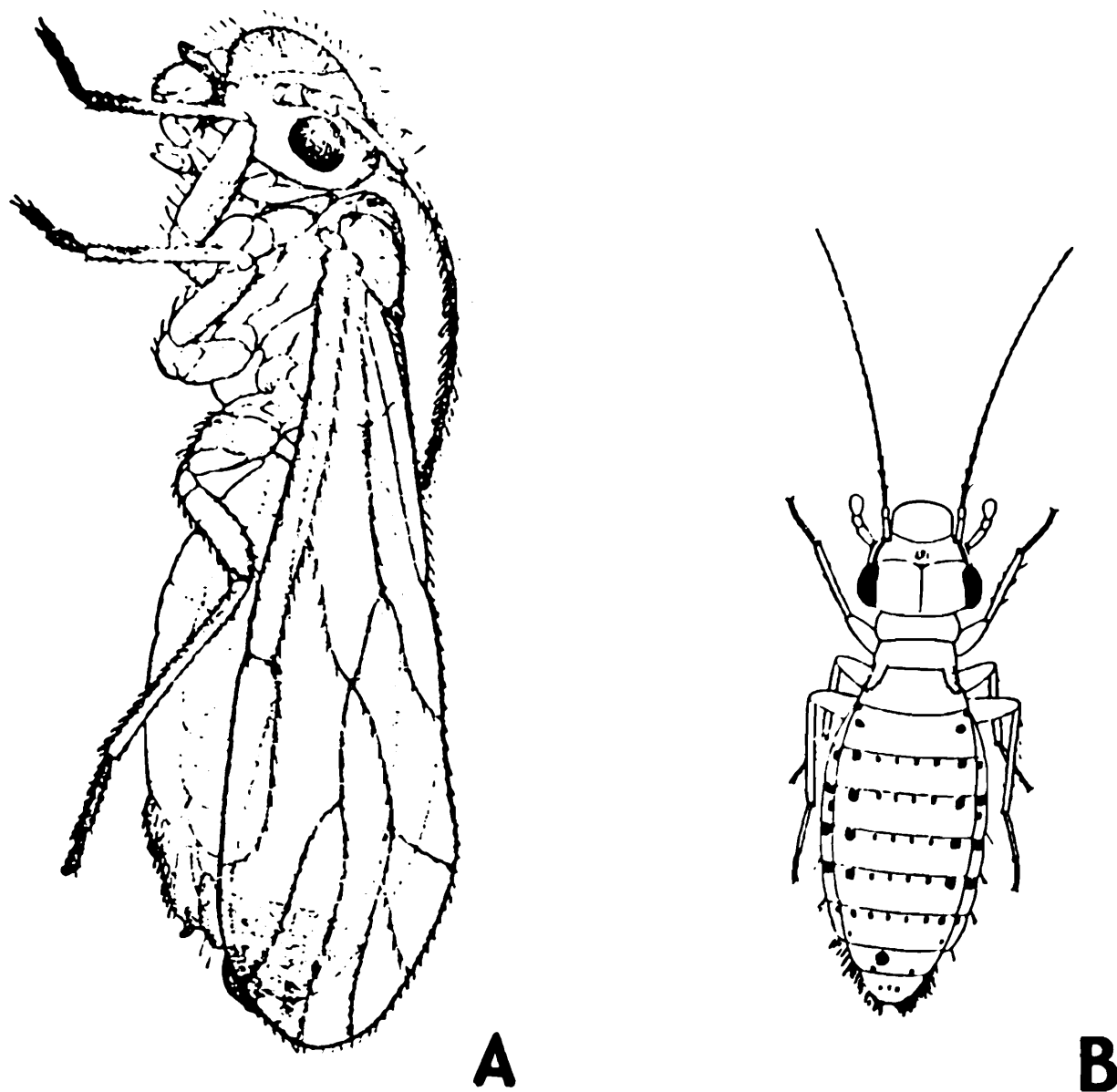

Psocoptera (Booklice)
A. Winged form; B. Wingless form

Phthiraptera

(Chewinglice, Suckinglice)

Order Phthiraptera includes small, wingless, ectoparasitic and host-specific insects popularly known as biting-bird or chewinglice (Mallophaga) and the true or suckinglice (Siphunculata and Anoplura). Former are generally found to infest birds but a few species live on mammals too, and the latter are exclusively mammalian parasites. Chewing lice have biting mouth-parts and feed on plumage, hair and epidermal encrustations whereas the sucking lice possess piercing type of mouth-parts and remain tightly attached to the body of their hosts with specially adapted claws.

Collection

The specimens can be collected by mechanical or chemical methods. In the former methods these are picked up by means of a fine forceps from the host's body, or the body of the host excepting the head (if alive), should be kept inside a polythene bag or fumigation jar with some chemicals preferably chloroform, ether or carbon disulphide which kills the parasite or forces it to leave the body of the host. Therefore, the fumigation container as well as the body of the host should be brushed for obtaining parasites. The chemical extraction is only useful in the case of dead hosts, if the skin is not required to be preserved. The parasites are obtained by dissolving a piece of skin in 5-10% KOH or NaOH and filtering the dissolved contents.

Preservation

These ectoparasites can be preserved in 90% ethyl alcohol or as whole mounts on slides.

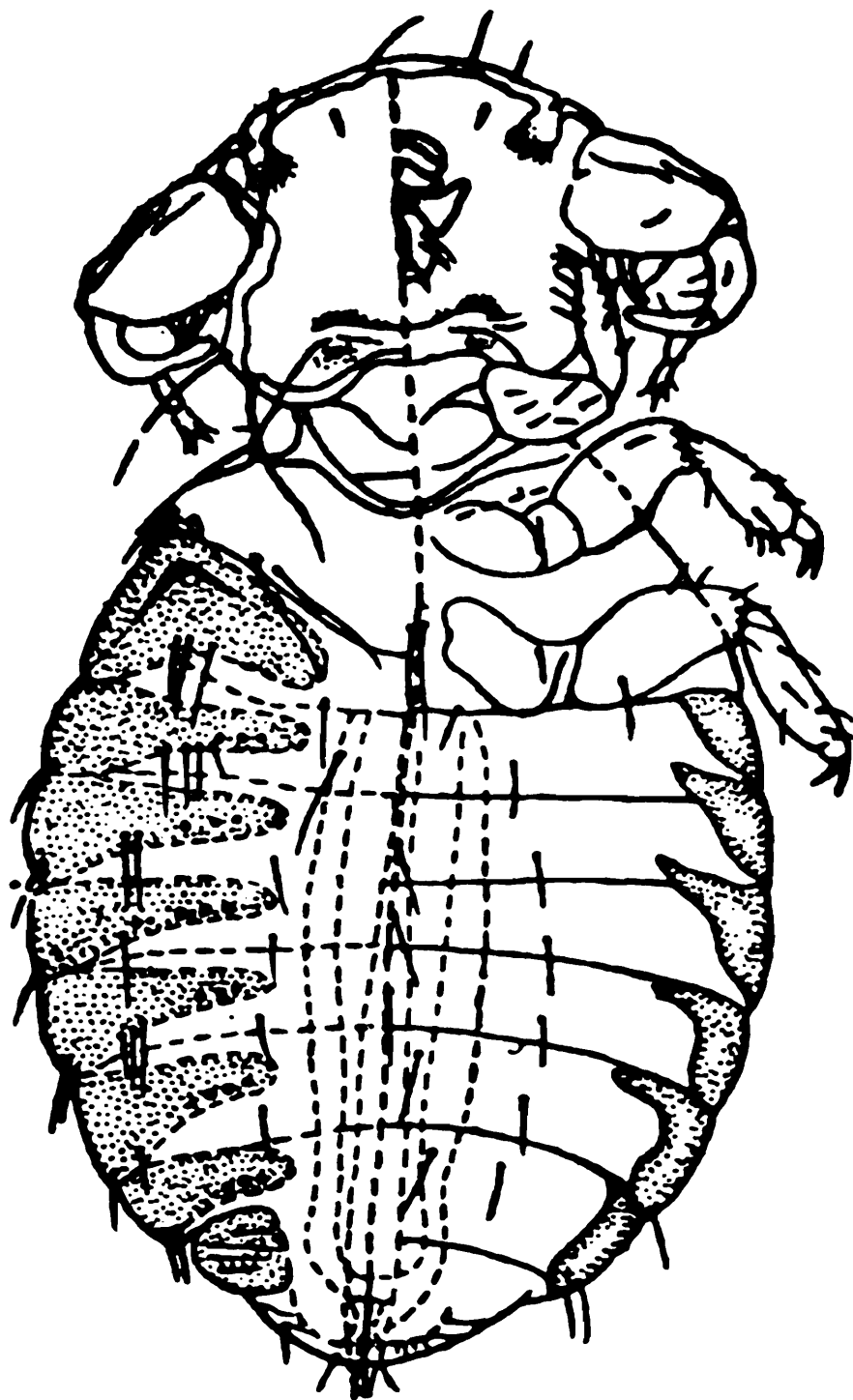

Phthiraptera (Chewinglice, Suckinglice)

A. Male

Hemiptera

(Bugs, Aphids, Coccids, Cicadas, Hoppers)

Hemiptera comprises all types of bugs, cicadas, leaf hoppers, scale insects, etc. It is divided into (i) Heteroptera, in which are included stink and shield bugs, assassin bugs, lace bugs, bed bugs, many families of water bugs, etc., and (ii) Homoptera, in which are included cicadas, plant lice, scale insects, mealy bugs, etc. Hemipterans are small to medium-sized insects, with piercing and sucking type of mouth parts. They usually possess 2 pairs of wings (one pair in male coccids), of which the fore-wings are of harder consistency on basal side in Heteroptera. The presence of scutellum is also characteristic in the latter group of insects. Bugs may be found commonly in all open places, crop fields, gardens, woods, nursery beds and orchards. They are mostly terrestrial, but some are aquatic or semiaquatic. Some bugs are predatory in habit, while others are vectors of virus diseases. Majority of them are, however, sap suckers of crop plants and trees, hence, of agricultural importance.

Heteroptera

Heteroptera are active insects. They move, fly and jump near their host plant. Water bugs are found swimming and living in freshwater pools and streams.

Collection

Bugs can be collected by a sweeping net. Beating of

branches with a stick over a sheet of cloth or rexine (preferably white) will be useful. Picking up of individual specimens from the bark or on lower side of leaves, with the help of forceps, can be tried on such insects which are not very active. The water bugs should be collected by a water net. Often they are found abundant in small tanks, ponds, ditches and on banks of streams. In some cases search below stones and gravel may also be useful.

Preservation

Specimens are killed in an insect killing bottle. They are removed from the bottle as soon as killed, then dried on blotting paper and finally set on pin. If pinning cannot be done immediately, then these are kept in paper envelopes and stored in strong card board boxes. While pinning, the insect pin is to be inserted through the scutellum on a little right side. The antennae, wings and legs should be stretched properly with fine forceps, while setting the insect on pin. Each specimen must have a proper label showing the detailed collection data. It should be of small size, written in Indian ink on cartridge or any other durable thick white paper. Exact location of collecting place, host plant, date of collection and collector's name should be given on the label. All specimens set on pin and labelled, are finally stored in boxes with cork sheet bottom. Powdered naphthalene or para-dichlorobenzene (not both) should be filled in the side furrows of the box, and a cotton ball dipped in a solution of carbolic acid and camphor is also placed in a corner to keep the specimens free from mould, attack of booklice, etc. All aquatic bugs are preserved wet, in 70% ethyl alcohol.

Homoptera

Homopteran insects mostly remain confined to their host plants and are often found in colonies of different sizes. It is essential to indentify the host plant, while collecting these insects.

Leafhoppers : Leafhoppers (Cicadellids or Jassids) jump vigorously. They may be collected by a net. Aspirator with a wide inlet would also be useful. These insects can be preserved dry after killing in cyanide bottle and then mounted on the tip of a triangular card, which is set on a pin, or may be preserved wet in 70% ethyl alcohol.

Aphids : Aphids (greenflies or plantlice) are usually collected with the help of fine brush and preserved in 70% ethyl alcohol. Colour of the body, extent of infestation and associated insects such as ants should be noted at the time of collection. A twig of the host-plant should be taken for herbarium. A good series of specimens, with winged forms, if available, should be taken. A yellow pan water trap has also been used to collect aphids in the open places. Only alate forms get trapped in this way. These insects are immediately transferred from water to alcohol for preservation.

For study, alcohol preserved specimens are cleared and mounted on slides, following usual staining and mounting methods. Clear the material by boiling in 70% alcohol (3 to 5 minutes), then dip in 10% KOH (5 to 10 minutes), and finally keep in a saturated solution of chloral-phenol (3 to 5 minutes) before mounting. For mounting, a medium of 12 gm gum arabic, 20 gm chloral hydrate, 7 ml glycerine and 30 ml distilled water is used.

Coccids : Soft scale insects and mealy bugs can also be collected, preserved wet and mounted in the above manner given for aphids. For armoured scales (Diapsids), however, boiling in 10% KOH or NaOH is recommended. In the case of lac insects, the lac encrustation is dissolved first in rectified spirit. The female body is then again dipped in KOH solution for some minutes to remove the lac dye. Coccids removed from the host plant are preserved in 70% ethyl alcohol. Alcohol preserved material are mounted in the following sequence : Put in 10% KOH solution and heat a little till the body begins to soften and clear; make a small incision in the abdomen on lateral side to tease out internal body contents by gently pressing; wash insects thoroughly in distilled water; put them in acetic acid (2 minutes); stain in 2 to 3 drops of acid fuchsin for 2 to 5 minutes; touch acid if overstained; clear in carboxylol or clove oil for sufficient time and then mount in euperal or canada balsam. Coccid collections are preserved dry also. The leaves or branches, on which the insects have colonised, are cut, dried and kept like herbarium specimens. The dried material can be utilised for slide preparation, when necessary, by keeping the specimens in alcohol for some days. In the case of coccids and aphids, it is recommended that some part of the infested branches (10 to 15 cm long) should be placed in a cellophane bag with adequate labels. Bag should be left open for a day or two to allow the host material to dry to avoid mould contamination. Later, such cellophane bags provided the opportunity to obtain the emerging parasites, as well as adult males, first instar nymphs, and in case of aphids, alate forms.

Whiteflies : Whiteflies (Aleurodids) have powdery wings. They are found on the underside of leaves. Infested portions of

plant are collected and preserved as dry material. The pupae and larvae and their cases are carefully collected as these are required for identification.

Parasitic forms : Ecto-parasitic bugs like the bed bugs are to be preserved wet in 70% ethyl alcohol. The data on host and the location of parasite should be recorded on accompanying labels.

Lighttrap collections : It has been observed that a large number of hemipteran insects are attracted to artificial light at night alongwith other groups of insects. Specially the mercury vapour lamps and yellow light sources of high intensity attract water bugs (Cicadellids, Pentatomids) etc.

Stickytrap collections : At times, sticky agents are applied on cylindrical or flat paper surface and kept at a height of 1 metre in the crop fields. Insects like aphids come in contact with the sticky surface and get entangled. Sticky medium is either castor oil or sesame oil. The insects are removed with the help of a fine brush dipped in alcohol. The specimens are preserved wet in 70% ethyl alcohol. However, this method is not recommended since the antennae, wings, legs or abdomen get stuck to the trap and the insects are often damaged and become unfit for taxonomic study.

Other methods : Besides the use of different types of insect collection nets, e.g. sweeping net, water net, etc., and hand picking methods, some other simple devices can also be used for making collections. Suction trap can be used in field to catch flying insects. Aspirator tubes have been found useful to collect minute and delicate insects. In large colonies of cicadellids, membracids, etc., an aspirator with a wide inlet

makes the collection quick and easy, without inflicting damage to specimens. Such insects can be transferred to insect killing bottles, or may be killed in aspirator tube itself by placing a strip of blotting paper soaked in chloroform or benzene. Then the insects can be preserved and stored as reported above.

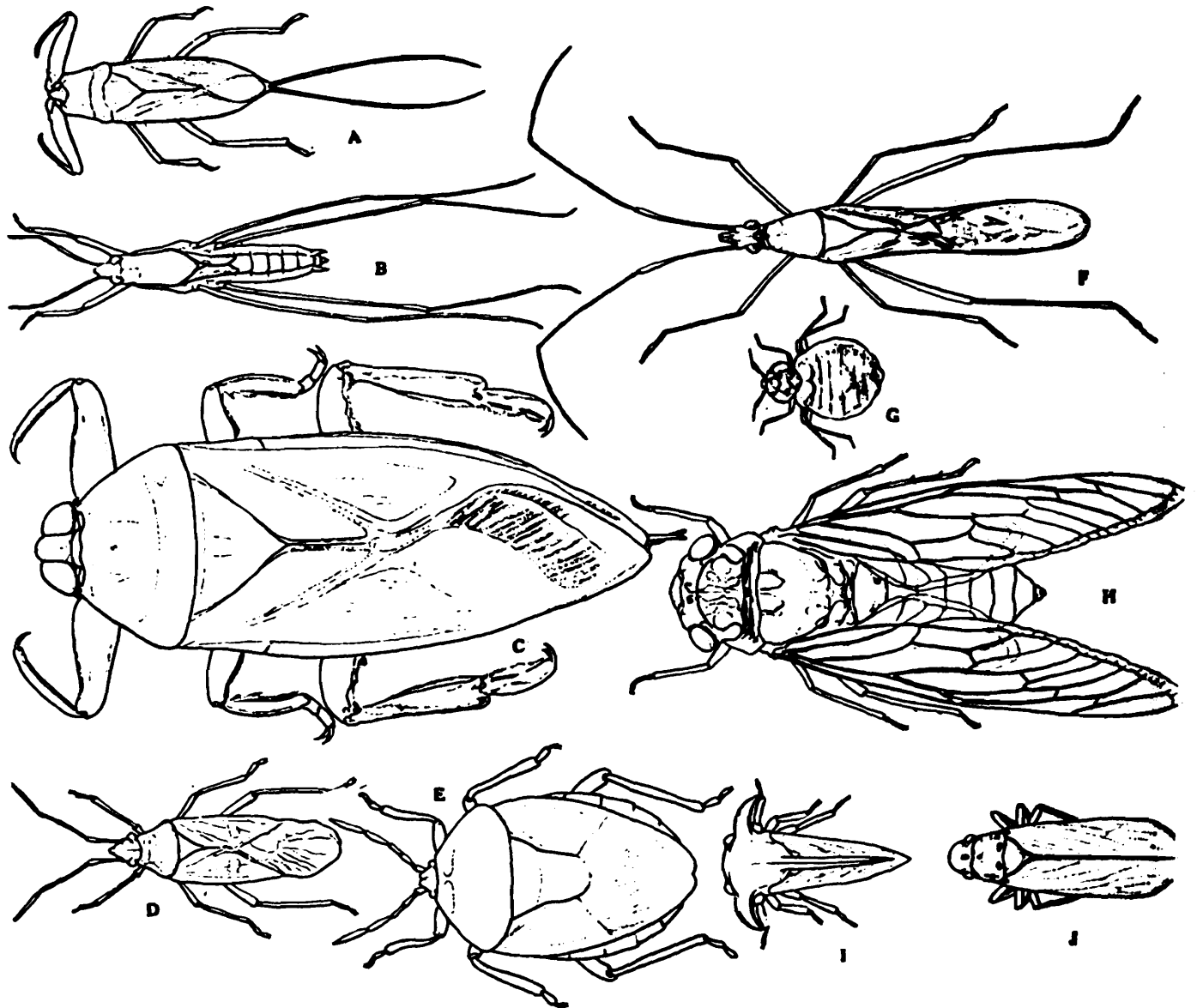

Hemiptera (Bugs, Aphids, Coccids, Cicadas, Hoppers)

A. Water scorpion; B. Water strider; C. Giant Waterbug; D. Red cottonbug; E. Stink bug; F. Gundhi bug; G. Bed bug; H. Cicada; I. Tree hopper; J. Leaf hopper

Thysanoptera

(Thrips)

Thrips are small insects either with two pairs of very narrow and fringed wings or often without wings. They are found on all kinds of plants.

Habitat

The larvae are terrestrial either living freely on plants or in galls.

Collection

These insects may be collected by beating them from flowers, foliage or branches with a stick over a collecting tray or shaken over a sheet of white paper or cloth on the ground. Thrips, caught by sweeping, may be picked up with a camel-hair brush dipped in alcohol or with an aspirator. Berlese funnel is used for the extraction of thrips from soil, leaf-mould and debris.

Preservation

Thrips may be killed and preserved either in 80% ethyl alcohol or in Alcohol – Glycerine – Acetic acid (AGA) mixture. The specimens preserved in 80% ethyl alcohol may be mounted direct on slide but those killed in AGA must be rinsed in alcohol overnight before mounting. Very dark and brittle specimens may be soaked in 5% cold KOH, washed in water and passed through graded series of alcohol and clove oil before final mounting in canada balsam.

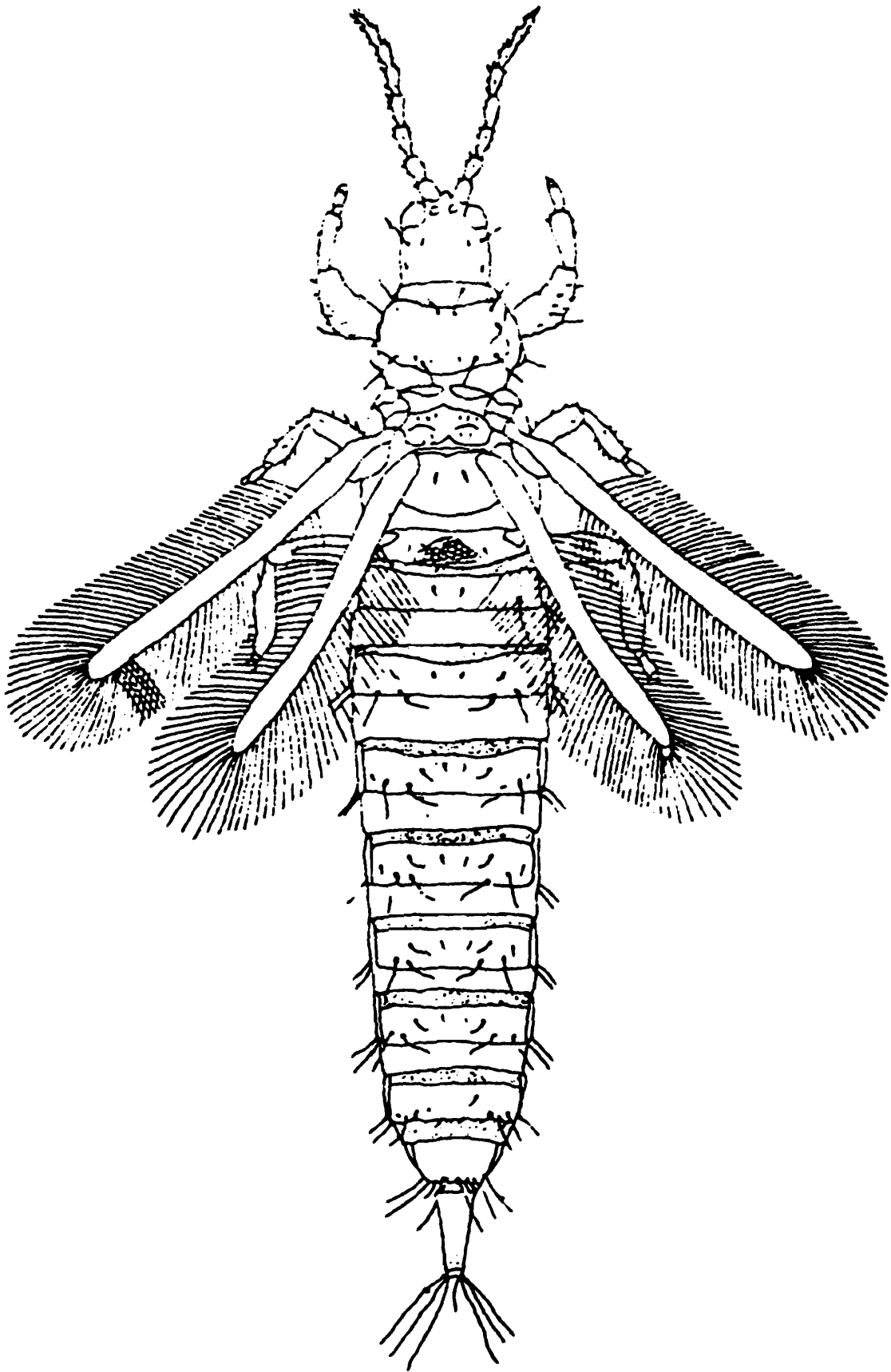

Thysanoptera (Thrips)

Neuroptera

(Lacewings, Antlions, Alderflies, Dobsonflies, Snakeflies)

This order contains a variety of small to large insects which are readily recognised by the fine network of veins of transparent wings and well developed antennae. The wings are held roof-wise over the back, at rest.

Habitat

The adults are generally found on vegetation. The larvae are either aquatic or terrestrial. The terrestrial larvae are found under bark, on vegetation, in sand or dust or even parasitic upon spider's eggs. The larvae, in general, are carnivorous and are predators on aphids, coccids, thrips and other insects.

Collection

The adults may be collected in daytime by sweeping the herbage or vegetation infested with aphids, coccids, thrips, etc.

By beating the bushes, shrubs or branches over a white sheet of paper, cloth or umbrella, a good number of specimens are available. The specimens available either by beating or sweeping may be picked up individually with a forceps or with the help of a brush moistened with alcohol. Aerial netting for the insects in flight during daytime and use of light trap at night are essential for the collection. The aquatic larvae may be collected by aquatic net while the terrestrial ones (under bark, in vegetation or below sand and dust) are collected by hand-picking or with forceps.

Preservation

The adults may be killed in vapour of cyanide, ethyl acetate or benzene and preserved dry in set and pinned condition. 80% ethyl alcohol is used for small and soft-bodied insects. Larvae can be killed in hot water and preserved in 80% ethyl alcohol.

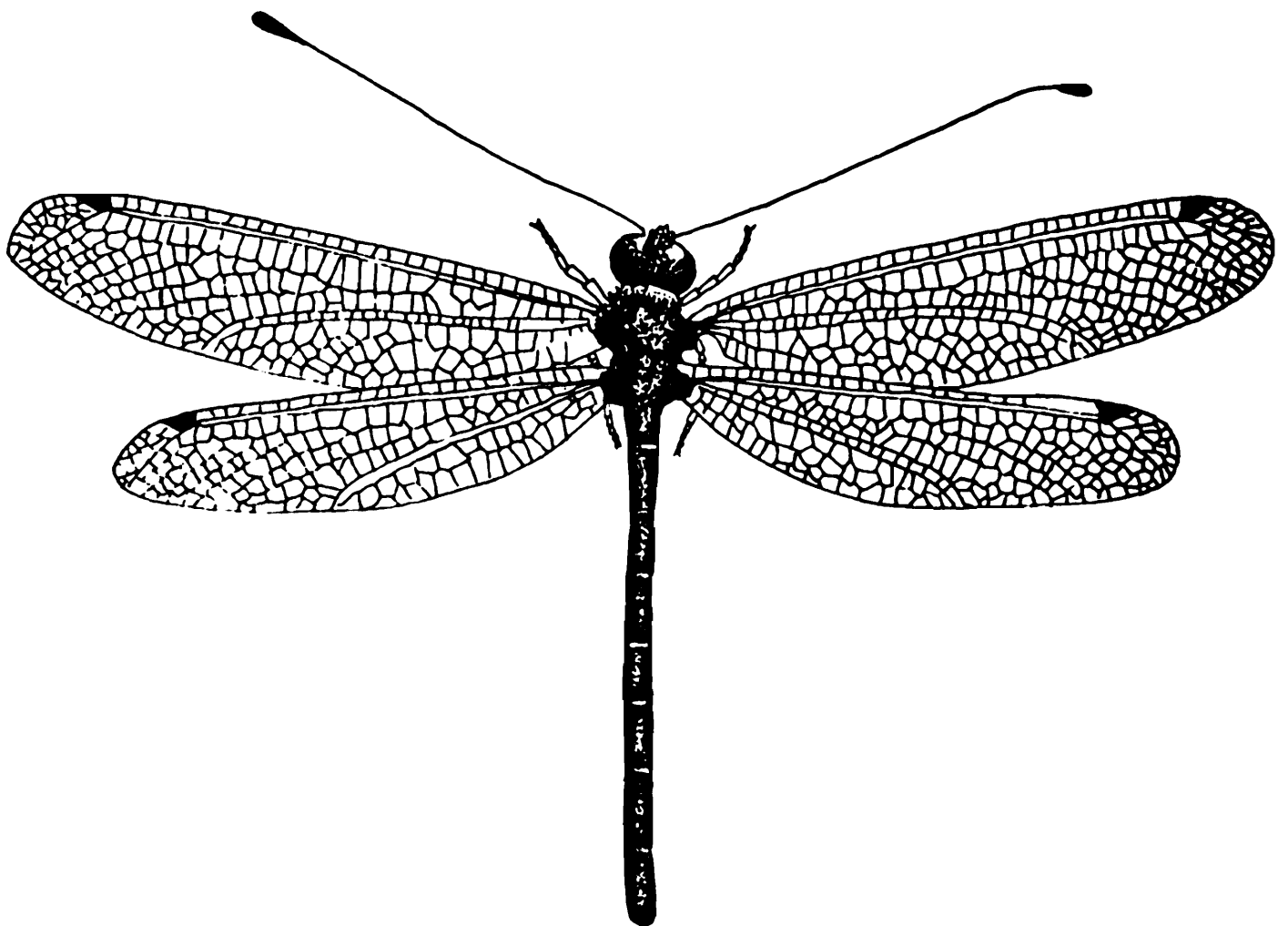

Neuroptera (Lacewings, Antlions)
A. Ascalaphid

Mecoptera

(Scorpionflies)

Mecopterans are slender, soft-bodied small to medium sized insects, with two pairs of similar elongate wings, having a few venation; head is prolonged into a beak, and the abdomen swollen in terminal segment of male and upturned.

Habitat

Mecopterans are generally found at higher altitudes in all types of vegetation, specially beneath foliage, where they wait for small insects to come within their capturing range. Small wingless forms are found under stones and in moss.

Collection

These insects can be collected by gently sweeping or beating the foliage, delicate branches, twigs, leaves, etc. Stones should be gently jerked and moss scrapped off on an enamel tray. Small wingless form can be picked up by a fine brush, dipped in alcohol.

Preservation

Large forms are killed by exposing to benzene or cyanide vapour and preserved dry. Small wingless forms are killed and preserved in 70% ethyl alcohol.

Storage

Dry preserved specimens are either stored in insect packets

and kept in a box containing powdered naphthalene, or are stored in insect cabinets after setting and pinning. Small wingless forms are stored in individual tubes and kept in larger jars, both filled with 70% ethyl alcohol. Sufficient padding is given to prevent breakage of tubes. Each tube should invariably contain a label.



Mecoptera (Scorpionfly)

Lepidoptera

(Butterflies, Moths)

The order Lepidoptera comprises of butterflies and moths, some of them being the most beautiful insects in nature. They are characterised by the presence of scales on fore and hind wings, which come off easily if touched.

Habitat

The butterflies and moths live in diverse ecological conditions and because of the vast variations in the Indian climate and vegetation, a large and diverse number of species of Lepidoptera are available in India.

Papilionidae : Most of the species are fond of visiting and feeding on flowers; some like sitting on damp ground near puddles and others simply love basking in the sun. The flights are variable but rapid and sudden, if disturbed. Predominantly black or dark brown in colour, except the species of *Parnassius* which are predominantly white and are found in high altitudes in the Himalayas.

Pieridae : Most of the species love open places, males preferring sun-shine and females the shaded areas, but not as a rule. Predominantly yellow and white in colour, they settle on damp ground or near puddles either singly or congregating, often in association with a specimen of *Papilionidae*. Flights are usually very slow and sluggish, but fast flying species are also met with in the field, and are also seen settling on flowers.

Danaidae : All species visit flowers or settle on damp ground, including the ground damped with urine. They also have the habit of settling on flowers, over-ripe fruits or congregate on herbs or shrubs. Flights are usually very slow and when caught also feign death. These are among the toughest butterflies and need a very long and persisting pressure at the thorax to be killed. Feigning death also helps them to fly away as soon as these are released from the pressure.

Satyridae : Predominantly brown in colour, the species are weak fliers, with slow, jerky or bouncing movements, rather close to the ground particularly littered with dead and fallen leaves. But there are some species which prefer open meadow and grass lands, abound with small herbs or shrubs. Most of the species do not visit flowers but are attracted to overripe fruits.

Nymphalidae : Nearly all the species visit flowers, being very fond of sun-shine and basking. Flights are fast and are not easily caught. A large number of them are attracted to over-ripe fruits, dung, or fruit dipped in beer. The species are the most beautiful among the butterflies.

Erycinidae : Nearly all are fond of shaded wooded areas, hilly forests and visit areas close to streams or the undergrowth. Flights are very fast, with no liking to settle on flowers.

Lycaenidae : Predominantly blue, but other colours like brown, yellow, metallic green or white are not uncommon. The butterflies are very delicate, mainly very slow fliers and found almost every where, in meadows, open grass lands, shrubs,

particularly along paths and clearings in forests. Majority of the species are fond of visiting flowers.

Hesperiidae : Predominantly the species are dark brown with orange, yellow markings or metallic tinge in some species. Nearly all are very tough and fast fliers and cannot be killed by conventional methods of killing but need to be killed in killing jars. Nearly all the species are small to medium sized, abundant in jungle but also available in open grass lands. Some species are crepuscular or even attracted to light in night. Majority of the species are attracted to flowers and feed on them, others settle on ground or in a shaded area, damp patches or even on bird's droppings. Many species are fond of basking in sun-shine.

Moths : Nearly all moths are nocturnal in habits and are easily caught except some belonging to the families Arctiidae, Zygaenidae, Pyralidae, Sphingidae and Amatidae which among the major families have day flying moths too, and have to be captured by using conventional nets, etc., but killed in killing jars prepared for this purpose.

Collection

Several methods are in practice for collecting moths and butterflies in nature. Some of the important ones are as follows :

In flight or on wings; while settled on damp ground, near puddles or streams, on dry and dead fallen leaves, etc.; by sweeping; by bait; by light trap; collecting immature stages; other specialised methods.

In the first three of the above mentioned methods the collecting is done with the help of a collecting net. It is very important that the collector takes a good look of the collecting site, and the available butterfly fauna, particularly observing the species movement, flight path, whether these are settling or not, and if so whether on ground, flowers, near streams, puddles, etc. The collector should pursue the specimen cautiously. Once within the striking distance, the collector should give a quick stroke of the net over the unsuspecting specimen so as to capture it.

Similarly, when the specimen, either singly or in a group, has settled on ground, one has to move very gently without causing noise or disturbance till one is within easy reach of the specimen/s, holding the net's handle in one hand and the closed end of the net by the other. The mouth of the net must quickly be kept over the specimen/s holding the closed end of the net above it, so that when disturbed, the specimen/s will fly upwards into the net. The net must immediately be dropped sidewise to trap the specimen/s inside. The specimen must immediately be held at thorax, between the thumb and index-finger to stop its fluttering of wings, simultaneously applying light pressure, which will prevent the rubbing off of the scales, and at the same time kill the specimen. The danaids, however, need a long and sustained pressure to kill them and the hesperids being very tough, need to be killed in killing jars.

Several species, while dying, reverse their wings, which must be corrected gently while placing the specimen in the paper envelopes.

Other methods

Bait : Several species of family Danaidae, Satyridae and Nymphalidae are attracted to overripe fruits, or fruits dampened with beer. Some *Euploea* species have a great attraction for settling on a ground dampened with urine, or littered with faecal matter. These can be collected by the method as given above.

Lighttrap : Majority of moths are nocturnal in nature and are attracted to light at night. Several traps have been devised and are in practice. But the most conventional and easy method of collection is to spread a white sheet of cloth on the ground, with a strong source of light placed over it. The white sheet may also be hung, tied between two vertical poles in such a way that it should not hang short of ground but extend forwards over the ground for a few feet so that all those moths which are in the habit of settling on the ground slightly away from the direct source of light, are also caught. The source of light should be placed at such a point that the whole sheet from edge to edge brightly reflects the light.

Once settled, the moths may be collected by placing the mouth of the killing jar over or close to the specimen, which would fly into the jar and would immediately die of suffocation. Once dead, these should immediately be transferred to the paper envelope and should not be exposed to fumes for a longer time, as the fumes effect the colour.

Collecting immature stages : Collecting immature stages, like larvae and pupae, not only provides information on food and feeding habits, behaviour, population studies of their earlier stages, etc., but when reared to adult stage, also provide perfect specimens.

Collecting by specialised methods : Recently, collections have been done by using sex-pheromones extracted from the concerned species, as the pheromones are effective to those species from which these have been extracted.

Preservation

The butterflies and moths are generally killed in killing jars or tubes containing either Potassium or Sodium cyanide, liquid benzene or ethyl acetate. The last two chemicals are quite safe and are widely used these days for killing insects. However, these chemicals need to be recharged frequently as these are highly volatile.

During field surveys the freshly collected specimens are kept in triangular paper envelopes. Their size vary with the size of the specimen to be stored. The envelopes are prepared by thin handmade or translucent oil paper.

Butterflies should preferably be pinned on stainless pins, which are usually of 38 mm length and of various thickness (16, 3, 5, 0, 00, 000, 20) but nos. 3 and 5 are suitable for most of the species, and no. 20 for very small and delicate moths.

For temporary storage in the field, ordinary cardboard boxes may be kept ready, and each day's collection be stored in them. But care should be taken to see that all the packets to be stored have been exposed to sunlight or artificial warmth for some time, to avoid growth of fungus. These boxes should also contain sufficient quantity of powdered naphthalene.

Permanent storage is done in large insect cabinets, with glass-top drawers and grooved sides for filling the powdered naphthalene.

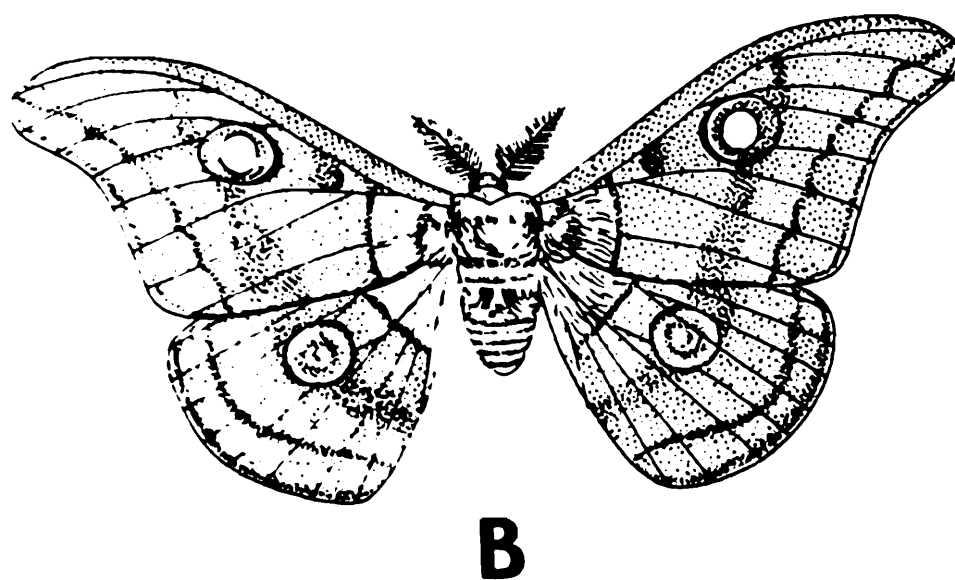
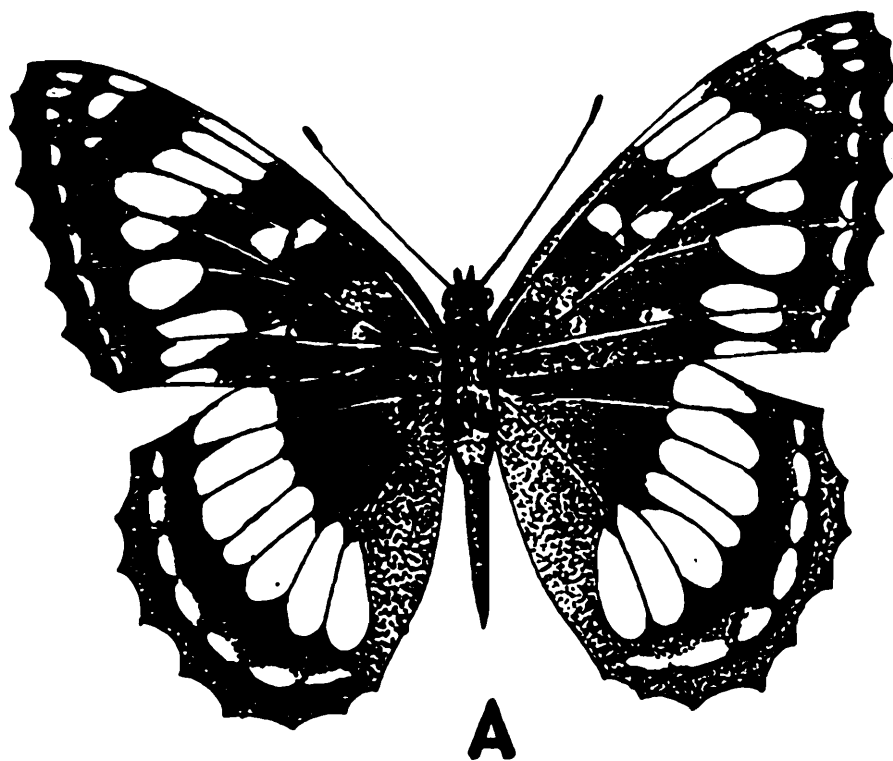

Lepidoptera (Butterflies, Moths)
A. Butterfly; B. Moth

Trichoptera

(Caddisflies)

The adult caddis-fly is moderate-sized, moth-like insects, with hairy wings, reduced mouth parts and well developed palpi.

Habitat

The larvae are aquatic and lie in cases. The cases are formed from sand grains, pebbles, bits of woods, leaves and sometimes silk.

Collection

During the daytime the collection may be made by disturbing the waterside branches of trees with a stick, and when they are in flight they may be collected by aerial netting. Sweeping the vegetation in the vicinity of water source with a net also yields good collection. They may also be collected individually by overturning stones and pebbles alongside streams specially in hilly areas or from nooks and crevices by the aspirator. The application of light traps at night is a good source for collection. Larvae are collected by hand picking from stones in water, by water-net from among aquatic vegetation or by dredging from the bottom.

Preservation

The adults may be killed in cyanide, ethyl acetate or benzene vapour. It may be preserved dry in set and pinned condition or

in 80% ethyl alcohol. The larvae may be killed and preserved in 80% alcohol, with a little ethyl acetate.

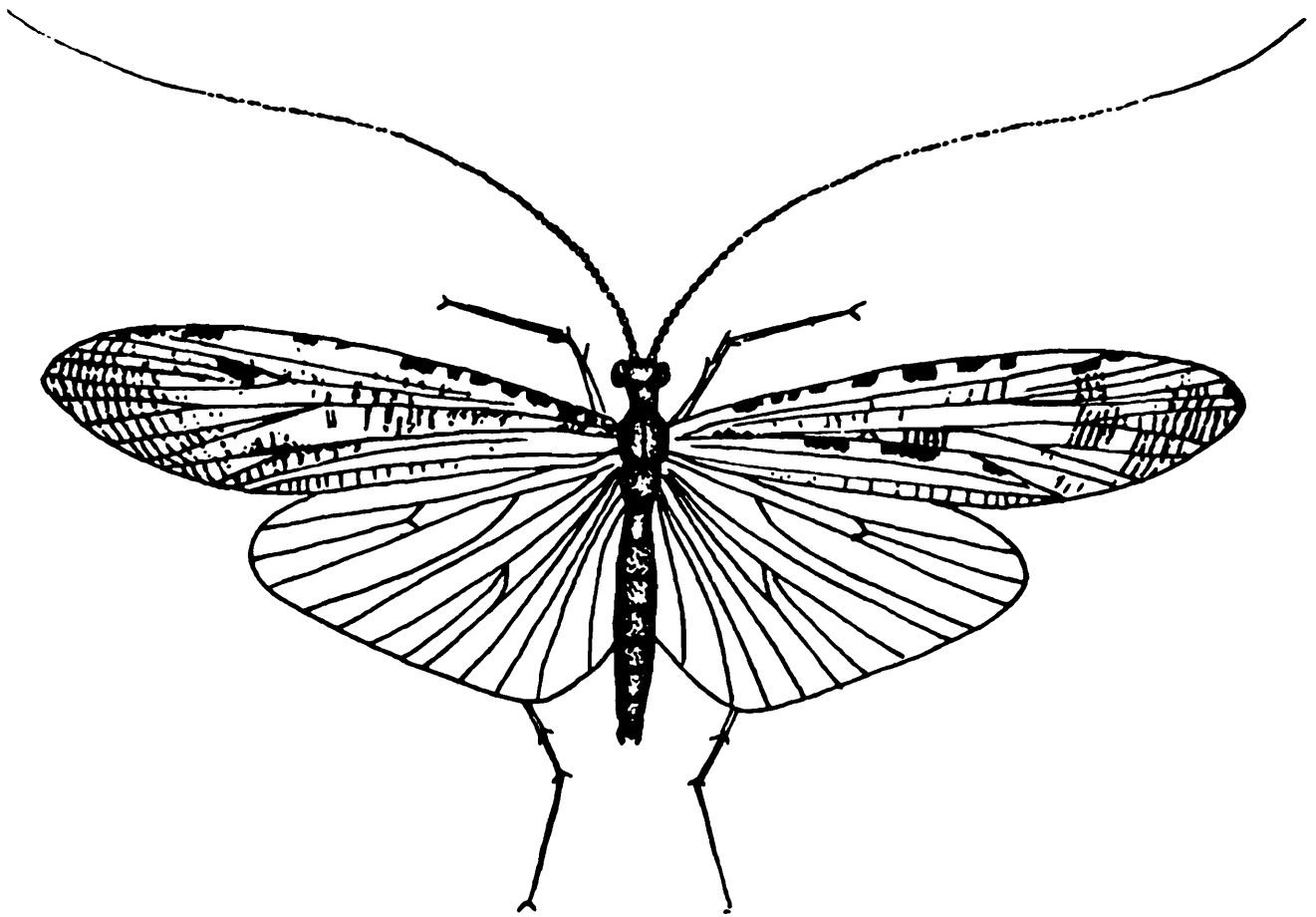

Trichoptera (Caddisfly)

Diptera

(True flies or Twowinged flies)

Diptera is one of the most economically important orders of Insecta and has approximately 120 families. Diptera, as the name implies, are two winged, the hind pair being modified into halteres. They are variable in size, from very small phlebotomids to large sized crane flies. Adult flies are soft bodied with bristles, hair and scales. Since bristles, hair and scales are important in taxonomic studies, care should be taken in the collecting and preservation of specimens.

Habitat

Their abundance is so amazing that they are seen in varied habitats. Some ephydrid (shore fly) larvae develop in seeps of crude petroleum, while some stratiomyid larvae are found in hot springs. Culicid (mosquito) larvae are seen in empty cans filled with rain water and simuliid (black fly) larvae are invariably found attached to stones and twigs in fast flowing streams. Some are beneficial like syrphids (in pollination) and tachinids (parasitic on other insects) while others are harmful like culicids and phlebotomids (vectors) and tephritids and muscids (serious crop pests).

Collection

Adult flies should normally be collected dry. They can be collected by a net and killed in cyanide bottle, benzene or chloroform vapour. The flies must be pinned as early as

possible, either in the field or soon after returning from the field. Flies that are attracted to decaying animals and vegetable matter can be easily collected by bait traps. Small flies like phlebotomids, culicids, etc., can be collected by aspirators. Those whose larvae live in plant tissue can be better collected by placing the host plant or infected part of the host plant in a rearing container till the adults emerge. Similarly, parasitic flies can be reared by keeping the parasitised host in a rearing container. Ectoparasitic pupipara can be individually collected with forceps. Or, if the host is small like a bat, the killed bat can be placed in a polyethylene bag, with its mouth tied by a rubber band and left until the parasites come out. Then the flies can be easily collected.

Preservation

Minute flies like phlebotomids which occur in large numbers can be preserved in 70% ethyl alcohol. Before pinning they are dried by passing through cellosolve (2-ethoxyethanol, ethylene glycol, ethyl ether) and xylol. Care should be taken not to leave the specimens for a longer duration in xylol, since it will make the specimens extremely brittle. Dipterous larvae and pupae are preserved in 70% ethyl alcohol.

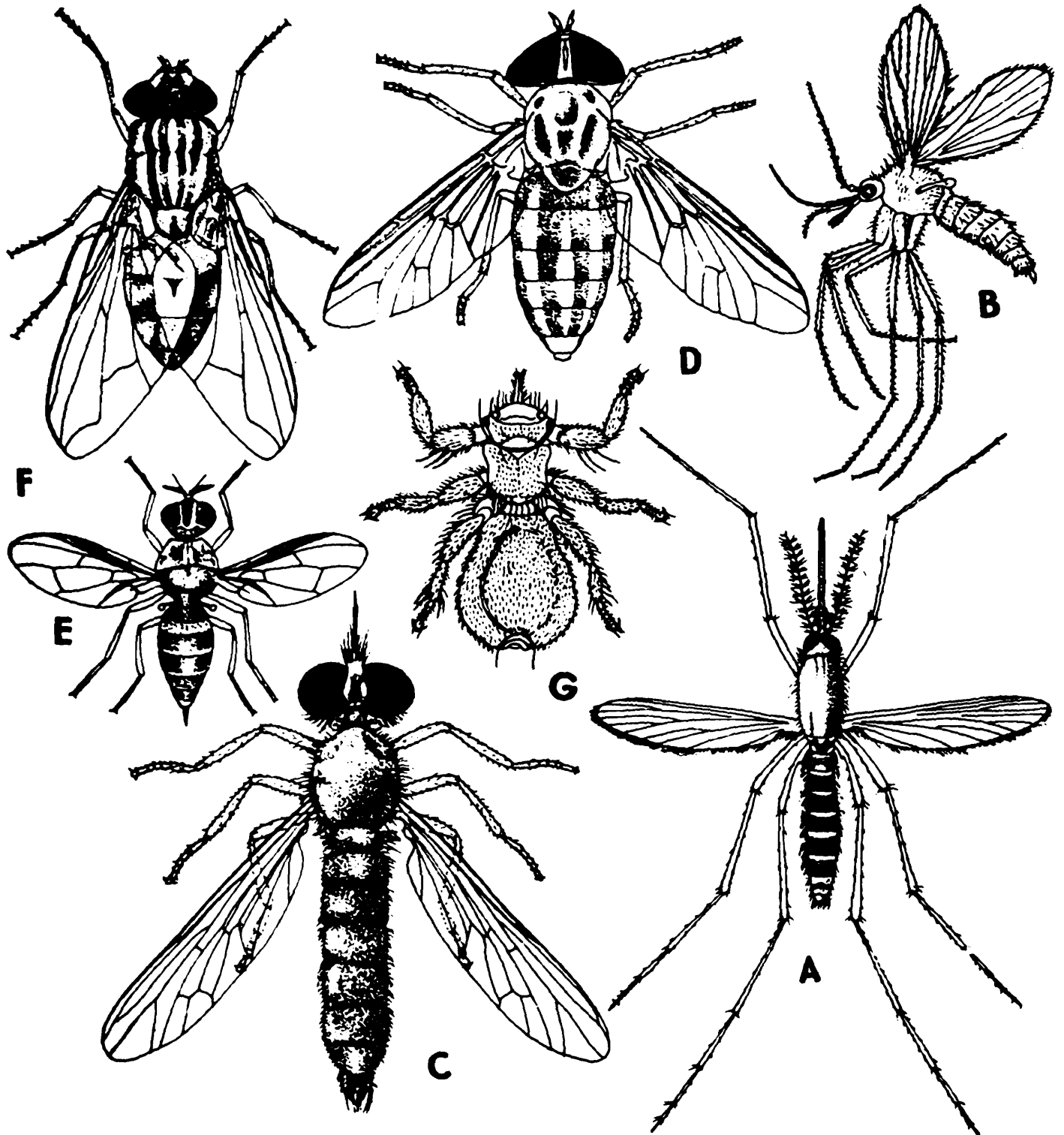

Diptera (Trueflies)

**A. Mosquito; B. Sandfly; C. Robberfly; D. Horsefly; E. Fruitfly;
F. Housefly; G. Forestfly**

Siphonaptera

(Fleas)

Order Siphonaptera includes small, wingless and compressed insects that are ectoparasitic on birds and mammals and are popularly known as fleas.

Collection

Adults can be collected from the body of hosts or their haunts by a fine forceps or by pressing the parasite gently with a cotton swab dipped in chloroform or alcohol which may either kill or make it inactive for picking. Fleas should always be picked up by holding one of the legs with a fine forceps. If the abdomen is unduly pressed during collection or mounting, the receptaculum seminis is likely to be dislodged from its proper position. This may render their identification difficult.

Preservation

Adults may be preserved in 90% ethyl alcohol or as whole mounts on slides.

Hymenoptera

(Wasps, Hornets, Ants, Bees)

Hymenoptera is a large order comprising several species which are beneficial to man. All true social insects, except termites, belong to this order. Most of them are parasites or predators on other insects and the part played by these insects in the biological control of noxious species of insects needs no emphasis. They are efficient plant pollinators and the only honey producers. Fewer pest species are either ants or sawflies.

They are easily distinguished from the true flies (Diptera) by their two pairs of membraneous wings, the hind pair being somewhat smaller. Hind wings are held to the forewings by a row of tiny hooks on the front margin, which catch in a fold of the fore wings. They are strong fliers, though the wings are not very large in proportion to the size of the body. The females of some species are wingless.

The mouthparts are of biting type, but are variously modified, often with a proboscis for lapping or sucking liquid food. The first abdominal segment is fused to the last thoracic segment, but the second (except in sawflies and their close relatives) is much constricted into a pedicel, so that body has 3 distinct regions. Development is complex, larva is usually legless, pupa is sometimes enclosed in a silken cocoon.

Insects of only this order have true sting. The sting is usually the modified ovipositor of the female; males are without a sting.

Collection

The collecting of hymenopterous insects is difficult because of their swift flying habit and the fear of being stung. The hymenopterans are collected by traditional method, besides certain special techniques.

Handpicking : There are several species which are wingless and are collected by hand, such as ants, and females of velvet ants (Mutillids), which crawl on ground foliage. The female mutillids are also caught in sweeping nets when they are being carried from one place to another by their winged males. To facilitate their identification, both wingless and winged forms should be collected.

Sweeping : Sweeping foliage, thick under-growth, grasses, etc. yields a large number and variety of hymenopterans.

Some tender bodied insects, such as sawflies (Tenthredinidae) and horntails (Siricidae) are best collected individually in nets. The members of these families and a few more are outstanding pests (defoliators) of coniferous trees. Other hard bodied insects which are usually collected by sweeping include some aculeata and most of the parasitic Hymenoptera. Several varieties of social Hymenoptera are caught by sweeping but these can also be collected by locating their nests.

Lighttrap : Several nocturnal species are attracted to light and can easily be caught by hand.

Malaise trap : In certain season when insect population is high, collecting can be done by placing Malaise traps. All

types of flying insects when trapped fall in a bottle containing a suitable preservative. These bottle are changed at regular intervals.

Rearing methods : A large number of parasitic hymenopterans are collected by rearing the pests in the laboratories. The specimens collected by rearing are considered best for identification, as they provide information on insect-host and plant host relationship, their life history, etc.

Berlese funnel : Several species of wingless hymenopterans such as ants and velvet ants inhabit leaf litter or subsoil. They can be extracted by Berlese funnel.

Preservation

The specimens may be killed by exposure to cyanide or benzene vapour and preserved in 90% ethyl alcohol. Specimens for detailed study are preserved dry. After bringing the specimens from the field, they are relaxed in the relaxing chambers and when soft they are pinned on good quality entomological pins. Most hymenopterans have membranous wings. Their wings need not be spread horizontally, but spread vertically, in this way they occupy less space in the storing drawers.

Smaller specimens are mounted on small triangular cards with a water soluble adhesive, so that they can be removed if necessary. After pinning, each specimen is provided with the information regarding locality, date of collection, name of collector and any other information of taxonomic importance on a label.

Certain species of Hymenoptera, which are usually collected in large numbers, such as ants, bees, wasps, etc. are temporarily preserved and stored in 90% ethyl alcohol. The only disadvantage of keeping the material in alcohol is that their body integument in some cases gets discolored.

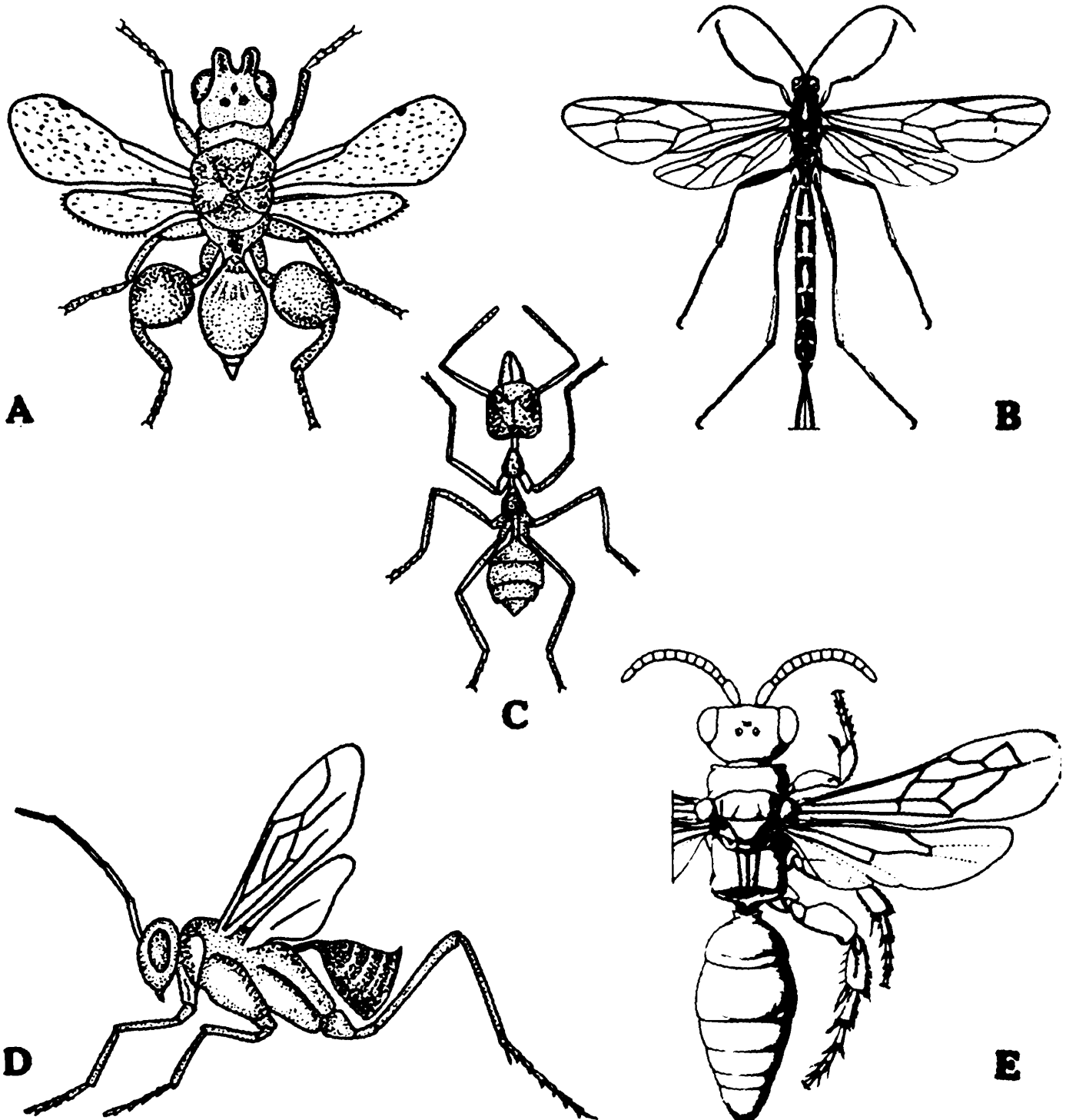

Hymenoptera (Wasps, Hornets, Ants, Bees)
A. Chalcid; B. Ichneumonid; C. Ant; D. Evaniid; E. Tiphid

Coleoptera

(Beetles)

Members of the order Coleoptera are commonly known as beetles which evolved in the Permian period of geologic era and form by far the largest order of insect in the animal kingdom. The group contains nearly a quarter of a million known species, which is equivalent to about 40% of the insect fauna of the world. India being situated in the tropics is well known for her richness of coleopterous fauna. The dense and evergreen forests of Northeast India and Nilgiri hills as also the Vindhyachal and Satpura ranges provide enormous variety of habitats and innumerable variety of beetles. They are predominant insects of the present epoch and their adaptability and the structural modifications are the main cause of their dominance in the animal world. There is no other order of insects which can invade the land, air and water in an almost equal degree.

Approximately the total described species of Coleoptera in the world is 3,50,000 of which, less than 10% are known from India. Our knowledge of Indian Coleoptera in general, is still based on Junk's Coleopterous Catalogue (1910-1940) and the 'Fauna of British India' volumes (1906-1939). Junk's Coleopterous Catalogue has included 133 families, and Crowson (1955) included 157 families. The present authors feel that coleopterans can be classified into 185 families.

In the order Coleoptera there are 8 major families which include more than 10,000 known species. These are : Carabidae

(18,259), Staphylinidae (19,909), Scarabaeidae (12,200), Buprestidae (11,391), Tenebrionidae (14,641), Cerambycidae (14,085), Chrysomelidae (18,937) and Curculionidae (34,500). In India, beetle fauna of above families are abundant and extremely diverse.

Habitat

The habits of different types of beetles are so varied or diversified that they can invade every type of environment suitable for their existence. The members of 12 families are truly aquatic and chiefly found in ponds, lakes, rivers, drains and ditches, while many other families have aquatic and semi-aquatic representatives and several species are littoral and daily submerged by the tides.

They may be herbivorous (Platypodiidae and few Chrysomelidae), putrivoracious (many Histeridae, Silphidae) or carnivorous (many Carabidae, the predaceous Coccinellidae). Many of them are stored grain pests (Cucujidae, Silvanidae, Tenebrionidae, Curculionidae, Dermestidae, Bostrychidae, Bruchidae, Anobiidae, Nitidulidae, Trogositidae etc. causing serious damage to cereals, cloths, fur, wool, silk, pulses, spices, drugs, tobacco, furniture, etc.); also forest pests (Cerambycidae, Buprestidae, Curculionidae, Bostrychidae, Scolytidae etc.) may be crop pests (Chrysomelidae, Curculionidae, Coccinellidae etc.); may be fruit garden and orchard pests (Scarabaeidae, Curculionidae and Cerambycidae); many of them also infest the roots (Melolonthinae) and also destroy young seedlings (grubs of rhinoceros beetle, *Oryctes* sp.) and many of them are defoliators (Chrysomelidae), damage

seeds (Bruchidae, Curculionidae) and leaf rollers (Curculionidae). The different species of this group also attack and destroy tree growth and effect different parts of the tree (roots, stem, branches, young twigs, buds, leaves, inflorescence, etc); besides, many of them are predators.

Collection

Beetles can be collected by hand picking; sweeping; beating bushes, foliage, branches and herbs; by beating haystack after keeping the tray underneath; lifting the bark by butcher knife; using pitfall trap, light trap, bait traps and Berlese funnel; within the flower; from stored materials; from termite, ant and bird nests and from crop fields.

Preservation

Beetles can be killed by hot water, by exposing to vapour of chloroform, benzene, ethyl acetate or K or Na Cyanide, and by 70% ethyl alcohol. 70% alcohol is good for larvae and microcoleoptera.

Beetles can be preserved both in dry and wet conditions. For dry preservation, after killing the beetles in a killing jar having ethyl acetate, they are usually relaxed and mounted either on cards or pinned and kept in dry chamber for a few days. Finally the pinned beetles are shifted to permanent wooden cabinets, having a ball dipped in a solution made up of camphor and carbolic acid (3:1) and naphthelene surrounding the boundaries. This will protect the insects from any fungus infection. For wet preservation, beetles are preserved in 70% ethyl alcohol. Soft-bodied insects are preserved in sawdust, with a few drops of ethyl acetate.

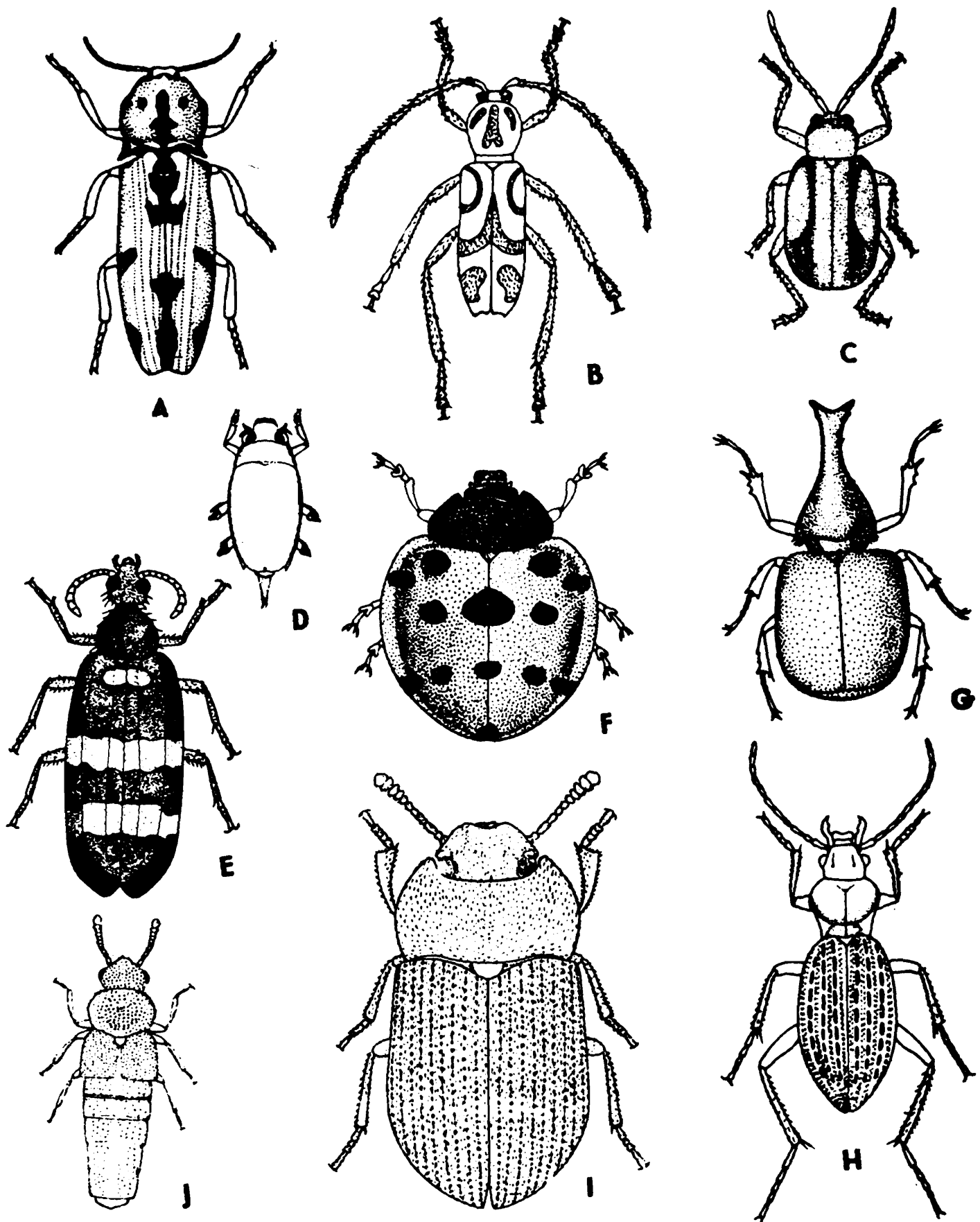

Coleoptera (Beetles)

A. Click beetle; B. Longhorn beetle; C. Leaf beetle; D. Whirligig beetle;
 E. Blister beetle; F. Ladybird beetle; G. Dung beetle; H. Rove beetle;
 I. Darkling beetle; J. Ground beetle

Chief habitats of major beetle families :

- | | |
|---|--|
| 1. Under stone | : Carabidae, Staphylinidae, Byrrhidae |
| 2. Under bark | : Carabidae, Staphylinidae, Histeridae, Niponidae, Curculionidae, Silvanidae, Cucujidae, Brenthidae, Erotylidae, Colydiidae, Othniidae, etc. |
| 3. Leaf litter | : Carabidae, Pselaphidae |
| 4. Aquatic : | |
| (a) Ponds, lakes, quiet streams | : Dytiscidae, Haliplidae |
| (b) Muddy ponds | : Hygrobiidae |
| (c) Mountain streams | : Amphizoidae |
| (d) Stagnant and flowing water | : Gyrinidae |
| (e) Bottom of streams | : Dryopidae |
| (f) Margin of streams, sand, mud | : Georyssidae |
| (g) Brackish and stagnant water | : Hydrophilidae |
| 5. Galleries in the mud bank, along streams | : Heteroceridae |
| 6. Rotten wood | : Rhysodidae, Paussidae, Ptiliidae, Rhipiceridae, Endomychidae, Cioidae, Rhiphiphoridae |
| 7. Carrion | : Staphylinidae, Silphidae, Histeridae |
| 8. Haystacks | : Staphylinidae, Histeridae, Curculionidae, Silvanidae, Cryptophagidae |
| 9. Decaying vegetable matter | : Staphylinidae, Silphidae, Erotylidae |
| 10. Pollen of flower | : Nitidulidae |
| 11. Leaf mould | : Scydmaenidae |
| 12. Tree-holes | : Cerambycidae |
| 13. Moss | : Scydmaenidae |
| 14. Ant nests | : Scydmaenidae, Leiodidae |

- | | |
|--|--|
| 15. Rotten plant material | : Clambidae |
| 16. Fungi | : Leioididae, Scaphidiidae,
Erotylidae |
| 17. Excrements | : Scarabacidae, Histeridae |
| 18. Plants | : Lycidae, Buprestidae |
| 19. Foliage | : Chrysomelidae,
Curculionidae, Lampyridae,
Cantharidae, Rhagophtha-
lmidae, Elateridae, Bupres-
tidae, Coccinellidae,
Anthicidae |
| 20. Grass | : Cantharidae, Phalacridae |
| 21. Bushes & flowers in the
vicinity of water | : Dascillidae, Elateridae,
Meloidae |
| 22. Leaf bases, hollow of trees | : Helodidae |
| 23. Woody plants, dead twigs and
branches | : Cleridae |
| 24. Decaying wood | : Lymexylonidae |
| 25. Stored products | : Tenebrionidae, Curculi-
onidae, Anobiidae,
Ptinidae, Dermestidae,
Bostrychidae, etc. |
| 26. Furniture & drugs | : Anobiidae |
| 27. Wool, dried animal substances | : Dermestidae |
| 28. Wood borer | : Bostrychidae; Ceramby-
cidae, Scolytidae,
Platypodiidae, etc. |
| 29. Under bark of dead trees | : Melasidae |
| 30. Roots of grasses | : Throscidae |
| 31. Oozing sap of trees | : Histeridae, Nosodendridae,
Syntelidae |
| 32. Fungus infested wood | : Rhizophagidae |
| 33. Garden refuse | : Biphyllidae |
| 34. Bee's nest, male cone of cycad | : Nitidulidae, Languriidae |
| 35. Fungusy bark | : Mycetophagidae,
Endomychidae |

- | | |
|---|--|
| 36. Flower | : Malachidae, Cleridae,
Phalacridae, Lathridiidae,
Coccinellidae, Oedemeridae,
Anthicidae |
| 37. Feed on mycetoza | : Nitidulidae, Sphindidae |
| 38. Shrubs | : Pyrochoridae |
| 39. Bushes | : Meloidae |
| 40. Umbelliferous flowers | : Mordellidae |
| 41. Sandy beaches | : Cicindelidae |
| 42. Decaying logs & stumps | : Lucanidae, Passalidae |
| 43. Fruits | : Scarabaeidae |
| 44. Seeds | : Bruchidae |
| 45. Herbaceous plant | : Chrysomelidae |
| 46. Mine galleries of heart wood | : Platypodiidae |
| 47. Phytophagus | : Chrysomelidae,
Curculionidae |
| 48. Saprophagus & Mycetophagus | : Nitidulidae |
| 49. Carnivorous | : Prionoceridae, Malachidae |

Strepsiptera

(Stylops)

Stylops are very small insects. The length of the body varies between 0.5 and 4.0 mm. The males are with a pair of hindwings but the forewings are reduced to halteres. The females are legless, wingless and grublike.

Habitat

The females are generally endoparasitic and larviform in structure and remain enclosed in a puparium of the host. The larvae, in both sexes are endoparasitic and found in the body cavities of the different insect-hosts belonging to the Orders Orthoptera, Hemiptera, Diptera and Hymenoptera.

Collection

The best method to collect the stylops is to look for them in their hosts, namely, styloped Hymenoptera or other insects as mentioned. These styloped insects may be kept in captivity for obtaining the males. However, the males are sometimes found at light. For the collection of females and the larvae, the styloped insects may be dissected.

Preservation

Both the larvae and the adults may be preserved in 80% ethyl alcohol.

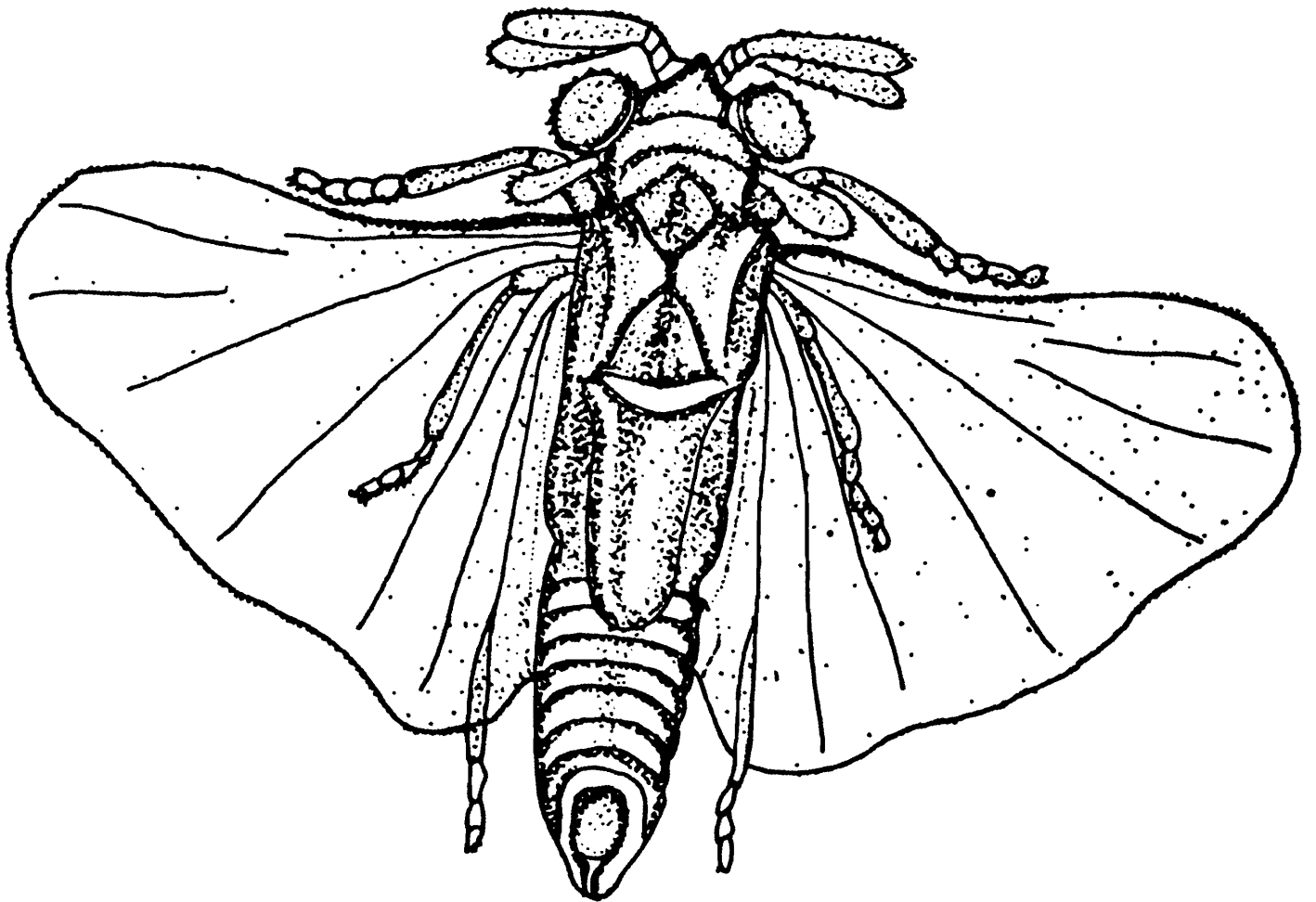

Strepsiptera (Stylops)

Acari

The Acari, comprising of mites and ticks, are of immense economic importance in agriculture, medical and veterinary sciences. Their sizes vary considerably from as small as 100 microns to as big as 3 cm. They occupy diverse habitats from lowest intertidal zones to top of mountains, in salt and fresh water, in pasture and arable land, in forests, orchards, crop fields and in intimate association with vertebrates and invertebrates as external or internal parasites. According to their habitats they may be classified into *free living forms* and *parasitic forms*. The former may be (i) predaceous (ii) phytophagous, (iii) microphagous, (iv) saprophagous, (v) microphages & necrophages and (vi) phoretic, while the latter group may be (i) ectoparasitic (vertebrate parasite or invertebrate parasite) or (ii) endoparasitic (vertebrate parasite or invertebrate parasite). While over 30,000 species under 1700 genera are known from the world, the Indian acarine fauna is represented by about 2,000 species under 600 genera belonging to 170 families. Because of the great diversity in their habits and habitats, the techniques involved in their collection and preservation also vary considerably.

Collection

Soil mites

Direct collection : A handful of soil rich with decaying organic matter when taken into a white enamel tray and examined with a hand lens of 10X magnification, a large

number of mites will be visible specially when soil sample is gently teased with a fine needle. Those are picked up with a brush moistened with ethyl alcohol.

Heat desiccation method : The modified Tullgren's apparatus consists of a galvanized funnel (10-15 cm) which rests on a wooden stand and a heat source (an electric bulb of 40-60 W) kept suspended over the funnel from a wooden support, maintaining a distance of 5-10 cm. The soil sample in upside down position is kept in the wire mesh (1.5-2.5 mm) kept suspended inside the funnel. The heat from the electric bulb desiccates the soil and the mites start downward movement through the microholes already present in the sample. While doing so, they reach the wire gauge, finally fall in the receiver (containing 70% ethyl alcohol) fitted with the stem of the funnel and, thus, are collected. The wattage of bulb, its distance from the soil sample and duration of extraction will depend upon the moisture content of the soil. Ordinarily a bulb of 40 W, distance of 5-10 cm and duration of extraction for 3-4 days may be advisable for moderately moistened soil sample. When several soil samples need to be extracted, a battery of Tullgren's funnels may be used. The funnels may be kept inside a wooden box to increase the efficiency.

The same method may also be used for extraction of mites from leaves, bird's/mammal's nests, feathers, caged animals, stored grains, etc.

Flotation method : Soil samples are stirred with $MgSO_4$ (specific gravity 1.2) solution and a stream of air is blown simultaneously into the solution. After sometime, the liberated animals and organic debris float on the surface and those are

collected on a filter paper or on a sieve. Salt and Hollic have slightly modified the method by introducing (i) prewashing and sieving of the samples before going in for flotation method and (ii) introducing benzol-water solution for partially separating animals from plant debris in the float. The float is shaken vigorously with benzol-water solution in a flask wherefrom air is drawn out to reduce the pressure which helps to draw out the air from plant debris. After this operation is over, the atmospheric pressure is reintroduced which results in sinking a fair portion of plant debris, and the upper portion of the mixture thus largely contains mites along with other arthropods.

Parasitic mites

Vertebrate parasitic mites

Combing and brushing : The live or dead hosts like birds, mammals, etc., are when combed or brushed over a shallow dish, the ectoparasitic mites, if present, fall on the tray wherefrom those may be collected with the help of a moistened brush.

Application of repellent on host body : The host is put in a cylinder, with its head and neck protruding through a hole in the upper lid. Chloroform fumes/"dry die" pyrethrum is then pushed into the cylinder and th bird is encouraged to flutter. All the mites drop off on a white tile or cloth bag kept at the bottom of the cylinder.

Light trap : A light trap for collecting unattached mites can also be used. A tray (3 sq.ft.) with sides 8 cm deep and painted black inside has a central hole of 5.5 cm diameter. The

tray is put on the ground in inverted position and a 5 cm specimen tube is fixed tightly by rubber in the central hole. This tube is the only source of light when the tray is set. A petridish carrying a filter cone is placed directly beneath the fixed tube and the contact below the cone and the tube is obtained by a second specimen tube of 4 cm diameter. The closed end of the contact tube can slide freely within the outer fixed tube by means of a grooved rubber ring and the open end of the contact tube rests on tip of the filter cone. Since the trombiculid mites are positively phototropic, the free unengorged larvae move towards light, move to the petridish and then come to the outer tube through the contact tube and rubber groove.

Internal parasites : The internal parasitic mites infesting the nasal passages of birds and reptiles can be collected by flushing soap water through one of the nostrils and collecting the fluid emerging out from the other nostril. The fluid when examined yields mites. Internal parasites of lung tissues can be collected by dissecting out the relevant portion of the body and examining under stereo-binocular microscopes. The skin parasitic mites can be collected by Hopkin's dissolution technique using hot KOH or NaOH for dissolving skin.

Ticks : The ticks can be collected by directly examining the host and picking those by a fine forceps. Before doing that, it will be better if the host is first brushed with glycerol or paraffin which will relax the ticks. This will prevent damage to the ticks.

Internal parasitic mites

Direct examination : The invertebrate associated mites can

be collected by direct examination of the host under stereobinocular microscope. Mites from museum specimens can be collected first by wetting the body with 70% ethyl alcohol and then removing the mites by a brush.

Plant mites

Handpicking : Infested leaves are directly examined under a 10X hand lens and mites are picked up with a fine brush moistened with ethyl alcohol. Better result is obtained when the infested leaves are brought to the laboratory in a polythene bag and examined under stereobinocular microscope.

Sweeping and beating : In the former method, the bushes when swept with an insect collecting net, a large number of mites will get entangled in the inner wall of the net and those are picked up with a fine brush. In the latter method the infested leaves are beaten over a tray padded with cotton wool. the mites get dislodged while beating and after falling in the tray get entangled in the cotton wool. The mites are then picked up with a fine brush.

Aspirating : A singer type aspirator is quite convenient for collecting plant mites as it helps in collecting the mites from its habitat into the preservative directly.

Flotation method : Infested leaves are put into a jar containing water and a detergent (teepol) is added to it. The jar is shaken vigorously. All the mites get dislodged and are collected by filtration.

Special method for eriophyoids : The gently opened galls are put into an opaque glass jar in an airy room away from direct sunlight. With the drying of galls the mites emerge out

and start crawling in the inside wall of the jar which is previously wiped with glycerol, 5 cm below the mouth of the jar to avoid their escape. Later, previously warmed chloropicric acid is poured over the dried plant parts and the jar is shaken vigorously. Later, when the plants get settled, the liquid is decanted and filtered for getting the mites.

Aquatic mites

Hand picking : The parasitic aquatic mites can be collected from the host by direct examining it with a hand lens and collecting with a brush.

Netting : Free living mites can be collected by using nylon nets of narrow mesh fitted with an iron ring on a long handle. Another type of net is the Birge net. It consists of a funnel-shaped net, with a fine sieve fitted with a long wire enabling to pull the net into deep water. The contents of Birge net are examined for mites in a white porcelain tray. The marine aquatic mites attached with some substratum are collected first by dredging the substratum and those are broken into pieces and kept in a bucket containing sea water and chloroform (15 cc). The liquid along with substrate are poured from one bucket to another several times for complete anaesthetization of mites. The liquid is then filtered through a muslin bag for collection of mites.

Dust mites

The dust mites are collected in the following stages : (a) First of all a small quantity (2 gms) of dust sample is washed with kerosene oil in a beaker and stirred with a magnetic stirrer for about 15 minutes at slow speed. The liquid is filtered

through a 500 μ sieve. (b) The material on the sieve is washed in a beaker by kerosene oil jet and filtered through 500 μ sieve and the filtrate is added to first. (c) Filtrates (a) and (b) containing fine dust with mites in kerosene oil are sedimented and the supernatant is filtered through Buchner funnel. (d) The sediment is mixed with kerosene oil and Carbon tetrachloride (1:3) (Sp.gr. 1.4) and centrifuged, then filtered. Lastly, the sediment is mixed with pure CCl_4 (Sp.gr. 1.6) and the process is repeated. However, most of the mites are collected in steps (c) and (d) above.

Stored grain mites/Nest mites

Heat extraction method described earlier in case of soil mites can be used for collecting these mites.

Preservation

All the mites and ticks excepting eriophyoids can be preserved in 70% ethyl alcohol. Eriophyoids are better preserved in dry condition by wrapping the infested leave - galls in tissue paper and from there mites can be brought to normal condition by simmering in Keifer's preparatory solution (Resorcinol - 50 gms, Dyglycolic acid - 20 gms, Glycerol : 25 ml and some iodine). Oudemans's fluid (70% alcohol - 87 parts, Glycerol - 5 parts, and lactic acid - 8 parts) or Keonike's fluid (Glacial acetic acid - 10 parts, Glycerol - 50 parts and distilled water - 40 parts) may also be used as preservatives. All the tubes containing mites or ticks in preservative are to be plugged with cotton wool and are kept in inverted position in a big jar. The jars should contain enough alcohol to keep the tubes in fully immersed condition. Both tubes and jars should be properly labelled giving necessary collection data.

Cleaning : The highly sclerotized oribatid mites may be cleared by keeping the specimens for 15-60 days (depending upon the degree of sclerotization) in lactophenol solution (Lactic acid -50 parts, Phenol crystals - 25 parts, distilled water - 25 parts). In highly sclerotized forms, the mite body may be punctured with a fine needle for deep penetration of lactophenol. The other chemicals which are used for clearing of mites are: Andre's fluid (Chloral hydrate - 10 parts, Phenol - 9 parts, distilled water - 25 ml, Conc Hcl - 2.5 ml). For eriophyids, Kono's fluid (Chloral hydrate - 100 gms, Glycerol - 10 gms, Conc Hcl - 1 ml, distilled water - 50 ml) may be used.

Temporary mounting : This is usually done by keeping the specimen in a drop of lactic acid on a microslide and a small broken piece of coverslip is put over it. The slide is then gently warmed over an electric lamp for a few seconds till the fumes of lactic acid start coming out. If this process of heating is repeated several times depending upon the degree of sclerotization, the mites will be in a fairly good condition for study under microscope. In case of highly sclerotized forms, the specimen may be required to be kept in lactic acid medium for several days. For soft bodied specimens, small glass bits may be kept around the specimens on which should be put the broken piece of coverslip to protect the specimen from the direct pressure of the coverslip and thus avoid being damaged. Cavity slide may be used for easy orientation of the specimen.

Permanent mounting : Several mounting media are available for mounting of mites but the most used ones are : Hoyer's medium (Distilled water - 50 ml, Gum arabic - 30 gms, Chloral hydrate - 200 gms, Glycerol - 20 ml) and Faure's medium (Distilled water - 50 ml, Gum Arabic - 30 gms,

Chloral hydrate - 50 gms, Glycerol - 20 ml). Heinze's medium (Polyvinyl alcohol - 10 gms, distilled water - 40 ml, Lactic acid - 35 ml, Glycerol - 10 ml, Phenol aqueous solution - 25 ml, Chloral hydrate - 100 gms) is the other medium which is also used. All the permanently mounted slides after being dried should be ringed with a good quality nail polish or Glyptal (a GEC product).

Some important points

1. For collection of plant/animal parasitic mites, the identification of the host is very essential and hence the host should be correctly identified.
2. If necessary, the dissection of the specimen should be made under stereobinocular microscope.
3. While sending the specimen to outside specialist for identification, it should be sent preferably preserved in 70% ethyl alcohol.

Araneae (*Spiders*)

Habitat

These inhabit herbs, shrubs, trees and also in dwelling or abandoned houses.

Collection

A large number of spiders can be collected by beating the bushes, herbs, shrubs and trees over an open umbrella held in inverted position. The spiders get dislodged and fall in the umbrella wherefrom those are picked up with fine forceps or a brush. An ordinary insect collecting net when swept over

bushes, trees, etc., a lot of spiders entangle on the inside wall of the net and can be picked up by a brush.

Preservation

70% ethyl alcohol.

Chilopoda (*Centipedes*)**Habitat**

They normally occur under stones, in cracks and crevices, under tree barks as well as under logs left lying on the ground.

Collection

By hand picking with wooden or metallic forceps.

Preservation

70% ethyl alcohol.

Diplopoda (*Millipedes*)**Habitat**

They occupy damp places, rich with decaying organic matter. They also abundantly occur in crop fields, orchards, etc.

Collection

By hand picking with the help of forceps.

Preservation

70% ethyl alcohol.

Xiphosura (*Limulus*)

Habitat

They occur in marine habitat.

Collection

Generally, collected by netting.

Preservation

70% ethyl alcohol; also may be preserved in dry state.

Scorpiones (*Scorpions*)

Habitat

They occur under stones or tree bark. Also they may be found in cracks and crevices of the wall.

Collection

By hand picking with forceps.

Preservation

70% ethyl alcohol.

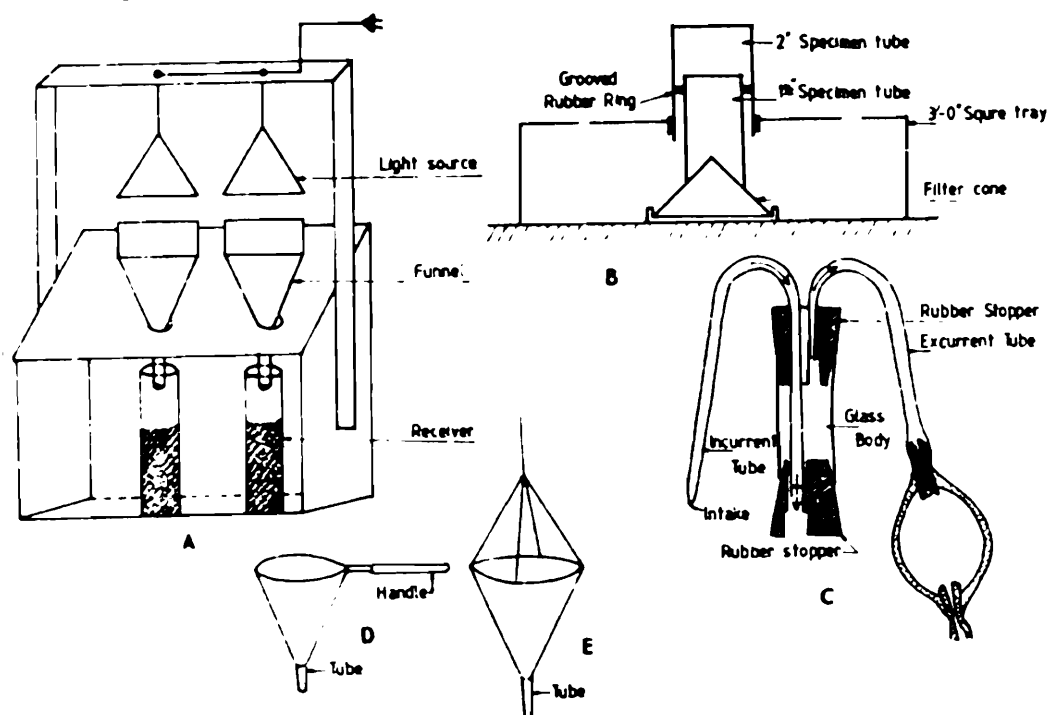

Collection equipment for Acari

A. Tullgrens apparatus; B. Light trap; C. Aspirator; D&E. Aquatic nets.

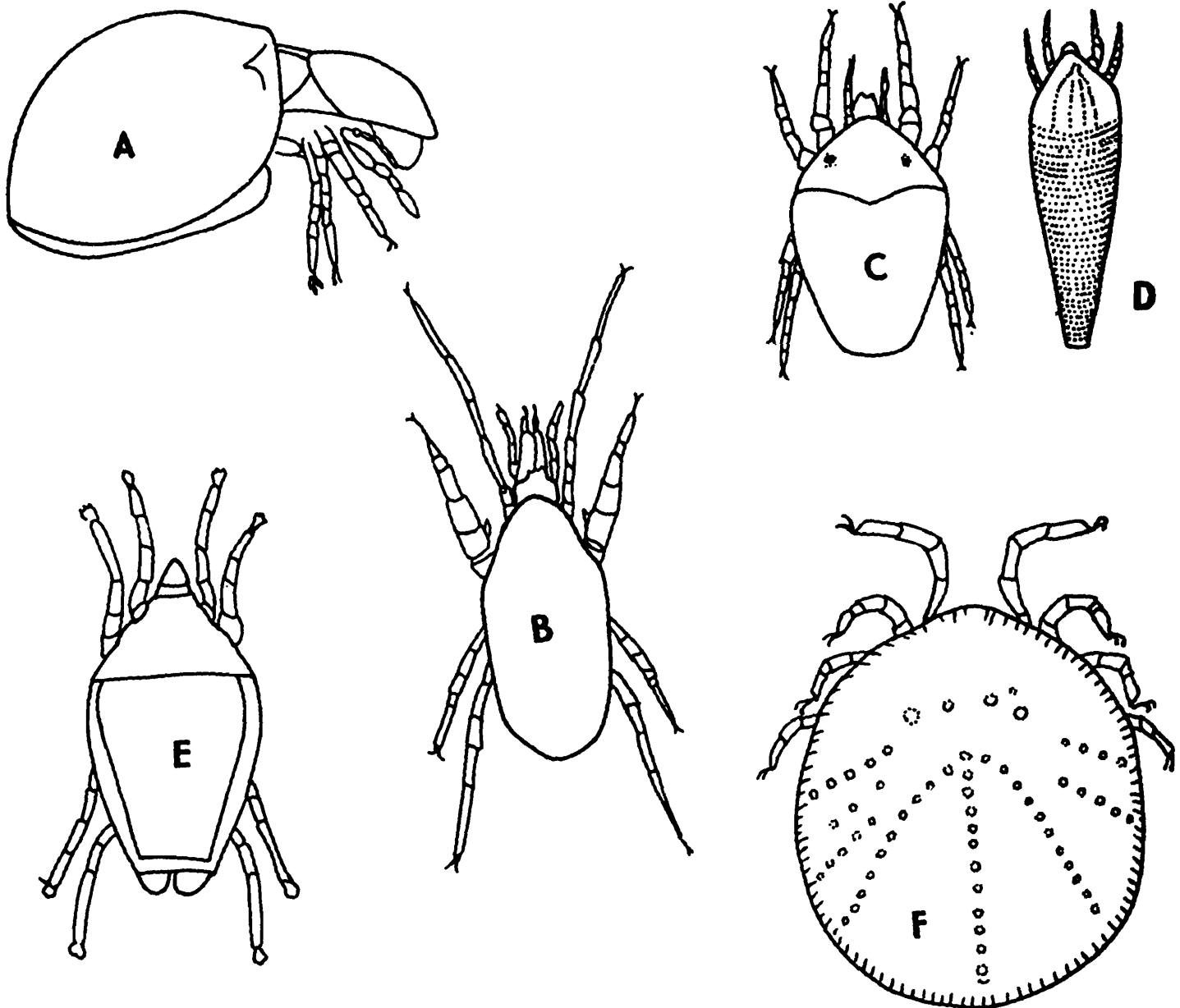

Acari (Mites)

**A. Cryptostigmata; B. Mesostigmata; C&D. Prostigmata;
E. Astigmata; F. Metastigmata**

Mollusca

Molluscs are soft bodied animals protected, in the majority, by a shell. The phylum Mollusca is classified into seven classes, of which only five classes have their representatives in India. All the five classes, namely Polyplacophora, Gastropoda, Scaphopoda, Bivalvia and Cephalopoda are represented in the marine environment, while two classes namely, Gastropoda and Bivalvia are more dominant than the rest in terms of number of species and their adaptability to the available ecological niches. These latter two classes have also successfully colonised freshwater habitats, and those of the Gastropoda terrestrial ecosystem. Thus molluscs in India have a wide range of distribution extending from depths of the oceans (about 3600 m) to higher altitudes of Himalayas (about 4000 m above MSL). Molluscs occur in diverse habitats, and the techniques of their collection and preservation are as diverse as their habitats. There are special techniques for each class of molluscs as they follow different life styles and exhibit different reactions to treatment in the field.

Molluscs are conspicuous and abundant in any productive aquatic ecosystem and can be considered as treasures within arm's reach. Those who are engaged in the collection of non-marine molluscs will come across individuals/populations belonging to the classes Gastropoda and Bivalvia. Although individual initiative and effort are the two factors responsible for a good collection, a forehand knowledge of habits and

habitats of molluscs, a sensible and suitable choice of collecting equipments and a large measure of patience and perseverance will open up unlimited possibilities of acquiring a beautiful and complete collection. A general account of major common molluscs is presented below, which would facilitate one to develop an idea on the habitats and collection of some common molluscs.

Habitat

All molluscs have their particular ecological niches or favourite haunts and follow specific life styles. They can be broadly considered under three heads, namely marine, freshwater and land.

Marine molluscs : Molluscs are more abundant in marine environment than in freshwater or on land. The marine environment has two divisions, namely, benthic and pelagic. The former is again divided into littoral, sublittoral and deep sea zones, while the latter includes neritic or coastal zone and oceanic or offshore zone. Only a few groups of molluscs like pteropods, heteropods and cephalopods have developed the swimming pelagic existence and occur in the pelagic part of the sea. Benthic division is more productive as far as molluscs are concerned. The littoral region abounds in molluscs which have colonised almost all conceivable habitats. Benthic molluscs occur either as infauna burrowing into the substratum, rocks, corals and other structures, or as epifauna-attached surface dwellers on rocks, algae, corals, etc. A search in the rocky intertidal region or coral reef area will be a rewarding experience for a mollusc collector. Ideal spots for collection are coral reef ecosystem off Andaman and Nicobar Islands, Lakshadweep,

Gulf of Mannar, Gulf of Kutch and rocky coast along east and west coasts of India. Sandy beaches have their specialised fauna and one should have special technique to make collections in such areas. Molluscs also occur in the offshore and deep sea waters. In the latter zone are found a number of bivalves.

Freshwater molluscs : Broadly they fall under lentic or lotic forms. In general, gastropods occur in the littoral region attached to vegetation or under stones. Bivalves are benthic forms which live partly buried in the soft mud. Where the bottom of a pond or tank is either too hard or too soft they may not occur. There are certain freshwater molluscs which have restricted distribution and occur in specific geographic areas of India. A search in the aquatic vegetation growing in stagnant ponds or tanks may be rewarded with gastropods. Except a few, molluscs can be easily seen and located with the naked eye in the habitat of their natural occurrence. Although any aquatic body with vegetation may support some mollusc fauna, the streams in the Western Ghats, Northeastern India, Andaman & Nicobar Islands are favourite haunts for *Paludomus*, neritids, melanids, etc., among gastropods. A few freshwater bivalves, like freshwater oysters and *Solenaia*, are restricted to streams of Karnataka and streams of Northeast India respectively.

Terrestrial molluscs : Land snails and slugs prefer damp and moist situations and occur under leaves, stones or sometimes under the bark of trees. Calcareous soils may support rich mollusc fauna. Land snails and slugs can be found in tropical rain forests of Northeast India and Western Ghats. Some of the characteristic land molluscs occur in moist humid tracts of Subhimalayan mountains. Slugs are recorded on the top of the Himalayas at an altitude of 4000 m above sea level. Bushes and

scrub jungles in the arid and semiarid zones support special type of molluscs.

Collection

Most of the molluscs are sufficiently big and conspicuous and, hence, can be handpicked. The best time for collecting marine molluscs is during low tide. By looking under the coral-rocks or in the crevices of rocks one can spot molluscs and pick them up with a forceps. Some of the molluscs which live inside the corals are to be obtained by breaking open them. Special equipment is needed for collecting sand dwelling forms and benthic bivalves. Shovels and spades are useful in digging out the sand on the beach. The sand is put into a sieve and filtered leaving the animals in the sieve. The mesh-size may vary depending on the size of the mollusc to be collected. Trawls, grabs, and dredges, are used in the collection of benthic molluscs in the marine environment. The techniques are same as those used in the macrobenthos sampling of the sea bottom. Wood boring molluscs are extracted from the wood by hammer and chisel.

The following equipments are useful in collecting freshwater snails : a hand net or water net or a scoop-net, ordinary sieves with metallic frame, a small piece of cloth (preferably of 1/2 sq. m), a few polythene bags, specimens tubes/bottles (assorted sizes), a thermometer, forceps, enamel trays/petridishes, chemicals-narcotizing agents and preservatives, a field note book and data sheets and labels.

A hand net is made of a fine mosquito net fixed to a round steel ring, which is fitted to a wooden handle. A scoop net, as

suggested by Malek & Cheng (1974, Medical and Economic Malacology, p. 379) is usually a metallic one with 30 cm x 30 cm frame of steel bars fitted with wire netting. A 10 cm deep scoop is soldered to the frame with 8 cm wide blade. The hand net is dragged over the aquatic vegetation, and when it is filled with aquatic weeds, the contents are poured out on a spread-out cloth piece. The leaves and branches of the plants are carefully searched and the snails are picked up with a forceps. Small specimens such as *Gyraulus* and others should be removed with the help of a brush. At times it may be necessary to wash the weeds in an enamel tray. The specimens are then transferred into specimen tubes or bottles. All the relevant data should be noted down in the field note book or data sheet.

In the case of bivalve molluscs a dredge has to be used for collecting. However, bigger specimens can be hand-picked from the bottom of a small pond or a slow moving stream. Pea clams and other bivalves are collected from ponds and tanks, big streams or rivers with the help of a hand dredge or dredge operated from a boat. When the collections are to be made in small streams or drains the bottom mud should be scooped and put into an ordinary sieve and washed with water. By repeated washings, mud will be cleared and small specimens that of *Pisidium* or *Sphaerium* can be easily picked up from the sieve.

To collect land molluscs of small size, the usual method applied for soil invertebrates is useful. But large specimens, those which can be easily spotted with the naked eye are to be hand-picked or picked up by a forceps. During monsoon, snails and slugs can be seen crawling on the ground or on damp walls and vegetation. During other times, decomposed litter or debris has to be slowly removed to see whether there are any snails.

Some snails are found in the folds of the banana leaves and plants. One has to choose the likely spots where snails may occur. Then slowly remove the surface soil or clear the debris. Collecting land molluscs is more difficult than that of freshwater and marine.

Fixation

Narcotization : Molluscs react when they are handled in the live condition and, hence, it is essential to narcotize them before fixation. Narcotization is however not needed for Cephalopods (Squids, Octopus, etc.) as they soon die when removed from seawater.

The collection of aquatic molluscs should be placed in an enamel tray filled with either sea water or pond water, as the case may be making sure that the specimens are completely immersed in water. Then finely powdered menthol or magnesium sulphate or chloral hydrate should be sprinkled over the surface of water and covered by a lid. Magnesium sulphate may be added in crystal form and the time required may vary from 2 to 6 hours. When menthol is used, narcotization takes about 12 to 24 hours, depending on the nature of specimen. The collection should be inspected after 12 hours to ensure that decomposition has not set in. When completely narcotized the specimens lie in fully extended condition.

Formalin (4 percent solution of formaldehyde) may be added in drops, 3-4 at a time, repeating every 1/2 hour until the animals are narcotised. This method is good for some species of nudibranchs.

Narcotized molluscs if they are of large size, particularly

opisthobranchs (and also cephalopods) should be injected with a small quantity of the selected fixative before transferring them into fixative solution - small specimens do not require any injection.

Freshwater snails and bivalves can also be relaxed by plunging them into boiling water. Solution of propylene phenoxetol (0.5%) is a good relaxing agent for marine bivalves.

Land snails and slugs can be killed by asphyxiation. A glass bottle or jar is fully filled with water, and the specimens are plunged into it, then the mouth of the bottle/jar is closed with a lid making it air tight. Deoxygenated water or addition of a few drops of spirit at intervals, may help in rapid killing. The specimen may extend fully and get relaxed in about 20 hours. However, a close watch should be maintained, and when the animals are found lying completely dead or motionless they should be removed and treated with ascending grades of alcohol (30%, 40%, 60%, 70%).

Narcotized specimens should be given a series of washes with tap-water so as to remove the affects of reagents and also the mucus exuded from their body. Particularly, land snails and slugs secrete a large amount of mucus and a thorough wash under tapwater is essential.

Preservation

Soft parts : After narcotization, specimens are thoroughly washed, treated with different grades of ethyl alcohol and finally preserved in 70% ethyl alcohol. Shellless molluscs should be preserved in 4% formalin. This method works particularly well with nudibranchs, in which colour is also preserved.

Specimens needed for anatomical or histological study are fixed either in hot Bouin's fluid (Sat. aqueous picric acid, 75 ml; Formalin, 25 ml and Glacial acetic acid, 5 ml) or Alcohol-Formalin-Acetic Acid combination (AFA) (70% ethyl alcohol, 100 ml; Formalin, 5 ml and Glacial Acetic Acid, 5 ml). Time of fixation varies from 20 to 24 hours and then the snails are removed and thoroughly washed in running tapwater.

Dry shells : While preserving some shells with the animal intact, it is a good practice to preserve a few dry shells separately. After narcotization, the animal is extracted from the shell with a bent-tipped forceps. Empty shells may be boiled in water for about half an hour so as to remove any soft tissue sticking inside the shell. The shells can be further cleaned with a smooth brush, and then dried in the air. In the case of operculate shells operculum should be retained by pasting it to a cotton plug inserted into its aperture.

Marine shells such as cowries, olives and a few naticids which have a polished surface should never be plunged directly into boiling water. These shells should be first treated with warm water and then with boiling water. Burying the marine shells under soft dry sand and leaving them in that condition for about a week, has worked out well in a number of species. It is however, easy to clean bivalve shells.

Small dry shells may be packed in cotton in small glass vials or tubes or card board boxes depending upon the size of the sample.

Labelling

A collection is of little scientific value if it is not

accompanied by the relevant data, namely locality (specifying its habitat), date of collection, collector's name, etc.

Temporary labels can be used in the field and final labels should be given after returning to the laboratory. Permanent labels should be written with indian ink or soft lead pencil on a good cartridge paper.

Packing for despatch

When sending shells to an expert for identification, always include the full collection data inscribed on a label and enclosed with each lot. Small specimens should be carefully placed in tubes provided with cotton padding. Large specimens may be wrapped with cotton, and packed in a polythene bag. The packet containing specimens should be packed in a good wooden box or a tin container of suitable size after providing a good lining of paper or cotton wool on all the sides and also inserting waste cotton or crumpled thermocole or waste paper in between the tubes/packets so as to prevent damage during transit. If the collections are wet, the containers should be sealed to prevent leakage and then packed in a polythene bag.

Hemichordata and Protochordata

Protochordata, which consists of subphyla Tunicata (=Urochordata) and Cephalochordata, are primitive chordates. They either as adults or at some stage of their life-cycle, possess the three chordate characters, a notochord, a dorsal tubular nerve cord and pharyngeal gill slits. Hemichordates which also possess gill-slits, differ from cephalochordates in the notochord being a modified buccal diverticulum of endodermal origin and the nervous system devoid of a dorsal tubular nerve cord.

Both the hemichordates and protochordates are exclusively marine. Their distribution in different habitats and method of collecting are described here.

Collection

Hemichordata : This consists of the enteropneust worms, solitary or colonial pterobranchs and planktonic Planctosphaeroidea.

Intertidal forms : The enteropneust worms are found along the beaches of Krusadai and Pulli Islands off the Gulf of Mannar, and the islands of Andaman and Nicobar, and Lakshadweep. *Phycodera flava* occurs in the Gulf of Mannar, in the shingle mixed sand, and is located either by the iodoform smell or by the spiral castings left behind by the burrowing worms. *Glossobalanus minutus* is another species which is

found on the shores of the Andaman and Nicobar and Lakshadweep Islands, in the dead coral mixed sandy beaches.

Both the above mentioned species are large and can be collected by shifting the sediment between the fingers or in a sieve of 2 mm mesh. A broad spade may be used to shovel the sediment around the spiral castings to avoid any damage to the specimen.

Planktonic forms : *Glandiceps malayanus* is the only enteropneust worm so far known to be collected occasionally in a plankton net. The tornaria larvae of all enteropneust worms, and *Planctosphaera pelagica* occur as meroplankters. They are collected both by towing the net horizontally and by hauling the net vertically in deep waters.

Benthic forms : Majority species of enteropneust worms are benthic and are obtained by dredging.

The pterobranchs, which are benthic, are of three types :

- i) *Rhabdopleura* - colonial worms, connected serially, and living inside the transparent thread like branched tubes, which ramify over the dead lamellibranch shells, tests of tunicates, and on blades of seaweeds.
- ii) *Cephalodiscus* - unconnected individuals, living in a colony, formed by an encasement called Coenecium.
- iii) *Atubaria* - solitary worms crawling over weeds and large hydroid colonies.

All these three groups of pterobranchs occur on the sea-floor between 5 and 500 m depth, and are obtained by dredging with a rectangular Naturalist's dredge.

Tunicata : The entire animal or the colony of tunicates is enclosed in a transparent or opaque encasement known as tunic. Three classes of tunicates namely, Ascidiacea, Thaliacea and Larvacea are recognised. The ascidiaceans are sedentary forms, found solitary or in colonies. The thaliaceans and the larvaceans are pelagic and are found at different depths in the sea.

Intertidal forms : The ascidians are sessile or stalked sac-like tunicates, usually encrusted with foreign bodies. They are found either as solitary individual or in colonies, attached to or encrusting on rocks, seaweeds, drift wood or large broken shells. Some monoascidians are found embedded in sand and are easily scooped out. However, care should be taken to slice off the base of forms attached to rocks. Colonial forms should be collected, preferably along with their substratum, to enable the study of budding forms, and the colony can be separated by carefully teasing with a hard needle in the laboratory.

Planktonic forms : Pelagic tunicates (Salps, Doliolids and Pyrosomes) occur at all depths in the sea and are collected with a plankton net. International Indian Ocean Expedition team used an International Oceanographic standard plankton net of 0.33 mm mesh for their collection. This net strains water effectively to collect Thaliacea and Larvacea in large numbers. But minute Larvaceans and polymorphic forms of doliolids including tadpole larvae of ascidians are well collected either with an organdie net or No. 20 bolting silk net.

Mesopelagic forms : Large salps like *Thetys vagina*, *Iasis zonaria* and *Metcalfia hexagona* are found in this region. This

can be collected by operating an Issacs-Kidd Midwater Trawl net on board a fishing trawler.

Abyssopelagic forms : Doliolids occur at depths between 1500 and 2500 m. A plankton net with a closing mechanism will be very helpful to avoid back wash and loss of plankton while hauling vertically.

Benthic and abyssobenthic forms : Deep water dredging by Oceanographic Expeditions has proved the presence of monoascidians up to a depth of 1000 m. During Challenger Expedition, a new group of abyssobenthic ascidians, i.e. *Octonemus*, were dredged from a depth of more than 2000 m.

Cephalochordata : These are fish-shaped, laterally compressed animals, with their anterior and posterior ends pointed, and commonly known as lanceolets. These are found half burried in vertical position.

But for the larvae which are planktonic and obtained in a plankton net, the adults are benthic and live in coarse sandy bottom from a depth of 5 m onwards and can be collected by dredging.

Preservation

As a rule, all protochordates must be fixed in 4% formaldehyde solution prepared in sea water, as the isotonicity between the preservation medium and the animal's body fluid helps to prevent any deterioration during prolonged storage. Narcotisation in 5% Magnesium chloride before fixing, helps to study the hemichordates and ascidians. For histological

studies, the animal should be fixed in Bouin's fluid and stored in 70% ethyl alcohol.

Sorting

The preserved material is sorted out. Larger species are sorted out with naked eyes, but the smaller species like the pelagic tunicates are sorted under stereoscopic binocular microscope and picked out with fine needles. The sorted material are stored in vials having stoppers.

Labelling

Each vial should have a label written with a soft pencil. Each label should have the date and time of collection, location (if at sea, the grid reference), name of collector and environmental parameters to aid in ecological studies. In addition, a data sheet is also maintained to help in further analysis of the data.

Preparation of material

For detailed histological studies of enteropneust worms, compound ascidians and atubaria, microtomic preparations are made. The monoascidians, pelagic tunicates and cephalochordates need to be prepared as follows.

The tunic of monoascidians should be dissected out from the mantle with utmost care and the latter should be stained in 0.1% Rose Bengale solution.

While sorting, the pelagic tunicates should be transferred to an embryo-cup containing 0.1% Toluidin Blue solution for the

tunic to take stain and later into 0.1% Rose Bengale solution for the muscles and other organs to take stain.

Cephalochordates are stained with 0.1% Rose Bengale solution to study meristic characters.

Packing for despatch

The glass vials or the slides containing the specimens should be wrapped in tissue paper and then packed in a wooden or tin container, as the case may be. Soft packing material may be used for padding.

DATA SHEET FOR MARINE COLLECTIONS

Cruise No.....

Area of Investigation

Station No

Date..... Time Lat. N

Long. E Gear used.....

Depth of Stn..... Depth of haul

Species Composition of Haul :

.....
.....
.....
.....
.....
.....
.....
.....

Remarks :

Hydrological Parameters

.....
Depth
 Surface 10m 20m 30m 100m 200m 500m

Parameters
.....

Temperature
.....

Salinity
.....

pH
.....

Oxygen
.....

Signature of Scientist

Address

Fishes

India is rich in water resources. There are many reservoirs, lakes, streams, rivers, seas and oceans which support a great variety of aquatic life. One of them is fishes. Fishes are found both in fresh and marine water.

Collection

Freshwater fish

The following types of gear and methods are generally used for collecting freshwater fish.

Seine net : This net is commonly used in lakes and streams. A long, shallow, net, so short as to capture all fish within the area served by it. The length may vary from 1 to 15 m, depth about 1 m, and size of mesh 3-12 mm square. The net is attached to a leaded line below and a line above, floated by cork, wood or plastic. When in use, a wooden pole, 1.5-2 m long, is fastened to both lines at each end of the net to keep it spread out. Large nets are operated by two men. In shallow waters, small creeks among rubble, thick vegetation, etc., a small net is used. The two persons working a net should stir up the bottom to drive the fish into the net. In deeper waters, the net is set from a boat and hauled shorewards by long lines.

Cast net : This net is usually from 6 to 15 m in diameter and conical in shape. This is operated by hand. When thrown, it spreads out, trapping the fish.

Bag net : This net is useful for collecting small fish in shallow waters. This is like a butter-fly net but more strongly built, having a long handle and thick meshed net.

Damming : This method is usually practiced in mountainous regions. A small portion of a stream is dammed and the water diverted. The channel below the dam dries up. A great variety of hill stream fish can be picked up from underneath the stones.

Poisoning : This method is commonly used in streams. Rotenone is generally the active and lethal agent in fish poisons (1 part of rotenone in 20 million parts of water is sufficient to kill the fish). Care should be taken to avoid indiscriminate killing.

Marine fish

On rocky shores between tide-marks interesting fish can be collected by lifting up boulders and stones. Larger rock pools and roots of seaweeds should be searched with a hand net. In sandy and muddy shores and estuaries, the pools and runnels left by tide should also be searched by a hand net. Below tide marks in shallow waters with sandy or muddy bottom, the seine net is used. In deeper waters, trawling is the best method. To suit local requirements, several distinct types of gear have been evolved, and such gears should be used where possible.

Preservation

Ethyl alcohol or formalin are generally used for preservation. As soon as possible, the live fish should be dropped in a 5–7% solution of formaldehyde. This solution is

sufficient to fix and preserve small fish in 2 or 3 days. Larger specimens require longer time. Specimens over 75 mm in size should be split in the belly with a knife to enable formalin to enter into the body cavity. Large fish, especially with soft bodies, are injected with the formalin to enter into the body cavity.

Formalin, though good as a fixative, is not good for permanent preservation. Its acid content dissolves lime from bones and makes the specimens flabby. Further, formalin fumes irritate the eyes of those who study the specimens.

For permanent preservation in museums, etc., the most suitable method is to fix the specimens in formalin and then transfer them to alcohol. In transferring, it is better to dehydrate the specimens gradually in 30%, 50%, and 70% ethyl alcohol.

Very large specimens are skinned and preserved by applying arsenical soap or common salt on the inner surface.

Labelling

Labels should be written on stout paper, with a soft lead pencil. The essential particulars required are : locality, date of collecting, name of collector and the collection number/lot number. The colour of live specimen and the ecological particulars, if any, should also be noted.

Packing for despatch

Small fish : Wrap the specimens in a white cotton cloth or cotton wool moistened with a weak solution of formalin and put a label with each specimen or lot. Pack such bundles in a tin container, solder the lid and place it in a wooden crate. For

despatch by air, fish wrapped in soaked cotton wool is kept in a polythene bag, sealed and packed in a cardboard box.

Medium sized fish : As above, but each specimen should be wrapped separately and must have a label.

Large fish : Large fish is usually skinned, leaving the head and gills intact. The preserved specimen is rolled up and packed in a box as above.

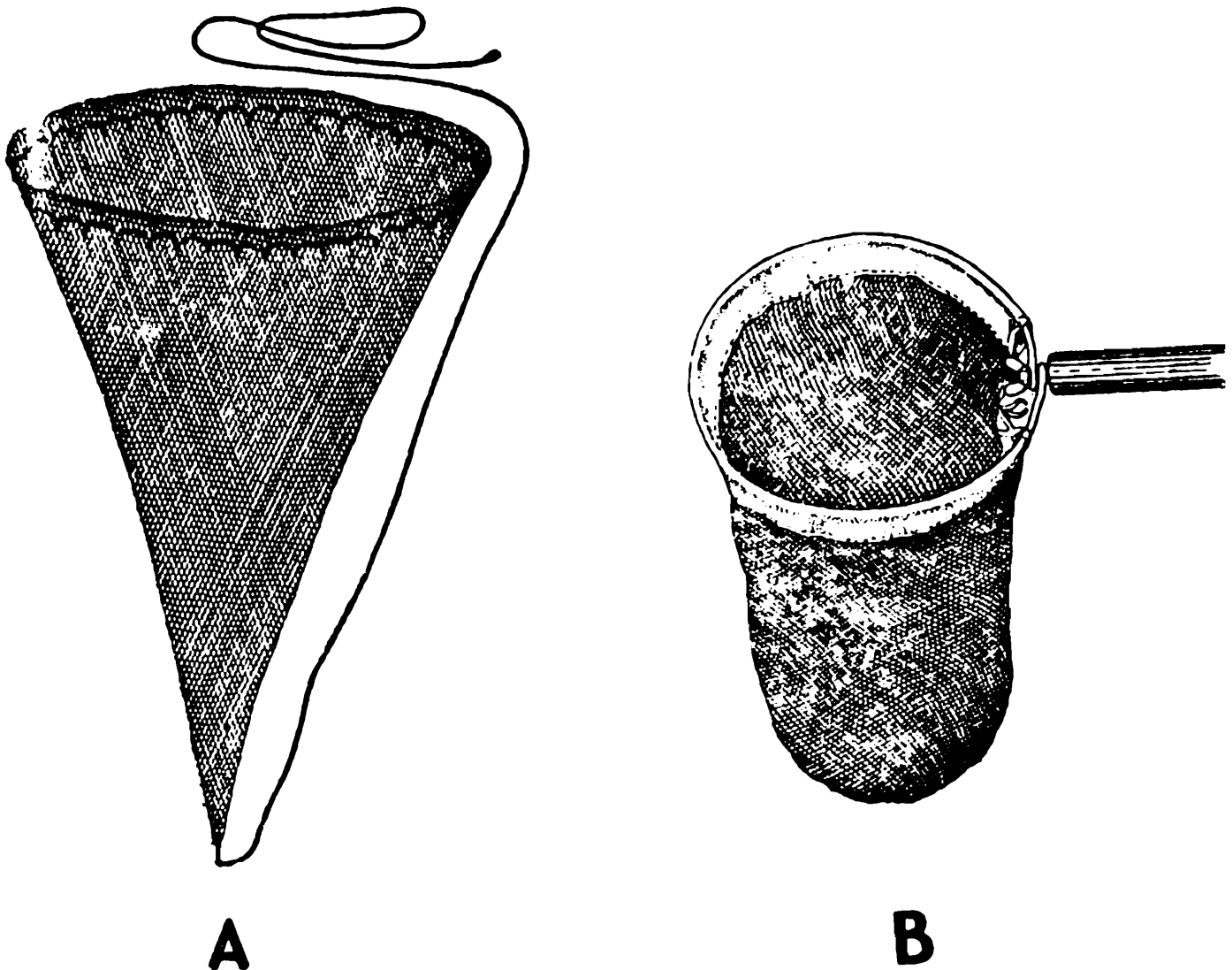

Collection nets
A. Cast net; B. Bag net

Amphibia

Class Amphibia is divided into three Orders : Caudata comprising of tailed salamanders, Gymnophiona comprising of limbless caecilians, and Salientia (Anura) comprising of frogs and toads.

Salamanders are completely aquatic, caecilians are rare, secretive and usually found under litter, logs or under stones in small streams. Frogs are aquatic, or semiaquatic, arboreal or burrowing, and toads are usually terrestrial.

Collection

The aquatic forms are collected by an ordinary water net fixed on a long handle. Terrestrial forms are caught by hand or net. Arboreal forms are difficult to be located because of camouflage. Tree trunks, leaves and tree holes and bushes should be searched for these. Burrowing forms have to be dug out from under the soil. They could be located by the help of faint tell-tale marks left on the soil surface.

Collecting should be done both during day and night. Nocturnal forms are easier to be caught when blinded by a torchlight or a petromax light.

Males of frogs and toads could also be located by their call which is often ventriloquial.

Tadpoles are collected with the help of a water net or by hand. Though they are found almost always in either stagnant or running water, tadpoles of some species (eg. *Rana beddomii*)

are found only on the moist surface of rocks where they grow and metamorphose. Care should be taken to collect the various stages of tadpoles including two-legged, four-legged and metamorphosed ones. This will help in fixing the identity of the tadpole.

Since the colour of the specimens is lost by preservation it is important to note the colour in live state. Shape of the pupil and the exact habitat should also be recorded in a field note book. Colour photos will be very helpful. Gyrating the live specimen in a polythene bag would quieten the specimen for taking photographs.

Articles required for collection and preservation

A 30 cm long and another 12 cm long forceps, a pair of scissors, polythene bags, absorbent cotton wool, a water net with long handle, chloroform, ethyl alcohol, formaldehyde solution, 5 litre plastic containers with handle, Jerry cans, a torch or petromax, thread and labels and a note book.

Small specimens can directly be put into cans containing 4% formaldehyde solution. A small incision on the abdominal wall would ensure better fixation of viscera. Larger ones should be chloroformed and 6% formaldehyde solution injected into the visceral cavity and preserved. Individual specimen should be wrapped in cotton wool in a desired position for setting. The specimens may be transferred to fresh 45% formaldehyde solution or rinsed well and preserved in 70% ethyl alcohol. Stronger alcohol would make the specimen shrink considerably. Caecilians are better preserved straight. The number and disposition of the various rows of teeth in the buccal cavity

being of taxonomic significance, it would be desirable to keep the mouth open by the help of a cotton plug or cork piece.

Labelling

Permanent labels giving date of collection, locality, altitude, name of collector, and habitat should be given to each adult which should correspond to entries in the field book. The labels should be of good quality paper, written with Indian ink. The field number should correspond to the number in the field note book. Short ecological features of the collecting locality should also be given. Tadpoles may be grouped into lots.

Packing for despatch

After fixation, the specimens, may be wrapped in cotton soaked in 4% formalin. These may be transported in polythene bags tied with thread in Jerry cans. In the laboratory they may be stored in 4% formalin, with labels tied securely on the legs.

Reptilia

Reptiles, in India consist of turtles and tortoises, crocodiles, lizards and snakes.

Collection

Tortoises and turtles : Turtles and tortoises, are amphibious creatures. They live in freshwater, in seas and oceans, in muddy habitat and on land. Smaller forms can easily be collected by means of a hand net, whereas larger forms by large nets, shooting or harpooning.

Killing of a turtle or a tortoise is a very difficult job and the following methods may be adopted.

i) A blow of a hammer delivered on to the neck to break the cervical vertebrae, ii) by injection of strong formalin or strong solution of chloral hydrate in the body cavity by a hypodermic syringe, or iii) by introducing a wad of cotton soaked in Prussic acid (Hydrocyanic acid) into the retracted cloaca of the animal.

Crocodiles : Crocodiles are also aquatic forms, and come on land for basking or catching domestic animals. Like turtles and tortoises, smaller specimens can be easily netted and the larger ones can be collected by shooting or harpooning. Trapping is hardly possible.

Lizards : Those with diurnal habits can be trapped as well as netted. In case of fast runners, shooting by means of dust

shot may be resorted to. Cryptozoic and nocturnal lizards can be collected by raiding their haunts.

Snakes : Snakes can be collected by killing them with a flexible cane. A smart blow on the spine just below the head may be delivered to break the spinal cord. Larger ones may be shot.

Live specimens of lizards and snakes may be killed by exposure to chloroform vapour.

Articles required for collection and preservation

The following articles will be found useful.

Metal covered large syringes fitted with hypodermic needles; hammer and chisel; hack saw with blades; shotgun with ammunition; rubber gloves; nets; a measuring tape, about 10 m long; a pair of fine pointed dividers; a pair of dissecting scissors with about 6 cm long blade; a pair of dissecting forceps, about 12 cm long; a pair of forceps, about 25 cm long; a pair of bone cutters; empty Kerosene oil or biscuit tins; chloroform; formalin; ethyl alcohol; absorbent cotton wool; a scalpel with 4 cm long blade; a scalpel with about 6-7 cm long blade; arsenical soap; common salt.

Preservation

The most essential thing for good preservation is that the fixative or preservative should reach to each of the organs of the body of an animal. This is sometimes achieved by injecting the fluid by a hypodermic syringe.

Tortoises and turtles : For smaller specimens, 8%

formaldehyde solution is injected into the body in sufficient quantity till it starts oozing out of the mouth. Then the specimens are dipped in 4-5% formaldehyde solution for two or three days. For larger specimens, incisions may be given in the axilla and groin regions to allow the fluid to gain access to the organs. Soft shelled turtles may first be preserved in formalin by the above method, and after a few hours washed in water and then transferred to 90% ethyl alcohol. By this procedure the colour pattern of the body will be retained. Large specimens are skinned, treated with arsenical soap and preserved dry.

Crocodiles : Juvenile specimens, not exceeding 30 cm, may be preserved in 90% ethyl alcohol, after making an incision on the belly. Larger specimens are preserved dry. For this the body of the animal is placed upon its back and an incision is made on the skin of the belly in midline. It is extended forward up to the lower lip and backward to the tail-tip. This is followed by four cross cuts from the median line to each of the limbs down to the toes. The skin is taken out from the body except the soles which remain intact with the skin. The skin is cleaned of all fat and flesh and dried in sun for further processing in the laboratory. Before this, common salt is rubbed throughout its inner surface. The skull and the skeleton are cleaned and preserved dry.

Lizards : Small specimens of lizard are preserved direct in 90% ethyl alcohol. For medium sized specimens, an incision is given in the belly before immersion in ethyl alcohol. For large specimens, the gut is removed from the body and the specimen is immersed in 4-5% formaldehyde solution or 90% ethyl alcohol. Sometimes the large specimens are skinned and preserved dry.

Snakes : Snakes can be preserved in the same way as the lizards. Care should be taken in handling freshly killed poisonous snakes. Dried skins are not suitable for taxonomic purposes.

Labelling

Each specimen should be labelled properly. A specimen is assigned a number against which fuller description is entered in the 'Station Book'. The label should preferably be made of handmade or cartridge paper, and should contain essential data such as, exact locality, date of collection, name of collector, etc.

Field notes with ecological observations, colour of the specimens or any other important data useful in identification should be entered in the Station Book.

If there are many specimens in a bottle, the label should be tied to the right leg of each specimen. However, if there is only one specimen a label may be kept inside the bottle.

Packing and despatch

The preserved specimens should be wrapped in cotton wool, and kept in a Kerosine oil container, containing 4-5% formaldehyde solution or 90% ethyl alcohol. The container should be soldered properly before it is despatched.

Aves

For taking samples of birds for preservation, they should be located first. To do this, every type of habitat in the area of activity should be scanned. Birds, as is well known, can be found in practically every conceivable type of habitat such as in and around human habitations, forests, road-sides, in or near water-bodies, mud-flats, etc. Diurnal birds are best collected during early morning and late afternoon when these birds are most active. Crepuscular and nocturnal birds such as the nocturnal birds of prey (owls and owlets), nightjars and frogmouths, etc., can be collected from their feeding ground at night or from their diurnal roosting sites during day-time.

Collection

Depending on the location of the habitat, and the relative abundance and activity of the birds, samples of birds can profitably be collected either with mist nets or with firearms. Various types of indigenous traps are also used for collecting birds.

Mist nets

After the advent of mist nets in India, these have become the most popular instruments for capturing birds. If suitably placed, mist nets can be used for catching birds in large numbers, and if taken out quickly and carefully from the net, birds caught are not even injured. Of the several varieties of

mist nets* that are available, the ones manufactured by M/S Ohmi Netting Co., Ltd., Maibara, Shiga-Ken, Japan, from nylon threads, are widely used. Terylene threads are also used in the construction of mist nets.

Depending on the length, depth, number of tiers, mesh-sizes and thickness of twines used, several types of mist nets are available which can be used for catching birds ranging from small sized warblers to larger ducks. However, the most usually used type of nylon mist net for catching birds is the one which is 20 feet (c 6.1 m) in length and 9 feet (c 2.8 m) in depth with 4 tiers having 1 inch (c 2.5 cm) [1.5 inch (c 3.8 cm) in the extended condition] mesh-size and made of 2-ply black twine.

A mist net can be set up with two bamboo or aluminium poles. It can also be set up by tying the ends to suitable parts of trees or shrubs so that birds cannot struggle free or bounce off. Birds that do not detect and/or cannot avoid the net strike it and fall in a pocket created from the excess webbing. Birds entangle themselves further in the net when they struggle.

Entangled birds should be removed from the net as soon as possible, to prevent damage to the net and injury to the birds.

While removing a bird from the net, care should be taken not to damage the net or the plumage of the bird. Utmost care must be taken at the time of removal of a bird with sharp talons or claws and/or powerful beak, to prevent personal injury. The usual method of removal of a bird from the net

* Mist nets are not manufactured in India, and have to be imported.

should be observed — the toes are to be freed first, then the wings, and finally the head should be freed from the net. The body of the freed bird should be held under the palm of the left hand, the index finger and the middle finger passing by either side of the neck, the legs being held together with the help of the thumb, ring finger and the little finger. The bird should now be placed in a cloth bag which should be securedly tied with a string. The bag should be spacious enough so as not to damage the plumage, especially the tips of the wing- and tail-feathers. The cloth to be used for stitching bird bags should be of good quality and with fine perforations to allow enough air inside for breathing of the bird.

Firearms

Shotguns of various bore-sizes are used for collecting birds with firearms. A 12-, 16- or 20-bore and a .410-bore shotgun, and a .22 bore rifle are generally used. Cartridges loaded with Nos. 3 or 4 and 8 or 9 shots and .22 bore bullets and shot cartridges cover most needs. The larger bore guns are used for taking larger specimens and/or from long range while the smaller bore gun is used for smaller birds and/or from close range. Shot Nos. 3 or 4 are meant for larger birds, and Nos. 8 or 9 for smaller ones. 'Dust shot' or No. 12 and .22 bore shot cartridges are most useful for very small birds.

Articles required for preserving birds

A scalpel with about 4 cm. long blade; a pair of dissecting scissors with about 6 cm. long blades one of which is with pointed end and the other with rounded end; a pair of dissecting forceps with pointed ends, about 12-13 cm. long; a pair of long

forceps with rounded ends, about 25 cm. long; a kitchen knife; a pair of bone cutters; a pair of cutting pliers; galvanized iron wire, 11, 16 or 18, 20 or 22 gauges; smooth, straight sticks, such as bamboo splinters, of various lengths and thicknesses; a toothbrush; ordinary sewing needles (assorted); cotton sewing thread, Nos. 8, 60 and 90; a hoghair brush (round), No. 8, as used by artists; a 10 or 20 ml. metal-covered hypodermic syringe, with stout (No. 1, 2, 8, etc.) needles; a medium-sized carborandum hone; chloroform; formalin (38 - 40% solution of formaldehyde); rectified spirit (95 - 96% ethyl alcohol); common salt; benzene or carbon tetrachloride; heavy magnesium carbonate (Magnesium Carbonate Pond), magnesium oxide or coarse, clean and dry sawdust; arsenical soap**; teased non-absorbent cotton wool; absorbent cotton wool of very good quality with long fibres that can be easily peeled into thin layers; toilet tissue paper (3 to 4 folds) or old newspapers.

Preservation

From the moment a bird is shot, it should be treated very carefully. Blood and dirt from the plumage should be wiped off

** To prepare arsenical soap, 1 kg. of soft soap, such as 'SUNLIGHT', is to be cut into small bits. A little water is to be added to the bits of soap and melted over a low fire. 250 g. of white arsenic (= arsenic trioxide) and 63 g. of borax are to be added to the melted soap. The mixture is to be boiled for a few minutes, stirring all the time. It should now be removed from the fire and 32 g. of camphor should be added to it, stirring continuously until it cools. The consistency of arsenical soap depends on the amount of water initially used for melting the soap. By adjusting the amount of water, the arsenical soap may be made thick enough to solidify into cakes.

with bits of cotton wool. The throat and cloaca should be plugged with cotton wool. Colours of soft parts, especially of the iris which in many species of birds changes soon after death, should now be noted. The specimen of bird should be wrapped in a piece of tissue paper or old newspaper so that the plumage is not disturbed. Specimens should be thus carried to the field laboratory.

Preparation of study skins

Throat and cloacal plugs of cotton wool should be replaced with fresh plugs. The specimen should now be placed on its back and the feathers down the middle of the breast should be parted. A longitudinal incision through the skin from about the middle of breast to vent is to be made with a scalpel, taking care not to cut the abdominal wall. The skin from flesh is to be separated with fingers or handle of scalpel, and the same should be continued until the knee-joint is bared. The exposed flesh is to be kept dry by frequently dusting with magnesium carbonate, magnesium oxide or sawdust. Freed knee-joints should now be severed one after another. The skin round to base of tail should be separated. The tail should now be severed at its base with a pair of scissors or a scalpel, taking care not to cut bases of tail-feathers : a good bit of flesh and bones of tail may be safely kept with the skin. Freeing of skin from body should be continued forward, turning it inside out. Skinning of the wings should be done in the same manner as has been done in case of the legs. Skinning should be proceeded forward till ears are reached. Skin of the ear-holes should be pulled out with fingernail or a pair of forceps. Proceeding a little anteriorly over the eyeballs, the thin transparent membranes which attach

eyelids to eyeballs should be severed, taking care not to cut the lids. Freeing of skin should be continued as far as the base of the bill. The eyeballs and the floor of the mouth-cavity, including the tongue, should be removed. The neck and body should be separated from the head by severing the back of the skull. The roof of the mouth-cavity also should be removed. The brain and the soft tissue from the skull should be cleaned out, as far as possible.

The skin is now completely inside out. The upper arm bone should be severed just short of elbow-joint and removed along with the flesh. The flesh from leg bones and base of tail should be removed, as far as possible. Arsenical soap should now be applied all over the inner surface of the skin as also on parts of bones where bits of flesh might still adhere, such as roof of mouth-cavity, base of tail, etc.

Leg muscles are to be made up with cotton wool wound round leg bones. Eye-sockets are to be filled up with cotton wool. The head should be turned back to its normal position, and in doing so, skin of neck should not be pulled. Now, the whole skin should be turned right side out. The wings are to be placed with their inner surfaces exposed. A longitudinal incision is to be made on the skin of forearm from elbow-joint to wrist. The skin is to be freed from the flesh and the flesh should be cleaned off from wing bones. Arsenical soap should be applied locally and the skin replaced so as to cover the bones. Forearm bones of one side should be tied with those of the other side by passing a string through the loop formed by these bones at the elbow-joint. The gap between them should be as much as it is in a natural state.

The skin of neck of a bird with narrow neck or large head (woodpecker, duck, etc.) cannot be drawn over the head. In such a case, the neck is to be skinned as far forward as can be easily done after which the neck should be severed. An incision should be made through the skin from the middle or back of crown to nape. The skull is to be turned out through this opening and cleaned. Arsenical soap is to be applied to the skull and be placed back to its original position after which the cut is to be sewn up. Mud and blood stains on the plumage, if any, should be removed with cotton wool soaked in clean water. Wet patches on the plumage are to be dried with liberal use of magnesium carbonate. The powder should then be shaken off from the plumage.

On a piece of wire or stick (pointed at one end) a little longer than the body of the bird, cotton wool is to be rolled tightly (tying from time to time with strong cord) so as to make an artificial body roughly similar in shape and size to those of the body which has been removed from the skin. The narrow end of the artificial body is to be passed up the neck and the whole 'body' is to be placed within the skin. The pointed end of the stick should be inserted into the back of the skull so that the head and the bill lie in the same line as the body. The skin should be arranged properly and small pieces of cotton wool should be packed wherever required to give a good shape to the bird. The projecting part of the wire or stick should be removed by cutting at the appropriate place. The leg bones should now be exposed and their heads passed through strings with which the body is tied. The base of the tail should be sewn into the artificial body by at least two stitches. The cut on the skin of the abdomen should now be finally sewn up. A

very thin solution of arsenical soap should be applied on bill, orbital skin, legs, feet, claws, pads, etc. The mandibles are to be tied together with a fine thread so that the bill remains closed. The legs are to be crossed and the toes should be extended moderately.

The string of a label is to be tied firmly at the crossing of the legs. Feathers are to be arranged so that they lie flat. Wings and tail should be placed in position. The specimen should now be wrapped in a thin layer of cotton wool, and laid aside in a shady, airy place for drying. Special care must be taken so that ants and other insects, rats, mice, dogs, cats, etc., may not have access to the specimen.

Determination of sex

The abdominal cavity of the body after it has been removed from the skin, is to be opened with a pair of scissors. Gonads which lie close to the backbone near the anterior end of the kidneys, are to be located. The male gonads are a pair of testes, smooth, globular, ovoid or elongated bodies, large during breeding season but quite small (and inconspicuous in small birds) in non-breeding period. The female gonad consists usually of a single (left) ovary which is an irregular mass of granular substance. During breeding season, the granules enlarge into globular ova of various sizes. The sex of the specimen is to be noted on its label.

Preservation of whole specimens

Specimens of birds are also preserved whole. Birds whose plumage and skin have been badly damaged to make them unsuitable for the preparation of study skins, are generally

preferred for preservation as whole specimens. For this, 75 - 80 % ethyl alcohol[§] or formalin solution of desired strength[@] is generally used both as fixative and as preservative. A liberal dose of the fixative-cum-preservative solution is to be injected into the abdominal cavity of the specimen. Alternatively, a large incision on the abdominal wall is to be made to expose the viscera. A label is to be tied to the legs of the specimen which should then be dropped in the same solution. If ethyl alcohol is used, it should be replaced with fresh alcohol after two or three days; for large and fatty birds, the preservative is to be changed two or three times. Initially, the volume of the fixative solution should be about 10 times that of the specimen.

Labelling

Every specimen must bear a label made up of good, strong and durable paper (preferably thick quality of 'SKOLAR' brand cartridge paper), approximately 8 × 2 cm. in dimensions, with a cotton string ('ANCHOR' brand mercerised cotton thread, No. 8 preferred) attached at one end. The following are the minimum data that should be entered on each label :

Locality of collection, followed by names of district and State.

[§] To prepare ethyl alcohol of this strength 80 parts of rectified spirit s to be diluted with 20 parts of clean water.

[@] To prepare formalin solution for the preservation of whole specimens of birds, 1 part of strong formalin (38 - 40 % formaldehyde solution) is to be diluted with 9 - 14 parts of clean water. Three tablespoonfulls of common salt per litre of the solution is to be added for better results.

Date of collection : the day of the month followed by first three letters of the name of the month, and year in full, (15 Mar 1988, but not 15.3.88).

Name of collector : only initials and the surname should be written; Dr., Shri, Mr., Km., etc., are to be avoided.

Sex of the specimen : '♂' for male, '♀' for female and '-' for a specimen whose gonads could not be examined.

Additional data on the size and condition of gonads (a sketch to size is most useful), colours of soft parts, etc., are also highly desirable.

All entries on the label should be made with soft lead pencil. Since the field label is never to be replaced, it should be written with utmost care.

Packing for despatch

Each individual study skin of bird should be wrapped in a piece of tissue paper or old newspaper. Study skins thus covered should now be placed in a strong card board box, with enough packing material in between the study skins, and sealed securedly.

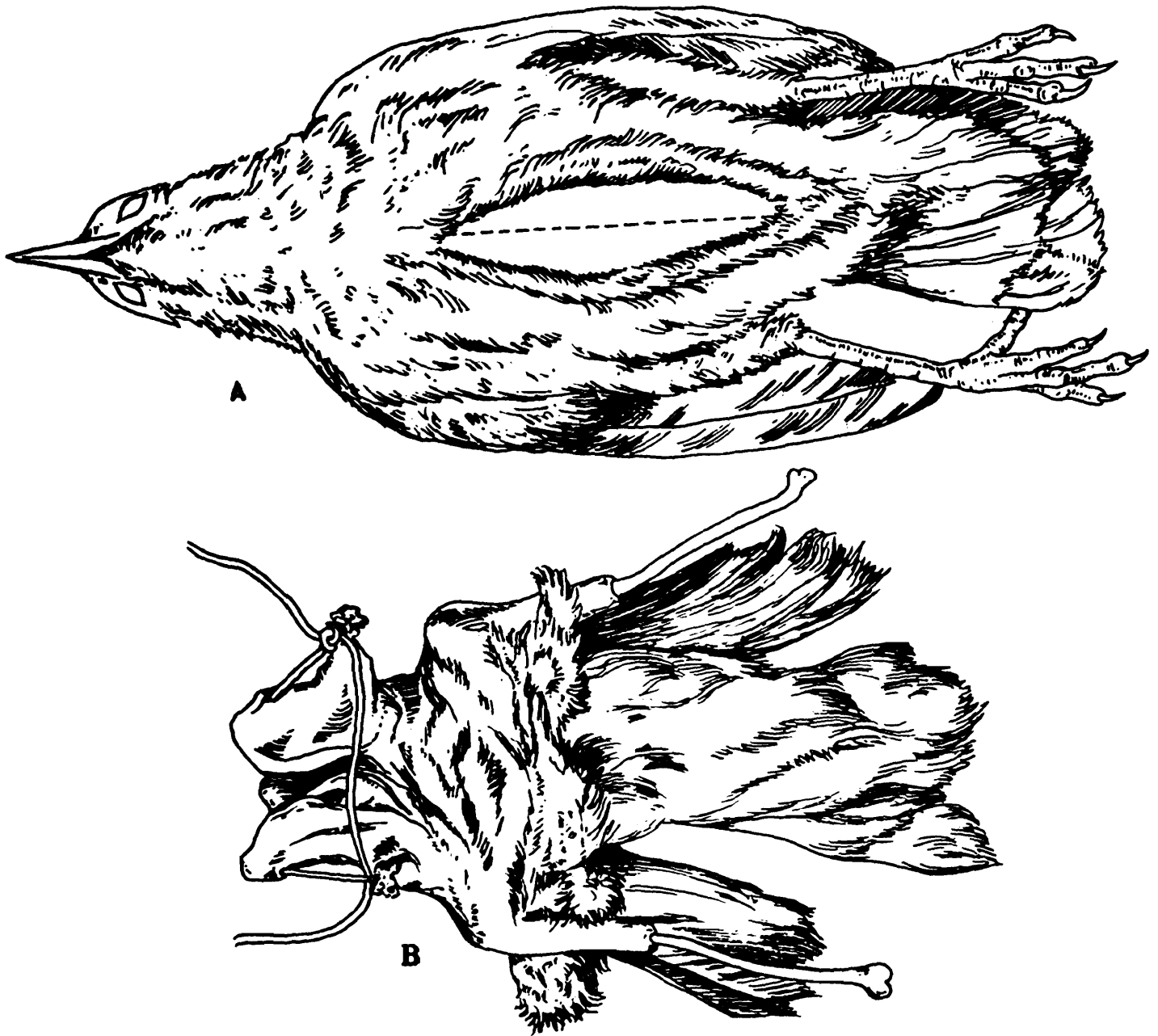

A. Line of initial incision (dotted) on the ventral side of a bird. **B.** Bird skin inside out, showing the method of tying the forearm bones.

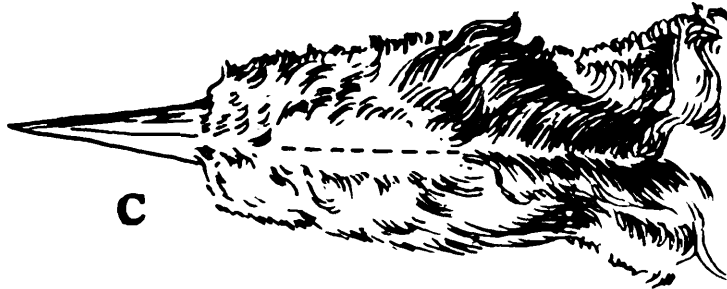

C

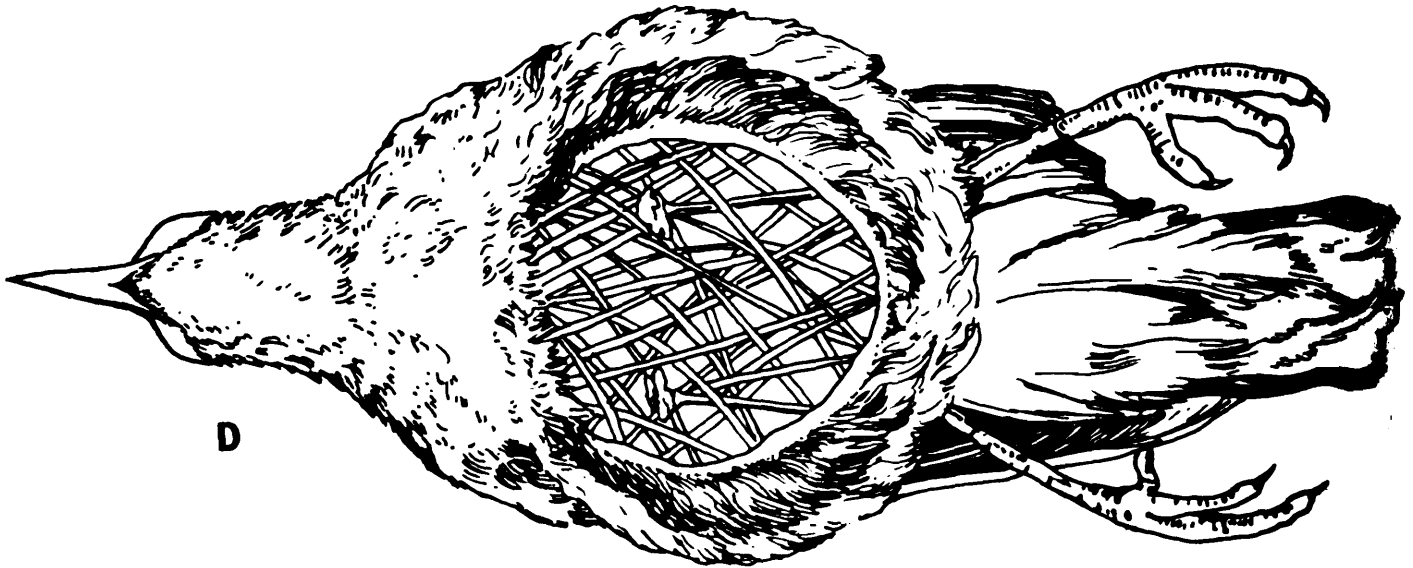

D

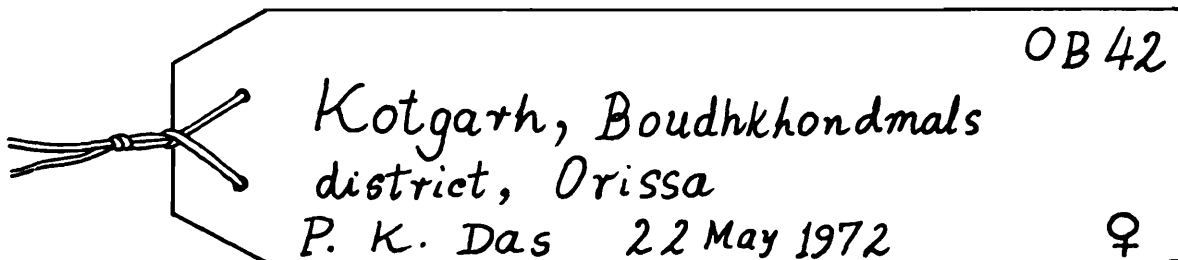

OB 42

Kotgarh, Boudhkhondmals
district, Orissa
P. K. Das 22 May 1972

♀

E

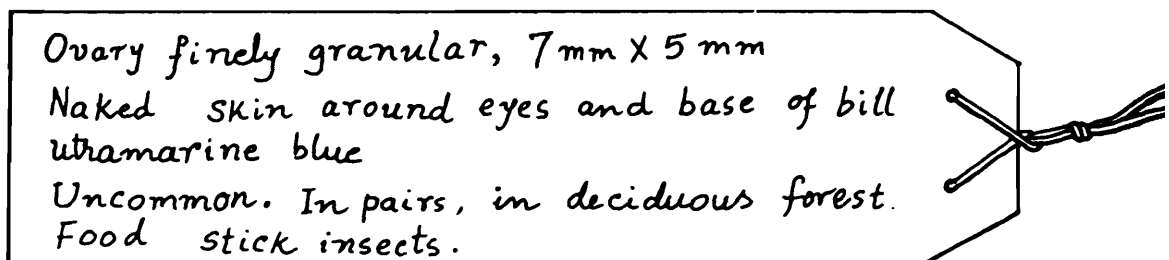

Ovary finely granular, 7mm x 5mm
Naked skin around eyes and base of bill
ultramarine blue
Uncommon. In pairs, in deciduous forest.
Food stick insects.

C. Line of incision (dotted) on the dorsal side of the crown of a bird with large head or narrow neck. D. Ventral view of a bird skin with artificial body inside, showing the positions of the heads of the leg bones before sewing up the ventral cut. E. Front (upper figure) and back (lower figure) of an ideal label for a bird skin.

Mammalia

Mammals range from tiny-sized shrews to gigantic whales and elephants. Scientifically, there is no such division as small, medium-sized and large mammals. For convenience, however, mammals below 30 cm in head and body length are called small mammals, between 30 cm and 100 cm as medium-sized, and above this size as large mammals. The method of collecting and preservation slightly differ in the three categories.

Collection

Specimens of mammals are usually collected with traps, nets and fire-arms. Each of the habitat types present in the area of operation, such as cultivated field, orchard, waste land, hillock, cave, forest, river-side, etc., is scanned by random sampling method. Generally, for diurnal species efforts are made during the day time and for crepuscular and nocturnal species in the evening and at night.

Traps

Numerous traps and trapping methods are available for collecting mammals. The kind of trap and the quality of bait to be used are selected with care depending on the animals sought. Traps should neither be too small nor too big for the anticipated catch.

Traps are broadly categorised into two types.

Snap or break-back trap : This trap is used for catching animals of the size of rats, shrews or small squirrels. This is

best suited for those animals which are trap shy. The only drawback in this trap is that the skull is occasionally broken. For this, the distance between the bait-pan and bar should be so adjusted that the bar may fall over the shoulders rather than on the head. Snap traps are often thrown some distance away when they go off, hence it is advisable to tie them to nearby vegetation with a string to prevent their loss.

Live trap : Live traps are used for catching animals alive. These are of two types.

- i) *Single catch trap* : These traps can catch only one animal at a time. Examples are wooden trap, Sherman trap, Japanese Wire trap, Weasel trap, etc. These are used for catching animals such as rats, mice, squirrels, mongooses, civets, etc., depending on their size.
- ii) *Multiple catch trap* : These traps can catch more than one animal at a setting. Examples are Wonder trap, Pitfall trap, Glue trap, etc. Wonder traps are good for catching commensal rodents and shrews. Pitfall traps are by far the most successful for catching small insectivores, like moles, pygmy shrews, *Crocidura* spp., etc., which are difficult to be trapped in any of the above-mentioned traps. Any type of wide-mouthed can, be just inserted in the soil in a pathway of the animal to be trapped, with its mouth in level with ground. The animal simply falls in it and cannot crawl out of it. The depth of the trap has a direct bearing on the size of the animal trapped. Glue traps are good for catching commensal rodents and insectivores. The animal gets entangled in the glue.

This trap is not suitable for catching animals for taxonomic study as the skin gets spoiled at the time of removal from the trap.

The success of any trapping operation is enhanced with a suitable bait. The bait should be freshly used. The use of some aromatic substances such as peanut butter, *ghee*, mustard oil, etc, and exotic food give better results. Some of the commonly used baits are roasted nuts, cheese, bread and butter, *pakora*, roasted coconut, puffed rice with peanut butter, dry fish, meat, intestine of dead animals, etc. Pitfall traps are generally not baited.

The success of any trapping operation again is directly proportional to the number of traps used. Therefore, plenty of traps of different kinds should be set, maintaining a distance of about 5-10 m between two traps. Trapping should be ideally done for three consecutive nights/days, as the case may be, in each of the habitat types.

Trap-lines should be marked at the beginning and end to prevent loss of traps. Coloured tape is most commonly used as a marker and is tied to the nearest vegetation.

Nets

The use of mist nets has brought about revolution in the collecting of bats. These are usually constructed from nylon thread. The most widely used mist nets are 6 - 20 m wide and 2 - 3 m in height, with four or five tiers.

Bats that do not detect the net strike it and fall in a pocket created from the excess webbing. The bats entangle themselves further in the net when they struggle. Captured bat should be

removed as soon as possible in order to prevent damage to both the net and the bat. The taughtness of the net should be loose enough so that the bats cannot struggle free or bounce off.

In the forest habitat conventional mist nets can be hoisted from ground level to higher levels for collecting purposes. Nets may also be tied in front of the opening of caves or at any other places where bats are expected to occur.

Location of roosts : Prior to use of mist nets, acquiring specimens of bats was greatly dependant on locating roost sites. Roosts are generally associated with vegetation such as hollow trees, broad leaf foliage, palm fronds, holes in trees, internodal cavities of bamboo, under the loose bark of trees, inside unfurled banana leaves, etc. Building may shelter bats under roofs rafters, caves, corrugated metal roofing shingles, below tiles, door or window-sills, etc. Other habitats include ruined monuments and temples, sewers, culverts, tunnels, caves, crevices, fissures and bridge trusses.

The collecting of bats in roosting sites included capture by hand, picking by a pair of forceps, hand nets, special collecting bags on long poles or by the use of smoke.

Live bats are normally kept in cloth bags. The bags should be made up of fine cloth so that the bats may not become entangled in the threads and damage membranes. Moreover, there should not be overcrowding of bats in a bag. It may cause many bats to die because of suffocation.

Firearms

A .410 bore shotgun with cartridges having shot Nos. 4, 6, 8 and 9 is good for collecting small mammals from short

range. Dust shots may prove useful in collecting flying bats. A 12-bore shot gun with cartridges having shot Nos. LG, SG, SSG and 1 - 9 is good for collecting medium-sized and large mammals. However, one or more of sporting rifles (.558, .952, .698 cm, etc.) may be needed for collecting mammals from long range. Care should be taken that the skulls are not damaged.

Measurements

Live specimens are killed in the field laboratory by exposure to chloroform or ether vapour. If a specimen is killed in the process of collecting it is brought to the camp as early as possible before it rots.

Prior to preservation, the external measurements are taken and other data like weight (in grams), sex, number and position of mammae, condition of gonads, number of planter pads, etc., are noted.

External measurements are taken in millimetres from freshly killed animals with the body-parts fully relaxed. All measurements are taken as straight distance between two points of references. For mammals, the following four standard measurements are generally taken, with additional measurements according to research needs.

- i) Head and body length - from the tip of nose to the anus.
- ii) Length of tail - from the anus to the tip of tail vertebrae, excluding pencil of hairs, if any.
- iii) Length of hind foot - from the heel to the tip of longest toe, excluding claw.

- iv) Length of ear - from the intertragal notch to the farthest edge of pinna, excluding hairs, if any.

For measuring head and body length, the easiest method is to measure the total length of the animal from the tip of nose to the end of tail vertebrae and to subtract the length of tail from it.

In case of bats, additional measurements like the length of forearm, tibia, foot and claw, metacarpals, phalanges, and calcar, length and breadth of noseleaf and length of tragus, if present, are also taken. These measurements may be taken from either freshly killed animals or the processed ones.

If the specimen of a medium-sized or large mammal is to be mounted as a museum exhibit, its height and girth at various points should also be measured.

Preservation

The specimens are either preserved wet or dry. In both cases it is ensured that the specimen is not a rotten one. If perchance, a specimen is decomposed due to delay in preservation, it is converted into skeleton.

Articles required for preservation

A list of articles for the preservation of mammalian specimens is given below :

A metric rule, about 30 cm long, graduated in millimetres; a measuring tape, about 2 m long graduated in millimetres; a pair of fine-pointed dividers, about 12 cm long; a scalpel with about 4 cm long blade; a stout scalpel with about 6-7 cm long blade; a "Butcher's Knife"; a pair of dissecting scissors with

about 6 cm long blades one of which is with pointed end and the other with rounded end; a pair of dissecting forceps with pointed ends, about 12-13 cm long; a pair of long forceps with rounded ends, about 25 cm long; a pair of bone cutters; a pair of cutting pliers; galvanized iron wire, 18, 20 and 22 gauges; a small triangular file; a tooth-brush; sewing needles, Nos. 2-8; cotton sewing thread, Nos. 8, 60 and 90; a hog-hair brush (rounded), No. 8 as used by artists; a 10 or 20 ml metal covered hypodermic syringe with stout (Nos. 1, 2, 8, etc.) needles; a medium-sized carborandum hone; common salt; heavy magnesium carbonate (Magnesium Carbonate Pond) or Magnesium oxide or clean, dry, coarse sawdust; chloroform; formalin (38 - 40% aqueous solution of formaldehyde); ethyl alcohol (90-95%); arsenical soap (for its preparation, see page 206 foot note); teased non-absorbent cotton wool; absorbent cotton wool; large pins, preferably 'Hair' or 'Hat' pins - long steel pins with rounded glass, plastic or metal heads; soft wooden board or thermocol; old news paper or toilet tissue paper (3-4 folds) for carrying dead specimens and for wrapping prepared skins; psola spring balance 50 g, 100 g, and 500 g; a dial callipers.

Wet preservation

The popularly used word 'preservation' actually includes two distinct processes - fixation and preservation. Either one chemical in different concentrations is used for both the processes or separate chemicals are used for each one of them. Normally 10% formaldehyde solution (1 part 40% solution of formaldehyde and 3 parts water) or 90% ethyl alcohol is used as fixative and 4% formaldehyde solution (1 part 40% formaldehyde solution and 9 parts water) or 70% ethyl alcohol

as preservative. Sometimes the specimens are fixed in 10% formaldehyde solution but preserved in 70% ethyl alcohol. Since, formaldehyde solution is partially acidic in reaction, it is buffered with a little amount of common salt, chalk, borax or hexamine before use.

For proper fixing of the internal organs enough solution of 10% formaldehyde is injected into the abdominal cavity so as to somewhat distend it. Alternatively, the abdomen is slit open along the mid-ventral line to expose the viscera. The extent of incision varies with the size of the specimen. Some amount of absorbent cotton is pushed inside the abdominal cavity through the slit to facilitate the inflow of fixative. The specimen is then given the desired shape in an enamel tray and is kept completely immersed in formaldehyde solution of the above strength for about 24 hours or more depending on its size, the volume of the fixative is maintained at about ten times the volume of the specimen. After it is checked that the different body-parts of the specimen have been properly fixed, i.e. have become stiff, it is transferred to the preservative, which is either a fresh solution of 4% formaldehyde or 70% ethyl alcohol. However, if a specimen fixed in formaldehyde solution is to be preserved in alcohol, it is first thoroughly washed in running water, semi-dried, and then transferred to the latter. When the specimen is to be fixed in alcohol, the same procedure is followed as for the formaldehyde preserved specimen. The only difference is that the specimen is kept in 90% ethyl alcohol for a longer period i.e., for two or three days, and then transferred to 70% alcohol. For large, fatty specimen, the alcohol is changed two or three times.

In the field, the specimens preserved wet are separately

wrapped in absorbent cotton and stored in a large wide-mouthed polythene or copper container, having a solution of 4% formaldehyde or 70% ethyl alcohol. However, it should be ensured that each specimen has a label tied to it.

Dry preservation

In dry preservation, the skin of the animal is removed and treated with chemicals to fix the tissue.

Small mammals : The preparation of study skins of small mammals involves two processes - skinning and rolling.

Skinning : The animal is placed on its back. The fur along the mid-line of the abdomen is parted. The skin of the animal is cut with a scalpel longitudinally for about 2-3 cm. Care is taken not to open the abdominal cavity. The skin is separated from the flesh over the abdomen and then on each of the hind limbs, with the help of fingers, until both the knee-joints are exposed. After loosening the skin round the knee, the joint is severed. The skin is separated all round up to the base of the tail so that it can be grasped with two fingers. Magnesium carbonate is sprinkled on the inner surface of the skin to facilitate gripping. The skin is held on the base of tail by the left thumb and forefinger and the tail vertebrae are pulled out of the skin by the right hand. In some cases where the tail vertebrae cannot be pulled out easily due to injury, etc., the skin of the tail is cut length-wise at the place of obstruction and tail vertebrae freed. Freeing of the skin from the body is continued forward turning it inside out. On each of the forelegs, it is freed up to the elbow-joint and then the joint is severed, and freeing of skin is continued farther forward. The ears are cut as close to the skull as possible. The eyelids are freed from the

eyeballs, by the point of a scalpel. Further anteriorly, the skin is cut free at the nose by slicing it through the nasal cartilage. Extreme care is required to avoid damaging the cranium. Some bats have delicate protruding premaxillary bones and incisors. These bones as well as nasal bones should not be damaged. The skin is finally freed from the flesh by cutting it at the base of lips.

The skin over the forelimbs and the hindlimbs is inverted as far as possible and the flesh over the remaining portion of the bones cleaned off. The fat below the skin is scraped off. The soft tissue from the sole is removed as much as possible through a slit made in the middle of it.

The lips are sewed and the skin is turned fur-side out. The blood stains, if any, are cleaned with cotton soaked in cold water. If the skin is too dirty, it is washed in cold water with soft soap. The fur is dried by using magnesium carbonate. The skin is again inverted. Moist alum powder (alum pulverised) is rubbed throughout the inner surface of the skin. Some quantity of alum powder is also inserted inside the hollow tail-skin with the help of a wire. Soft parts like lips, base of ears, sole of feet, etc., are painted with arsenical soap. In case of small specimens like a mouse, the application of the arsenical soap on the inner surface of the skin serves the purpose, alum may not be used at all.

At present two methods are prevalent for keeping the processed skin. One is the traditional method in which the shape is given to the skin by filling cotton wool or sawdust inside it, and is termed rolling. The other method is to preserve

the skin flat by inserting a piece of card board of suitable size, inside it. Skins thus prepared are called study skins.

Rolling : A piece of galvanized wire of 18, 20 or 22 gauge (depending on the thickness of the tail) slightly longer than the tail is taken and one of its tips filed to make it pointed. Some cotton wool is twisted around the wire to make the structure approximately equal to the original thickness of the tail. A little arsenical soap is then smeared on it. This is now inserted into the tail-skin. The limb muscles are prepared by wrapping cotton wool around the limb bones. To provide additional support a wire is inserted in each limb so as to reach the longer toe. The skin is turned fur-side out. An artificial body, somewhat similar in size and shape to the original body is prepared with common wool and inserted within the skin. Little wisps of cotton wool are inserted in the spaces between the outer skin and the artificial body, especially below the eyes, ears, nose, etc., to give the skin a proper shape. After this, the cut on the abdominal portion of the skin is sewed.

Specimens other than bats are set on a piece of thermocol placing the limbs close and parallel to the body, the forelimbs pointing forwards and the hind limbs backwards. A thin layer of cotton wool is wrapped from the nose to the neck of the specimen so that the whiskers lie backwards along the sides, and the ears lie flat on the head. It should be mentioned that keeping the ears erect in rolled skins, no doubt, facilitate examination of both sides of the ear but is disadvantageous in storing and there is every likelihood of the ears being damaged. The specimen is left to dry in a shady, airy place. Fleshy parts like the lips and soles are painted with carbolic acid.

The positioning and pinning of a specimen of bat will determine its usefulness for research purposes. For example, the distal and proximal portions of the forearm, all the metacarpals and phalanges, calcar, attachment of wing membrane to hind foot, etc., should be exposed so that they may be measured. The practice of positioning one of the wings extended is discouraged, as it occupies more storage space, and the wings are very likely to be damaged. The wing membranes should be tucked under the proximal end of the forearm. Similarly, the thumb of the bat should always be turned down and pinned beside the next digit. If left extended, it is subject to breakage. The ears and the nose-leaf are given extra support so that these may dry in extended position.

In the second method, instead of making an artificial body with cotton wool, a piece of thin cardboard is cut to the approximate size and shape of the head and body of the animal. A thin layer of clean, combed cotton is wrapped around the cardboard body; thread may be wrapped around it to hold the cotton in place. The cardboard body thus prepared is now inserted into the skin. The fore and the hind limbs are folded over the cardboard on the ventral side and the tail is set straight. Each limb and the tail are then fixed in position by a loop of thread. The dried skin is separately wrapped in a thin sheet of tissue paper or a piece of newspaper.

Medium-sized and large mammals : These mammals are prepared flat in the field and are made up, if necessary, in the laboratory.

Skinning : The body of the animal is placed upon its back and an incision is made on the skin of the belly in mid-line. It

is extended forward up to the lower lip and backward to the tail-tip. This is followed by four cross cuts from the median line to each of the limbs down to the toes. The skin is taken out by separating it from the body starting from the edge of cuts. It is made free from the body except the soles or hooves, which remain intact with the skin. The limbs are disjointed at the base of hand or foot. For hoofed mammals, all soft tissues are removed from the base of hooves, and for mammals with fleshy soles, the skin is let loose up to the last digits of the toes and all the soft tissues removed.

For mammals with horns or antlers, a Y-shaped incision is given on the back of the head, each arm of Y leads to the base of the horn or antler. The skin is let loose round the nape through the longitudinal arm of Y, and is freed around the bases of horns through oblique cuts. It is convenient to disarticulate the skull (not the outer skin) from the carcass so that the skin can be worked out from the remainder of the head.

The lips must be opened to prevent the loss of hair. The inner mucous membrane is separated up to the bottom where the skin folds inside the mouth cavity. The ears are skinned all the way to their tips from the inner side. As the work proceeds the ear is inverted until it is inside out. It is not necessary to remove the cartilage from the front of the ear. The inside of the eyelids need to be opened to prevent the loss of eye lashes. A small cut parallel to the edge of the eyelid is made on the back of the eyelids but not through the skin itself. If there are large pads of tissue to the inside of the nasal skin and covering the base of whiskers, the tissue is removed carefully so as the whisker-roots are not damaged.

The skin is washed in cold water with soft soap. Fatty skin can be washed in warm water. Blood stains should not be allowed to dry; cool water is used to wipe out the stains, if any. Hot water is excellent for softening and removing coagulated blood by dabbing the dry clots with cotton wool and combing the hair.

Ample amount of common salt are spread evenly over the whole flesh surface of the skin soon after washing it with water. The salt is rubbed well into the skin. The ears, lips, eyelids, feet and skin-folds are well salted to get to the bases of hairs. The skin of the head, neck and legs are folded over the body skin and rolled up compactly with the hair side out. A major problem with salt is that it readily absorbs moisture from the atmosphere as well as skin. Consequently, after 24 hours, the resulting brine is removed from the skin surface and the skin resalted. It is kept for another 24 hours in folded condition. Then it is unrolled and dried in shade. When the skin is almost, but not quite, dry, it is folded to a convenient size with fur side in. The skin is brought to the laboratory for further treatment.

Tanning : After bringing the salted skin of medium-sized or large mammals to the laboratory, it is sent for tanning to be done by professionals.

Preparation of skull and skeleton

Skull : The skull of each study skin of mammal must be available for study. Hence, after the specimen is skinned, the skull is cut off from the carcass at the neck region and is either fully cleaned in the field itself (depending on the time available)

or is given a label with a number corresponding to that of its skin, and stored in a container, preferably in 70% ethyl alcohol.

For extracting the skull of a wet preserved specimen, a small incision is made between the two jaws on both sides of the head and the skin is gradually freed posteriorly up to the neck and anteriorly up to lips, with a scalpel. The ears are sliced off as close to the skull as possible and the eyelids cut over the eyeball. Further, the skin is cut free at the nose by slicing it through the nasal cartilage. The skull is cut off from the carcass at the neck region. After taking out the skull, a small ball of cotton, approximating to the size of the skull, is put inside the skin of the head, and the incision sewed.

For cleaning, the skull is boiled in water until the flesh becomes soft. If the muscles of a formaldehyde preserved specimen have become very stiff, a few pellets of caustic potash are added to the water. This softens the muscles. Care is taken that there is no over-boiling of the skull, which may cause disarticulation of bones. Now with the help of a pair of forceps and a scalpel all the flesh is removed from the bones. The thin layer of connective tissue needs to be scraped off. The brain is scooped out through the foramen magnum either with a piece of flat-tipped wire and repeated washing in water or by forcing water inside the cranium through a syringe. The skull is now thoroughly washed and dried. It is either tied to the skin or kept separately in a glass vial with a label bearing the same collection number as that of its skin.

The skull in medium or large sized mammals is detached and partially cleaned in the field. The eyes, tongue and major muscles are cleaned off and the brain scooped out. Now it is

preserved in 70% ethyl alcohol for further cleaning in the laboratory.

Skeleton : A specimen of small mammal to be converted into skeleton is generally stored in 70% ethyl alcohol in the field. In case of larger specimens, the bones are partially cleaned and dried thoroughly. These are finally cleaned in the laboratory.

Labelling

Every specimen must bear a label made of good, strong and durable paper, approximately 8 × 2 cm in size, with ANCHOR brand No. 8 mercerised cotton thread attached at one end. SKOLAR brand cartridge paper is suggested for the purpose. However, 'resistal' paper for dry specimens and 'syntosil' paper for wet specimens are also long lasting.

The label is tied to the right leg of the specimen. The string attaching the tag to the specimen should not be so short as to interfere with the positioning of the tag, or should not be so long as to get tangled with other specimens or their labels.

The following data are entered on each label with a good quality soft pencil.

- i) *Locality* — Name of the place of collection, approximate distance and direction from a well known place in the map, name of the district and state, latitude, longitude, and altitude above the mean sea level.
- ii) *Date of collection* — The day of the month, first three letter of the month, and year in full. The date of

collection means the date on which the specimen was actually killed.

- iii) *Name of collector* — The name of the collector of the specimen is entered on the label. Usually, prefixes like Mr., Dr., Major, Capt., etc., are dropped from the name of the collector unless it is essential to distinguish two persons of the same name.
- iv) *Sex and age* — ‘ σ ’ for male, ‘ φ ’ for female and ‘—’ for specimens whose sex could not be determined. The sex of the specimen is determined by examining its external genitalia. In case of doubt, however, it is advisable to examine the internal reproductive organs. The age of the specimen, e.g. suckling, immature, subadult or adult should also be noted.
- v) *Measurements* — Standard body measurements, namely length of head and body (H & B), tail (Tl), hind foot (Hf), and ear (E), and the weight (in gramme) of the freshly killed animal are noted.
- vi) *Additional data* — The collection number, serial no., number and position of mammae (axillary, anterior thoracic, posterior thoracic, anterior abdominal, posterior abdominal and inguinal), reproductive condition of gonads (mammae lactating or not, vaginal orifice open or closed, size and position of testes, etc.), number of foetuses in each horn of the uterus, relative abundance (common or rare), bait used, habitat, etc., are also noted.

Packing for despatch

Wet preserved specimens : Each wet preserved specimen having skull *in situ* is wrapped in a thick layer of absorbent cotton, soaked (but not dripping) in fresh solution of 4% formaldehyde solution or 70% ethyl alcohol, as the case may be. One or more such specimens are kept in a polythene bag. The open end of the bag is completely sealed by exposing it to a candle flame. This polythene bag containing the specimen(s) is finally packed in a strong card broad box with sufficient packing material and despatched.

Before sealing the polythene bag it must be ensured that each specimen bears a label, mentioning the serial number, exact locality from where the specimen was collected, date of collecting of specimen, its sex, weight and body measurements. However, the weight and body measurements are not obligatory.

Dry preserved specimens : The dry skins whether rolled or flat are wrapped in a tissue paper. Each specimen should bear a label. The skull of that specimen is kept in a glass or polythene vial with a label bearing the same serial number as that of its skin. Both the skin and the skull are now packed in a strong cardboard box.

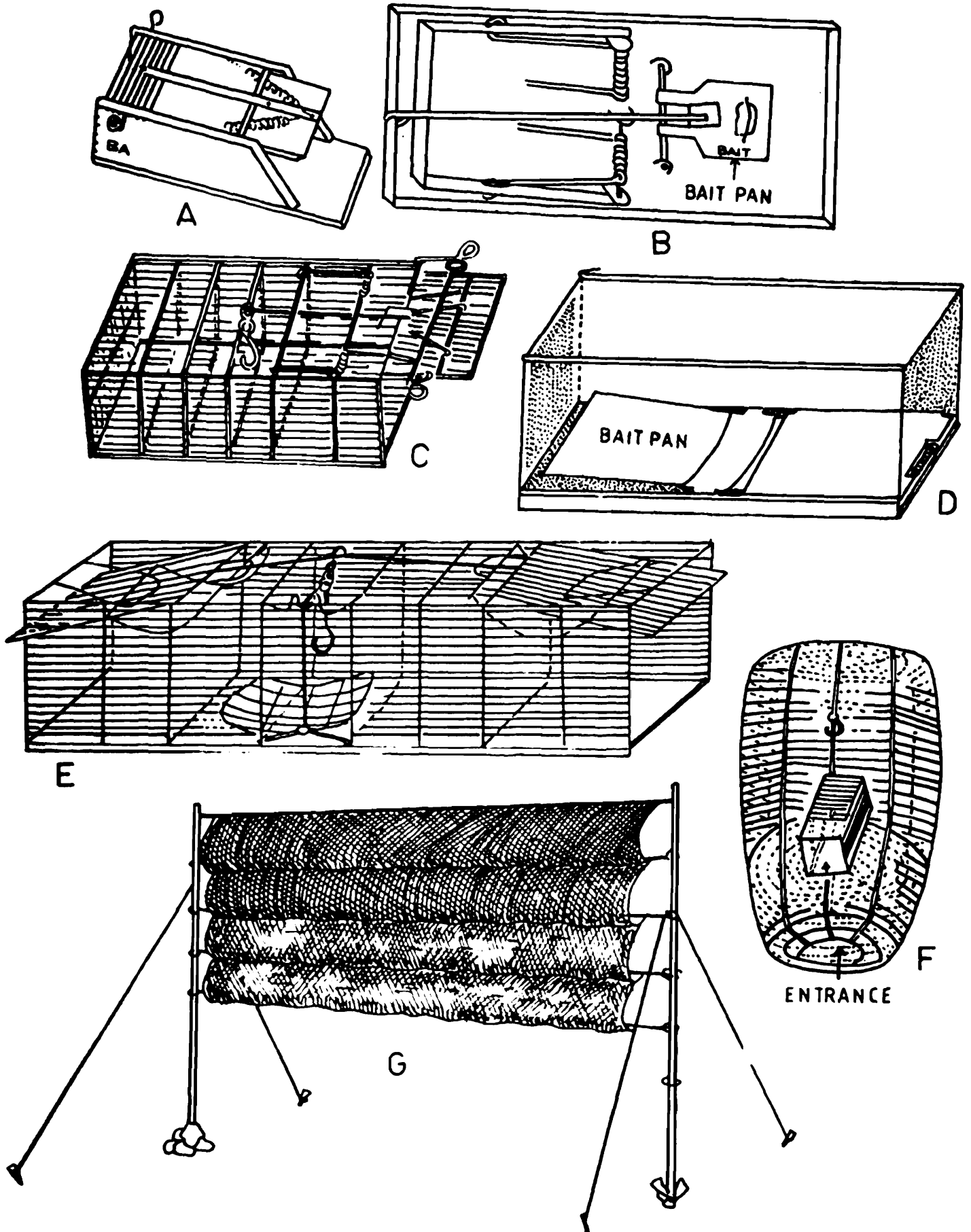
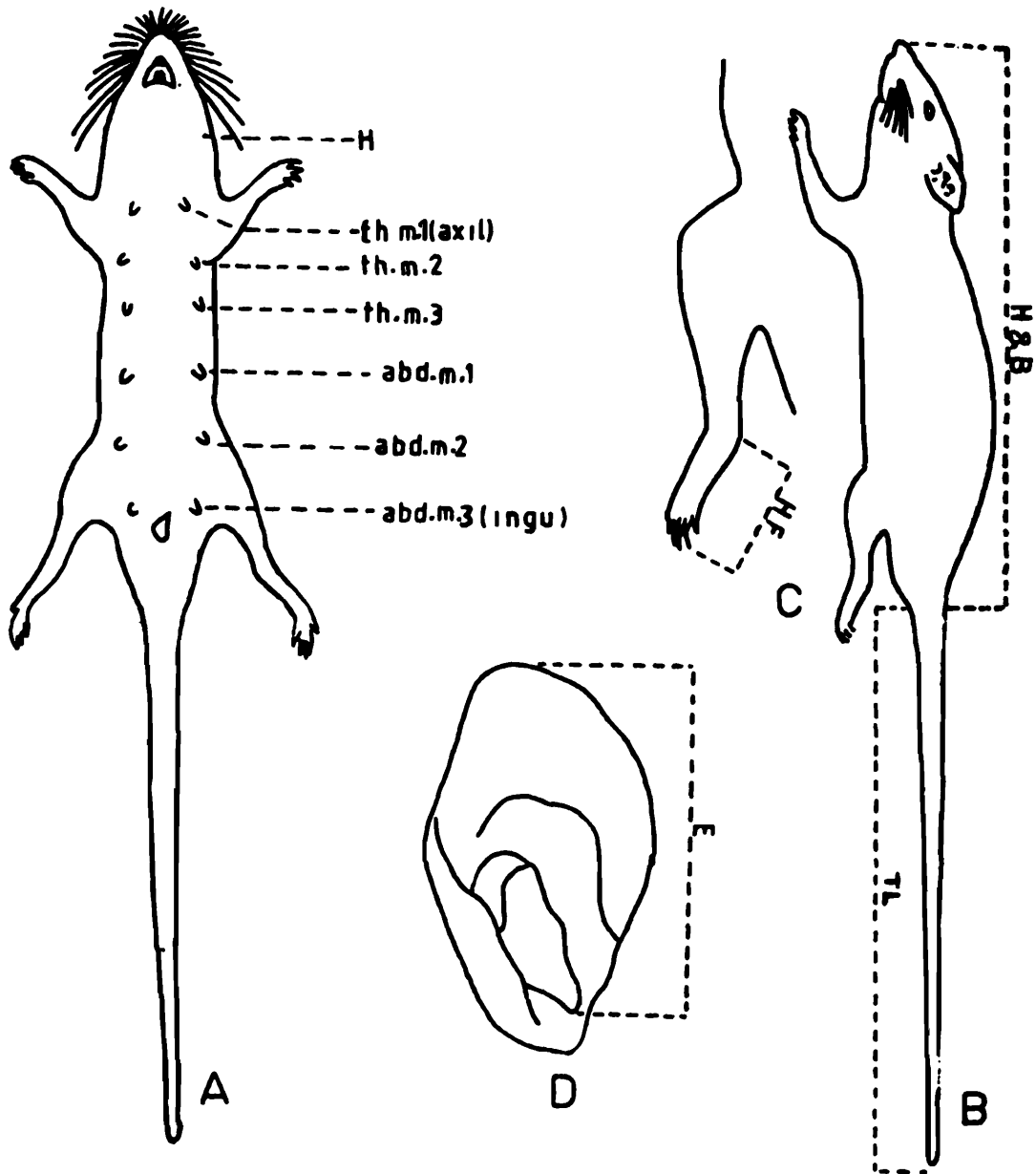

Plate 1. Different types of trap, and a mist net.

(A) Wooden trap; (B) Breakfast trap; (C) Japanese Wire trap; (D) Sherman trap; (E) Weasel trap; (F) Wonder trap (G) mist net in operation.



Siron (Grn Forest), 18km SE of Sagon. GFM33
 Junagadh Dist. Gujarat [21°5.70'N].
 V.C. Agrawal

E

MBB	154	Common in cultivated fields of
TL	174	wheat & millet.
Hf	35	Nocturnal.
E	21	Mammæ: 1+2 = 3 pairs
WT	170g	Grauid : 2 foetuses in right horn & 1 in left.

Plate 2. Ventral and lateral views of the body, hind foot, and ear of a small mammal showing position of mammae and different body measurements, as also the front and the back of a specimen-label.

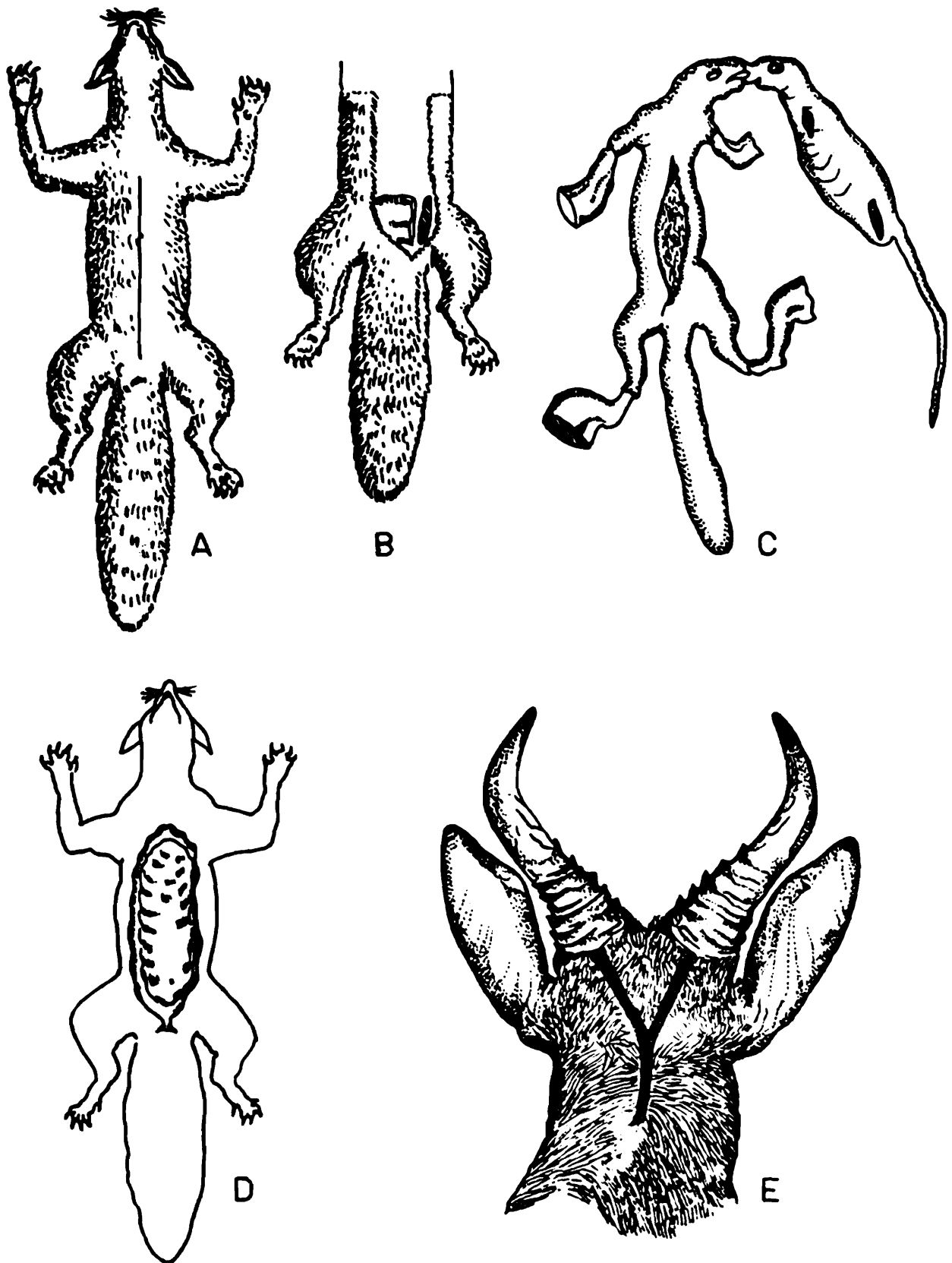

Plate 3. (A-D) Process of skinning and rolling of a specimen of small mammal; (E) Y-shaped incision to be given on the back of a horned mammal.

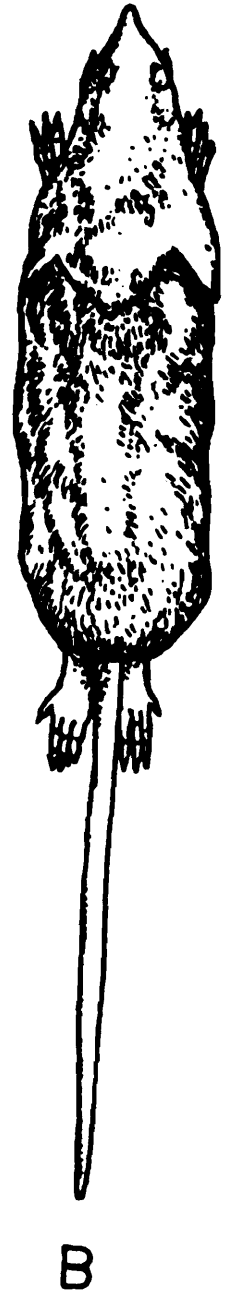
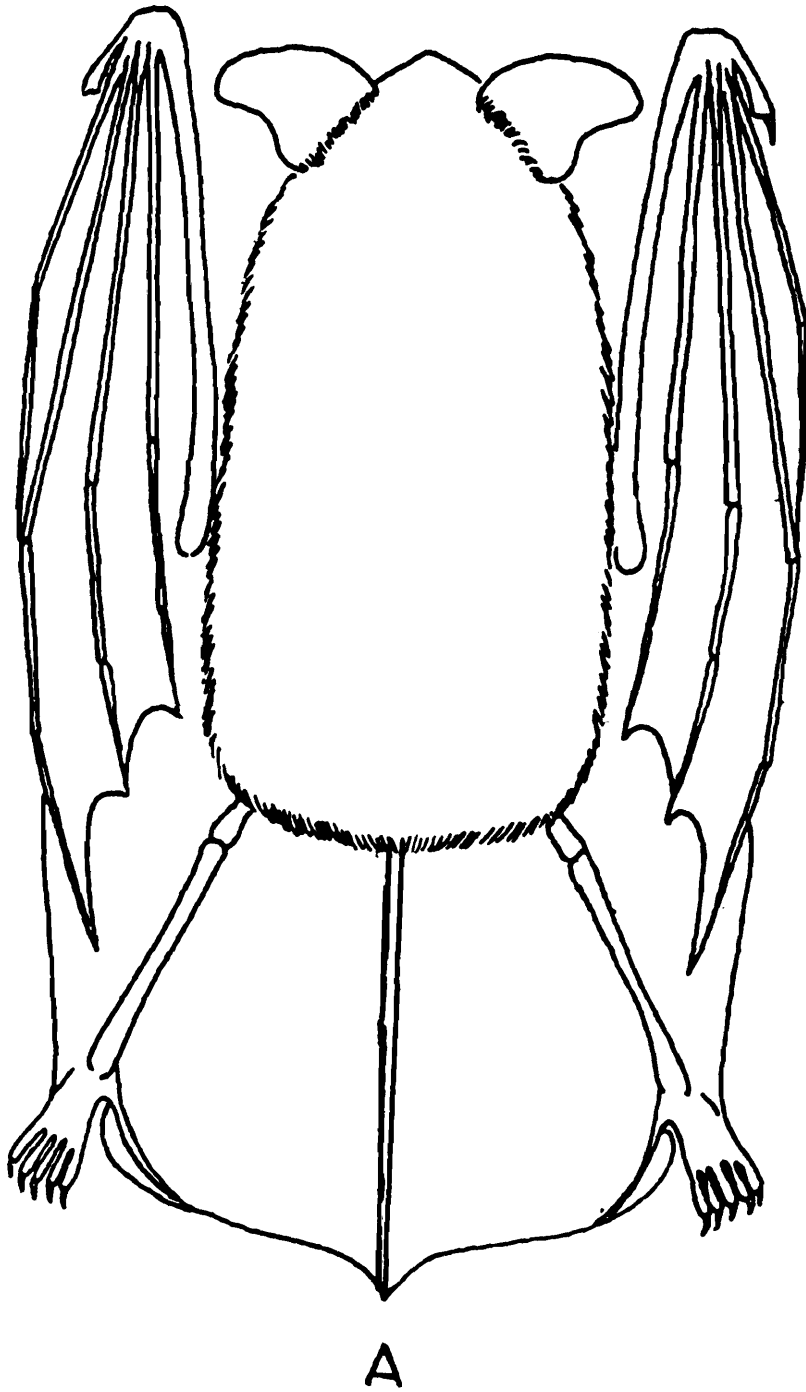

Plate 4. Complete study-skin of a bat (A) and a rat (B).

