

# *Fauna of India*

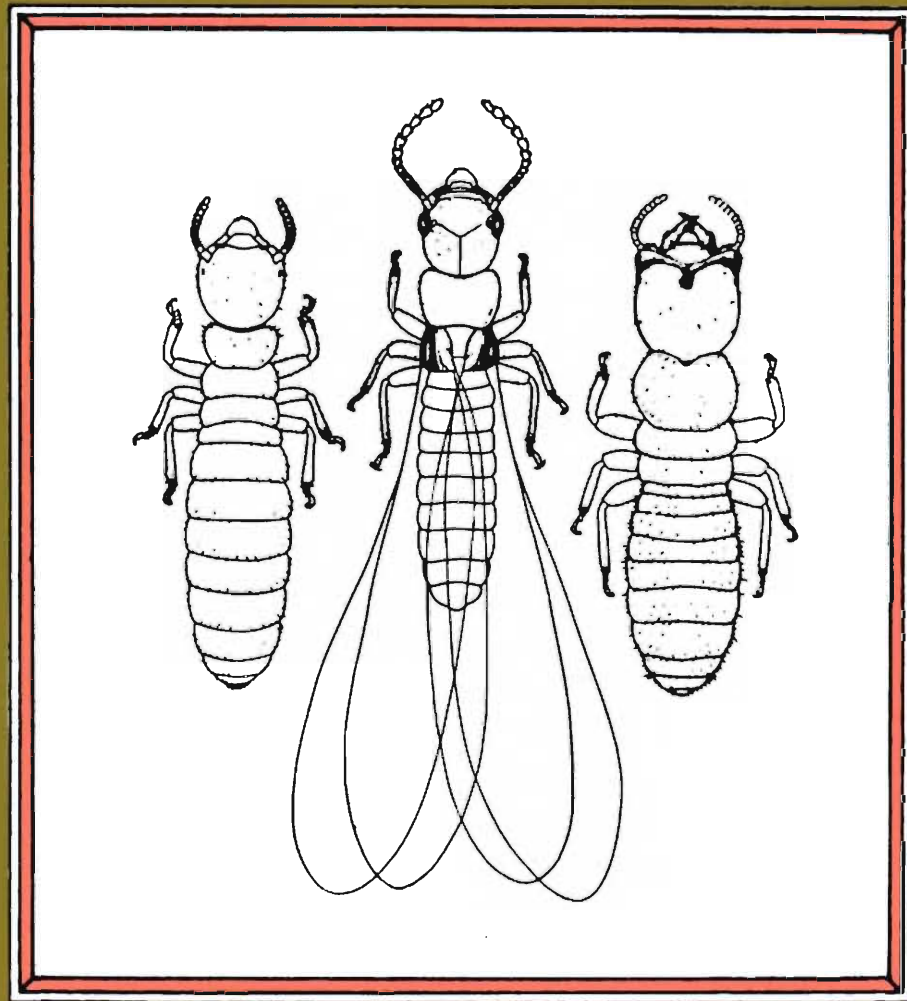

## **ISOPTERA (TERMITES)**

**Volume : I**

**M. L. ROONWAL  
&  
O. B. CHHOTANI**



This book forms volume one of the *Fauna of India, Isoptera* and covers the Indian Region. It deals first with the general introduction which includes a history of termite taxonomy, the characters used for differentiation of the species and genera, the methods of measurements of termites, the classification used, etc. Also included are the characters and descriptions of the various genera and 98 species in the following six families : Termopsidae, Hodotermitidae, Kalotermitidae, Rhinotermitidae, Stylotermitidae and Indotermitidae. The various polymorphic castes in each species are described separately.

**THE FAUNA OF INDIA  
AND  
THE ADJACENT COUNTRIES**

**ISOPTERA (TERMITES)**

*Volume 1*

**(Introduction and Families Termopsidae, Hodotermitidae, Kalotermitidae,  
Rhinotermitidae, Stylotermitidae and Indotermitidae)**

*By*

**M.L. ROONWAL**

*Desert Regional Station*

*Zoological Survey of India, Jodhpur*

and

**O.B. CHHOTANI**

*Zoological Survey of India, Calcutta*

*Edited by the Director, Zoological Survey of India*

**1989**

**© Copyright, 1989 Government of India**

**Published September, 1989**

**Printed in India at Doon Phototype Printers, Dehradun and  
Published by the Director, Zoological Survey of India, Calcutta.**

## FOREWORD

Several groups of insects were included in the earlier volumes of Fauna of British India series (presently the Fauna of India series) and some even ran into second editions but the Isoptera (termites) were never attempted. Although this group is of great economic importance for agriculture, forestry, plantations and buildings, our knowledge of Indian Region fauna was limited. Extensive taxonomic work has been done in the last two decades on the Indian fauna and the time is, therefore, ripe for an account of Indian termites.

The group was assigned, a few years back, to Dr. M.L. Roonwal and Dr. O.B. Chhotani who have been actively engaged in Isoptera taxonomy for over twentyfive years. It is proposed to bring out the Isoptera Fauna in two volumes. Volume One, which is presented here, includes the general introduction and the families Termopsidae, Hodotermitidae, Kalotermitidae, Rhinotermitidae, Stylotermitidae and Indotermitidae. Volume Two will contain the last but very large family of higher termites, the Termitidae and we hope that it will not be too long before that too is ready.

Calcutta  
November, 1987

B.S. LAMBA  
*Acting Director*  
*Zoological Survey of India*

## PREFACE

Termites, commonly known as white ants, form an important group of insects, the order Isoptera. They cause extensive damage to agricultural crops, forests, plantations (e.g., tea, coffee, coconut, rubber, sugarcane, etc.) and attack both living and dead plants. They also cause serious damage to woodwork in buildings, timber and bamboo depots, furniture, etc. The annual losses so caused amount to millions of rupees. Control work is both difficult and expensive largely because the damage caused is often hidden from view (there are hardly any external signs indicating damage) and it is already gone too far when it is discovered. Control work is also handicapped by a lack of the correct identification of the species involved.

Out of about 2,000 different species of termites known from the world (they mostly inhabit the tropical and subtropical regions), about 300 are known from the Indian Region which for the present volume includes India, Pakistan, Nepal, Bhutan, Bangladesh, Burma and Sri Lanka. During the last two decades extensive taxonomic work has been done on the Indian Region termite fauna and large areas of the region have been surveyed fairly thoroughly. The time is therefore, now ripe for giving an account of the termite fauna of the Region in the "Fauna of India" series. It is proposed to complete the work in two volumes. Volume One which is presented here contains the general introduction and six families, namely, Termopsidae, Hodotermitidae, Kalotermitidae, Rhinotermitidae, Stylotermitidae and Indotermitidae. Volume Two will contain the last but very large family of higher termites, the Termitidae.

The presentation of the species descriptions presents special problems since termites are highly polymorphic and have 3 major castes, the reproductives, the soldiers and the workers, the last two being neuters and incapable of reproduction and since these castes differ greatly in morphological characters specially the head, the mandibles, the presence or absence of wings, etc., it is necessary to give at least 3 descriptions under each species. This number may in some increase because each caste may show further polymorphism.

November, 1987

M.L. ROONWAL  
O.B. CHHOTANI

## ACKNOWLEDGEMENTS

We are indebted to the various institutions for facilities to study the Isoptera collections under their charge. These are the Zoological Survey of India, Calcutta, the Forest Research Institute, Dehra Dun, the Indian Agricultural Research Institute, New Delhi, the British Museum (Natural History), London, the American Museum of Natural History, New York, the Zoology Museum, Cambridge University, Cambridge (England), the Zoology Museum, Stockholm University, Stockholm and the Wasmann Collection in the Natural History Museum, Maastricht (Holland).

We are obliged to the late Prof. Alfred E. Emerson of the Zoology Department, Chicago University, Chicago, not only for facilities to study the extensive world collection under his charge but also for gifting valuable taxonomic material; also to Dr. (Mrs.) Geeta Chhotani (nee Geeta Bose) for extensive assistance in the preparation of the manuscript.

November, 1987

M.L. ROONWAL  
O.B. CHHOTANI

## CONTENTS

<b>INTRODUCTION</b> .....	1
Definition of Isoptera .....	1
Brief History of Termite Study .....	5
Characters Useful in Taxonomy .....	7
Useful Characters from External Morphology.....	7
1. General .....	7
2. The Head .....	8
3. The Cervix or Neck.....	17
4. The Thorax and Wings.....	20
(i) The main sclerites .....	20
(ii) The legs .....	21
(iii) The wings .....	24
5. The Abdomen and Genitalia .....	39
(i) The male .....	41
(ii) The female .....	41
6. Chaetotaxy.....	47
7. Termite Measurements and Indices .....	50
(i) General .....	50
(ii) The more important measurements .....	52
(iii) The more important indices.....	53
(iv) Definitions of the more important measurements .....	54
(v) Definitions of the more important indices .....	72
Useful Characters from Internal Morphology .....	75
1. The Alimentary Canal .....	75
2. The Tergal and Sternal glands.....	76
3. Egg Size, Shape and Structure.....	76
(i) Size and shape .....	76
(ii) Structure .....	78
<b>Taxonomic Value of Secondary Structure</b> .....	80
<b>Polymorphism, Sexual Dimorphism and Sex Ratios</b> .....	81
1. Polymorphism.....	81
2. Sexual Dimorphism .....	84

3. Sex Ratios . . . . .	88
Biology and Ecology . . . . .	89
1. Life-history . . . . .	89
2. Habitats . . . . .	91
(i) Termite nests and mounds . . . . .	91
(ii) The wood-dwellers . . . . .	93
(iii) Temperature and humidity . . . . .	93
3. Inquilines . . . . .	94
4. Termitophiles . . . . .	94
Distribution and Zoogeography . . . . .	94
1. Distribution . . . . .	94
2. Zoogeography . . . . .	100
<b>SYSTEMATIC ACCOUNT . . . . .</b>	<b>105</b>
History of Termite Classification . . . . .	105
1. History . . . . .	105
2. Classification Adopted Here . . . . .	113
Diagnostic Characters of the Living Families of Termites . . . . .	114
Keys for the Identification of Living Termite Families . . . . .	119
1. Key to Imagoes . . . . .	119
2. Key to Soldiers . . . . .	120
3. Key to Workers and Pseudoworkers . . . . .	121
Descriptions of Families, Genera and Species . . . . .	122
<b>Family I. TERMOPSISIDAE</b>	
1. Characters of Family Termopsidae . . . . .	123
2. Distribution and Composition of Termopsidae . . . . .	124
<b>Genus 1. <i>Archotermopsis</i> Desneux</b>	
1. Characters of Genus <i>Archotermopsis</i> . . . . .	125
2. Composition and Distribution of <i>Archotermopsis</i> . . . . .	126
1. <i>Archotermopsis wroughtoni</i> (Desneux) . . . . .	126
<b>Family II. HODOTERMITIDAE Desneux</b>	
1. Characters of Family Hodotermitidae ( <i>sens. lat.</i> ) . . . . .	136
2. Distribution and Composition of family Hodotermitidae . . . . .	137
3. Keys to the Living Subfamilies of Hodotermitidae . . . . .	138
<b>Subfamily HODOTERMITINAE Desneux</b>	
1. Characters of Subfamily Hodotermitinae . . . . .	139
2. Distribution and Composition of Hodotermitinae . . . . .	140

<b>Genus 2. <i>Anacanthotermes</i> Jacobson</b>	
1. Characters of Genus <i>Anacanthotermes</i> .....	141
2. Distribution and Composition of <i>Anacanthotermes</i> .....	142
3. Keys to the Species of <i>Anacanthotermes</i> .....	143
2. <i>Anacanthotermes baluchistanicus</i> Akhtar .....	144
3. <i>Anacanthotermes macrocephalus</i> (Desneux) .....	147
4. <i>Anacanthotermes vagans</i> (Hagen) .....	155
5. <i>Anacanthotermes viarum</i> (König) .....	159
<b>Family III. KALOTERMITIDAE Froggatt</b>	
1. Characters of Family Kalotermitidae .....	168
2. Distribution and Composition of Kalotermitidae .....	169
3. Biology of Kalotermitidae .....	171
4. Keys to Indian Region Genera of Kalotermitidae .....	171
<b>Genus 3. <i>Postelectrotermes</i> Krishna</b>	
1. Characters of Genus <i>Postelectrotermes</i> .....	173
2. Distribution and Composition of <i>Postelectrotermes</i> .....	174
3. Keys to Indian Region species of <i>Postelectrotermes</i> .....	176
6. <i>Postelectrotermes bhimi</i> Roonwal and Maiti .....	176
7. <i>Postelectrotermes militaris</i> (Desneux) .....	179
8. <i>Postelectrotermes nayari</i> Roonwal and Verma .....	184
9. <i>Postelectrotermes pasniensis</i> Akhtar .....	186
10. <i>Postelectrotermes pishinensis</i> (Ahmad) .....	190
<b>Genus 4. <i>Neotermes</i> Holmgren</b>	
1. Characters of Genus <i>Neotermes</i> .....	192
2. Distribution and Composition of <i>Neotermes</i> .....	194
3. Keys to Indian Region Species of <i>Neotermes</i> .....	195
11. <i>Neotermes adampurensis</i> Akhtar .....	199
12. <i>Neotermes andamanensis</i> Snyder .....	202
13. <i>Neotermes artocarpi</i> (Haviland) .....	206
14. <i>Neotermes assmuthi</i> Holmgren .....	210
15. <i>Neotermes bosei</i> Snyder .....	214
16. <i>Neotermes buxensis</i> Roonwal and Sen-Sarma .....	220
17. <i>Neotermes dhirendrai</i> Bose .....	225
18. <i>Neotermes eleanorae</i> Bose .....	227
19. <i>Neotermes fletcheri</i> Holmgren and Holmgren .....	231
20. <i>Neotermes greeni</i> (Desneux) .....	236
21. <i>Neotermes kalimpongensis</i> Maiti .....	242
22. <i>Neotermes kemneri</i> Roonwal and Sen-Sarma .....	244
23. <i>Neotermes keralai</i> Roonwal and Verma .....	246
24. <i>Neotermes krishnai</i> Bose .....	248
25. <i>Neotermes mangiferae</i> Roonwal and Sen-Sarma .....	251

26. <i>Neotermes megaoculatus</i> Roonwal and Sen-Sarma .....	253
26a. <i>Neotermes megaoculatus megaoculatus</i> Roonwal and Sen-Sarma.....	253
26b. <i>Neotermes megaoculatus lakhimpuri</i> Roonwal and Sen-Sarma.....	256
27. <i>Neotermes microculatus</i> Roonwal and Sen-Sarma.....	258
28. <i>Neotermes nilamburensis</i> Thakur .....	260
29. <i>Neotermes paratensis</i> Sen-Sarma and Thakur.....	263
30. <i>Neotermes prosonneratae</i> Akhtar.....	266
31. <i>Neotermes shimogensis</i> Thakur.....	269
32. <i>Neotermes venkateshwara</i> Bose.....	271
Genus 5. <i>Kalotermes</i> Hagen	
1. Characters of Genus <i>Kalotermes</i> .....	274
2. Distribution and Composition of <i>Kalotermes</i> .....	276
33. <i>Kalotermes jepsoni</i> Kemner .....	276
Genus 6. <i>Glyptotermes</i> Froggatt	
1. Characters of Genus <i>Glyptotermes</i> .....	281
2. Distribution and Composition of <i>Glyptotermes</i> .....	282
3. Keys to Indian Region Species of <i>Glyptotermes</i> .....	284
34. <i>Glyptotermes almorensis</i> Gardner .....	286
35. <i>Glyptotermes arshadi</i> Akhtar .....	291
36. <i>Glyptotermes ceylonicus</i> Holmgren.....	293
37. <i>Glyptotermes coorgensis</i> Holmgren and Holmgren .....	296
38. <i>Glyptotermes dilatatus</i> (Bugnion and Popoff) .....	302
39. <i>Glyptotermes minutus</i> Kemner.....	306
40. <i>Glyptotermes nicobarensis</i> Maiti and Chakraborty.....	310
41. <i>Glyptotermes sensarmai</i> Maiti .....	313
42. <i>Glyptotermes teknafensis</i> Akhtar.....	315
43. <i>Glyptotermes tikaderi</i> Chhotani and Bose .....	318
44. <i>Glyptotermes tripurensis</i> Thakur .....	320
45. <i>Glyptotermes ukhiaensis</i> Akhtar .....	322
Genus 7. <i>Calcaritermes</i> Snyder	
1. Characters of Genus <i>Calcaritermes</i> .....	326
2. Distribution and Composition of <i>Calcaritermes</i> .....	327
46. <i>Calcaritermes krishnai</i> (Maiti and Chakraborty).....	328
Genus 8. <i>Incisitermes</i> Krishna	
1. Characters of Genus <i>Incisitermes</i> .....	332
2. Distribution and Composition of <i>Incisitermes</i> .....	333
47. <i>Incisitermes didwanaensis</i> Roonwal and Verma.....	334
Genus 9. <i>Bifiditermes</i> Krishna	
1. Characters of Genus <i>Bifiditermes</i> .....	337
2. Distribution and Composition of <i>Bifiditermes</i> .....	338

3. Keys to Indian Region Species of <i>Bifiditermes</i> .....	338
48. <i>Bifiditermes beelsoni</i> (Gardner) .....	339
49. <i>Bifiditermes pintoii</i> (Kemner) .....	344
Genus 10. <i>Epicalotermes</i> Silvestri	
1. Characters of Genus <i>Epicalotermes</i> .....	348
2. Distribution and Composition of <i>Epicalotermes</i> .....	350
50. <i>Epicalotermes pakistanicus</i> Akhtar .....	351
Genus 11. <i>Procryptotermes</i> Holmgren	
1. Characters of Genus <i>Procryptotermes</i> .....	354
2. Distribution and Composition of <i>Procryptotermes</i> .....	355
3. Keys to Indian Region Species of <i>Procryptotermes</i> .....	356
51. <i>Procryptotermes dhari</i> Roonwal and Chhotani .....	356
52. <i>Procryptotermes hunsurensis</i> Thakur .....	360
53. <i>Procryptotermes valerizae</i> Bose .....	364
Genus 12. <i>Cryptotermes</i> Banks	
1. Characters of Genus <i>Cryptotermes</i> .....	368
2. Distribution and Composition of <i>Cryptotermes</i> .....	369
3. Keys to Oriental Species of <i>Cryptotermes</i> .....	370
54. <i>Cryptotermes bengalensis</i> Snyder .....	373
55. <i>Cryptotermes domesticus</i> (Haviland) .....	378
56. <i>Cryptotermes dudleyi</i> Banks .....	384
57. <i>Cryptotermes karachiensis</i> Akhtar .....	390
58. <i>Cryptotermes perforans</i> Kemner .....	393
59. <i>Cryptotermes roonwali</i> Chhotani .....	397
Family IV. RHINOTERMITIDAE Froggatt	
1. Characters of Family Rhinotermitidae .....	401
2. Distribution and Composition of Rhinotermitidae .....	403
3. Keys to Subfamilies of Rhinotermitidae .....	404
Subfamily (i) PSAMMOTERMITINAE Holmgren	
1. Characters of Subfamily Psammotermitinae .....	406
2. Distribution and Composition of Psammotermitinae .....	408
Genus 13. <i>Psammotermes</i> Desneux	
1. Characters of Genus <i>Psammotermes</i> .....	409
2. Distribution and Composition of <i>Psammotermes</i> .....	410
60. <i>Psammotermes rajasthanicus</i> Roonwal and Bose .....	410
Subfamily (ii) COPTOTERMITINAE Holmgren	
1. Characters of Subfamily Coptotermitinae .....	416
2. Distribution and Composition of Coptotermitinae .....	418

Genus 14. <i>Coptotermes</i> Wasmann	
1. Characters of Genus <i>Coptotermes</i> .....	420
2. Distribution and Composition of <i>Coptotermes</i> .....	420
3. Keys to Indian Region Species of <i>Coptotermes</i> .....	420
61. <i>Coptotermes beckeri</i> Mathur and Chhotani .....	422
62. <i>Coptotermes ceylonicus</i> Holmgren .....	425
63. <i>Coptotermes emersoni</i> Ahmad .....	431
64. <i>Coptotermes formosanus</i> Shiraki .....	434
65. <i>Coptotermes gaurii</i> Roonwal and Krishna .....	441
66. <i>Coptotermes gestroi</i> Wasmann .....	445
67. <i>Coptotermes heimi</i> (Wasmann) .....	449
68. <i>Coptotermes kishori</i> Roonwal and Chhotani .....	457
69. <i>Coptotermes travians</i> Haviland .....	461
Subfamily (iii) HETEROTERMITINAE Froggatt	
1. Characters of Subfamily Heterotermitinae .....	468
2. Distribution and Composition of Heterotermitinae .....	470
3. Keys to the Indian Region Genera of Heterotermitinae .....	470
Genus 15. <i>Heterotermes</i> Froggatt	
1. Characters of Genus <i>Heterotermes</i> .....	472
2. Distribution and Composition of <i>Heterotermes</i> .....	474
3. Keys to Indian Region Species of <i>Heterotermes</i> .....	475
70. <i>Heterotermes balwanti</i> Mathur and Chhotani .....	476
71. <i>Heterotermes ceylonicus</i> (Holmgren) .....	479
72. <i>Heterotermes gertrudae</i> Roonwal .....	483
73. <i>Heterotermes indicola</i> (Wasmann) .....	487
74. <i>Heterotermes malabaricus</i> Snyder .....	491
Genus 16. <i>Reticulitermes</i> Holmgren	
1. Characters of Genus <i>Reticulitermes</i> .....	495
2. Distribution and Composition of <i>Reticulitermes</i> .....	497
3. Keys to Indian Region Species of <i>Reticulitermes</i> .....	497
75. <i>Reticulitermes assamensis</i> Gardner .....	498
76. <i>Reticulitermes chinensis</i> Snyder .....	501
77. <i>Reticulitermes saraswati</i> Roonwal and Chhotani .....	506
78. <i>Reticulitermes tirapi</i> Chhotani and Das .....	508
Subfamily (iv) TERMITOGETONINAE Holmgren	
1. Characters of Subfamily Termitogetoninae .....	511
2. Distribution and Composition of Termitogetoninae .....	512
Genus 17. <i>Termitogeton</i> Desneux	
1. Characters of Genus <i>Termitogeton</i> .....	513
2. Distribution and Composition of <i>Termitogeton</i> .....	514
79. <i>Termitogeton umbilicatus</i> (Hagen) .....	514

## Subfamily (v) RHINOTERMITINAE Froggatt

1. Characters of Subfamily Rhinotermitinae .....	518
2. Distribution and Composition of Rhinotermitinae.....	520
3. Keys to Indian Region genera of Rhinotermitinae .....	520
Genus 18. <i>Prorhinotermes</i> Silvestri	
1. Characters of Genus <i>Prorhinotermes</i> .....	523
2. Distribution and Composition of <i>Prorhinotermes</i> .....	523
80. <i>Prorhinotermes flavus</i> (Bugnion and Popoff) .....	524
Genus 19. <i>Parrhinotermes</i> Holmgren	
1. Characters of Genus <i>Parrhinotermes</i> .....	528
2. Distribution and Composition of <i>Parrhinotermes</i> .....	529
81. <i>Parrhinotermes khasii</i> Roonwal and Sen-Sarma .....	529
Genus 20. <i>Schedorhinotermes</i> Silvestri	
1. Characters of Genus <i>Schedorhinotermes</i> .....	533
2. Distribution and Composition of <i>Schedorhinotermes</i> .....	534
3. Keys to Indian Region Species of <i>Schedorhinotermes</i> .....	535
82. <i>Schedorhinotermes eleanorae</i> Roonwal and Bose .....	537
83. <i>Schedorhinotermes longirostris</i> (Brauer) .....	540
84. <i>Schedorhinotermes medioobscurus</i> Holmgren .....	544
85. <i>Schedorhinotermes sarawakensis</i> Holmgren.....	549
86. <i>Schedorhinotermes tiwarii</i> Roonwal and Thakur .....	554
87. <i>Schedorhinotermes translucens</i> (Haviland).....	559
Family V. STYLOTERMITIDAE Holmgren and Holmgren	
1. Characters of Family Stylotermitidae.....	565
2. Distribution and Composition of Stylotermitidae.....	567
3. Phylogeny of Stylotermitidae.....	567
Genus 21. <i>Stylotermes</i> Holmgren and Holmgren	
1. Characters of Genus <i>Stylotermes</i> .....	570
2. Distribution and Composition of <i>Stylotermes</i> .....	570
3. Keys to Indian Region Species of <i>Stylotermes</i> .....	570
88. <i>Stylotermes ahmadi</i> Akhtar .....	573
89. <i>Stylotermes beelsoni</i> Thakur .....	575
90. <i>Stylotermes bengalensis</i> Mathur and Chhotani.....	578
91. <i>Stylotermes chakratensis</i> Mathur and Thapa .....	582
92. <i>Stylotermes dunensis</i> Thakur .....	584
93. <i>Stylotermes faveolus</i> (Chatterjee and Thakur).....	588
94. <i>Stylotermes fletcheri</i> Holmgren and Holmgren.....	591
95. <i>Stylotermes parabengalensis</i> Maiti .....	596

Family VI. INDOTERMITIDAE Roonwal and Sen-Sarma	
1. Characters of family Indotermitidae . . . . .	599
2. Distribution and Composition of Indotermitidae . . . . .	600
3. Phylogeny of Indotermitidae . . . . .	601
Genus 22. <i>Indotermes</i> Roonwal and Sen-Sarma	
1. Characters of genus <i>Indotermes</i> . . . . .	602
2. Composition and Distribution of <i>Indotermes</i> . . . . .	602
3. Keys to Indian Region Species of <i>Indotermes</i> . . . . .	603
96. <i>Indotermes arshadi</i> Akhtar. . . . .	604
97. <i>Indotermes maymensis</i> Roonwal and Sen-Sarma . . . . .	606
98. <i>Indotermes rongrensis</i> (Roonwal and Chhotani) . . . . .	609
<b>BIBLIOGRAPHY</b> . . . . .	617
<b>SUBJECT INDEX</b> . . . . .	665

## INTRODUCTION

### DEFINITION OF ISOPTERA

Order ISOPTERA Brullé

(Greek : *iso*, equal; *ptera*, wings)

(Order Isoptères Brullé 1832, p. 66. For other synonyms, see Snyder, 1949, p. 9.)

The unique and universal occurrence of a form of wing microsculpturing in the Isoptera, as demonstrated in recent years (vide infra, Wing microsculpturing) makes this an essential character for the Isoptera. The order, as thus characterised, is redefined as follows (Roonwal, 1983b, c):-

*Diagnosis (Figs. 1, 3): ISOPTERA : Social and polymorphic insects living in large or small colonies composed of winged and apterous (neotenic) reproductive forms of both sexes (produced periodically) together with numerous apterous forms (mostly workers and fewer soldiers, the latter caste in a few species entirely wanting). Mouth parts of the biting-grinding type. Tarsi with 3-5, generally 4, segments. Cerci short to long. External genitalia wanting or rudimentary in both sexes except in Mastotermitidae females. With two pairs of long, membranous, similar and subequal wings; in repose resting flat on the body-dorsum; anal lobe wanting except in the Mastotermitidae. Anterior veins strongly sclerotised; regular cross-veins wanting but an irregular network or archedictyon often present. Wings shed at a basal suture. Both upper and lower wing surfaces covered densely (up to over 12,500 or more per square millimetre, and sometimes with over half a million on each surface) with a variety of microscopic, cuticular structures of at least eight types; of these only the papillae are universally present, the others being present or absent; not more than three or four types present simultaneously in a species. Metamorphosis slight or absent.*

A more detailed description is given below, the order being characterised by the following combination of characters :

Small to medium-sized, soft-bodied insects with a subcylindrical, weakly sclerotized body. Social and polymorphic. Live in small to very large colonies; some species making large earthen mounds or nests of wood-carton. With winged or apterous reproductive forms, together with numerous apterous nonreproductive soldiers and workers. Head hypognathous or prognathous, with mandibulate mouth-parts of the typically biting-grinding type; mandibles in soldiers usually large, prominent and variously shaped, but reduced and nonfunctional in the nasutiform genera. Antennae moniliform, with 10-32 segments. Frons usually with a conspicuous frontal pore or fontanelle for the discharge of the frontal gland secretions especially in soldiers. Compound eyes, and sometimes a pair of ocelli, present in reproductive forms, but usually absent in soldiers and workers. Thorax with subequal segments; pronotum either flat or saddle-shaped. Legs small, adapted for walking. Tarsi with 3-5 segments, most often 4. With two pairs of similar, thin, semitransparent wings superimposed flat over the back when at rest and capable of being shed (soon after the swarming flight) by means of fractures at the basal or humeral suture. Venation simple, longitudinal. Anterior veins strongly chitinised; regular cross-veins wanting but an irregular network of slightly chitinised veins (archedictyon) often

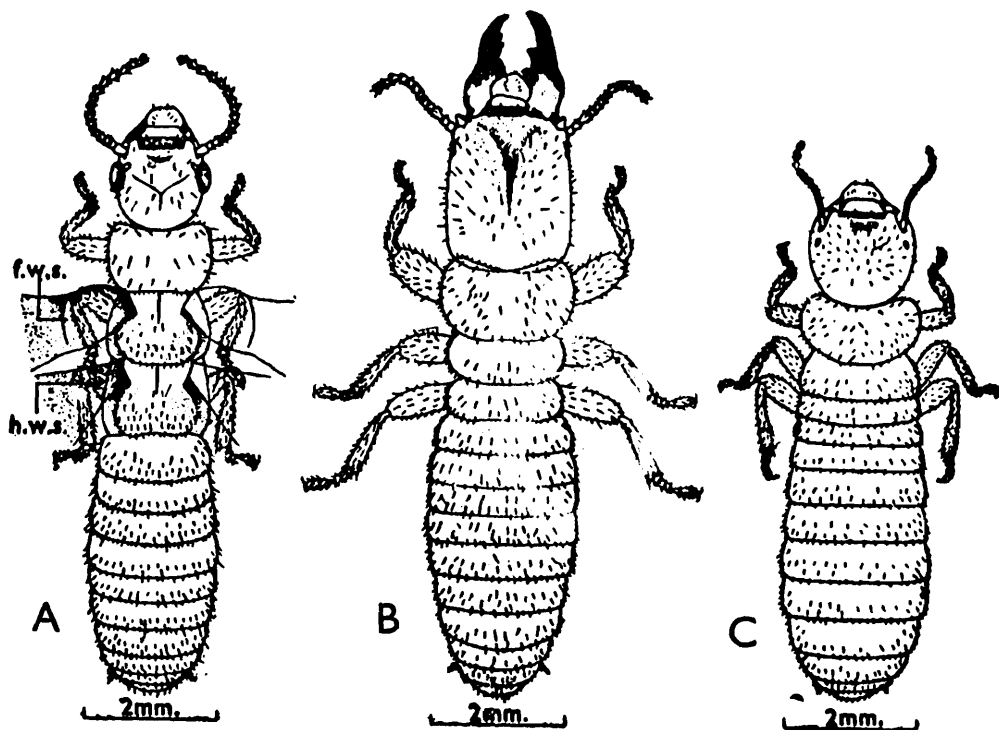

Fig. 1. *Bifiditermes beesoni* (Kalotermitidae), various castes. (A) Imago (only wing scales shown). (B) Soldier. (C) Pseudoworker. (Ex Roonwal and Sen-Sarma 1960.).  
f.w.s., forewing scales; h.w.s., hindwing scales.

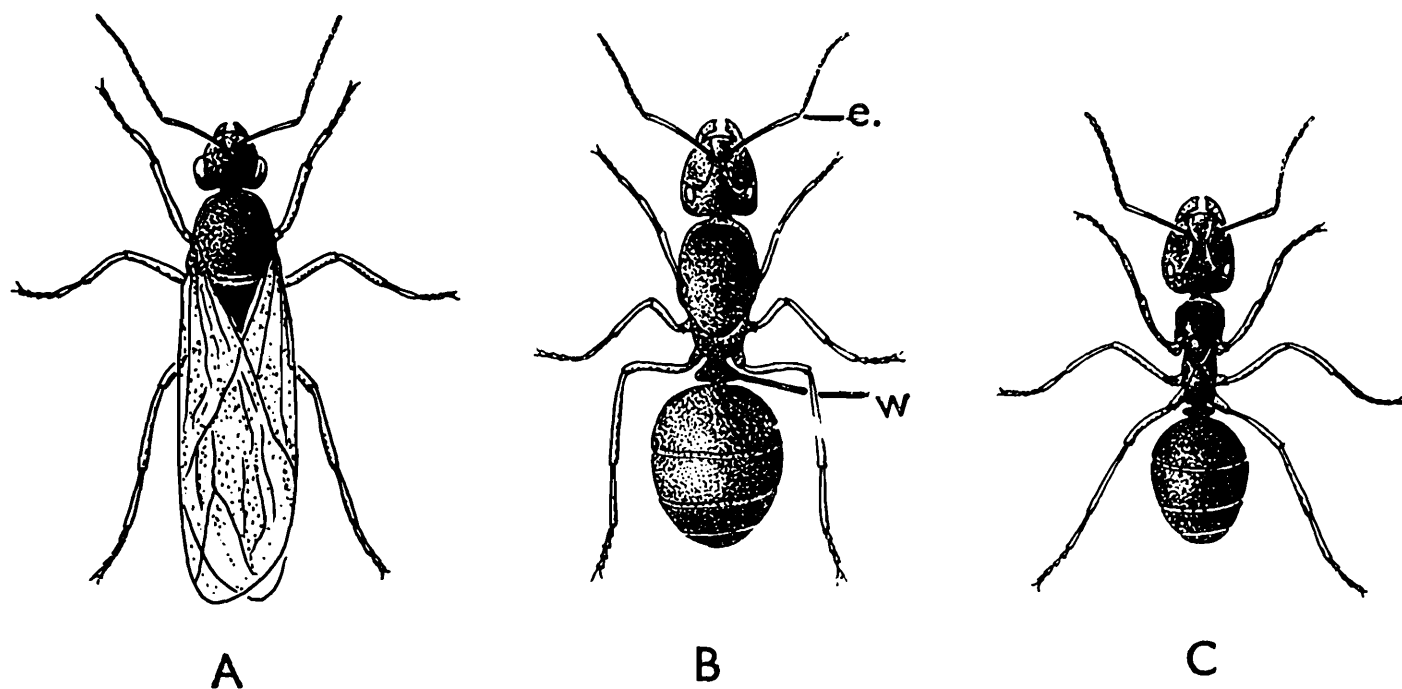

Fig. 2. Ants, in dorsal view (ex Gösswald). (A) Male (winged). (B) Female. (C) Worker.  
e., elbow of antenna ; W., waist.

present in primitive forms; venation and archedictyon specialised, by reduction, in higher forms; anal lobe rarely present. Wing membrane covered on both sides by numerous chitinised microscopic structures of two broad types, e.g., distally directed minute papillae at the anterior and posterior margins present universally in all Isoptera; and a second type of variously-shaped, usually nondirected structures such as minute pimpules, larger rods, microsetae, micrasters and tubercles, of which not more than two or three types are present simultaneously in a species. Abdomen with 10 similar segments and a reduced 11th one (present in embryos but fused with the 10th in postembryonic stages); the 7th sternum relatively enlarged in females, forming a subgenital plate. External genitalia generally weak and rudimentary. Cerci short to long, 1 to 8-jointed, present in all castes. Unjointed anal styles frequently present on the 9th sternum, usually in males only in the reproductive caste, and in both sexes in soldiers and workers. Metamorphosis slight or absent. Eggs usually laid singly, occasionally in oothecae and ribbons. Symbiotic intestinal Protozoa and bacteria often present and assist in the digestion of cellulosic food material.

Termites, sometimes miscalled white-ants, are small, soft-bodied insects which range in colour from dull white to yellow and light or darkbrown, occasionally almost black. They range in length from a few to c 20 mm

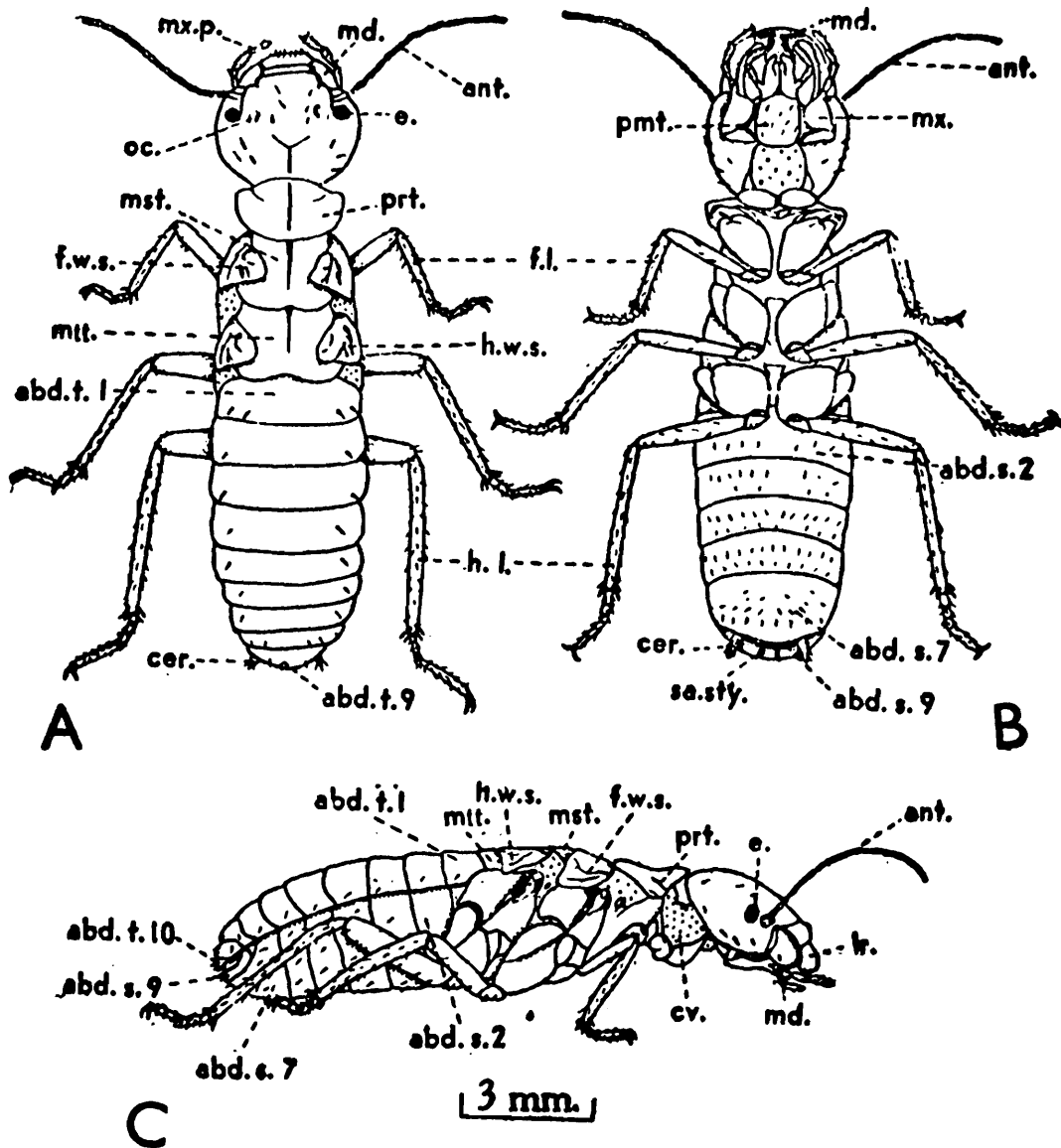

Fig. 3. *Anacanthotermes macrocephalus*, imago. (A) Dorsal view (only wing scales shown).

(B) Ventral view. (C) Lateral view. (Ex Gupta 1962b.)

abd. s.1- abd. s.9. abdominal sterna 1-9; abd. t.1- abd. t. 10, abdominal terga 1-10.; ant., antennae; cer., cercus; e., eye; f.l., foreleg; f.w.s., forewing scale; h.l. hind-leg; h.w.s., hindwing scale; lr., labrum; md., mandibles; mst., mesonotum; mtt., metanotum; mx., maxilla; mx.p., maxillary palp; oc., ocellus; pmt., postmentum; prt., pronotum; sa. sty., subanal style.

without wings, and c 40 mm with wings. They can be separated from true ants (Fig. 2), which belong to the order Hymenoptera, by readily observable combination of characters (Table 1).

Table 1. Differences between termites and ants. (Also see Figs. 1 and 2).

Termites (Fig. 1)	Ants (Fig. 2)
1. Belong to order Isoptera.	1. Belong to order Hymenoptera.
2. Colour dull white to light or dark brown; rarely black.	2. Colour often black; also brown to reddish brown.
3. Antennae not elbowed	3. Antennae elbowed.
4. Fore-and hindwings subequal.	4. Forewings much larger than hindwings.
5. Abdomen basally wide, not constricted to form a waist; first abdominal segment not fused with metathorax.	5. Abdomen basally constricted to form a thin waist; first abdominal segment fused with metathorax.

*Common names* : The following are the common names of termites in the principal languages of India: Hindi: *Deemāk*. Punjabi: *Saink, seonk, deemak*. Gujarati: *Deemak, udei* (mound, *rafda*). Rajasthani: *Udei*. Bengali: *Ooi, ooli*. Assamese: *Bagaparua*. Ooriya: *Ooi*. Marathi: *Walwai*. Konkani: *Valati*. Tamil: *Karayan*. Telugu: *Cheda purugu*. Malayalam: *Chithal*. Kannada: *Geddalū hula*. Sanskrit: *Ghuna, Kashtaharika* (wood-feeder), *upajihawaka* (mound-builder); mound, *vapa, valmika*.

### BRIEF HISTORY OF TERMITE STUDY

The first historical mention of termites (*ghuna*) as destroyers of wood appears to be in the ancient Sanskrit text, the *Rig Veda*, ca. 1350 B.C. (Snyder 1956). More certain is their mention in the *Mahabharata* (ca. 700 B.C. to early A.D.) where mention is made of termites having built a mound (*valmika*) all over the meditating sage, Sukanya, on the banks of the river Narmada, leaving only his eyes uncovered. In Sanskrit writings of the first century A.D., termites are referred to as *Kasthaharika* (eaters of wood) (Rao 1957). Curiously, termites find no mention in the ancient Egyptian hieroglyphics.

In modern times, the first scientific contributions on termites are by König (1779) in Peninsular India and Smeathman (1781) in Africa. Among other things, both of them described large termite mounds. In Europe, Latreille (1795) and Lespes (1856) made notable observations on termite castes and polymorphism, and Hagen gave (1852-1860) the first taxonomic

monograph of world termites. The first notable accounts on biology, especially life-history, are by F. Müller (1873) and by Grassi and Sandias (1893, 1894).

An active period followed, and in the last decade of the 19th and the early part of the 20th century contributions of great importance on taxonomy and biology were made by several workers all over the world, notably by Wasmann (1893-1934), Froggatt (1895-1897, Australia), Sjöstedt (1900-1926), Silvestri (1901-1947), Desneux (1902-1918), Holmgren (1906-1917), Escherich (1911, Sri Lanka), Bugnion (1912-1915, Sri Lanka), Fuller (1915-1924, South Africa), and Hill (1915-1942, Australia).

Entomologists in India in the early part of the 20th century were, however, indifferent to termites and were content with repeating generalised control measures. Thus, Lefroy (1909) in his otherwise comprehensive work, *Indian Insect Life*, lists just 20 species grouped in three genera, *Termopsis*, *Termes* (with 4 subgenera: *Leucotermes*, *Arrhinotermes*, *Coptotermes* and *Eutermes*) and *Hodotermes*. In his account of South Indian insects, Fletcher (1914) lists only 3 species: *Coptotermes heimi*, *Odontotermes* sp. and *Microtermes* sp. And even 25 years later, Ayyar (1940) in his book, *South Indian Insects*, gives casual attention to termites; he provides no names and merely figures a species from Sri Lanka (*Odontotermes horni*).

The second and third quarters of the 20th century were a very active period and many contributions, including comprehensive books, were published by numerous workers, especially by Snyder (1920-1949, culminating in his world *Catalogue* 1949), Light (1921-1946), Emerson (1924-1975), Kemner (1925-1934), Grassé (1937-1949), especially his comprehensive account in *Traite d. Zool.*, IX, 1949, and Roonwal and his co-workers (1953-1988), especially the Oriental Region). The books of Hegh (1922), Kofoid (1934, 1946, control), Krishna and Weesner (1969-1970) and Weidner (1970a) should also be mentioned. Since the 1960s, active work is being done in China.

Today almost 2000 species of termites are known from the world, and a little over 300 from the Indian Region.

## CHARACTERS USEFUL IN TAXONOMY

## USEFUL CHARACTERS FROM EXTERNAL MORPHOLOGY

1. *General*

The characters of external anatomy provide the most important and practically useful criteria for the classification and taxonomic differentiation of termites at all levels. Internal anatomy has also been used to some extent, but is of limited use and, in addition, necessitates the mutilation of specimens for purposes of dissection. Due to the occurrence of polymorphism (Fig. 1) in all species, the three principal types of polymorphs (castes), viz., the reproductives, the soldiers and the workers (the last two being neuters), have to be described separately (for details, *vide infra*). Sexual dimorphism, which is only a special case of polymorphism, is evident in the reproductives and to a lesser extent in the neuters. The two sexes can generally be separated by the enlargement of the seventh abdominal sternum in the female as compared to the male, and a few other less marked differences (*vide infra* for more details). For the separation of species and subspecies, however, they are relatively unimportant, and separate descriptions of the sexes are unnecessary.

Preliminary work on chaetotaxy suggests that it is of limited help in taxonomy, but its use should not be rejected out of hand, and more work is necessary to determine its utility (for more details, *vide infra*.)

The comparative sizes of the external body-parts and their ratios provide very important differentiating characters, especially at the specific and subspecific levels, and here the method of measurement and the limits of the parts measured are important (for details *vide infra*).

The termite body is, as in most insects, composed of three principal parts, viz., the head, thorax and abdomen (Fig. 3). The head is joined to the thorax through a small cervix or neck whose morphological origin is unclear. The abdomen abuts on the thorax directly with a broad base (and not via a slender waist or pedicel as in ants). Embryologically, the insectan head is composed of seven (six according to some authorities) primary segments, the thorax of three and the abdomen of twelve.

The descriptions refer first to the reproductive imago, with the neuters compared briefly where necessary.

## 2. The Head

(Figs. 4 and 5)

The imago head (or head-capsule as it is sometimes called) is roundish or slightly oval in outline and is dorso-ventrally flattened. The sides carry a pair of large, roundish compound eyes, and sometimes a pair of small ocelli close to the eyes. The paired antennae arise just in front of the eyes. The head is prognathous, i.e., the mouth-parts are directed forward. A Y-shaped

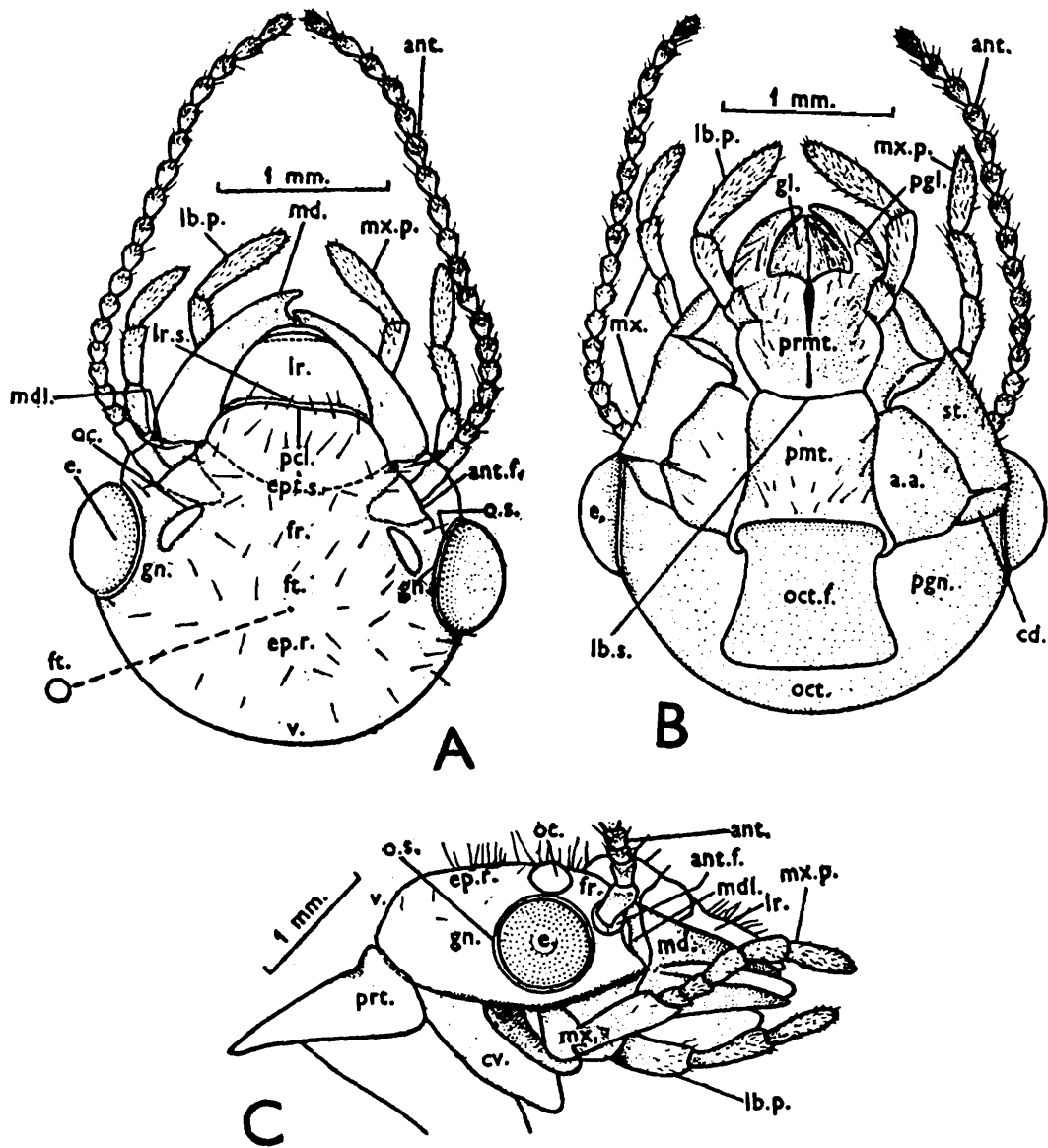

Fig. 4. *Odonotermes obesus*, imago. (A) Head capsule, in dorsal view. (B) Same, in ventral view. (C) Same, in side view (with pronotum). (Ex Kushwaha, 1960b).

a.a., articulating area; ant., antenna; ant.f., antennal foveola; cd., cardo; cr., cervix; e., eye; ep.r., epicranial region; ept.s., epistomal suture; fr., frons; ft. fontanelle; gl., glossa; gn., gena; lb. p., labial palp; lr., labrum; lr.s., labral suture; md., mandible; mdi., mandibularia (or trochantin) of mandible; mx., maxilla; mx.p., maxillary palp; oc., ocellus; oct., occiput; oct.f., occipital foramen; o.s., ocular suture; pcl., postclypeus; pgl., paraglossa; pgn., postgena; pmt., postmentum; prmt., prementum; prt., pronotum; st., stipes; v., vertex.

*epicranial suture* is generally present on the head-dorsum, the stem of the Y forming a median line running backward, and the two arms diverging forward. The anterior part of the head-dorsum forms the *frons* (or front) and the posterior part the *epicranium* (or parietal region). The anterior region of the head forms the *labrum* of variable form which is followed by the clypeus, the latter being transversely divisible into a more posterior *postclypeus* (firmly attached to the frons) via an *epistomal suture* and an *anteclypeus*.

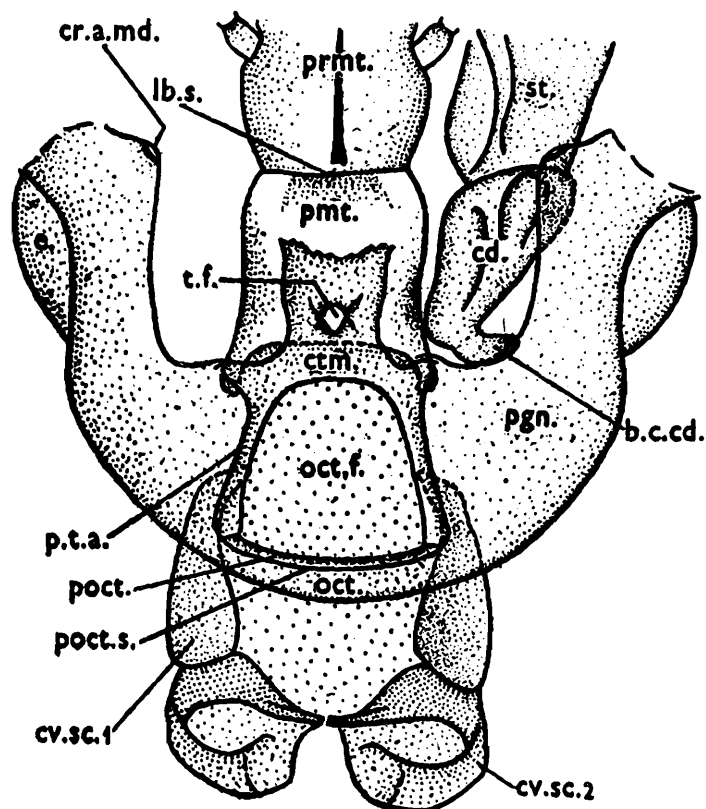

Fig. 5. *Odontotermes obesus*, imago. Ventral wall of cranium and cervix. (Ex Kushwaha 1960b).

b.c.cd., basal condyle of cardo; cd., cardo; cr.a.md., cranial articulation of mandible; ctm., corpotentorium; cv.sc. 1, first cervical sclerite; cv.sc. 2, second cervical sclerite; e. eye; lb.s., labial suture; oct., occiput; oct.f., occipital foramen; pgn., postgena; pmt., postmentum; poct., postocciput; poct.s., postoccipital suture; prmt., prementum; st., stipes; t.f., tentorial foramen.

The lateral parts of the head constitute the *genae* (or cheeks). When seen from the ventral side, a large opening, the *occipital foramen* (foramen magnum of authors), is seen at its posterior end.

The various sclerites and appendages of the head may now be discussed.

*Labrum and clypeus* (Figs. 7): The labrum is rather broad and often tongue-shaped (other shapes also occur); it has a membranous tip and overlies the mandibles. It is rather uniform in imagoes and workers of different species (cf. soldiers). The anteclypeus is membranous and flexible. The postclypeus is well-sclerotised and is in some groups (Rhinotermitidae and Termitidae) divided by a longitudinal groove into two halves.

*Antennae* (Fig. 7): The two moniliform antennae are lodged in a rounded depression or *antennal fossa*, and are about 9 to 33-segmented, the primitive forms having the larger number. The first or basal segment (*scape*) is long; the second (*pedicel*) is also relatively long but is shorter than the first. The remaining segments form the *flagellum*. The third segment varies greatly between species, and the segments which immediately precede and follow it provide important specific differences. The reason of this variability probably lies in the fact that during postembryonic development the addition of new segments occurs by growth and subdivision of the third segment and those which are its direct derivatives.

*Compound eyes* (Fig. 4): The paired compound eyes are well developed in imagoes. They are usually large and rounded in outline (elongated dorso-ventrally in the Termopsidae, e.g., *Zootermopsis*), and often more or less swollen. They carry numerous ommatidial facets, and are generally darker than the rest of the head-capsule.

*Ocelli* (Fig. 4) The two lateral ocelli are minute, carry a single lens, and lie just above the eyes either close to, or well apart from, the latter (this distance often provides a good taxonomic character). The shape is usually elongate-oval, but varies considerably. Ocelli are weak or absent in the Hodotermitidae. The Isoptera do not possess a median ocellus (vide infra).

*Mid-dorsal spot* (Fig. 6): A small, pale area in the middle of the head-dorsum of some termites (*Speculitermes* workers) has been misinterpreted as a median ocellus ("Stirnocellus") by Wasmann (1902a, p. 161) and as a fontanelle by Holmgren (1913b, p. 268). The position has been clarified by Roonwal and Sen-Sarma (1960, p. 15) who have termed this structure as the *mid-dorsal spot*. It is a small, pale, translucent or semi-opaque, flat or slightly raised area on the head-dorsum and varies in outline from round to subtriangular (Fig. 6). It provides diagnostic characters.

*Epicranial or Y-suture* (Fig. 1A): Its development varies a great deal. It may be well marked, poorly developed or partly developed or absent. (The

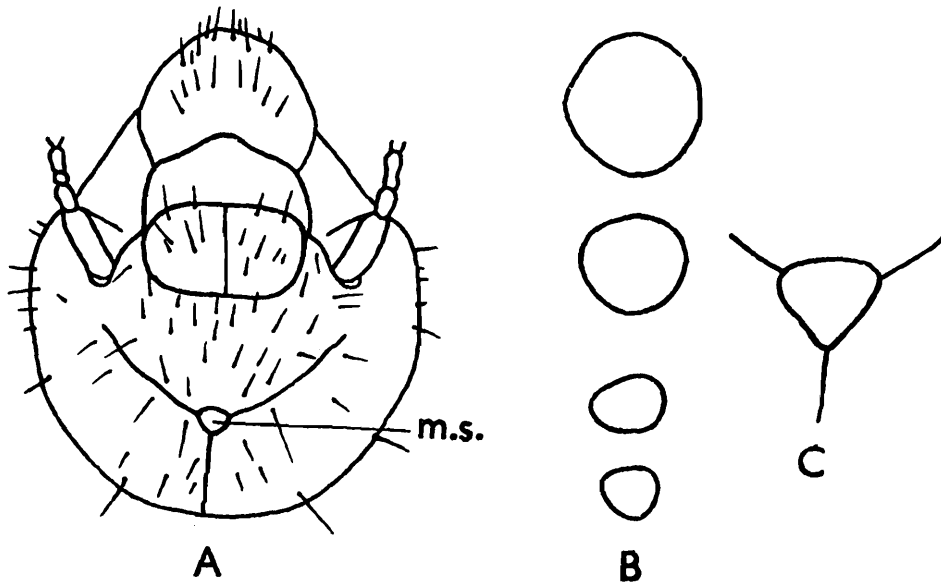

Fig. 6. Mid-dorsal spot of head. (A) On head of *Speculitermes sinhalensis* R. & S. (B) Variations in mid-dorsal spots of same. (C) Mid-dorsal spot of *S. triangularis* R. & S.  
m.s., mid-dorsal spot.

two lateral branches have been termed as transverse sutures by some authors.)

**Fontanelle** (Fig. 4A) : In families whose head carries the frontal gland (Rhinotermitidae and Termitidae), the gland opens to the outside in the middle of head-dorsum by means of a minute median aperture, the *fontanelle*. It lies just behind or between the compound eyes. It may be rounded or slit-like, and may be conspicuous or ill-marked. It may lie on a raised area, the *fontanelle plate* (as in several Termitidae), or in a small depression; or a shelf-like projection may cover the aperture from behind. Its shape may show sexual dimorphism, as in some Nasutitermitinae (vide Roonwal, 1975d for a summary); it may be U-, V-, or Y-shaped in males and Y-shaped or slit-like in females. (The fontanelle has sometimes been confused with a small, pale area, also lying in the middle of head-dorsum, which is not an aperture at all; it is the mid-dorsal spot of Roonwal and Sen-Sarma, 1960, vide supra.)

**Frontal gland armature** : In the Rhinotermitidae the frontal gland on the head is more or less well developed in the various genera. Quennedey and

Deligne (1975) have used this gland, its pore (the fontanelle) and the associated cephalic structures (frons, clypeus and labrum) as a systematic character in soldiers. In all the genera of the subfamily Rhinotermitinae except *Prorhinotermes* there is present, at the distal end of the labrum, a 'daubing brush' of hairs, etc. for spreading the gland secretion on the enemy. They, therefore, separate genus *Prorhinotermes*, which lacks the daubing brush, into a separate subfamily, the Prorhinotermitinae.

*The mouth-parts* consist of a pair of mandibles, a pair of maxillae and a median, fused labium.

*Mandibles* (Figs. 7B, 8 and 9): The two mandibles, which are of the biting-chewing type, are massive, squarish, hard, chestnut-coloured structures lying on either side of the mouth. They are articulated with the head at two points: a posterior or primary mandibular articulation, the *ginglymus*, which is socket-like and articulates with a convex projection of the clypeus, and an anterior or secondary articulation, the *condyle*, which is a rounded projection fitting into a socket at the lower end of the gena. The outer margin is smooth and convex, while the inner margin is substraight or slightly concave and is armed with a number of *teeth* in the distal half, the proximal half forming the *molar* plate. The imago and worker mandibles carry an apical tooth and a varying number (1-4) of marginal teeth, the right mandible generally having fewer marginals than the left. The number and character of teeth provide some classificatory characters, but of limited value (Holmgren 1909-1912, Ahmad 1950, Weesner 1969), because the teeth themselves are not always well marked. This limitation is further enhanced by the fact that authors interpret the homologies of the marginal teeth in widely different ways. It is sometimes generalised that the primitive families have more teeth than the advanced ones. But there are so many exceptions, as will be seen from what follows, that the generalisation is of little phylogenetic value.

The Mastotermitidae (in several other respects, the most primitive family) is rather more advanced in mandibles. Both the left and right mandibles have only two marginal teeth, the second marginal of the right being weak. There is no subsidiary tooth in front of the first marginal of the right (cf. Termopsidae and Hodotermitidae and others).

The Termopsidae has three marginals on the left mandible and two on the right, the latter carrying a small additional or "subsidiary tooth" just

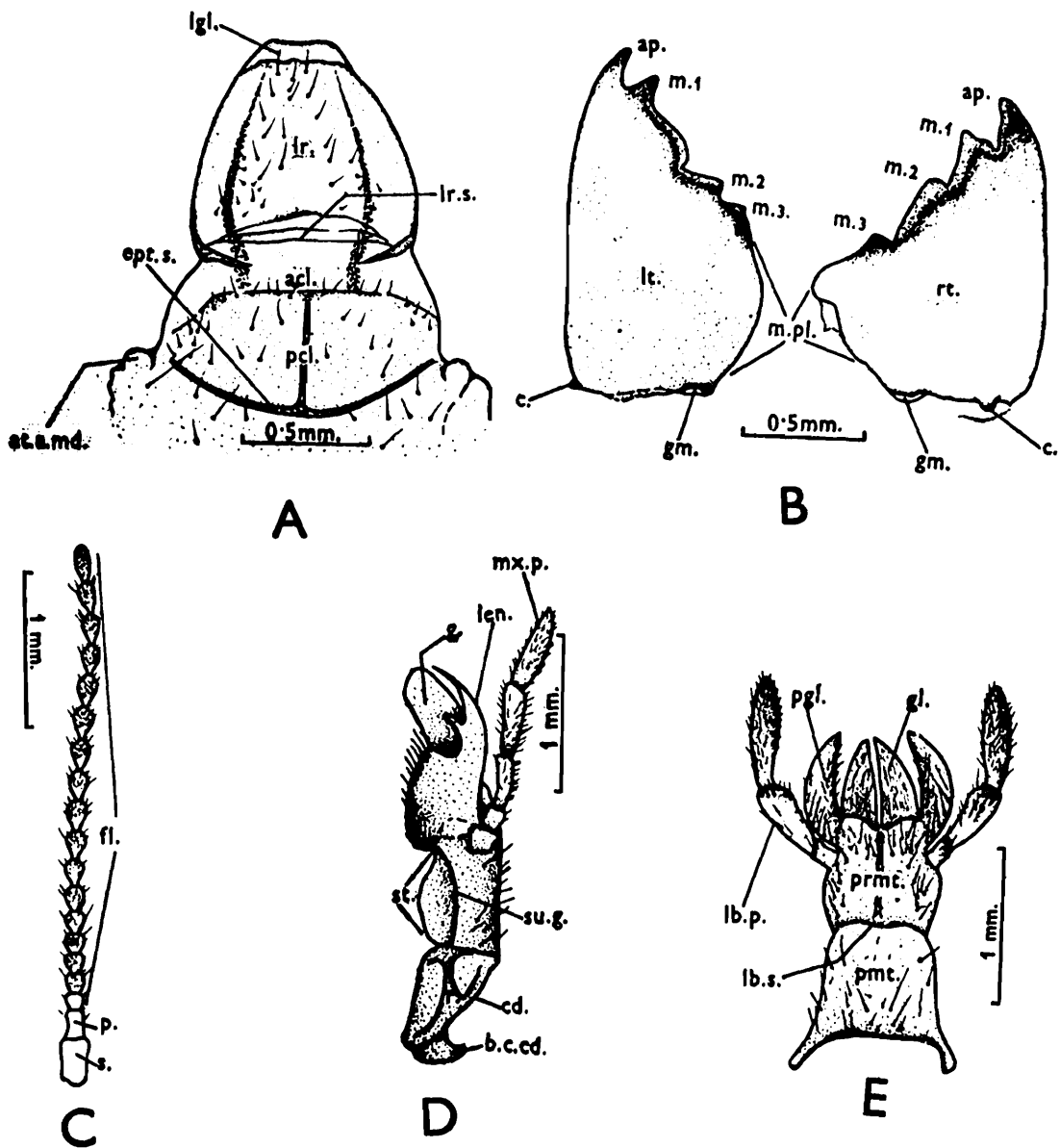

Fig. 7. *Odontotermes obesus*, imago. Mouth-parts etc., (Ex Kushwaha 1960b.) (A) Labrum and clypeus. (B) Mandibles. (C) Antenna. (D) Maxilla. (E) Labium.  
 acl., anteclypens; ant., antenna; ap., apical tooth; at.a.md., anterior articulation of mandible; b.c.cd., basal condyle of cardo; c., condyle of mandible; cd., cardo; ept.s., epistomal suture; f., flagellum; g., galea; gl., glossa; gm., ginglymus; lb. p., labial palp; lb.s., labial suture; lcn., lacinia; lgl., lingula (hyaline tip of labrum); lr., labrum; lr. s., labral suture; lt., left.; m<sub>1</sub>-m<sub>3</sub>, first to third marginal teeth of mandibles respectively; m.pl., molar plate; mx.p., maxillary palp; p., pedicel; pcl., postclypeus; pmt., postmentum; prmt., prementum; rt., right; s., scape; st., stipes; su.g., sutural groove of stipes.

in front of the first marginal as in some Hodotermitidae and others. The Hodotermitidae seems to be the most primitive family in respect of the mandibular teeth, and has an apical and 2 to 4 marginals on left mandible

(2 *Anacanthotermes*, 3 *Hodotermes*, *Stolotermes*, 4 *Porotermes*); and an apical and two marginals on the right. Sometimes, a small “subsidiary tooth” is present on the anterior margin of the first marginal of the right mandible.

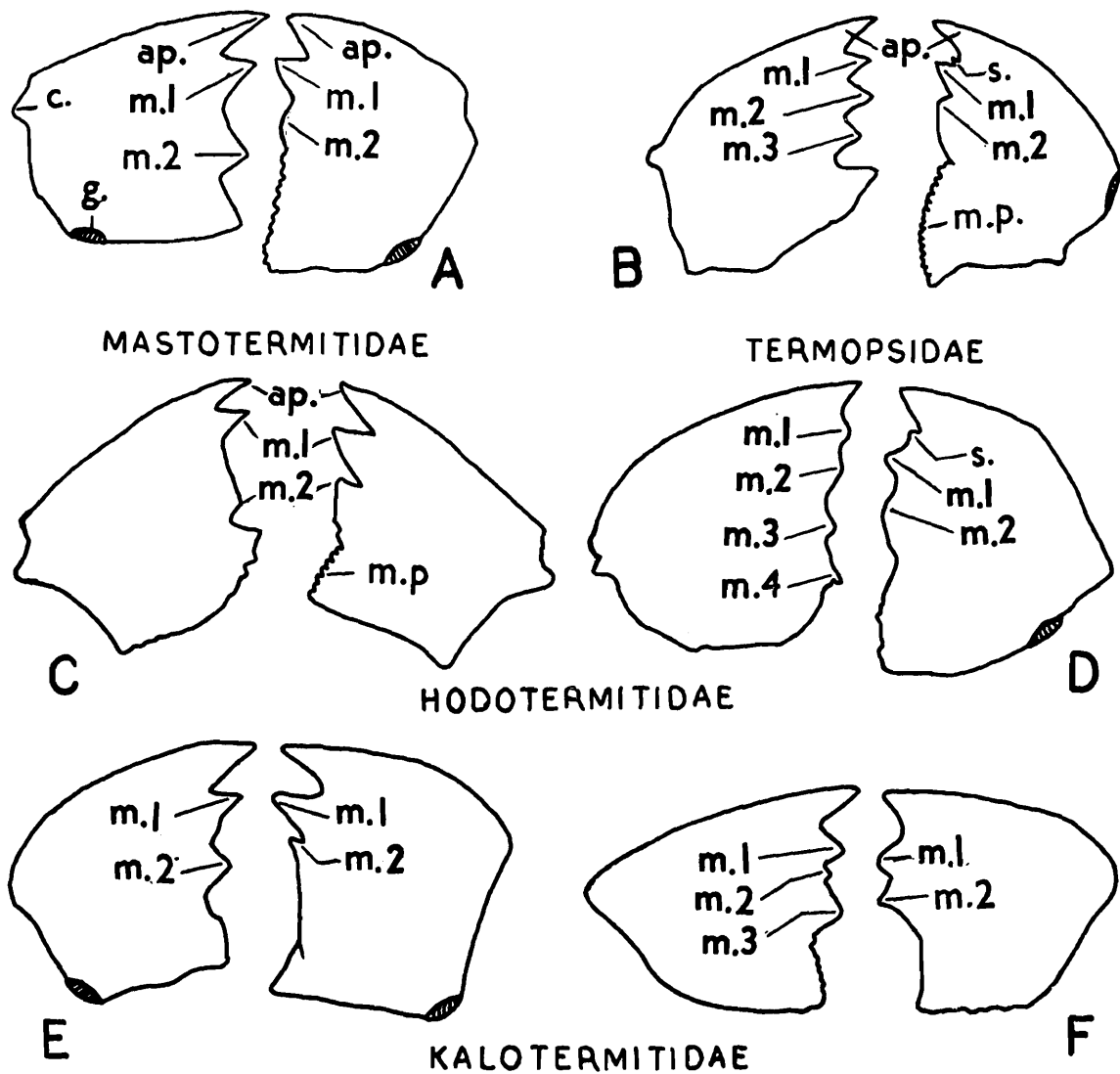

Fig. 8. Imago mandibles of some termites. (A) *Mastotermes darwiniensis* (Mastotermitidae). (B) *Archotermopsis wroughtoni* (Termopsidae). (C) *Anacanthotermes macrocephalus*. (D) *Porotermes* sp. (ex Weesner) (Both Hodotermitidae.) (E) *Postelectrotermes militaris*. (F) *P. nayari*, pseudoworker. (Both Kalotermitidae.)

ap., apical tooth; c., condyle; g., ginglymus; m1-m4; first to fourth marginal teeth; m.p., molar plate; s., subsidiary tooth.

The Kalotermitidae has two marginal teeth on the left mandible (sometimes three, as in the pseudoworker of *Postelectrotermes nayari* R. & V., vide Roonwal and Verma, 1971, the second marginal here being greatly reduced, see Fig. 8 F). The right mandible has two marginals, and there is

no subsidiary tooth in front of the first marginal. (Krishna, 1961, p. 315, without bringing forth any developmental or other evidence, regards the first marginal as the fused first and second, and the second marginal as the third.)

The Stylotermitidae has three marginal teeth on the left mandible and also two on the right, with a small subsidiary tooth in front of the first in the latter. The Rhinotermitidae resembles the Stylotermitidae in having three marginals on the left mandible and two on the right, with a subsidiary tooth

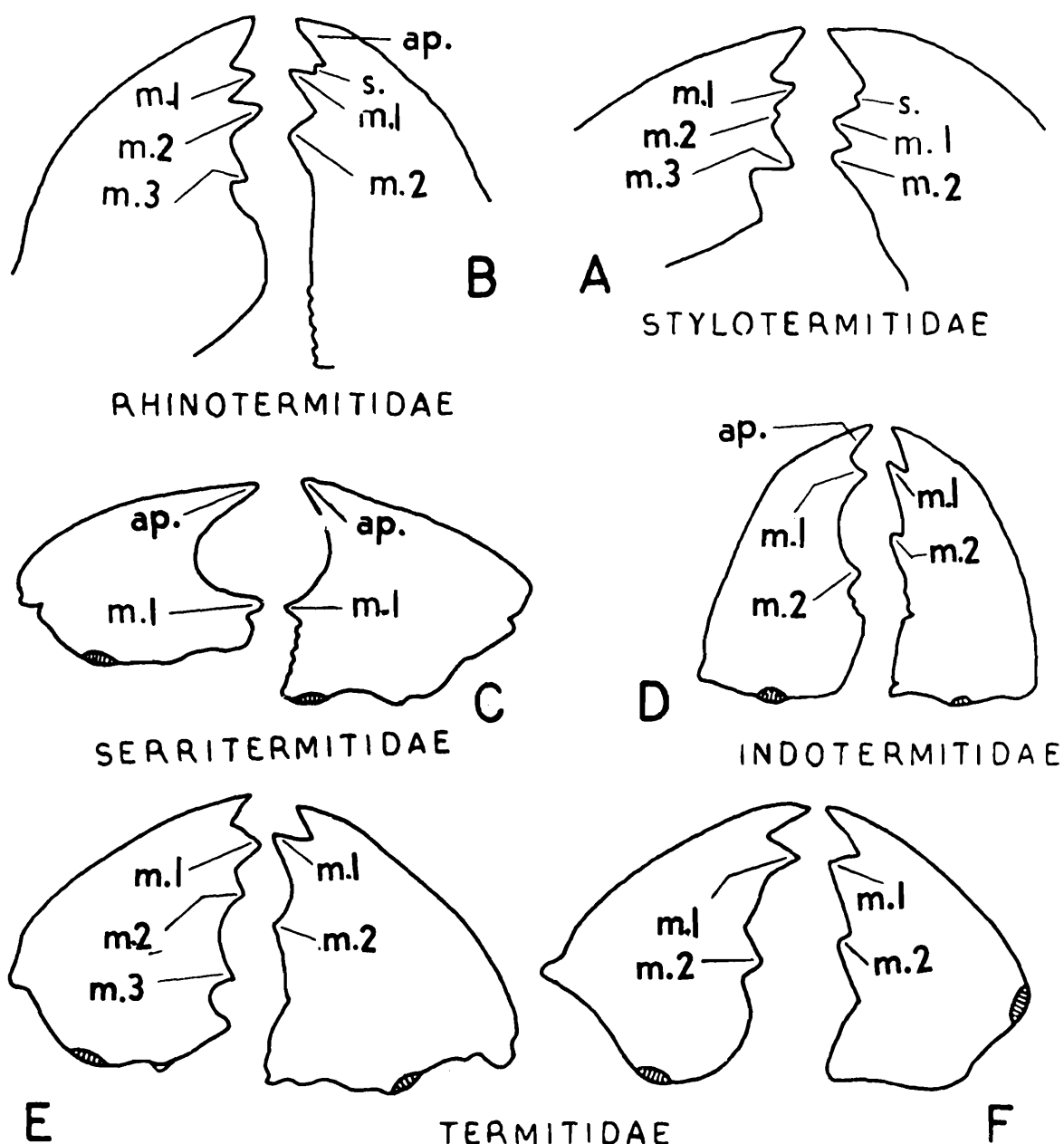

Fig. 9. More imago mandibles of termites. (A) *Stylotermes fletcheri* (Stylotermitidae). (B) *Coptotermes formosanus* (Rhinotermitidae). (C) *Serritermes serrifer* (Serritermitidae). (D) *Indotermes thailandis*, worker. (Indotermitidae). (E) *Protohamitermes* sp. (ex Ahmad). Termitidae. (F) *Odontotermes microdentatus* (Termitidae). ap., apical tooth; m1-m3, first to third marginal teeth; s., subsidiary tooth.

on the latter. The Serritermitidae has a large and conspicuous apical tooth and a single marginal tooth which is widely separated from the apical by a long, incurved margin. The Indotermitidae has two marginals on both mandibles, the second marginal being small (*Indotermes thailandis*, worker, vide Ahmad, 1963, who however, places this genus in the family Termitidae, subfamily Amitermitinae).

The large family Termitidae tends to be uniform. There are generally two marginal teeth on the left mandible (three in *Protohamitermes*, Ahmad 1950), and two on the right, the two being usually separated by a long gap. (Some authors interpret, as in the Kalotermitidae, the first marginal tooth as the fused first and second marginals, and the second marginal as the third; but there seems to be no embryological or other basis for this interpretation.) Besides these teeth there is sometimes present, on the left mandible, a "molar tooth" which may be visible from above, and in some such cases the true second marginal is absent. These complications should be borne in mind in homologising the teeth of the two sides.

**Maxillae** (Fig. 7 D) : The maxillae are paired and lie behind the mandibles. Each maxilla consists of a basal piece, the *cardo*, followed by a larger plate, the *stipes*. The latter structure is elongated and carries distally two sclerites (a mesial one, the *lacinia*, which is toothed, and an outer one, the *galea*, which is usually two-segmented). Laterally, the stipes carries the longish, 5-jointed *maxillary palp* whose basal joint is often ill-marked.

**Labium** (Fig. 7 E) : The labium (or second maxillae) is the most posterior of the mouth-parts and forms a large, plate-like structure on the ventrum of the head. Embryologically it is paired in origin like the other cephalic appendages, but the two elements fuse together into a single, median sclerite (the evidence of its paired origin can still be seen in its distal parts, the ligula and the labial palps). It is composed of two parts, viz., an anterior or distal *prementum*; and a larger, posterior or proximal *postmentum* (miscalled gula or gulamentum by some authors), the two being separated by the transverse *labial suture*. The postmentum varies in shape, etc. from group to group and provides important differentiating characters. The prementum, on the other hand, is more uniform; its distal part forms the paired *ligula* each member of which divides further into an inner *glossa* and an outer *paraglossa*. The lateral part is projected into a *palpiger* each of which carries a 3-jointed *labial palp*.

### *The head in neuters and immatures :*

The immatures and workers generally resemble the imagoes, but a few noteworthy differences occur. The compound eyes and ocelli are often lacking, and, if present, the eyes are small and ill-developed. The antennae have fewer segments in nymphs. The epicranial suture, often ill developed in imagoes, is well marked in immatures and workers. The mid-dorsal spot (vide supra) is better marked in the workers of some groups (*Speculitermes*) than in imagoes and provides important taxonomic characters.

The head of soldiers (Fig. 10) differs markedly from imagoes and workers and provides good taxonomic characters. It is often massive and varies greatly in shape from group to group, being squarish, subrectangular, oval, pear-shaped, truncated and nasute (round with a long, frontal nose-like projection). The labrum shows great differences which are of taxonomic value. The number of antennal segments varies from about 11 to 29, and the third segment varies greatly (in *Marginitermes hubbardi*, according to Weesner, 1969, p. 33, it is as long as the next 6 or 7 segments put together).

The soldier mandibles show an enormous and rather inexplicable degree of variability in size and shape. They may be long, massive and multidentate (Kalotermitidae, Hodotermitidae); long and sword-like; long, twisted and asymmetrical (*Capritermes* series); in most Nasutitermitinae they are minute and vestigial.

### 3. *The Cervix or Neck* (Fig. 5)

The cervix constitutes a small moveable area between the head and the prothorax. In its membrane lie, on either side, a pair of large *lateral cervical sclerites*, the two sclerites of a pair being aligned at right angles to each other. Dorsal and ventral cervical sclerites are generally not present in termites, but their vestiges may sometimes occur (some Hodotermitidae). The distal of the two plates articulates with the occipital condyle of the head, while the proximal one hinges on the prothoracic episternum. The cervical sclerites are generally believed to be formed by a fusion of the posterior margin of the last or labial segment of the head and the anterior part of the prothorax, though some authorities regard it as a distinct segment, the microthorax.

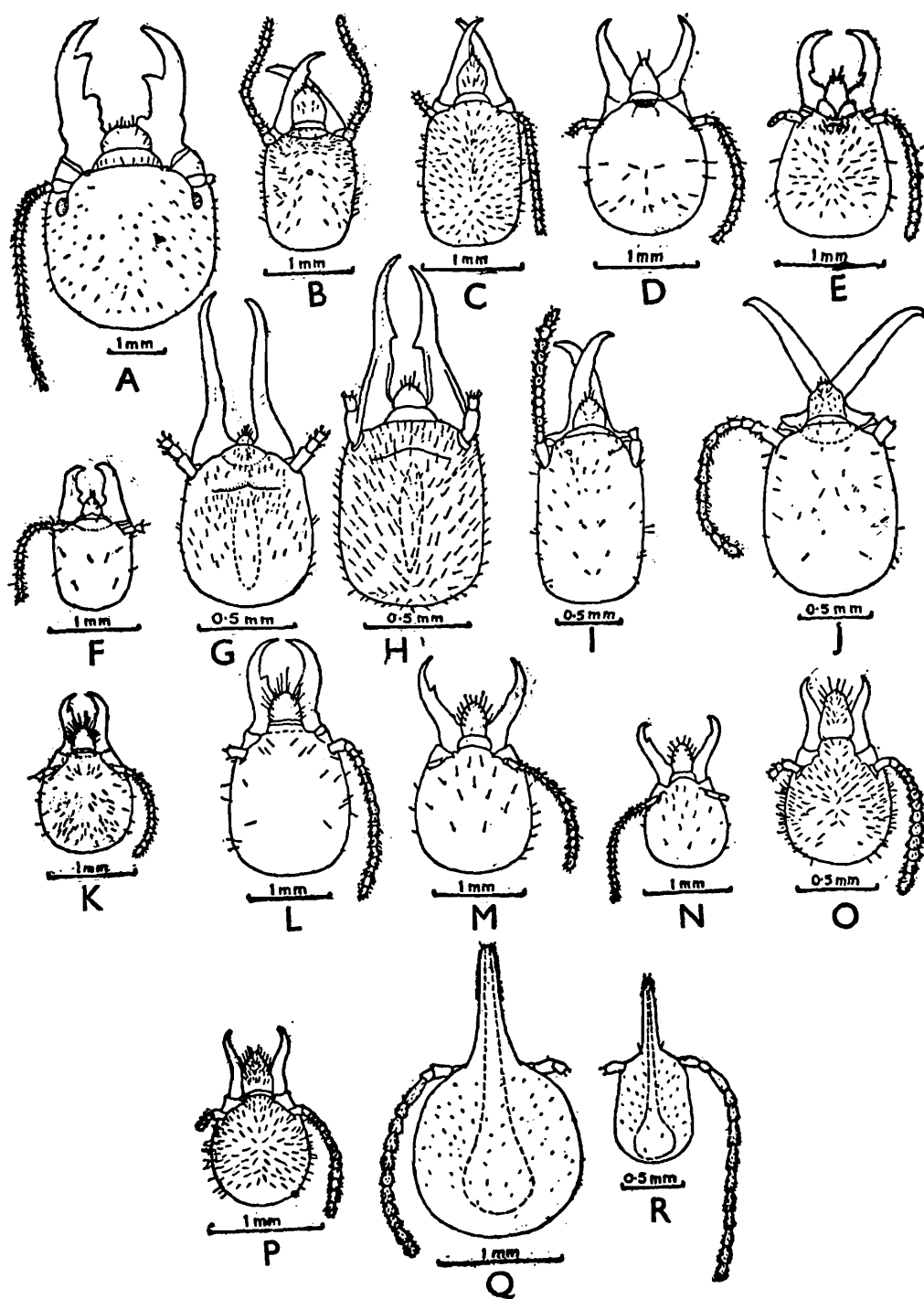

Fig. 10. Heads of soldiers of some Indian termites. (Ex Roonwal 1977c, adapted.) (A) *Anacanthotermes macrocephalus*. (B) *Psammotermes rajasthanicus*, soldier minor. (C) *Heterotermes indicola*. (D) *Coptotermes heimi*. (E) *Amitermes belli*. (F) *Synhamitermes quadriceps*. (G) *Eremotermes neoparadoxalis*. (H) *E. paradoxalis*. (I) *Microcerotermes raja*. (J) *M. laxmi*. (K) *Odontotermes guptai*. (L) *O. kushwahi*. (M) *O. obesus*, large soldier. (N) Same, small soldier. (O) *Microtermes obesi*. (syn. *M. anandi*). (P) *M. mycophagus*. (Q) *Trinervitermes biformis* (syn. *T. heimi*), soldier major. (R) Same, soldier minor.

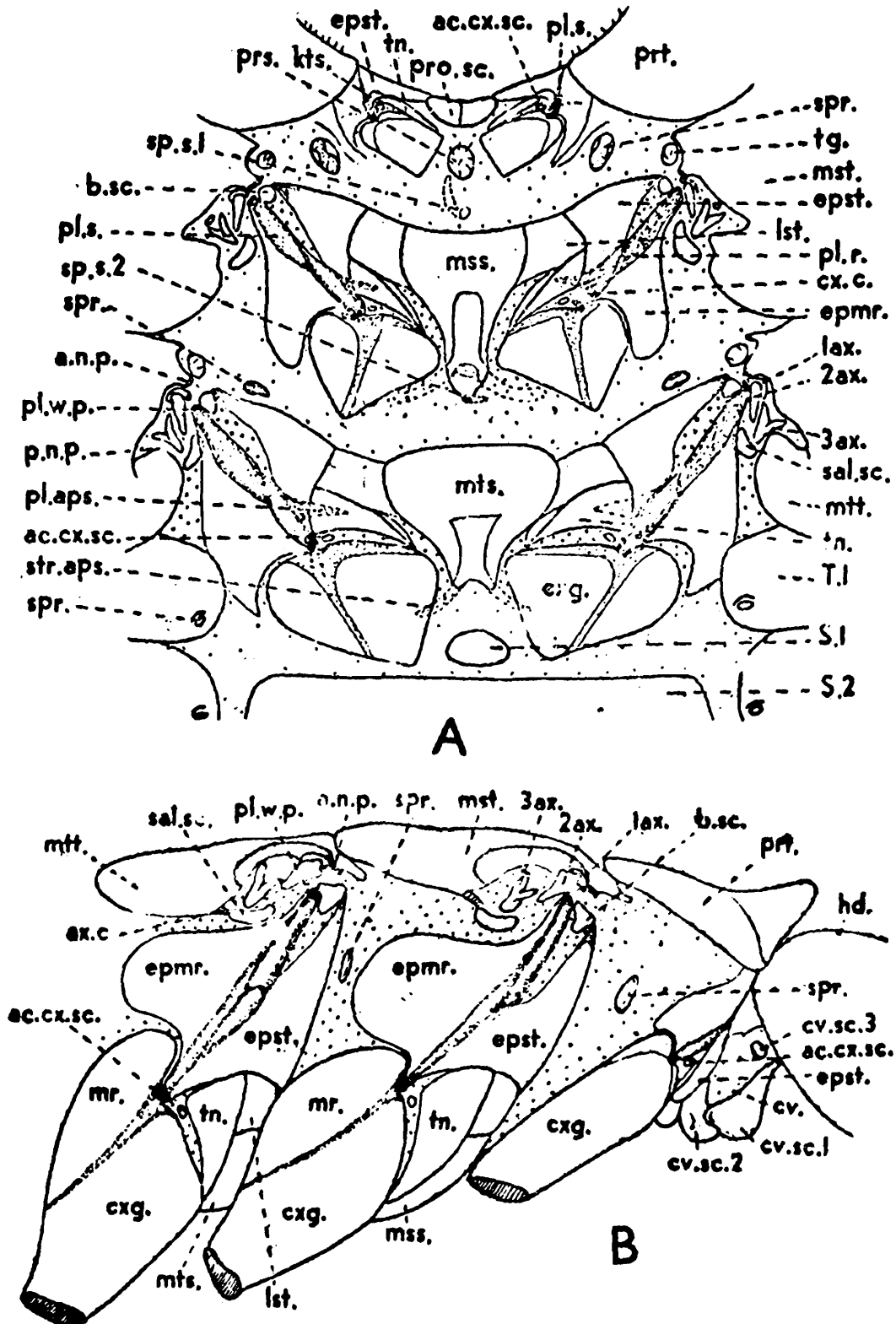

Fig. 11. *Anacanthotermes macrocephalus*, imago. (A) Thorax, in ventral view. (B) Thorax and cervix. (Ex Gupta 1962b).

ac.cx.sc., accessory coxal sclerite; a.n.p., anterior natal process of meso- and metanotum; b.s.c, basal sclerite of wing joint; cv. cervix; cv.sc. 1-3, first to third crevical sclerites; epmr., epimeron; epst., episternum; hd., head; kts., kata-episternum; lst., laterosternite; mr., meron; mss., mesosternum; mst., mesonotum; mts., metasternum; mtt., metanotum; pl.aps., pleural apophysis; pl.r., pleural ridge; pl.s., pleural suture; pl.w.p., pleural wing process; p.n.p., posterior natal wing process; pro.sc., prosclerite; prt., pronotum; prs., prosternum; s1-s3, first to third sterna; sal.sc., subalar sclerite; spr., spiracle; sp.sl, sp.s.2, first and second spinasternum; str. aps., sternal apophysis; tg., tegula; tn., trochantin of leg; T1, first tergum; 1-3 ax., first to third axillary sclerite of wing joint.

#### 4. The Thorax and Wings (Figs. 11-25)

##### (i) The main sclerites :

The thorax is composed of three distinct segments, viz., the prothorax, mesothorax and metathorax, from front to back (Figs. 1 A and 3 A). Each segment bears a pair of well developed legs, and the meso- and metathorax also bear a pair of wings each; these two wings-bearing segments together are sometimes called the pterothorax.

The structure of the thorax is quite complex (Fig. 11), and as most of the numerous sclerites which go into its making are of little taxonomic importance, only a brief description is provided below. For more detailed descriptions see the works of Fuller (1924), Grassé (1949), Kushwaha (1960 a, b), Gupta (1962 a, b), Weesner (1969), Weidner (1970 a), and others.

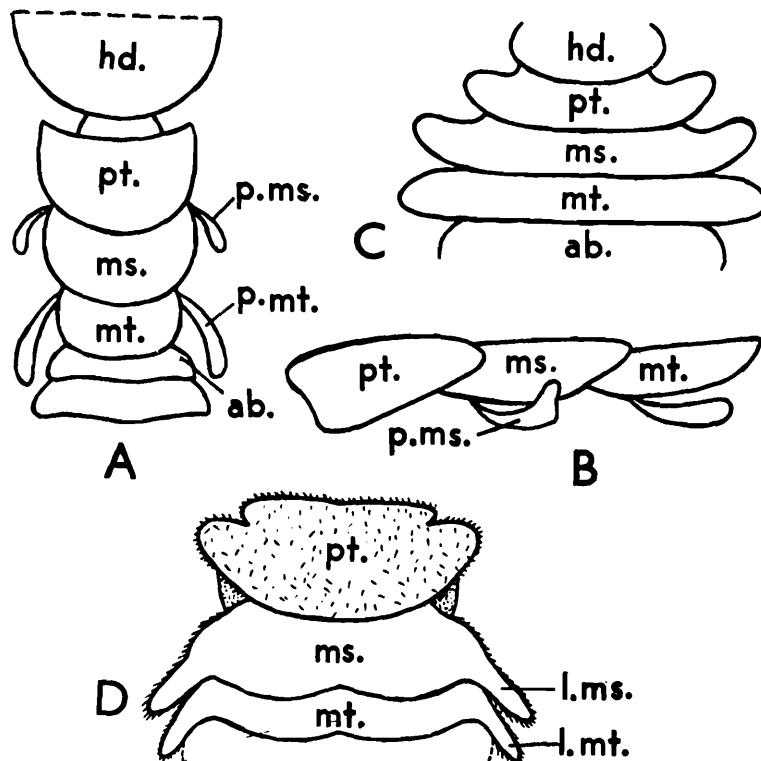

Fig. 12. Thoracic process. (A) *Styloterme fletcheri*, worker. (B) *Archotermopsis wroughtoni*, soldiers. In both note the pleural processes or flaps of meso- and metathorax. (C) *Glyptoterme dilatatus*, nymphs; lateral expansion of all thoracic terga. (D) Soldier-imago intercaste of *Nasutiterme matangensis*; lateral expansions of meso- and metanota. abd., abdomen; hd., head; l.ms., lateral expansion of mesonotum; l.mt., same of metanotum; ms., mesonotum; mt., metanotum; p.ms., pleural expansion of mesonotum; p.mt., same of metanotum.

Each segment exhibits the usual division into three principal parts, the dorsal sclerite or tergum (notum), the ventral sclerite or sternum, and the lateral membranous area, the pleuron (Figs. 11 and 12). The pronotum is well developed and varies greatly in shape, etc. so as to provide good taxonomic characters. It may be flat, saddle-shaped, shield-like, trapezoidal, etc., and may be laterally lobed, as in the nymphs of *Glyptotermes dilatatus* (Fig. 12 C) (Bugnion, 1915). It may be wider than the head or much narrower. The meso- and metanota are subequal in size and similar-looking and are less developed than the pronotum. They may be laterally expanded (Fig. 12), as in nymphs of *Glyptotermes dilatatus* (Bugnion, l.c.), soldiers (both normal and intercastes) in several species, e.g., *Zootermopsis angusticollis*, *Acanthotermes acanthothorax*, *Pterotermes occidentis*, *Termes baculi*, *Tumulitermes* sp., *Nasutitermes matangensis*, and others (vide Roonwal and Rathore 1975b for discussion).

The sterna, which lie on the ventral side, are ill-chitinised and membranous and are sometimes difficult to separate from the pleura. The prosternum is greatly reduced, and is sometimes (*Archotermopsis*) divided into two small plates separated by a membranous area. The mesosternum is well developed; its posterior margin articulates with a rod-like sclerite, the *mesosternellum*. The metasternum is also large, and its posterior margin articulates with a *metasternellum*. (These two sclerites are also sometimes called *furca*.) The sides of each sternum are separately sclerotised to form *laterosternites*, which also articulate with the *episterna*.

The pleuron forms the lateral membranous portion between the tergum and the sternum on either side. In some species, as in the workers, larvae and nymphs of *Stylotermes fletcheri* (Holmgren and Holmgren, 1917, Roonwal 1975a) the meso- and metapleura are prolonged into lobular processes (Fig. 12 A); in nymphs they are present in addition to the wing-pads with which they are not to be confused. Somewhat similar pleural processes (the epimera) occur in the meso- and metapleura of soldiers and pseudoworkers of *Archotermopsis wroughtoni*.

Each of the thoracic segments carries a pair of true legs, while the meso- and metathorax each carries, in addition, a pair of wings.

(ii) *The legs* (Fig. 13 - 17):

The three pairs of legs, lodged ventrolaterally on the thorax, are nearly alike (Fig. 13); they are long, slender and fully functional for walking.

They provide several characters of considerable taxonomic importance. Each leg is composed of the following joints and parts; starting from the base, they are the coxa, trochanter, femur, tibia, tarsus, endclaws and sometimes a pad or empodium (arolium) between the claws. The *coxa* is

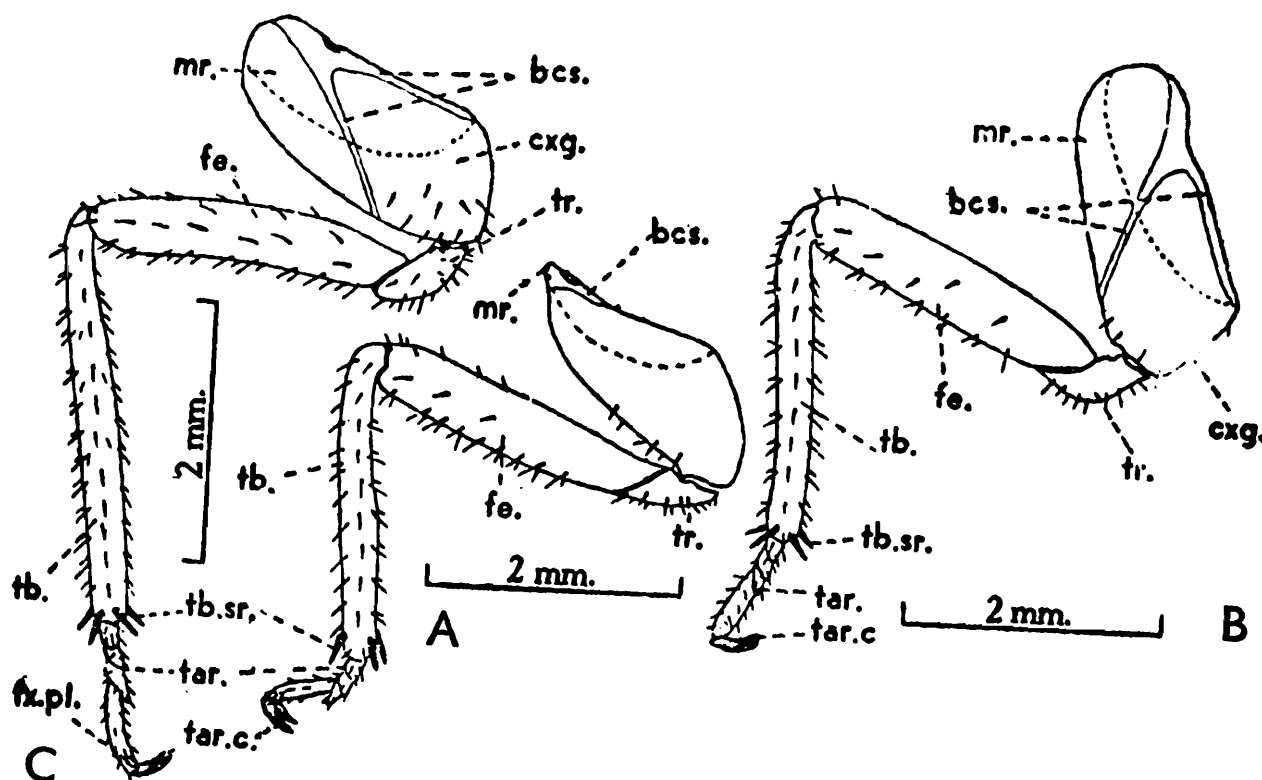

Fig. 13. *Anacanthotermes macrocephalus*. Legs of imago. (A) Foreleg. (B) Middle leg. (C) Hindleg. (Ex Gupta 1962b).

bcs., basicoxal suture of coxa; cxg., coxa genuiana (or coxa vera); fe., femur, fx.p., flexor plate (between claws and distitarsus); mr., meron; tar., tarsus; tar.c., tarsal claws; tb., tibia; tb. sr., tibial spur (apical); tr., trochanter.

quite large and broad and is attached to the pleuron. The coxae of the middle and hindlegs are divided into two parts by a deep suture an outer *meron* and an inner *coxa vera* (or *coxa genuina*). The *trochanter* is small; it articulates with the coxa proximally and with the femur distally.

The *femur* is a large, often swollen, joint. The *tibia* is long and slender; in addition to hair, it carries a number of lateral spines and distal apical spurs which are sometimes (*Mastotermes*, *Archotermopsis*) covered more or less thickly with microscopic, cuticular papillae or scales (Fig. 17) (Roonwal, 1983 b). Both spines and spurs are present in the primitive genera but the former tend to disappear in the advanced ones. The number of apical spurs, whose number varies from 2-4, is of taxonomic importance and is often

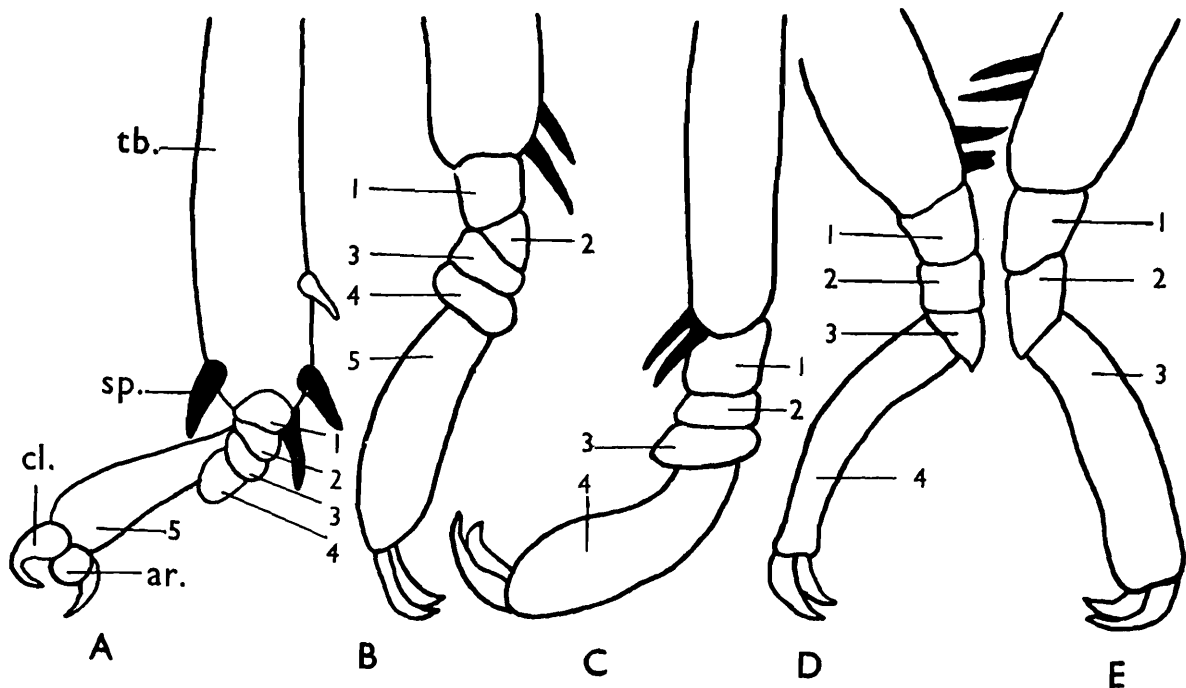

Fig. 14. Distal ends of the thoracic legs of termites, to show types of tarsal segmentation. (A) *Mastotermes darwiniensis*, foreleg of imago; 5 tarsal segments. (B) *Archotermopsis wroughtoni*, hindleg of soldier, inner view; 5 segments. (C) Ditto, foreleg of pseudo-workers, outer view; 4 segments. (D) *Speculitermes cyclops*, foreleg of imago; 4 segments. (E) *Indotermes maymensis*, foreleg of soldier; 3 segments. ar., arolium; cl., claws; sp., apical tibial spurs; tb., tibia; 1-5, 1st to 5th segments respectively of tarsus.

expressed as a tibial spur formula, e.g., 3:4:3, 3:3:3, 3:2:2, 2:2:2, etc. in the order fore, middle-and hind-tibia. The next joint is the *tarsus* which is composed of 3-5 segments and is of great taxonomic value (Figs. 14-16). The higher number of segments is generally a mark of primitiveness. The prevailing number of tarsal segments is 4, but the primitive family, Mastotermitidae has 5. In the two other primitive families, Termopsidae and Hodotermitidae, the tarsi are *imperfectly* 5-segmented (4 when seen from above and 5 from below). The Rhinotermitidae, Serritermitidae and Termitidae have 4 segments, while Stylotermitidae (*Stylotermes*) and Indotermitidae (*Indotermes*) have only 3 segments. (The statements of Ahmad, 1963, p. 395, Krishna, 1965, p. 3, and Weesner 1969, p. 41, that *Speculitermes* also has 3-segmented tarsi is erroneous; this genus always has 4 tarsal segments.) For a detailed discussion of tarsal segmentation, vide Roonwal (1975a).

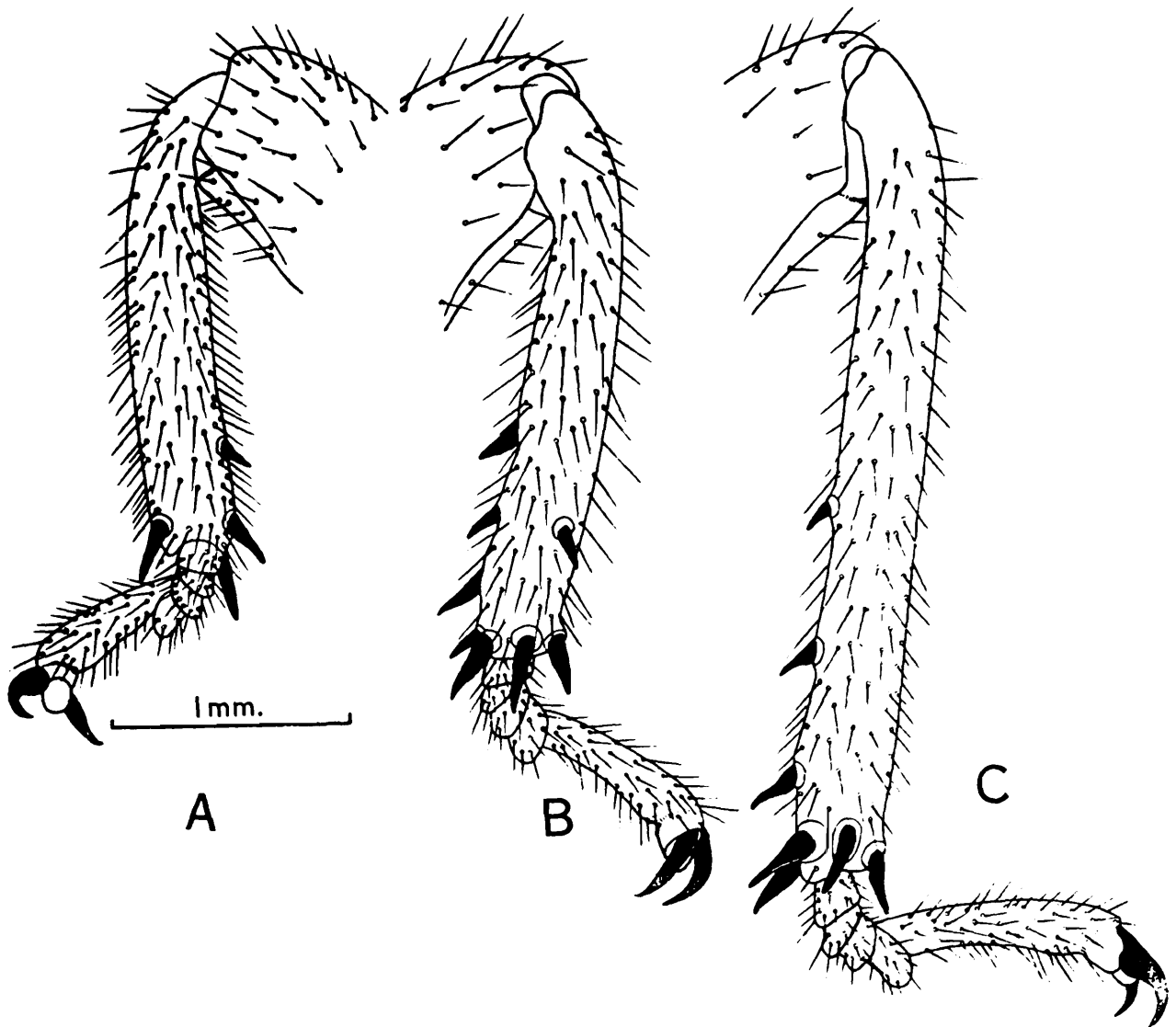

Fig. 15. *Mastotermes darwiniensis*, Lower halves of legs of imago; all have 5-jointed tarsi. (A) Foreleg. (B) Middleleg. (C) Hindleg.

The distal terminal end of a leg is armed with two strong, curved, pointed *claws*, between which there is sometimes present (*Mastotermitidae*, *Termopsidae*, some *Kalotermitidae*) a pad-like structure, the *empodium* (*arolium* of authors).

(iii) *The wing* (Fig. 18-25):

(a) *Wing venation* : The fore and hind pair of termite wings are subequal and nearly alike in size, form, venation, microsculpturing, etc. They are hinged to their respective segments by a complex series of sclerites which have no apparent taxonomic value and need not be described here. At rest, the wings fold over the body and extend considerably beyond the abdomen.

Near the base of each wing there is a convex line of weakness, the *basal* or *humeral suture*, along which the main or distal part of the wing is shed soon after the nuptial flight. The stump, called *scale*, which is left behind

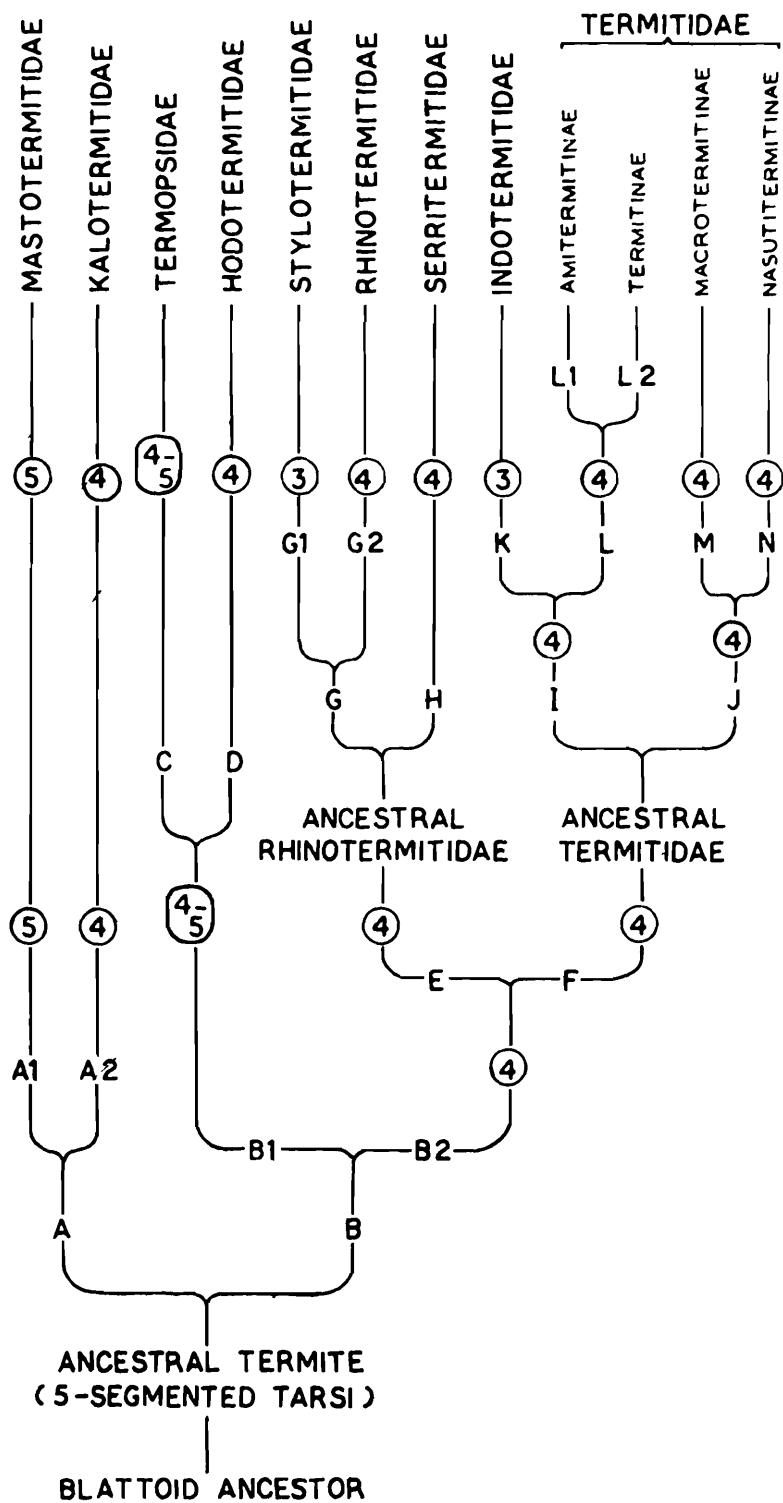

Fig. 16. Evolution of tarsal segmentation in the Isoptera. Numerals (3-5) inside circles indicate the number of tarsal segments. (Ex Roonwal 1975a.)

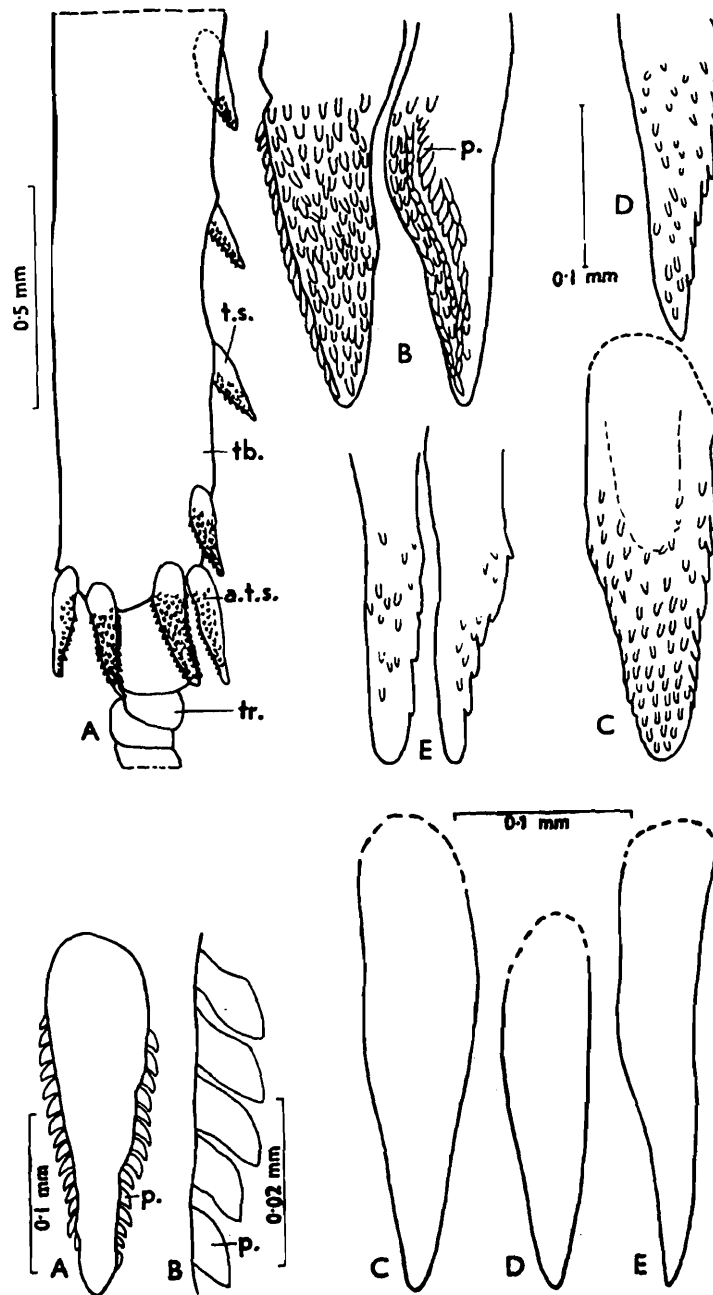

Fig. 17. Cuticular papillae on tibial spines and spurs in some termites (ex Roonwal 1983b).  
**Upper figs. (A-E): *Mastotermes darwiniensis*.** (A) Part of left hindleg of imago. (B) Apical tibial spurs of imago (left, inner view; right, side view). (C) Same, of nymph with wing pads. (D) Of worker. (E) Of soldier. **Lower figs. (A-E):** (A) Apical tibial spur of *Archotermopsis wroughtoni* (B) Same, enlarged lamellar papillae. (C-E). Naked, nonpapillate apical tibial spurs of *Anacanthotermes macrocephalus* (C, imago, D, worker; E, soldier).  
 a.t.s., apical tibial spur; p., papillae; tb., tibia; tr., tarsus; t.s., tibial spine.

remains attached to the body for life. The forewing scale is generally larger than the hindwing scale; the relative scale sizes also vary from group to group. The wing membrane, which is a thin, double-walled structure, is strengthened by numerous transverse veins, and is also densely covered over on both the upper and lower surfaces by a large number of minute, microsculpturing elements of various types (vide infra). Hairs are often present on wing margins in greater or lesser abundance; on the membrane they may be few or almost absent, or may occur in large numbers (thickly covering it, as in *Coptotermes*, *Syntermes*, etc.)

Wing venation (Figs. 18-20) is of considerable taxonomic value. The veins extend to the wing scale as well where their origin can often be clearly seen. Regular cross veins are wanting, but the membrane is sometimes covered with an irregular reticulum of minute veinlets, often collectively called the *archedictyon*. Venational nomenclature in termites is in a state of confusion and no two termitologists, beginning with Holmgren (1911c and 1912a), seem to agree, each one giving his own interpretation of homologies. The main reason for this divergence arises from the fact that developmental studies are lacking (a true vein is preceded by a tracheal tube), and comparative studies are also inadequate. Until this situation is rectified no uniformity on homologies may be expected. The following nomenclature must, therefore, be regarded as provisional. The primitive families have fuller venation than the others where reduction occurs in varying degrees. All the usual veins except the precosta seem to be present, viz., the costa (C), subcosta (Sc), radius (R), radial sector (Rs), media (M), cubitus (Cu) and anal (A). Some authors (e.g., Emerson 1965) consider the costa as being absent and regard the thickened anterior margin of wing as a 'costal margin' rather than the costa itself. A subcosta is generally present; it is often short and fused with the costa. The radius has up to three (sometimes four) branches. The radial sector, often 2-branched, may arise separately or may have a common origin with the media. The media may have a common origin with radius, radial sector or with the cubitus, and is often distally branched into two or more veins. The cubitus is always multi-branched, with sometimes up to 18 or more branches and covers a large area of the lower half of the wing. The anal is usually absent or very weak except in the hindwing of Mastotermitidae (*Mastotermes darwiniensis*) which has a large anal lobe with several anal branches (recalling the condition in cockroaches, Blattidae); the forewing is devoid of anal veins

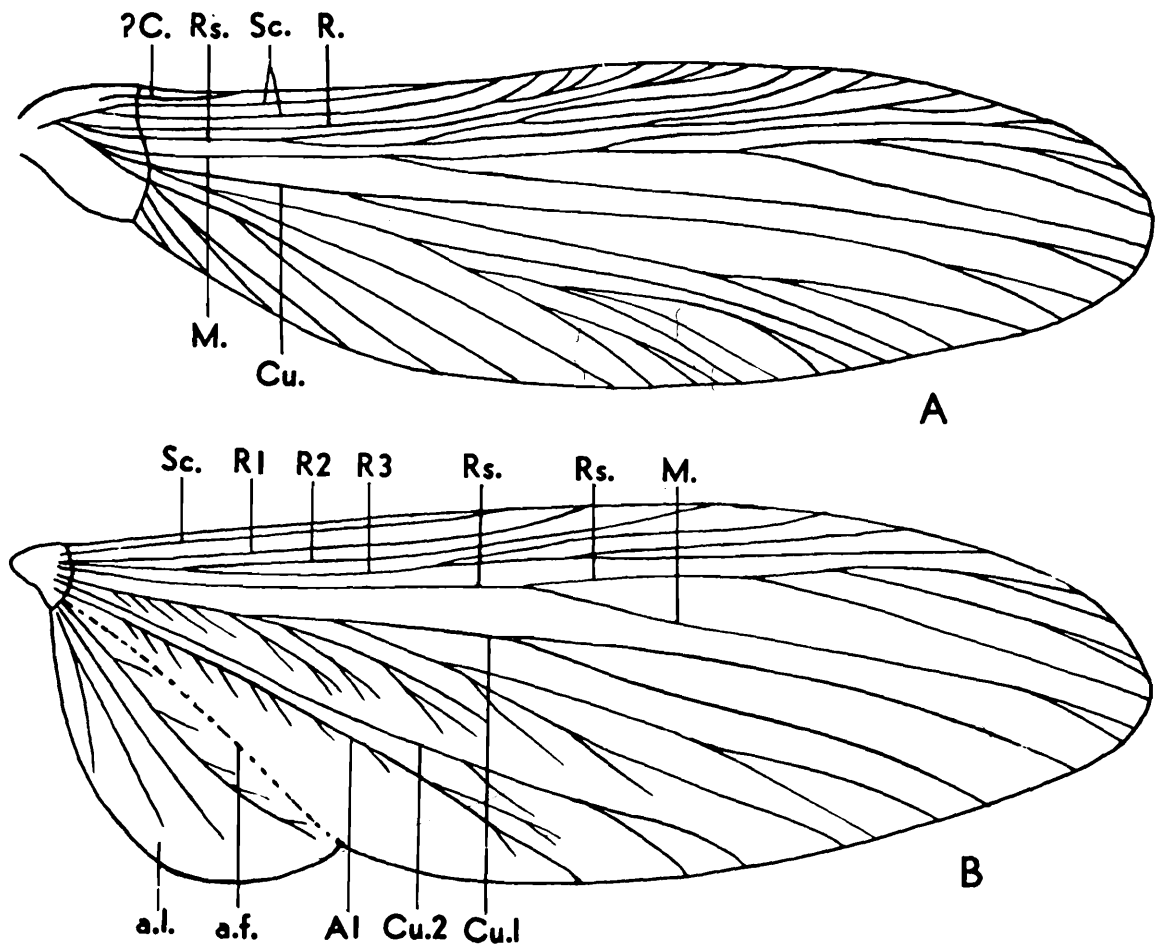

Fig. 18. *Mastotermes darwiniensis*, Wings. (A) Forewing, (B) Hindwing.

Al, first anal; a.f., anal fold.; a.l., anal lobe; c., costa; Cu, cubitus; Cu1, cu2, first and second cubital branches; M, media; R, radius; R1-R3, first to third radial branches; Sc, subcosta.

and there is no anal lobe. While this is the general condition, considerable individual variation may also occur within a species by suppression, extension and anastomosing of various veins, a situation which should be borne in mind in separating species on the basis of venation alone.

The most primitive condition is found in the Mastotermitidae (*Mastotermes darwiniensis*) and Termopsidae (*Archotermopsis*, etc.), while in the remaining groups considerable degree of reduction is evident, without, however, following any definite phylogenetic course. Thus, in *Coptotermes* which is not very advanced, venation is often marked by two thick, sclerotised veins (the costa- subcosta and radius) at the anterior margin of the wing, the rest of the wing membrane being marked by thin, hardly visible veins whose course can often be traced only with the aid of rows of hairs which they bear.

In *Mastotermes darwiniensis* (Fig. 18), the forewing has a short costa, a 2-branched Sc, R with 3-4 branches, Rs with 2 main branches, M with 2 main branches and Cu with many branches; A is absent. In the hindwing C seems to be absent, Sc is unbranched, R is 2-branched (R1 and R2+3), Rs is 2-branched, M arises from the stem of Rs and is multi-branched, Cu has numerous branches (as in the forewing) and A is well developed with numerous branches lodged in an anal lobe.

In the forewing of *Archotermopsis wroughtoni* (Termopsidae, Fig. 19), C is long (thick costal margin of authors) and Sc Short; R is 3-branched; Rs with 6-7 branches, M with 3-4 branches, Cu with 6 branches; A is absent. The hindwing is almost similar, but a short A is also present. There is a reticulum all over the membrane. The condition in *Anacanthotermes macrocephalus* (Hodotermitidae) is nearly similar.

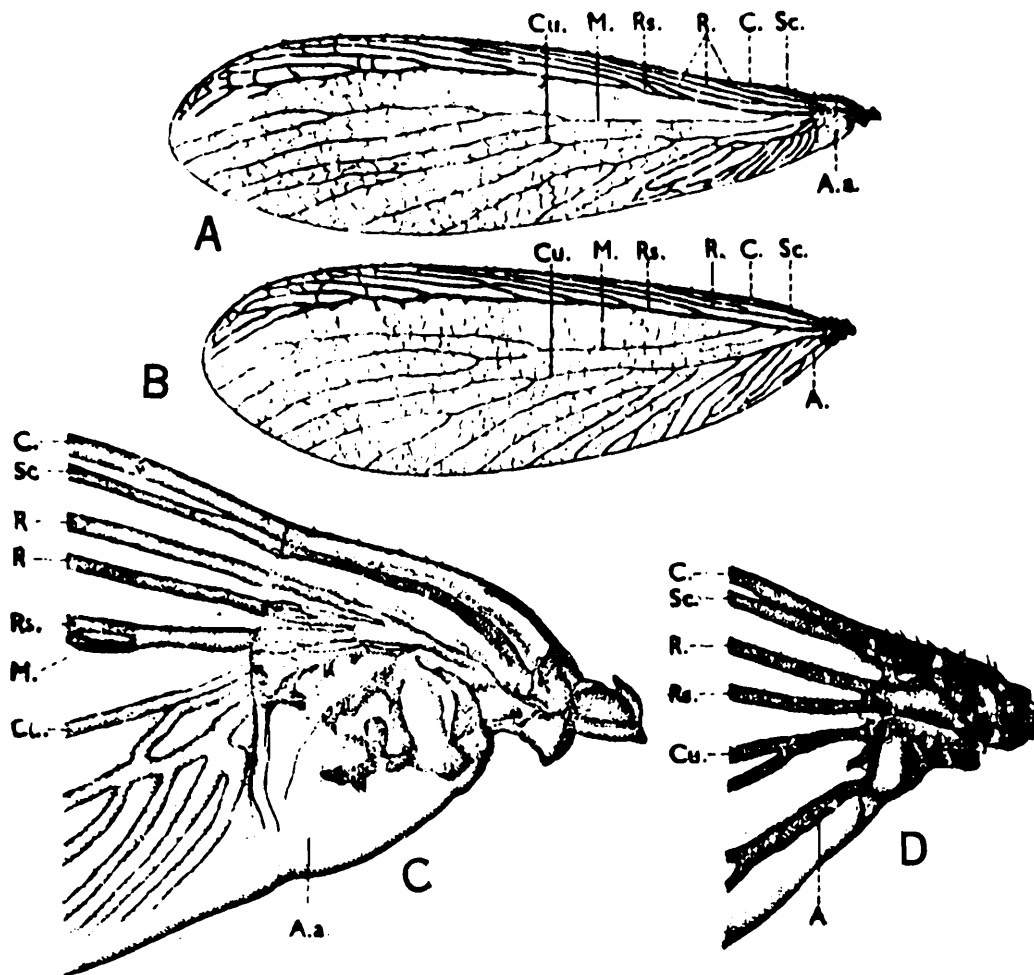

Fig. 19. *Archotermopsis wroughtoni*, wings. (A) Forewing. (B) Hindwing (C) Basal part of forewing. (D) Same, hindwing.

A. a., anal area; rest as in Fig. 18

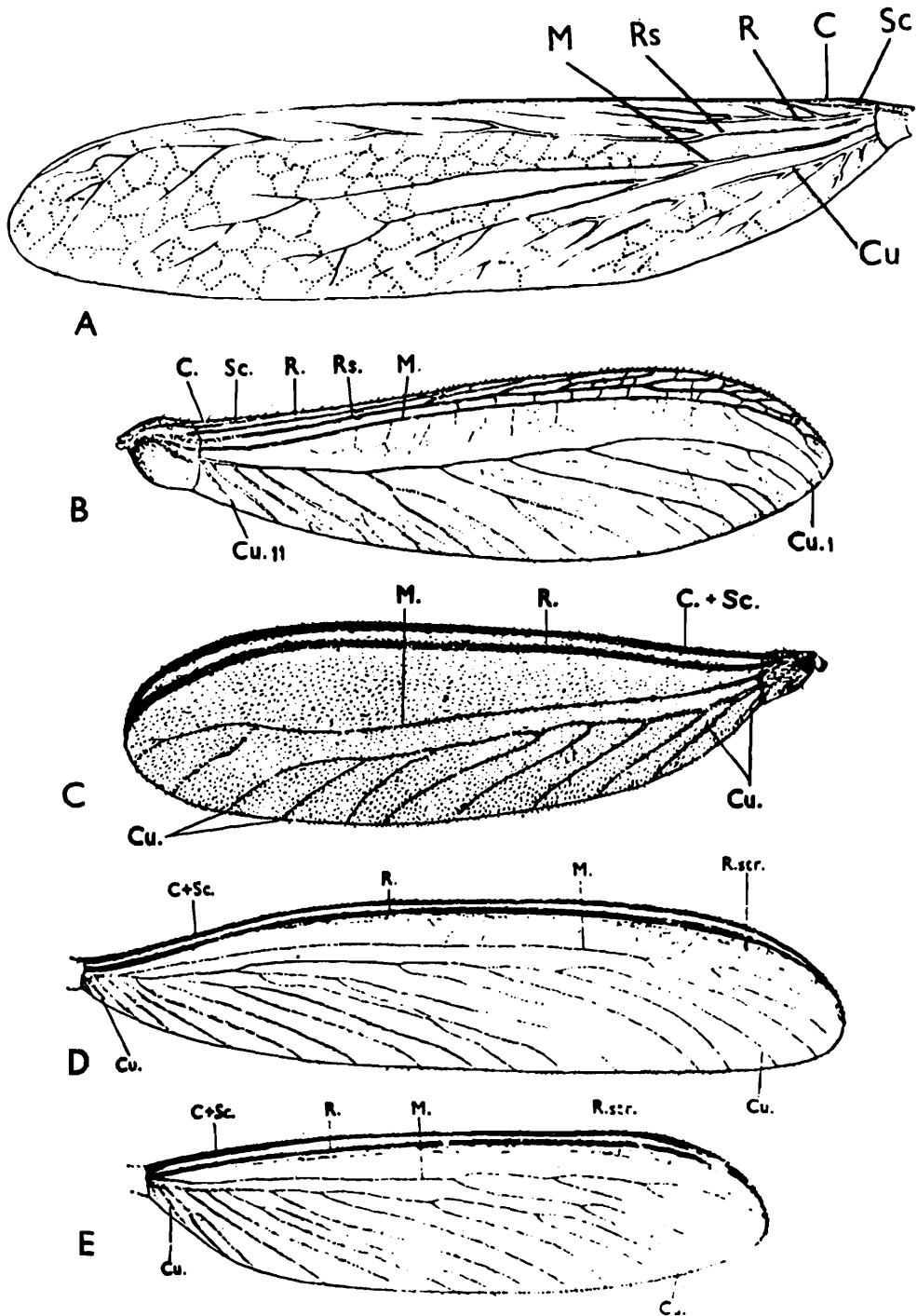
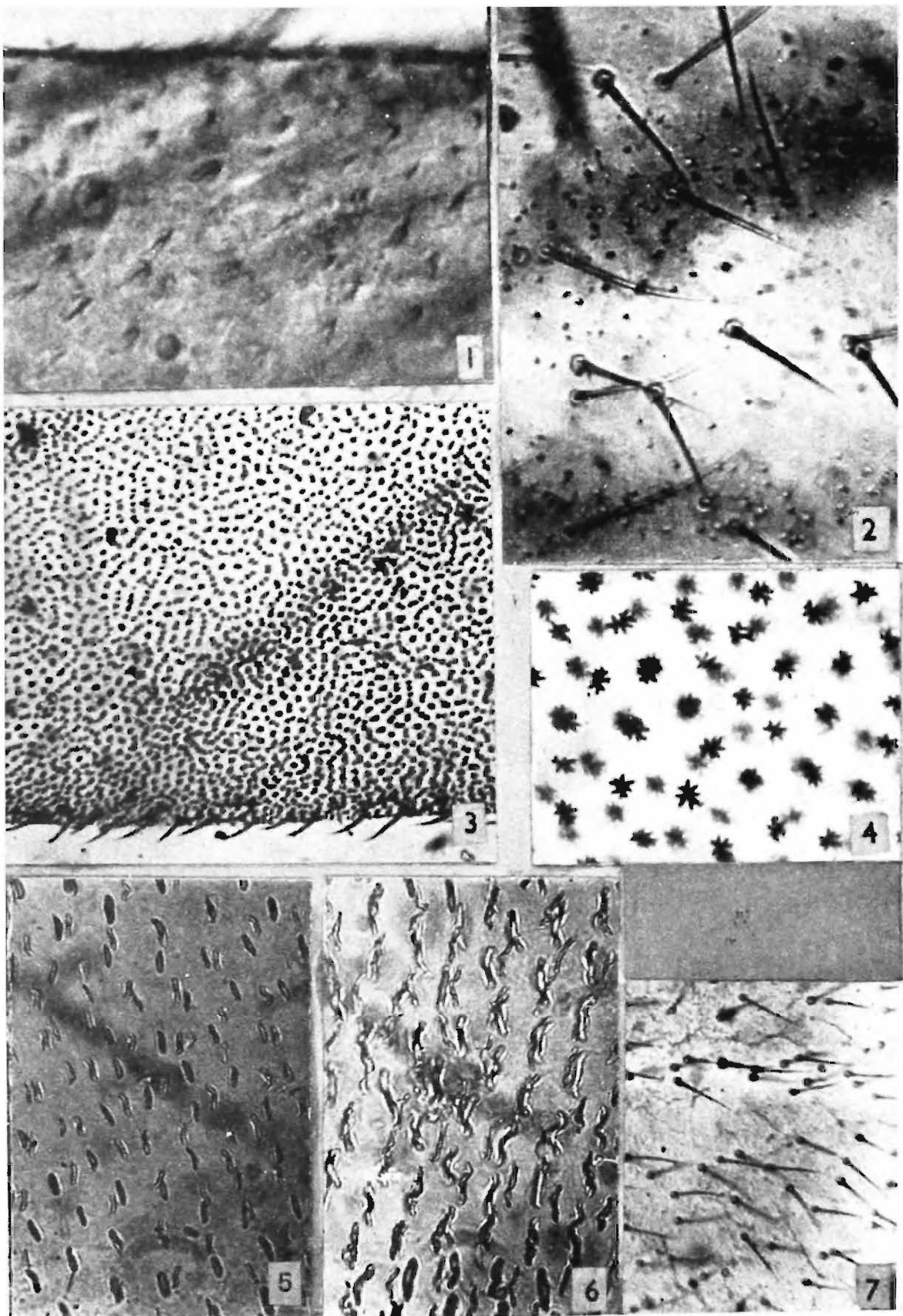

Fig. 20. Wings of some termites: (A) *Anacanthotermes macrocephalus*, forewing. (B) *Neotermes buxensis*, forewing. (C) *Coptotermes formosanus*, forewing. (D) *Odontotermes microdentatus*, forewing. (D) Same, hindwing. R. str., radial streak; rest as in Fig. 18.

PLATE 1



Photomicrographs (light microscope) of wing surfaces of termites to show microsculpturing; greatly magnified. 1. *Tenuirostritermes tenuirostris*. Pointed papillae near anterior margin. 2. *Coptotermes amanii*. Pimpules and hairs. 3. *Speculitermes silvestrii*. Micrasters and hairs (low magnification). 4. *Subulitermes kirbyi*. Micrasters (high magnification). 5. *Allodotermes schulzei orientalis*. Simple, one-armed micrasters; a few 2-armed (V-shaped). 6. *Odontotermes obesus*. Thin, subvertical rods. 7. *Syntermes territus*. Hairs.

PLATE 2

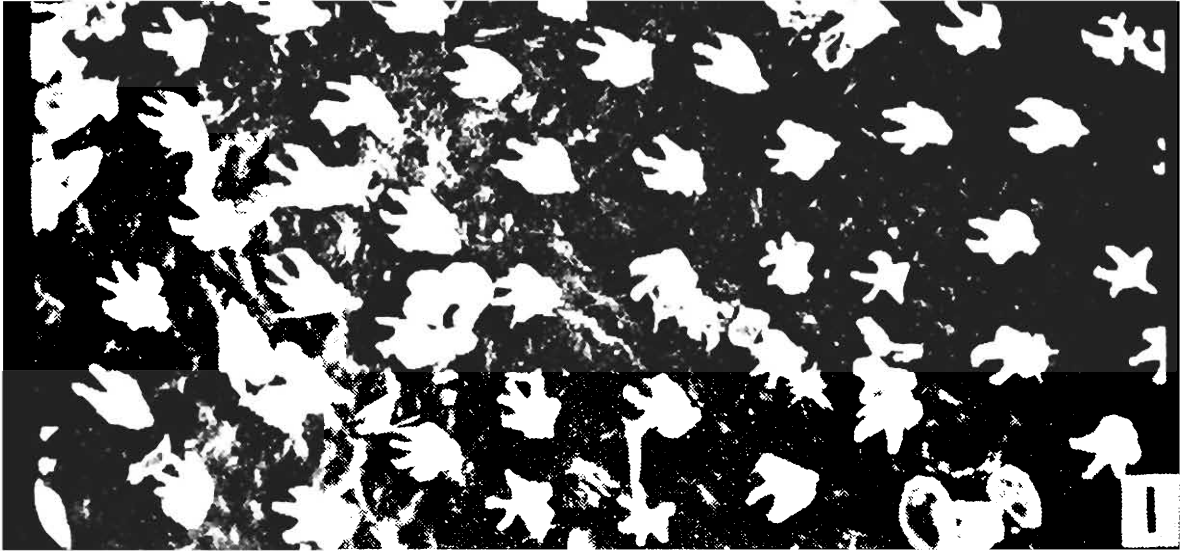

*Heterotermes indicola*. Scanning electron micrographs of upper surface of forewing membrane, to show micrastrer. (Ex Roonwal 1985.) 1. 1200 x. 2. 2400 x.

PLATE 3

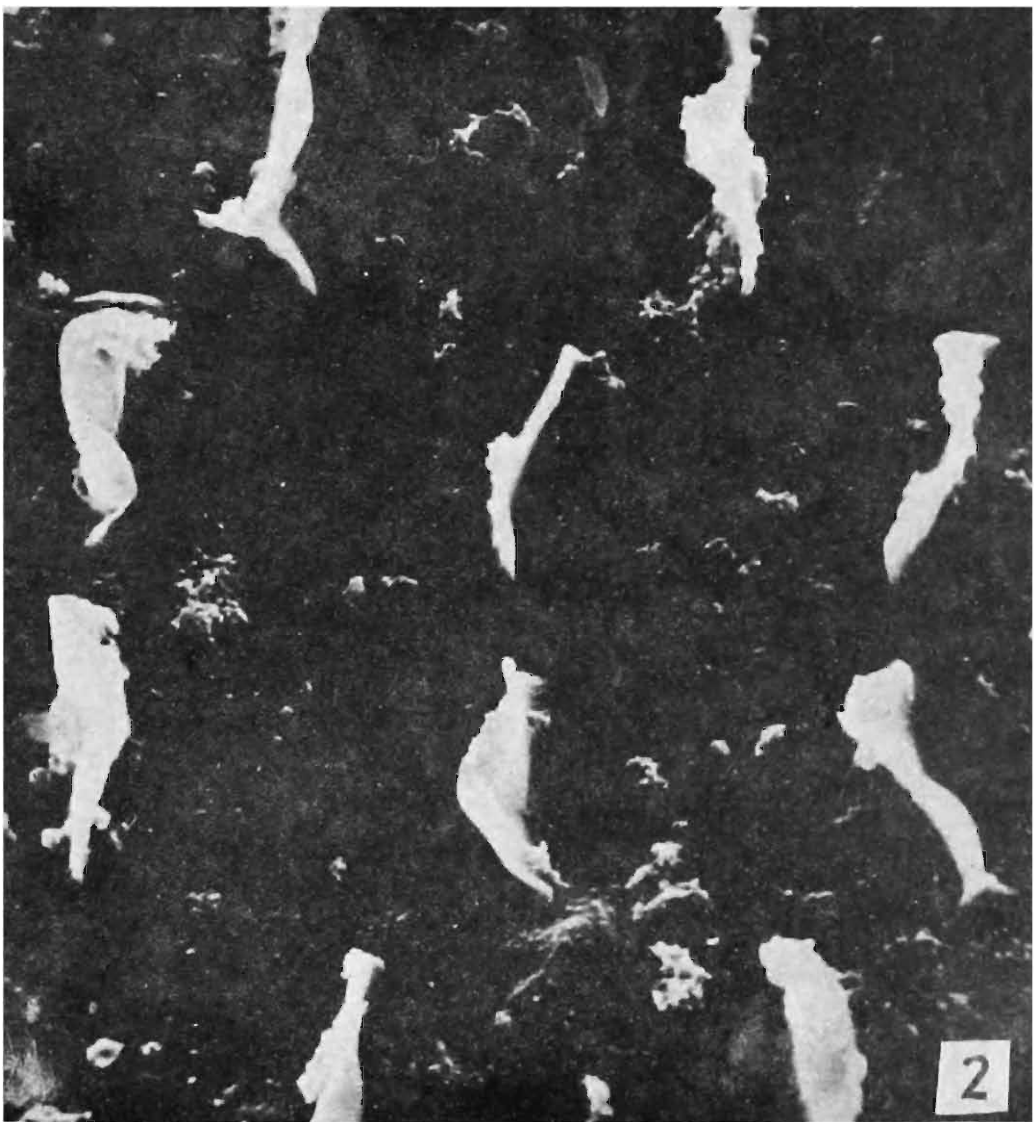

*Odontotermes obesus*. Scanning electron micrographs of surface of forewing, to show microsculpturing (rods). 1. 600 x. 2. Same, more magnified. 2400 x.

PLATE 4

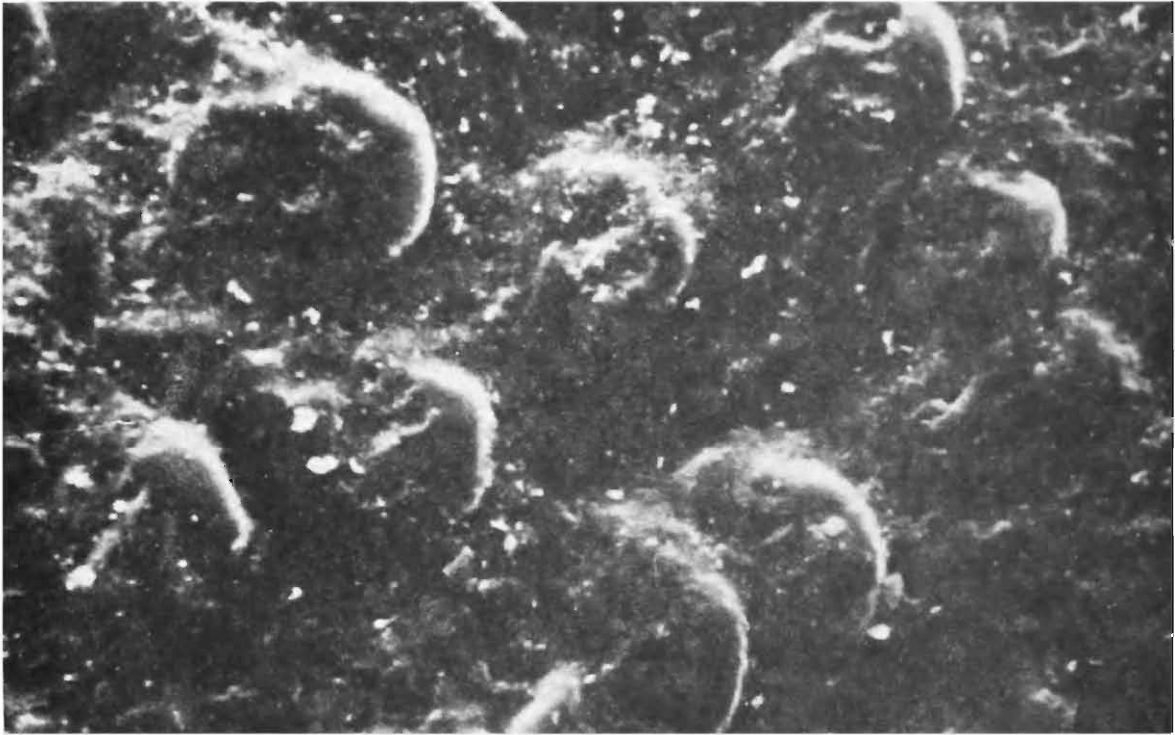

1

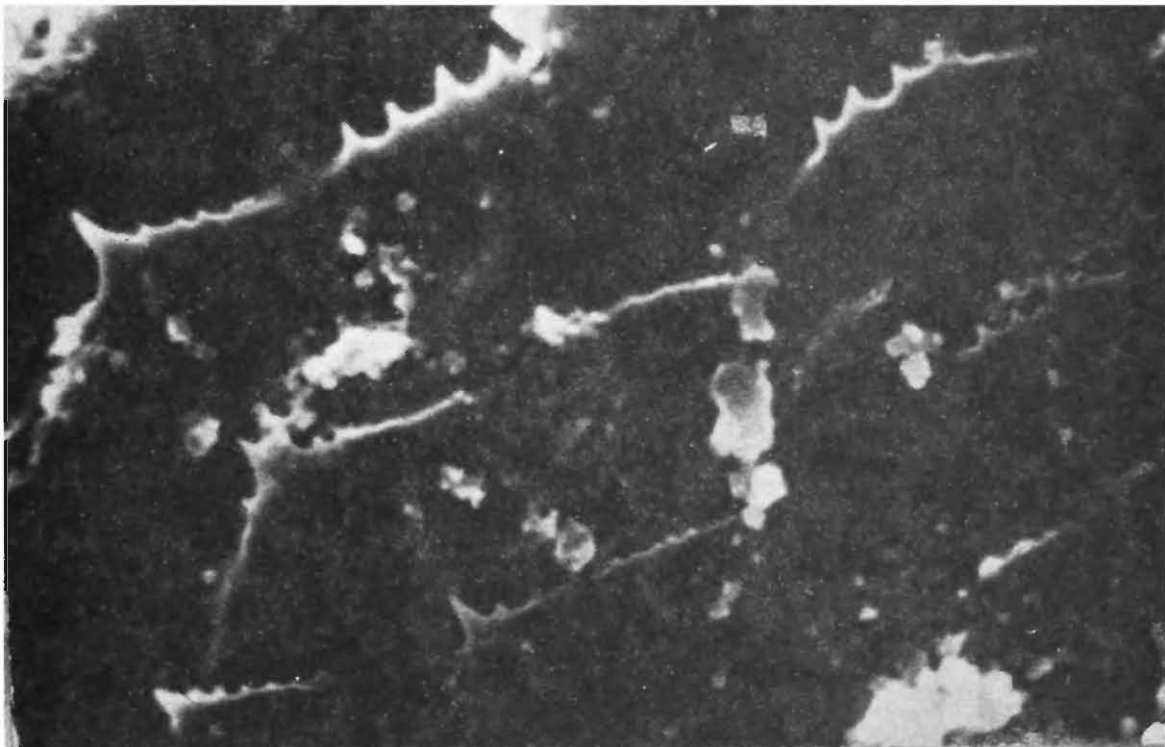

2

Scanning electron micrographs of surface of forewings, to show microsculpturing.

*Bifiditermes beelsoni* (Kalotermitidae). Tubercles. 1000 x. 2. *Stylotermes faveolus* (Stylotermitidae). Arrowheads. 5000 x.

In the forewing of *Neotermes buxensis* (Kalotermitidae) C and Sc are short, R is unbranched, Rs is 5-branched, M is 2-or 3-branched, C 10- or 11-branched, and A absent. In the hindwing, C and Sc are fused, R is unbranched, Rs and M have a common origin, Rs is 6-branched, M 2-branched, Cu about 14-branched, and A is absent.

In the remaining families there is a marked reduction of veins, the wings being characterised by the presence of a pair of parallel, thick, unbranched, heavily sclerotised veins at the anterior margin (the most anterior one variously interpreted as C+Sc or Sc+R, and the next one as R or Rs). The next ones are the branched M and the multi-branched C; A is absent. In some cases (*Odontotermes*) just below the R there is a faint, vein-like streak, the 'radial streak' (the subcostal streak, "Subcostalstrich", of Holmgren 1913 b). These veins are sometimes so thin and faint as to be hardly visible and their course can only be traced with the aid of a row of hairs which overlie them.

The whole problem of wing venation is in need of careful revision.

(b) Wing microsculpturing (Figs. 21-25; and Pls. 1-4) Wing microsculpturing provides an important and easily observable supplementary character in termite taxonomy. Since it has been established only in recent years, a somewhat detailed account is called for. In the older systematic literature, and even in some recent publications, there is only casual mention of the presence of minute structures on wing surfaces. These structures were variously and vaguely designated as tiny papillae, punctations, rounded punctations or micrasters, pimple-like pigmented nodules, papillae, pigmented granules, etc. The information was imprecise, without mention of shapes, sizes, locations and numbers, and there were no illustrations.

The first illustrations were of tubercles in some Kalotermitidae by Roonwal and Sen-Sarma (1960), followed by a detailed account of rods in some Macrotermitinae by Roonwal and Chhotani (1967b). This was followed by a series of papers by Roonwal and co-workers on all groups of termites. Practically the entire information we have today will be found in the following accounts Roonwal (1977a, 1981a, 1982a, 1983b, c, 1985, a-d), Roonwal and Chhotani (1967), Roonwal, Chhotani and Verma (1981), Roonwal and Rathore (1977, 1978, 1982), Roonwal and Sen-Sarma (1960), Roonwal and Verma (1980a, b, 1983), Roonwal, Verma and Rathore (1974, 1980), and Roonwal, Verma and Thakur (1979a, b).

At least eight different types of cuticular microsculpturings (in addition to hairs) are now known to occur in enormous numbers on both the upper and lower surfaces of wing membranes (on the basal or humeral scale they are considerably distorted by lumping, shortening, etc., vide Roonwal and Rathore, 1982). According to their shape and general appearance, they have been termed as papillae, arrowheads, tubercles, spearheads, pimpules, micrasters, microsetae and rods (Figs. 21-24; and Pl. 1-4). Their size varies from ca. 0.5-24  $\mu\text{m}$ , and the density from a few hundred to over 12500/ $\text{mm}^2$ . There may be as many as over half a million on a single wing surface, and thus over a million on both surfaces. The apices of papillae, arrowheads, tubercles and spearheads are directed towards the distal end of

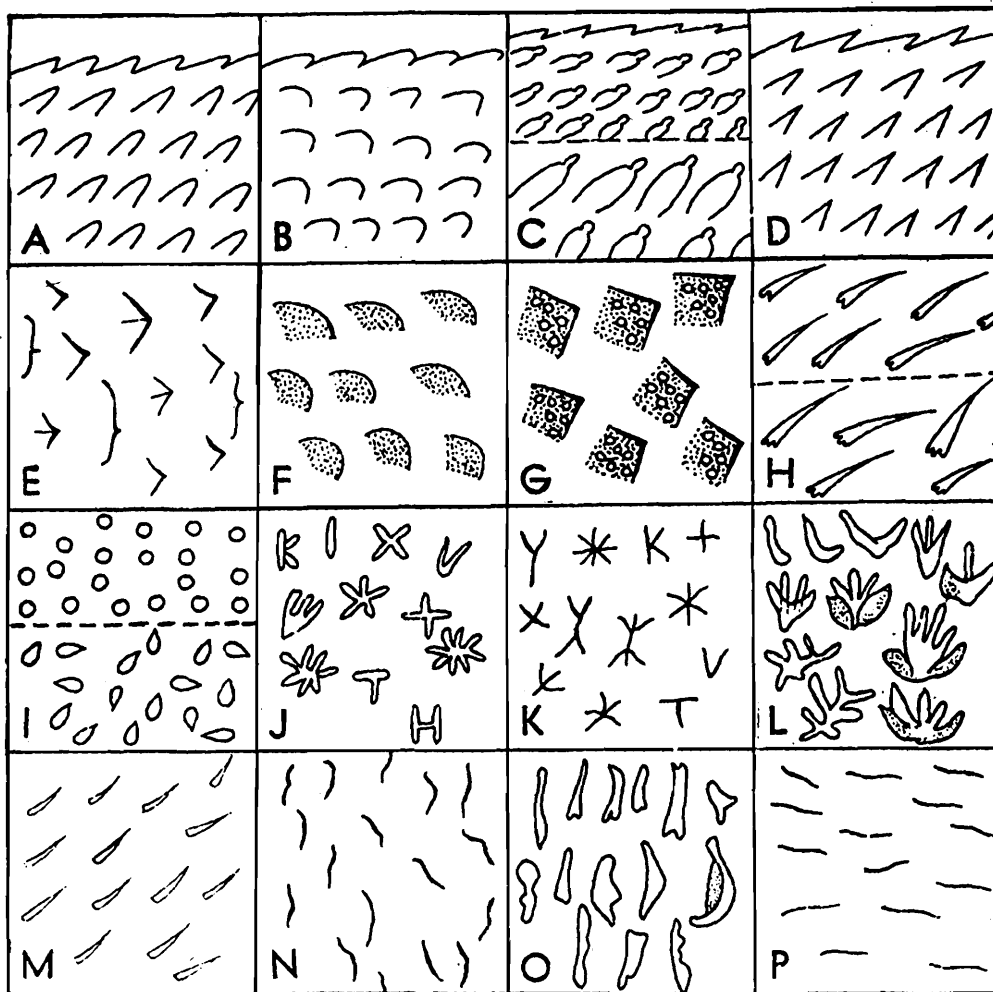

Fig. 21. The main types of microsculpturing elements found on termite wing surfaces (light microscope images except where otherwise stated). (A) Papillae, finger-shaped. (B) Same, subcrescentic. (C) Same, nipple-shaped. (D) Same, pointed and thorny. (E) Arrowheads. (F) Tubercles, subcrescentic. (G) Same, angular. (H) Spearheads. (I) Pimpules. (J) Micrasters, thick (K) Same, thin (L) Same, scanning electron microscope images. (M) Microsetae. (N) Rods, subvertical. (O) Same, scanning electron microscope images. (P) Rods, subhorizontal.

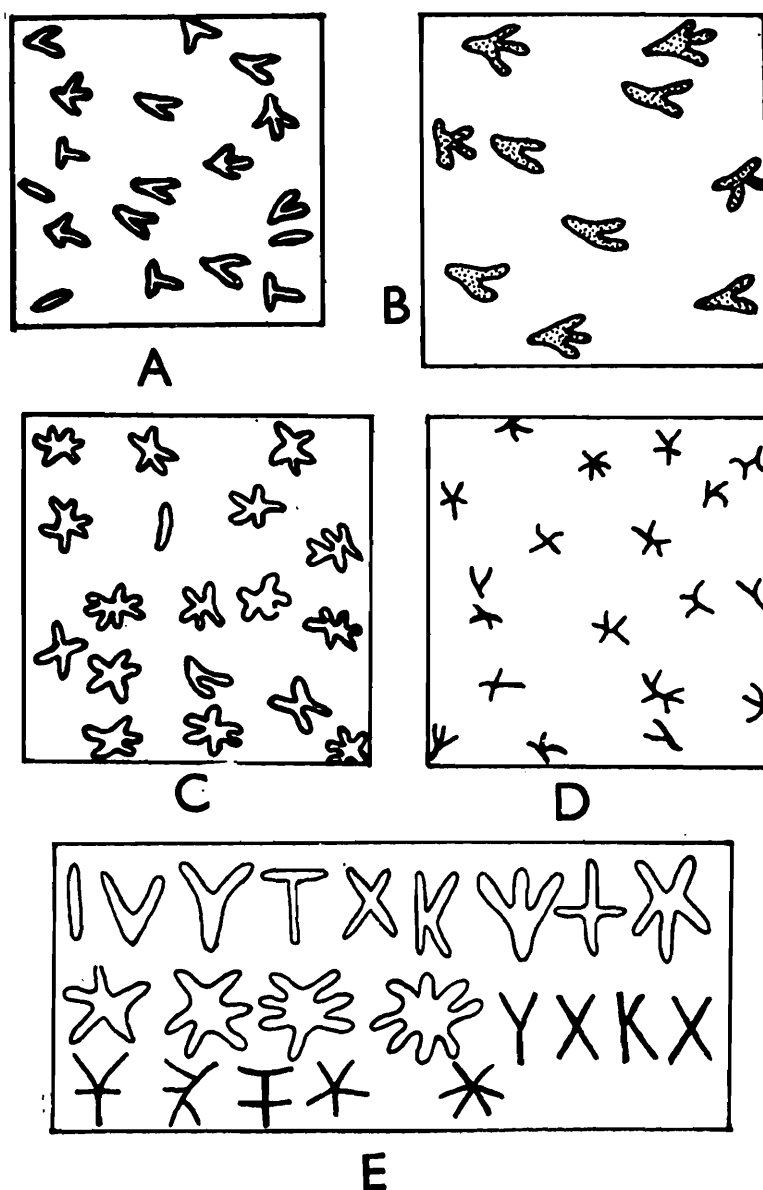
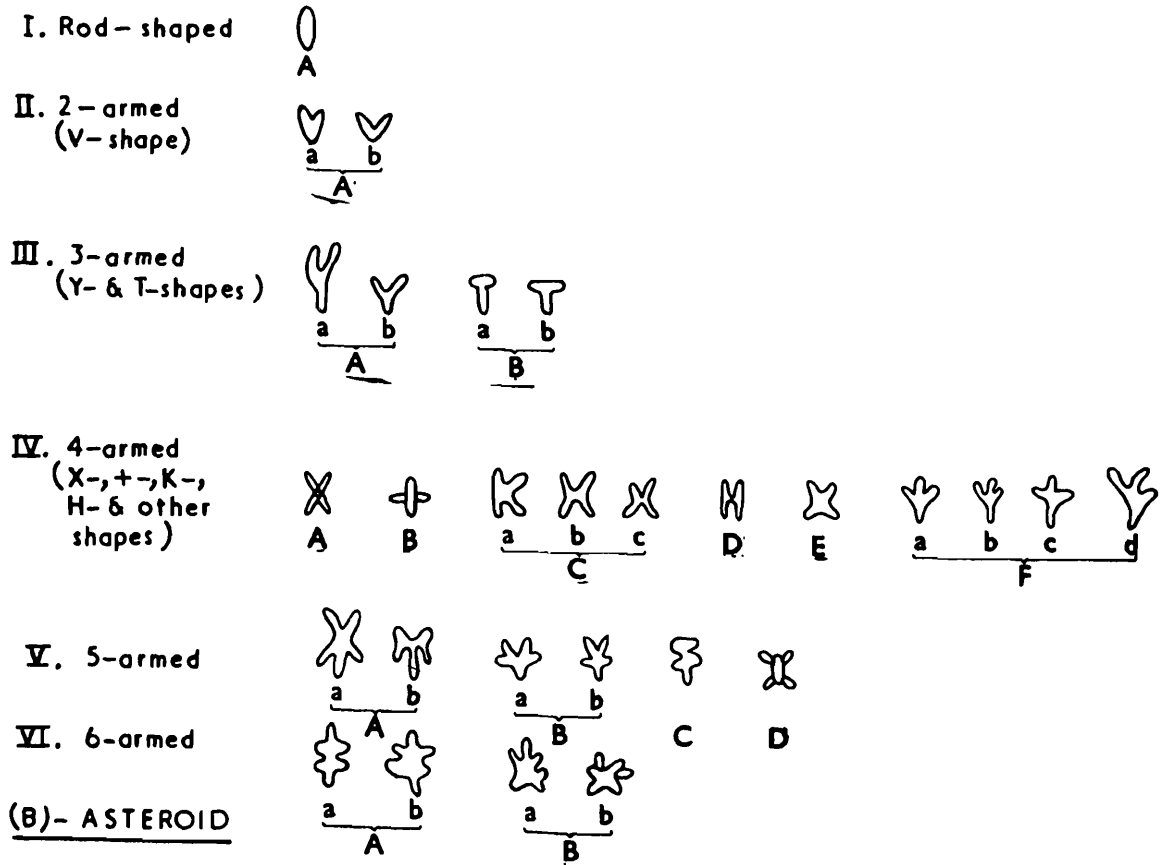

Fig. 22. Types of micraster arrangements in termites. (A) Simple, clear and thick; nonasteroids (*Anoplotermes pacificus*). (B) Simple, dark and thick (*Ruptitermes silvestrii*). (C) Simple to complex and thick; both nonasteroids and asteroids (*Heterotermes gertrudae*). (D) Simple to complex, thin (*Eremotermes fletcheri*). (E) The more common types, arranged from simple to complex; both thick and thin kinds.

the wing, while the other structures are not so directed. Papillae are universally present in all termites; the remainder may be present or absent, not more than 2 or 3 types being present simultaneously in a species. The other characteristics of the various types are as follows (for more details, vide Roonwal 1983c) :

(i) Papillae : Longish, papillate, pale yellow to deep brown, hyaline. Of two main types, viz., finger-shaped or tongue-shaped with a round tip (sometimes nipple-shaped and subscrenentic); and pointed and thorny or

(A) - NON-ASTEROID



(B) - ASTEROID

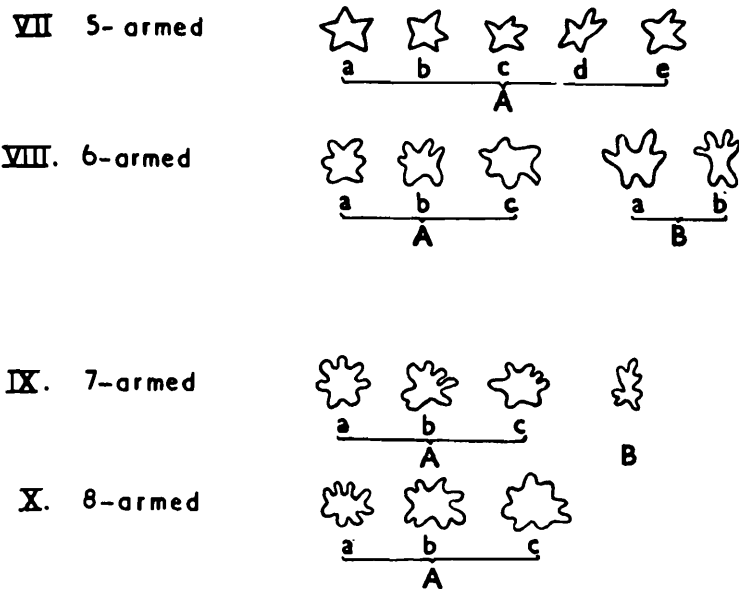
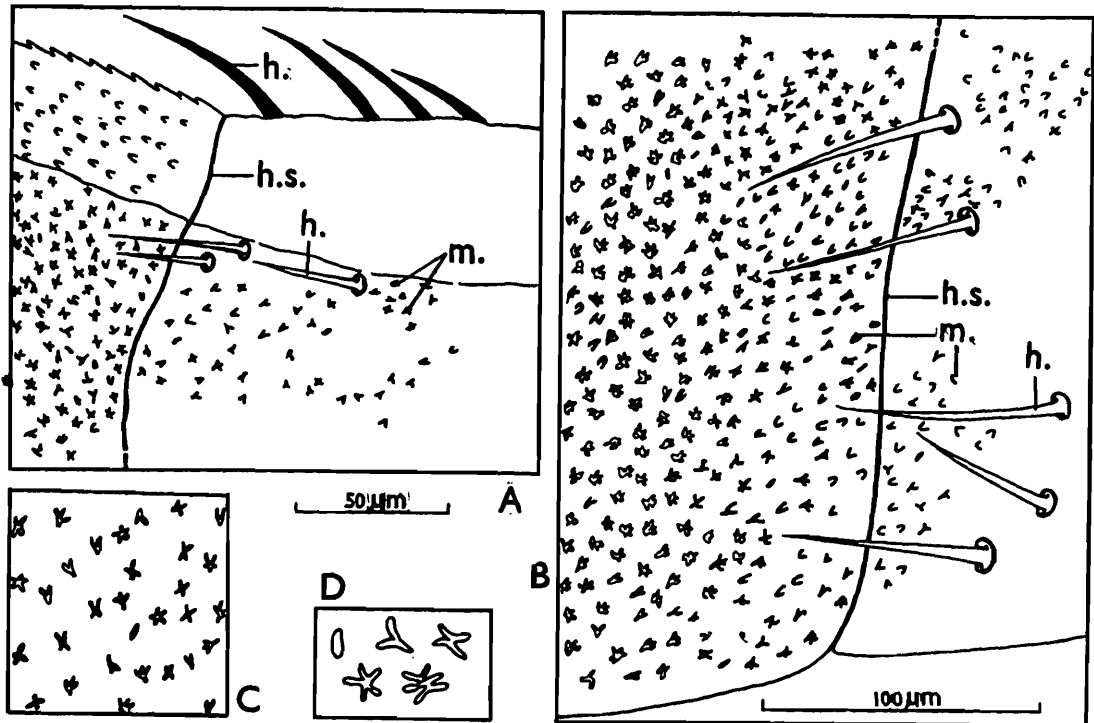

Fig. 23. Categories (asteroid and nonasteroid) and types (I-X) of micrasters on wing-membranes of *Microtermes* and *Angulitermes*. (Ex Roonwal, et al. 1974).



**Fig. 24.** Modification (shortening and lumping) of micrasters on basal scale of wing in termite (*Microcerotermes raja*, left forewing). (Ex Roonwal and Rathore 1982). (A) Upper part of scale (right portion in figure). (B) Same, lower portion of scale. (C) Typical micrasters on middle of wing membrane. (D) Same, enlarged and re-arranged. h., hairs; h.s., humeral suture; m., micrasters.

spiky. Size small ( $1 \mu\text{m} \times 0.5 \mu\text{m}$ ) to large ( $3\text{-}12 \mu\text{m} \times 2.6 \mu\text{m}$ ). Usually present in one or more rows on and near the anterior and posterior margins of wings. Density low to high (ca. 2000-12500/mm<sup>2</sup>). [Papillae also occur on tibial spines and spurs in some termites, vide supra.]

(ii) **Arrowheads** : Small, sharply angular, > - or } - shaped, hyaline, colourless to pale brown. Usually with 2 arms, sometimes with a third, central arm. Size varying,  $3\text{-}9 \mu\text{m} \times 4\text{-}23 \mu\text{m}$ ; density low, ca. 1800/mm<sup>2</sup> or lower. Generally present in one or more rows on veins.

(iii) **Tubercles** : Large, granular bodies with dark, deep brown, hyaline, crescentic or angular margins (hence two types of tubercles: crescentic and angular), and a subround, granular, colourless mass. Granules fine in crescentic tubercles and both fine and large (the latter looking like pimpules) in angular tubercles. Size small to large (diameter 12-24  $\mu\text{m}$ , height 1-7  $\mu\text{m}$ ). Density low (400-500/mm<sup>2</sup>) in angular tubercles, higher (2600-6300/mm<sup>2</sup>) in the other type. Crescentic tubercles chiefly present in sublunar rows on the veins; angular ones chiefly on the membrane.

(iv) **Spearheads** Slightly curved, pointed and hair-like (length 6-23  $\mu\text{m}$ , density ca. 4000-6000/ $\text{mm}^2$ ) bodies with either incurved, tripod-like or jagged base which is very wide. Present all over except in the region of the papillae.

(v) **Pimpules** : Minute, colourless, hyaline, round to slightly pointed structures; sometimes vase-shaped. Size 1-4  $\mu\text{m} \times$  1-6  $\mu\text{m}$ . Density low to high, 900-8800/ $\text{mm}^2$ . Present all over wing except in the region of the papillae.

(vi) **Micrasters** (Figs. 21-24; and Pls. 1 and 2) : Small to large bodies, hyaline, colourless to deep brown. Of two categories nonasteroid, with 1-6 arms and shapes like I, V, Y, +, X, K, T, E, H, etc.; and asteroid, with 5-8 arms and shaped like an asterisk (\*). In scanning electron micrographs, they appear to be flower like or vase-shaped; with 0-4 arms sprouting out. Arms thin or thick. Density moderate to high (ca. 3300-11600/ $\text{mm}^2$ ). Generally present all over membrane except in the region of the papillae; usually arranged in circles, ovals and spirals, with one or more micrasters at the centre (Pl. 1, Fig. 3).

(vii) **Microsetae** : Thin, tiny, setae-like, pointed, hyaline, without a basal articulation (differing from hairs in being very small, length 8-16  $\mu\text{m}$  vs. 35-210  $\mu\text{m}$ ); base narrow (cf. spearhead). Density ca. 5000-6000  $\text{mm}^2$ . Present all over membrane except in the region of the papillae.

(viii) **Rods** : Short to long (2-16  $\mu\text{m}$ ), thin, stringy, hyaline, colourless, weakly curved. Of two types, viz. either subvertical or subhorizontal. Density low to high (ca. 2900-8700/ $\text{mm}^2$ ). Present all over membrane except in the region of the papillae.

Hairs on wings (setae or macrotrichia of authors) are not strictly a part of microsculpturing but may be mentioned here. Hyaline, colourless to deep brown, with a broad base and a pointed tip; basally articulated. Are always present on margins in greater or lesser abundance. On membrane, either present or almost absent, sometimes present in great numbers (up to ca. 5000/ $\text{mm}^2$ ). Are generally few in primitive families, fairly abundant in the intermediate ones, and again generally few or absent in the highest family (Termitidae) but sometimes abundant.

Scanning electron microscopic studies (Pls. 2-4) : While the structures as viewed under the light microscope look as given above, the scanning

electron microscope reveals more details. For instance, what appeared as simple Vs with one or more central arms, are in reality leafy, sheath-like bodies of relatively thin, gauzy material enveloping, like a flower, the central 1-4 pistil-like arms. (Pl. 2, *Heterotermes indicola*, vide Roonwal, 1985b).

**Systematic importance :** The broad evolutionary grouping is seen in Fig. 25. Microsculpturing provides an important and easily observable character and often helps in the separation of allied genera and species. Thus, *Odontotermes* and *Hypotermes* (closely allied genera) have long, thin rods, while *Microtermes* of the same subfamily (Macrotermitinae) have short and thicker rods and simple V-shaped micrasters. In the Amitermitinae, genus *Eremotermes* has thin, stringy micrasters, while *Microcerotermes* has thick ones. In *Heterotermes gertrudae* (Rhinotermitidae) the papillae are finger-shaped, while in the closely-allied species, *H. indicola*, they are pointed and thorny.

Microsculpturing is best represented on the wing-membrane. On the wing scales it gets distorted by reduction and coalescence of the micraster arms and other such changes (Fig. 24). But here too, the presence or absence of the structures characteristic of the species, e.g., the presence or absence of rods, micrasters, etc., can be established (vide Roonwal and Rathore, 1982).

The occurrence of a thick carpet of microsculptures on termite wings has important biological and ecological consequences. These structures, occurring in hundreds of thousands on a wing, add enormous dead weight to the latter, and also make the wing surfaces highly rugose, thus greatly reducing their aerodynamic efficiency. As a consequence, termite flight is slow and erratic. This, in turn, prevents migration of the winged reproductives to long distances by their own intrinsic effort.

Microsculpturing is an essential character of the order Isoptera, a feature which has been incorporated in its definition as given above.

**Microsculpturing in allied orders :** Limited information is available on wing microsculpturing in orders allied to the Isoptera. In the small order Zoraptera (where too, as in the Isoptera wings are shed at a basal suture) information is available for a single species, *Zorotypus hubbardi* Caudell (Roonwal, 1983c). The wing membrane is densely covered all over on both sides with small hairs (length ca. 15-60  $\mu\text{m}$ , density ca. 1030/ $\text{mm}^2$ ); there is

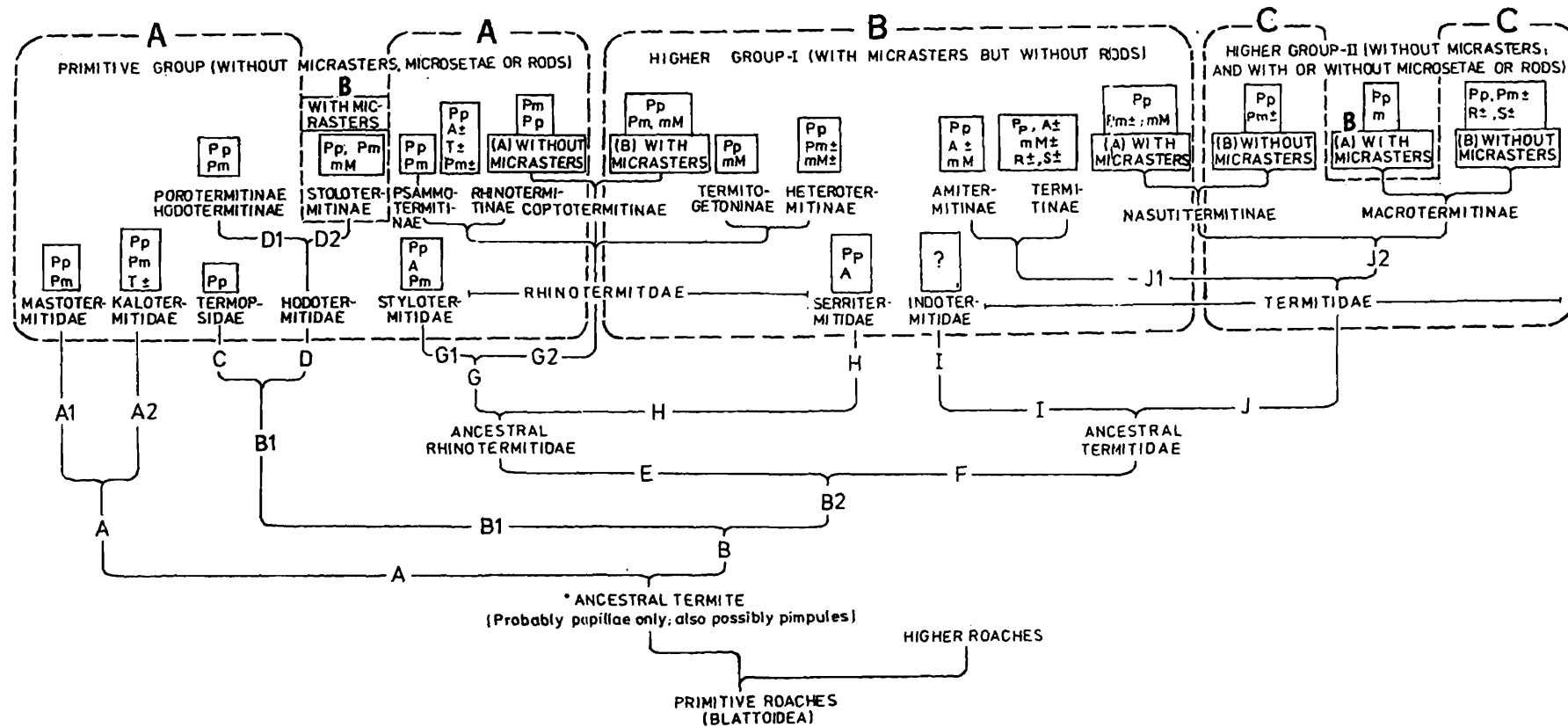

Fig 25. Evolution of wing microsculpturing in Isoptera, in three principal groups (A, B, C), the probable routes of descent (A, A1, A2, etc.), and the microstructures present in various families and subfamilies. (Ex Roonwal 1983c; revised regarding families Serritermitidae and Indotermitidae), (i) Serritermitidae: Microsculpturing is simple and consists of a few rows of small, tongue-shaped papillae on the anterior and posterior wing margins and a few rows of angular arrowheads in the anterior one-third of wings. It, therefore, belong to Group A, close to the 'A' part of the Rhinotermitidae. (Vide Roonwal and Rathore 1985, *Proc. Indian Acad. Sci, Anim. Sci*, 94, pp. 399-406.) (ii) Indotermitidae: Microsculpturing consists of a row of small, pointed papillae at the anterior wing margin and a dense carpet of minute, simple, nonasteroid microsters. It arose as a lone branch (with 3-segmented tarsi) from the initially 4-segmented Termitidae stock. (Vide Roonwal and Rathore, 1986, *Proc. Indian Acad. Sci, Anim. Sci*, 95, pp. 191-197.)

A, arrowheads; m, simple (nonasteroid) micraster; M, complex (asteroid) micrasters; Pm, pimpules; Pp, papillae; R, rods; S, microsetae; T, Tubercles. Note: For RHINOTERMITDAE read RHINOTERMITIDAE

no other type of microsculpturing. In the Embioptera (Roonwal and Rathore 1984) the wings are covered with three types of "hairy" structures, viz. microscimitars (with a swollen base and a curved, scimitar-like shaft, length ca. 16-150  $\mu\text{m}$ ; few in number), macrotrichia (length ca. 20-130  $\mu\text{m}$ ) and microtrichia (length 8-23  $\mu\text{m}$ ), the last ones being most numerous (ca. 1000-4050/ $\text{mm}^2$ ). In the Blattoidea (the cockroaches), in the single species studied (the small house cockroach, *Supella longipalpa* (Fabricius), Blattidae, Roonwal and Rathore 1983), eight types of microsculpturing elements, including hairs, have been found on wing and elytral surfaces; these are: pimpules, papillae, rods, microsetae, hairs (setae or macrotrichia of authors), polygons, parallel ridges and an irregular reticulum. These structures, however, are not as regular and dense as in the Isoptera.

### 5. *The Abdomen and Genitalia* (Figs. 26-30)

The termite abdomen is long and barrel-shaped, the posterior end narrowing strongly, and is divided into a number of annular segments whose number is primarily 11, but is reduced to 10, the last or 11th fusing with the preceding one during embryonic development. The segments are marked externally by a series of strongly sclerotic plates, the *terga* dorsally and the *sterna* ventrally, the two being joined laterally by distensible, membranous areas, the *pleura*. Occasionally, terga IX and X in females of some primitive species are welded to their corresponding sterna to form a ring-like sclerite. Each tergum and sternum is joined to the preceding and following sclerites by a membranous, distensible structure, the *intersegmental membrane*. In special cases, as in older physogastric queens, the pleura and the intersegmental membranes are stretched to several times their original dimensions to accommodate the vast number of eggs. The following account is summarised from Roonwal (1984).

The ten terga, I-X, are entire and are markedly uniform in the two sexes; tergum I is somewhat larger than the rest. Terga II-VIII are subequal and alike, and terga IX and X smaller. The last one is subtriangular, lies above the anus and forms the *epiproct* (also variously called decapygidium, pygidium, supraanal plate and subanal plate).

There are 10 sterna, 1-10. Sternum 1 is often extremely reduced or absent, and in general only sterna 2-10 are well developed and clearly visible. Sterna 2-6 are subequal and alike in the two sexes, but 7-10 differ and will be considered separately.

The first eight abdominal segments carry a pair of spiracles (1-8), one on either side, primarily lodged on the pleura. From this position, however, considerable variation may occur. Thus, in *Odontotermes obesus* (Kushwaha 1960b), spiracle 1 has shifted to the lateral margin of tergum I, the remaining ones retaining their original position. In *Anacanthotermes macrocephalus* (Gupta 1962b) and in *Zootermopsis angusticollis* (Sumner 1933) all of them have shifted to the terga; in the latter species spiracle 1 has been replaced by a tympanum-like structure.

The sclerotic position of the abdomen in a species can be summarised by the following *abdominal formula* as suggested by Roonwal (1984) where :

Sclerites which are totally atrophied are denoted with a zero (0) sign, while those which are membranous or reduced greatly or are not externally visible (being covered over by the sclerite of another segment) are bracketed. Conspicuously enlarged sclerites are printed in heavy type; sclerites which are divided into two clearly separated lateral halves are expressed as two pieces, e.g., 8 + 8, etc., and those which are clearly associated with one another are underlined together. Terga (T) are numbered in Roman numerals and sterna (S) in Arabic. A tergum and sternum when fused together to form a ring-like sclerite are enclosed in a common frame. The presence of cerci (c) and styli (s) are indicated against the corresponding sternum by these letters. An example will suffice:

Abdominal formulae of *Mastotermes darwiniensis* :

Alate	♂	T: I -II - III - IV - V - VI - VII - VIII -IX - X
Soldier	♂	_____
Worker	♂	S: 0 -2 - 3 - 4 - 5 - 6 - 7 - 8 - 9 <sub>s</sub> - 10+10 <sub>c</sub>
T: I -II - III - IV - V - VI - VII - VIII - IX - X		
Alate	♀	_____
		S: 0 -2 - 3 - 4 - 5 - 6 - 7 - (8+8) - (9+9) - 10 <sub>c</sub>
Soldier	♀	T: I -II - III - IV - V - VI - VII - VIII -IX - X
Worker	♀	_____
		S: 0 -2 - 3 - 4 - 5 - 6 - 7 - 8 - 9 <sub>s</sub> - 10 <sub>c</sub>

The last four abdominal segments, 7-10, are intimately connected with the genital apparatus and differ appreciably in the two sexes which will, therefore, be considered separately.

(i) *The male :*

Sternum 7, unlike females, is not enlarged and does not cover sterna 8 and 9. Sternum 8 may be entire (*Mastotermes*, *Archotermopsis*, *Odontotermes*) or divided into two lateral plates separated by the interpolating 9th. Sternum 9 is narrow but entire and posteriorly bears, near the median line, a pair of unsegmented styli which may sometimes be absent. Sternum 10 may be deeply cleft posteriorly, or is often divided into two lateral halves, and forms the *paraproct* (also called parapodial plate, podical plate, subanal plate); it carries laterally a pair of 1-to 8-segmented cerci. Males of *Hodotermes* and *Microhodotermes* are exceptional and resemble females; sternum 8 is enlarged and styli are wanting.

Two minor or accessory sclerites sometime occur in the intersegmental membrane between sterna 8 and 9. These are the narrow, paired *basivalvulae*, and behind them is the median, curved *secondary medisternite*.

The male gonopore lies on the intersegmental membrane between sterna 9 and 10. It is usually flush with the surface but sometimes lies at the tip of a papilla or an invaginated sheath which represents the inner or *penis* part of the aedeagus, and even this is generally wanting. A fully developed intromittent organ is never present.

Four ventral, median external openings may occur in the genital region, though all not simultaneously in the same species. These are, from front to back, in the order stated below : (i) Opening of a small, nipple-shaped organ or gland on sternum 8 (*Hodotermes mossambicus*). (ii) Opening of the sternal gland on the posterior part of sternum 9 (*Hodotermes mossambicus*, *Neotermes zuluensis*). (iii) The gonopore (opening of the ductus ejaculatorius) on the intersegmental membrane between sterna 9 and 10. (iv) Opening of the caudal glands, also on the intersegmental membrane between sterna 9 and 10 but behind the gonopore (*Neotermes zuluensis*).

(ii) *The female :*

In all females (and males of *Hodotermes* and *Microhodotermes* which resemble females in this respect), sternum 7 is greatly enlarged to form a *subgenital plate* (also called hypogynium and genital plate), and generally covers the next two sterna. Sterna 8 and 9 are narrow and may be either entire or divided into two well-separated lateral plates. They are generally invaginated over sternum 7 to form a deep cavity, the *vestibulum* (also variously called bursa copulatrix, genital cavity, genital chamber, interseg-

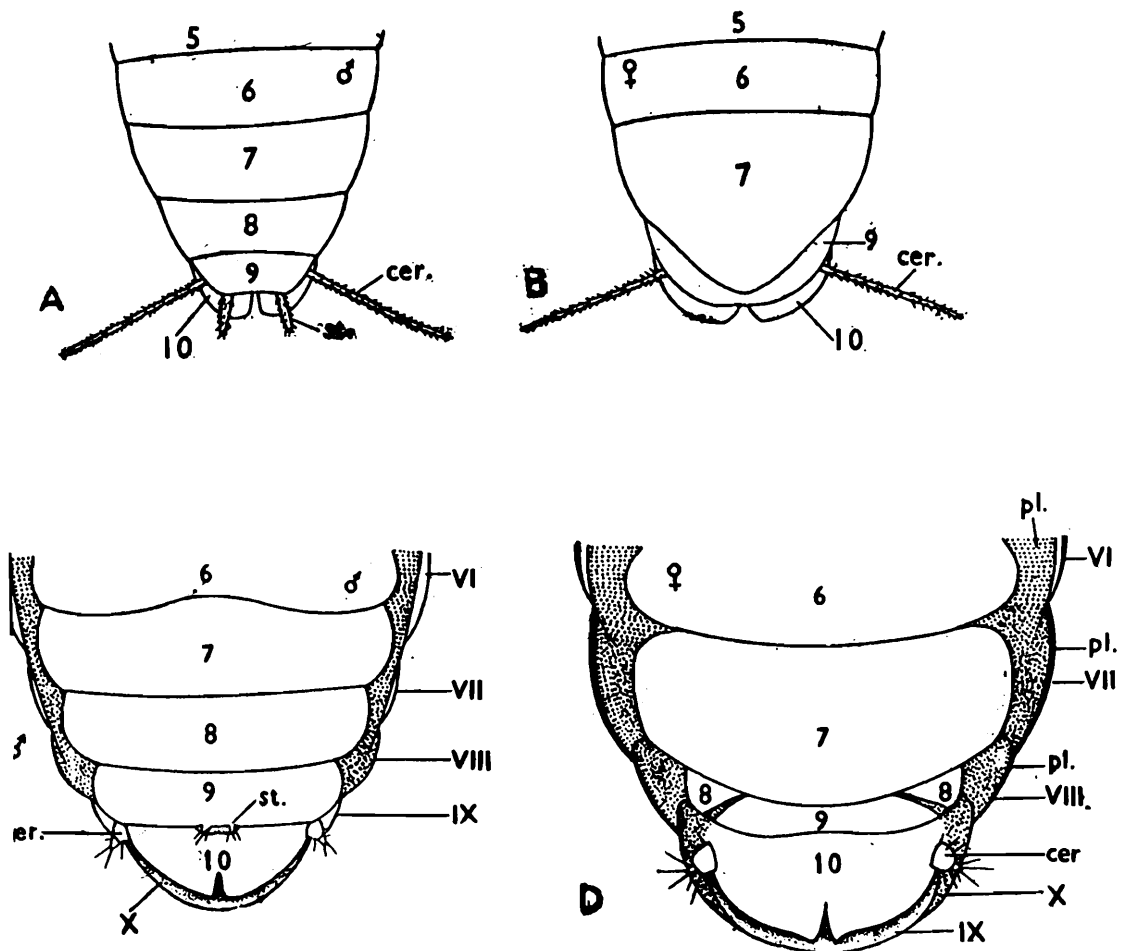

Fig. 26. Posterior abdominal sterna. (A) *Archotermopsis wroughtoni*, alate male. (B) Same, alate female. (C) *Odontotermes obesus*, alate male. (D) Same, alate female. VI-X, 6th to 10th terga; 5-10, 5th to 10th sterna; cer., cercus; pl., pleuron; st., stylum.

mental pouch, subgenital pouch, vestibule copulateur and vagina\*) which opens to the outside by a wide opening, the *ostium vestibulare*. The vestibulum may be divided into a narrow inner chamber, the *inner vestibulum*, and a wider outer chamber, the *outer vestibulum*. The vestibulum floor is formed by the intersegmental membrane between sterna 7 and 8 (which is sometimes prominently folded to form an *intersternal fold*, as in *Mastotermes*, *Archotermopsis*, *Zootermopsis*, *Tenuirostritermes*, etc.) and the roof by sterna 8 and 9, but these latter may sometimes lie almost wholly outside it. The dorsal wall of the intersternal fold may sometimes carry a *medial groove* (*Tenuirostritermes tenuirostris*). Sterna 9 and 10 are sometimes fused with the corresponding terga to form a ring-like sclerite.

\* The term 'vagina' is also used by authors for the common oviduct.

Unlike males, sternum 9 generally does not bear styli, except in certain *Hodotermitidae*. Sternum 10 is as in males, and carries the 1 to 8-jointed cerci.

In front of the posterior edge of the gonopore there is sometimes present a thin-walled cavity, the *progonoporal chamber*; and two blind pouches, the *first* and *second vestibular pouches*, which may sometimes open into the vestibulum roof.

Three minor sclerites occur as follows : A pair of narrow sclerites, the *basivalvulae*, in the intersegmental membrane between sterna 7 and 8, but probably belonging to the latter; and two median, curved, crescentic sclerites between sterna 8 and 9, viz., the *medisternite* and, behind it, the *secondary medisternite*.

The complete ovipositor, with all three valves, is present only in *Mastotermes darwiniensis* where it consists of three pairs of soft, almost

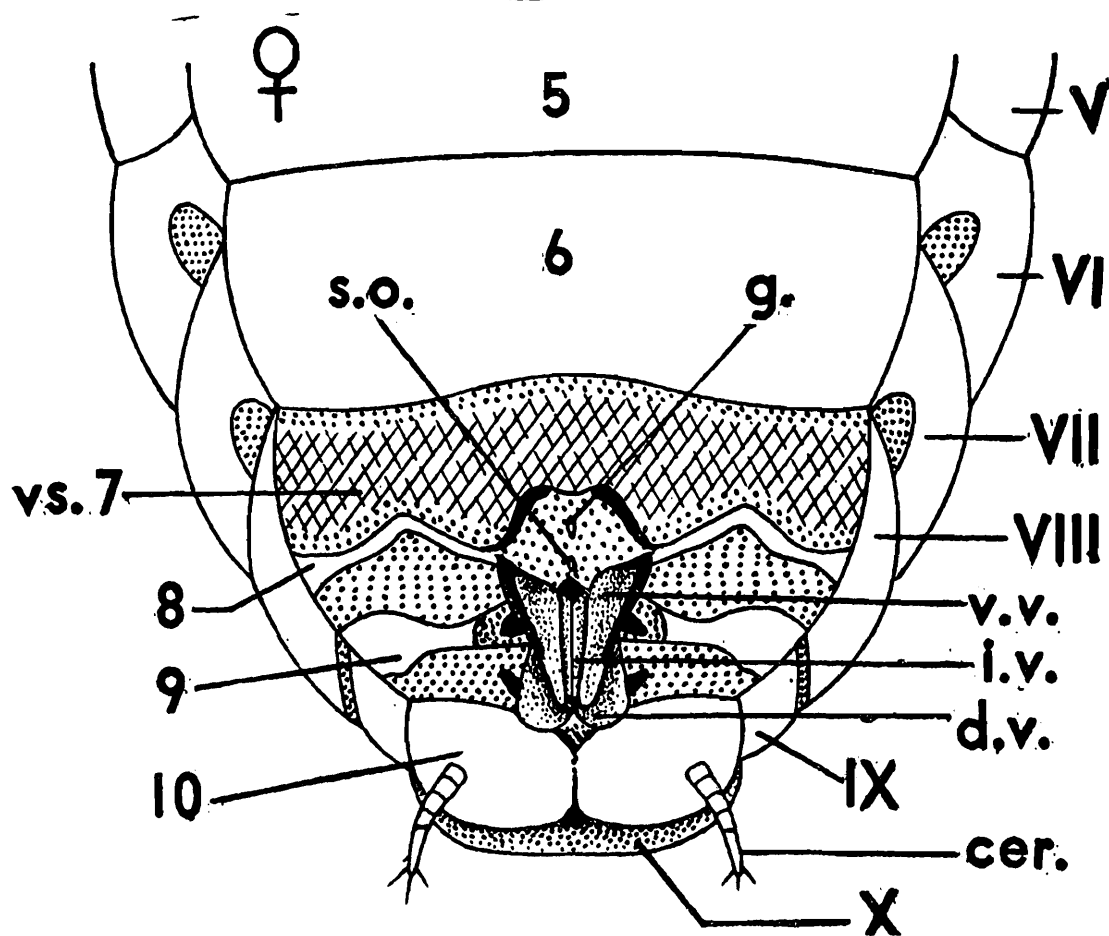

Fig. 27. *Mastotermes darwiniensis*, alate female. Posterior abdominal segments in ventral view, with sternum 7 (subgenital plate) removed to expose the ovipositor valves, etc. V-X, 5th to 10th terga, 5-10, 5th to 10th sterna; cer., cercus; d.v. dorsal valve; g., gonopore. (opening of common oviduct); i.v., inner valves; s.o., spermathecal opening; vs. 7, viscera beneath sternum 7, v.v., ventral valve.

unsclerotised *ovipositor valves*, viz., the *ventral* (first or anterior), the *inner* (second or posterior) and the *dorsal* (third or lateral) valves (Fig. 27). The ventral valves belong to sternum 8, the other two to sternum 9. From this condition there are various degrees of reduction, and in probably all the higher termites the ovipositor is completely wanting.

The *female gonopore* or the opening of the common oviduct (the so-called vagina of authors), lies near the anterior end of the vestibulum in the intersegmental membrane between sterna 7 and 8 (Holmgren's account, 1909, that in *Heterotermes tenuis* and some other unspecified termites the gonopores is paired, the two lateral oviducts opening by their own apertures, requires confirmation).

The *spermatheca* (receptaculum seminis) opens either on or just behind sternum 8, but may sometimes secondarily shift forward to the intersegmental membrane between sterna 7 and 8, e.g., in *Heterotermes tenuis*. (The claims of some authors that it opens into the oviducts is an error.) In some cases, the opening leads backward into a long, deep groove, the *spermatic groove* (or spermathecal furrow) which lies in the vestibulum roof.

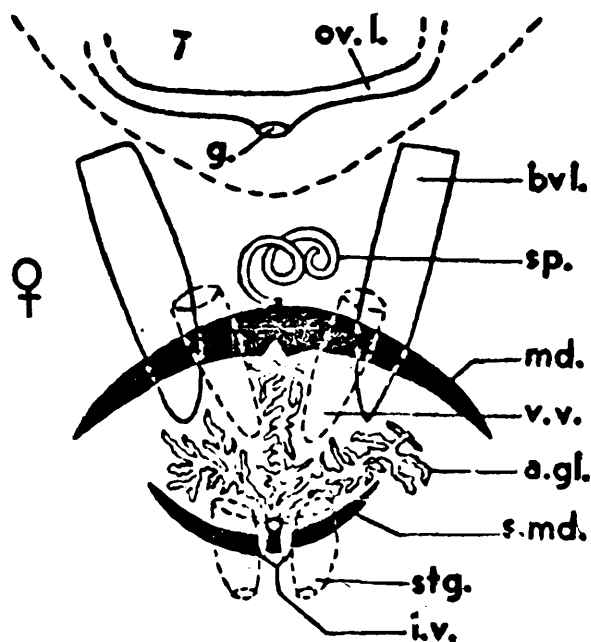

Fig. 28. *Mastotermes darwiniensis*, alate female. Vestibulum exposed, in dorsal view, to show the reproductive parts and associated structures. (Ex Geyer, 1951.)

7, seventh sternum; a.gl., accessory gland; bvl., basivalvula; g., gonopore; i.v., inner valve; md., medisternite; ov.l., lateral oviduct; s.md., secondary medisternite; sp., spermatheca; stg., styli; v.v., ventral valve.

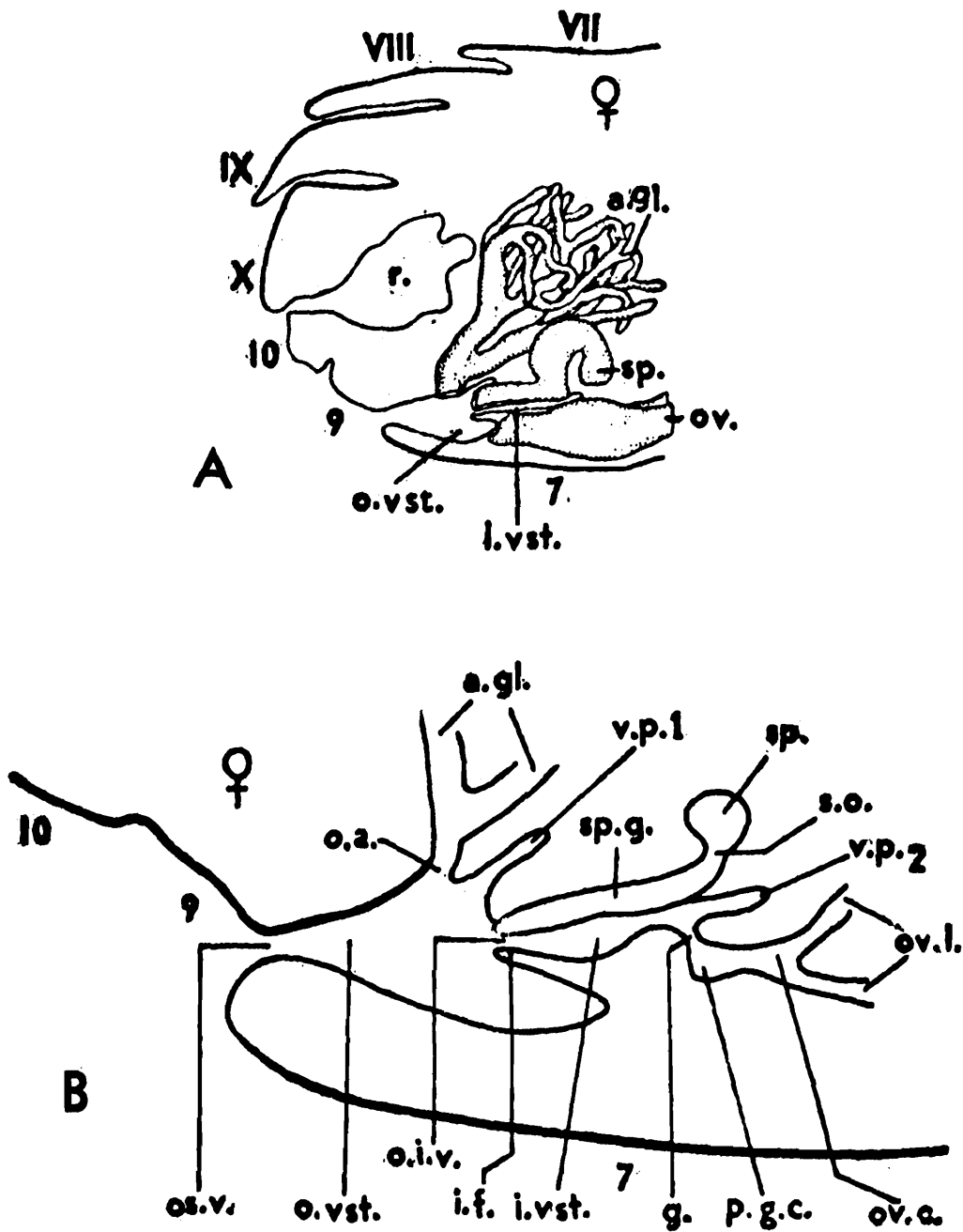

Fig. 29. *Tenuirostritermes tenuirostris*, alate female. Longitudinal vertical sections of the posterior abdominal segments, to show the relationships of the reproductive organs and associated structures. (A) Re-construction. (B) Simplified, semi-diagrammatic. (Ex Weesner 1955.)

VII-X, 7th to 10th terga; 7-10, 7th to 10th sterna; a.gl., accessory glands; g., gonopore; i.f., intersternal fold; i.vst., inner vestibulum; o.a., opening or accessory glands; o.i.v., opening of inner vestibulum; o.vst., outer vestibulum; ov., ovary; ov.c., common oviduct; ov.l., lateral oviduct; os.v., ostium vestibulare; p.g.c., progonoporal chamber; r., rectum; s.o., spermathecal opening; sp., spermatheca; sp.g., spermathecal groove; v.p.1, v.p.2, first and second vestibular pouches.

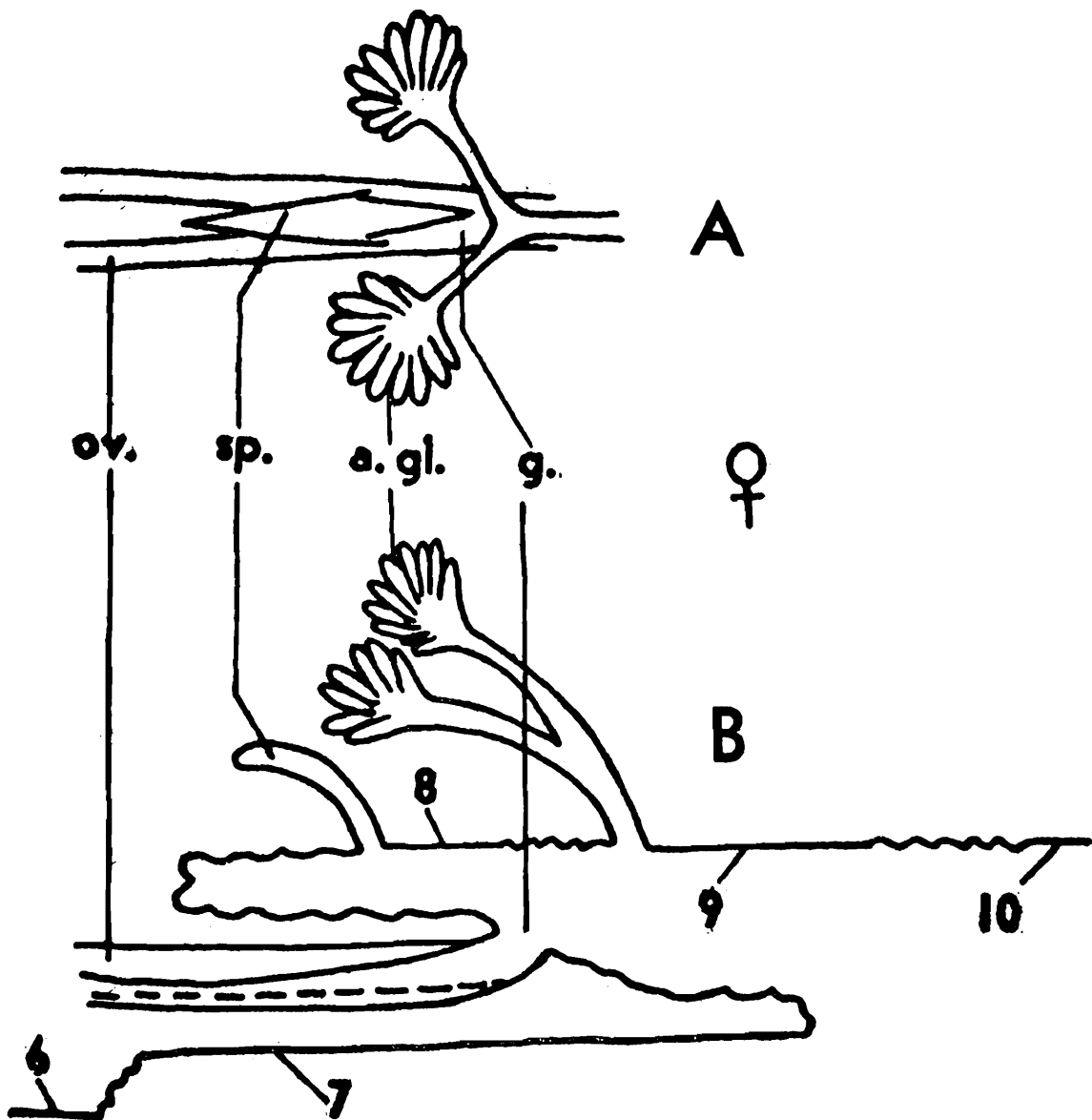

Fig. 30. Scheme of relationships of the sex apparatus in alate reproductive female at the posterior abdominal end in Isoptera. (A) In dorsal view. (B) In longitudinal-vertical section. (Ex Heberdey, 1931.)

6-10, 6th to 10th sterna; a.gl., accessory gland; ft., fontanelle; g., gonopore (opening of common oviduct); ov., lateral oviduct; sp., spermatheca.

There are either two or three female accessory glands which open through a common aperture on sternum 9; the third gland is sometimes atrophied. (Claims that the glands open directly into the common oviduct are incorrect.) In some cases (*Procryptotermes hubbardi*) a minute gland opens into the intersternal fold between sterna 7 and 8 directly ventral to (i.e. posterior to) the gonopore. Thus, four median external openings may occur in the female genital region, one rare and three common. These lie, from front to back, in the order stated below: (i) Opening of the minute gland (rare); (ii) the gonopore; (iii) the opening of the spermatheca; and (iv) the opening of the accessory glands.

6. *Chaetotaxy*  
(Figs. 31-34)

Chaetotaxy is the study of the arrangement of setae, both long and short, on the body parts. Unlike the Diptera and the larvae of Lepidoptera and Coleoptera, no extended study of chaetotaxy has been made in the Isoptera as a whole, although the setal arrangement on the abdomen has occasionally (*Coptotermes*) been used to separate species.

Kushwaha (1959, 1960c, d, 1962a, b) has studied chaetotaxy in various castes of three species of *Odontotermes* and found some specific differences. For instance, in soldiers the number of labral setae, which are generally

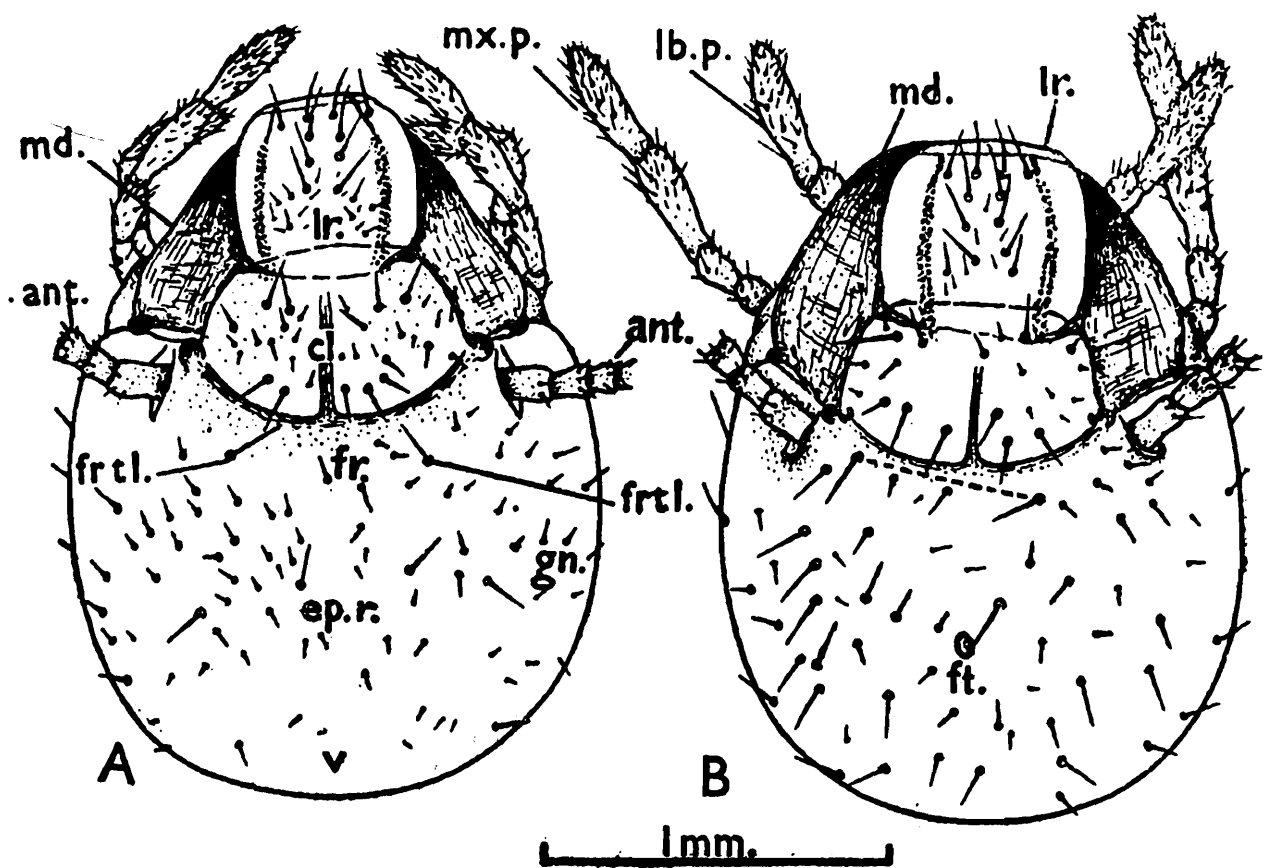

Fig. 31. *Odontotermes obesus*, worker. Chaetotaxy of head dorsum. (A) Apart from the smaller setae, only a few of the larger ones (bristles) are shown. (B) Showing the bristles. (Ex Kushwaha 1962 b.)

ant., antenna; ep.r., epicranial region; fr., frons; frtl., frontal bristle; ft., fontanelle; gn., gena; lb.p., labial palp; lr., labrum, md., mandible.

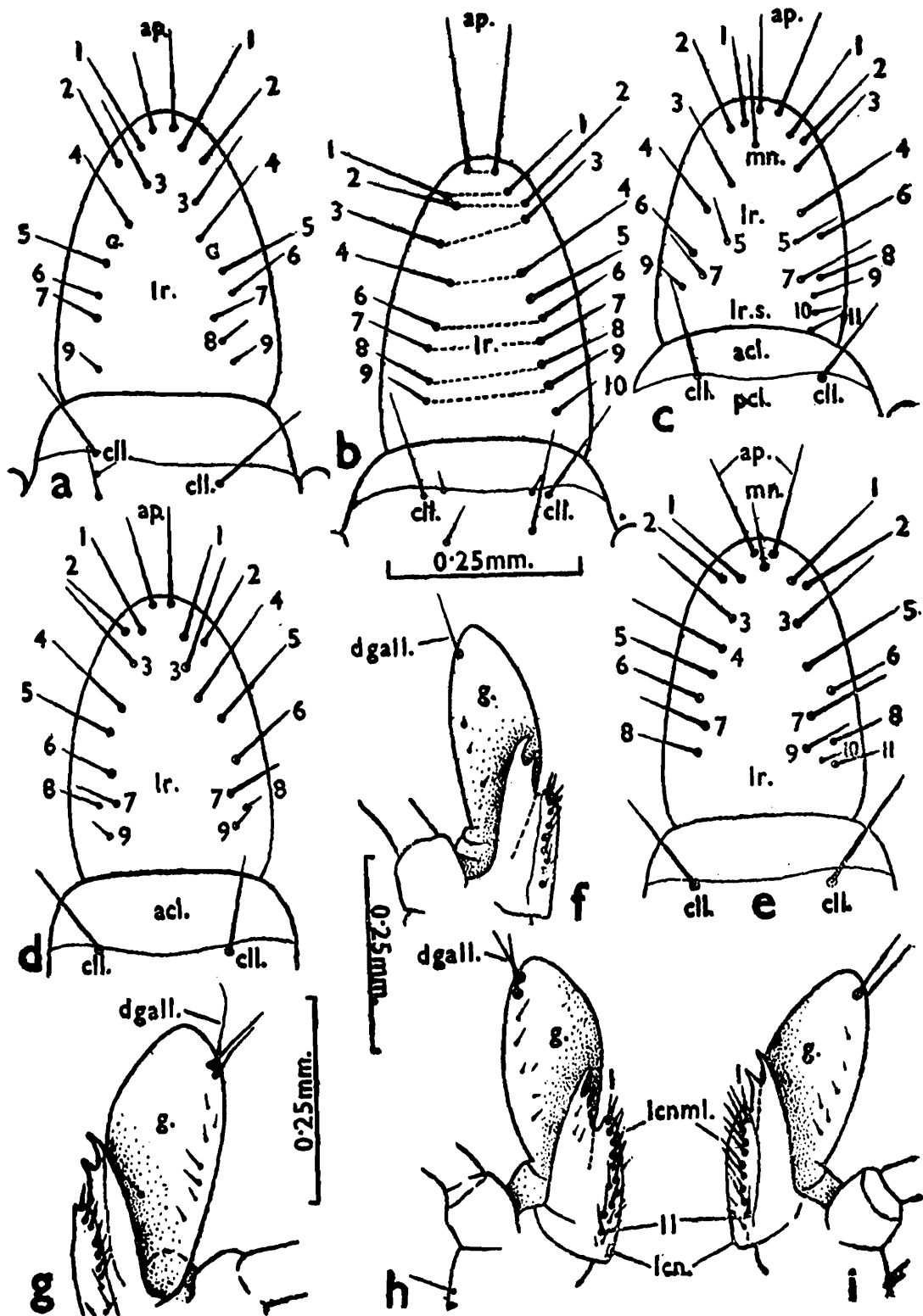

Fig. 32. *Odonotermes obesus*, soldier. Chaetotaxy of labrum (Figs. a-e) and lacinia-galea of maxilla (figs. f-i). Symmetrical bristles are joined by dotted lines in Fig. b. (Ex Kushwaha, 1962 b.)

1-11, bristles; acl., anteclypeus; ap., apical bristles of labrum; cll., clypeal bristle; dgall., disto-galeal bristle; g., galea; lcn., lacinia; lcnml., lacinal bristles; lr., labrum; lr.s., labral suture; mn., median bristle.

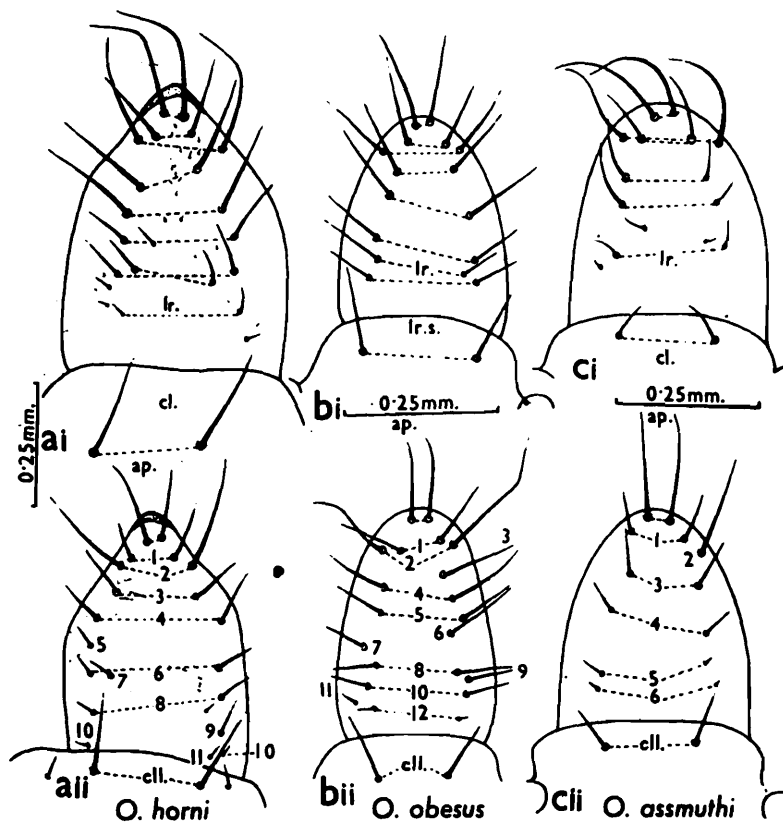

Fig. 33. Chaetotaxy of labral and clypeal bristles (dorsal views) in soldiers of three species of *Odontotermes* (*horni*, *obesus* and *assmuthi*) (Ex Kushwaha 1962a). Bilaterally symmetrical bristles joined by dotted lines.  
 ap., apical bristles; cl., clypeus; cll., clypeal bristles; lr., labrum; lr.s., labral suture; 1-12, lateral bristles of labrum.

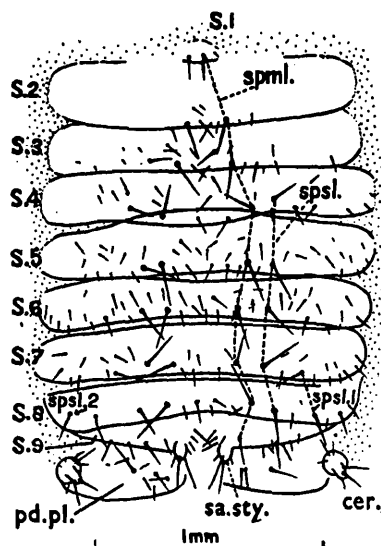

Fig. 34. *Odontotermes obesus*, worker. Abdominal sterna, to show chaetotaxy. (Ex Kushwaha, 1962 b.)  
 cer., cercus; pd.pl. padical plate; S.1-S.9, 1st to 9th sternite; sa. sty., subanal style; spml., line joining medial symmetrical setae; spsl., lines joining lateral symmetrical setae.

bilaterally symmetrical, is 10-12 pairs in *O. horni*, 8-12 pairs in *O. obesus* and 6-7 pairs in *O. assmuthi*. There seems to be no marked sexual dimorphism in setal arrangement. A few body parts are illustrated here (Fig. 31-34) to show setal arrangement, but only an extended study will show whether chaetotaxy can be used as a character for the differentiation of taxa in other termites.

### 7. Termite Measurements and Indices

(Figs. 35-49)

#### (i) General :

The relative size and proportion of the various body parts provide important characters for taxonomic differentiation between species and subspecies, and sometimes even genera. Accurate and well defined measurements are, therefore, of the utmost importance. Not only the parameters of the parts concerned but also the method of measurement should be accurately defined.

The early taxonomists used a few measurements, especially the total body size, the head, etc., but failed to define the measurement points. As a consequence, a comparison of their data with fresh measurements becomes difficult. Light (1921-1946) was the first termitologist to fully appreciate the importance of accurate measurements, and in a series of papers he not only defined a large number of measurements but also illustrated his definitions with clear figures. Subsequent workers more or less followed in his footsteps, and also added new measurements. Roonwal (1964, 1970b) has reviewed the entire subject and provided illustrated definitions of 88 measurements and 53 indices, and the following account is based largely on his 1970b monograph.

The body parts found most important for taxonomic differentiation are the head and pronotum, though other parts, e.g., abdomen, legs, wings, etc. are occasionally useful. In taking and studying measurements the following general principles should be adhered to :

(i) The fully formed individual of each caste (alate, soldier, worker or pseudoworker) is measured as a rule.

(ii) Measurements are generally taken in alcohol-preserved specimens, with the concerned body-parts *in situ* and not dissected out and flattened on a slide. (Dry or pinned specimens may be used where necessary, but this fact

should be mentioned in the record. Similarly, if the body-parts, e.g., labrum, postmentum, etc., are mounted flat on a slide, this fact should be stated.)

(iii) Hairs, bristles, etc., present on a body part are, as a rule, excluded from measurement.

(iv) Measurements of body parts should be taken under a stereobinocular microscope at a magnification of about  $20\times$  to  $50\times$ , and with the aid of an ocular micrometer. The larger measurements, e.g., body-length, wing-length, etc., which are approximate, may be taken with a vernier calliper preferably having a dial graduation.

(v) While measuring, the body part should be kept as flat as possible.

(vi) All measurements should be recorded in millimetres.

(vii) Except when otherwise stated, all measurements are straight-line distances between two points, and *not* along the curvatures of the body parts. In most cases it is convenient to define these distances as the shortest or vertical distance between two parallels which pass through the outer limits of the parts to be measured.

(viii) In the case of paired, bilaterally symmetrical organs, e.g., eyes, ocelli, mandibles, antennae, wings, legs, cerci, etc., the left organ should, for the sake of uniformity, be measured, except in the case of wings where it is more convenient to measure the structures of the right side. If the body-part of the proper side is injured, or for some other reason the opposite part is utilized, this fact should be mentioned. In some cases where the two members of a paired body part are bilaterally asymmetrical (e.g., the mandibles of *Capritermes*-group soldiers), the right and left members should be measured separately and so recorded.

(ix) Where a body part, e.g., the maximum head length, can be measured in more than one way, differing with the points selected, the different measurements are separated by the suffix A, B, C, etc.

(x) When large samples are available, simple statistical constants (such as Mean and Standard Deviation) may be used besides the range for comparison. Elaborate statistical treatments are as a rule unnecessary and defeat the purpose of practicability and speed.

Of the numerous measurements and indices which have been used by various authorities, the following 35 measurements and 20 indices are the

more important ones and are defined below: The castes for which they are suitable is indicated in each case, e.g., **Im**, imago; **S**, soldier; and **W**, worker or pseudoworker. Where special individuals, e.g., physogastric queens, are measured, this fact should be stated for their body-length would vary with the degree of [physogastry and absolute comparison will not be possible. (For a detailed account and for several other measurements Roonwal's monograph, 1970b should be consulted.)

(ii) *The more important measurements :*

1. Total body-length without wings. (Im, S, W)
2. Total body-length with wings. (Im)
3. Length of head to lateral base of mandibles. (Im, S, W)
4. Length of head to cephalic ridge A. (S)
5. Length of head to cephalic ridge B. (S)
6. Length of head with rostrum. (S)
7. Length of head-rostrum. (S)
8. Length of head without rostrum. (S)
9. Posterior bulge of head. (S)
10. Width of head-rostrum at base. (S)
11. Maximum width of head with eyes. (Im, S, W)
12. Height of head excluding postmentum. (Im, S, W).
13. Occipito-fontanelle distance. (Im, S, W)
14. Maximum diameter of fontanelle rim. (Im, S, W)
15. Maximum length of labrum. (Im, S, W)
16. Maximum width of labrum. (Im, S, W)
17. Maximum length of mandible. (S) for all mandibular measurements the left and right mandibles should be measured separately.
18. Tooth distance from distal tip of mandible. (S)
19. Maximum diameter of compound eye with ocular sclerite. (Im, S, W)
20. Minimum diameter of compound eye with ocular sclerite. (Im, S, W)
21. Maximum diameter of lateral ocellus. (Im, S, W)
22. Minimum diameter of lateral ocellus. (Im, S, W)
23. Minimum eye-ocellus distance. (Im, S, W)
24. Maximum length of postmentum. (S)
25. Minimum (median) length of postmentum. (S)

26. Maximum width of postmentum. (S)
27. Minimum width of postmentum. (S)
28. Maximum length of pronotum. (Im, S, W)
29. Maximum width of pronotum. (Im, S, W)
30. Maximum length of forewing with scale. (Im)
31. Minimum length of forewing without scale. (Im)
32. Maximum length of forewing scale. (Im)
33. Maximum length of hindwing with scale. (Im)
34. Minimum length of hindwing without scale. (Im)
35. Maximum length of hindwing scale. (Im)

(iii) *The more important indices :*

1. Head Index A (Width-Length Index-1). (Im, S, W)
2. Head Index B (Width-Length Index-2). (Im, S, W)
3. Head Index C (Width-Length Index-3). (S)
4. Head Index D (Height-Length Index-1). (Im, S, W)
5. Head Index E (Height-Length Index-2). (S)
6. Head Index F (Height-Width Index). (S)
7. Head Contraction Index (Width Index). (S)
8. Rostrum-Head Index (Length). (S)
9. Fontanelle Distance Index. (Im, S, W)
10. Fontanelle Rim Index. (Im, S, W)
11. Labrum Index A (Width-Length Index-1). (Im, S, W)
12. Labrum Index B (Width-Length Index-2). (Im, S, W)
13. Mandible-Head Index (Length-Length Index). (S)
14. Eye Index. (Im, S, W)
15. Lateral Ocellus Index. (Im, S, W)
16. Eye-Ocellus Distance Index A. (Im, S, W)
17. Eye-Ocellus Distance Index B. (Im, S, W)
18. Postmentum Index A (Width-Length Index). (S)
19. Postmentum Index B (Width Contraction Index). (S)
20. Pronotum-Head Index (Width-Width Index). (Im, S, W).

(iv) *Definitions of the more important measurements :*

1. *Total body-length without wings* (Figs. 35 and 36, line AA') Distance between two parallels marking the foremost tip of the head-capsule (excluding the bristles, antennae and palpi but including the mandibles) and the hindmost tip of the abdomen (excluding the styli, cerci and bristles). Measured dorsally. Suitable for all castes.

*Note* In soldiers the foremost point is usually the anterior tip of either the mandibles or the head-rostrum (in the nasutiform species), or in a few cases, the labrum; and in workers and imagoes generally the tip of the

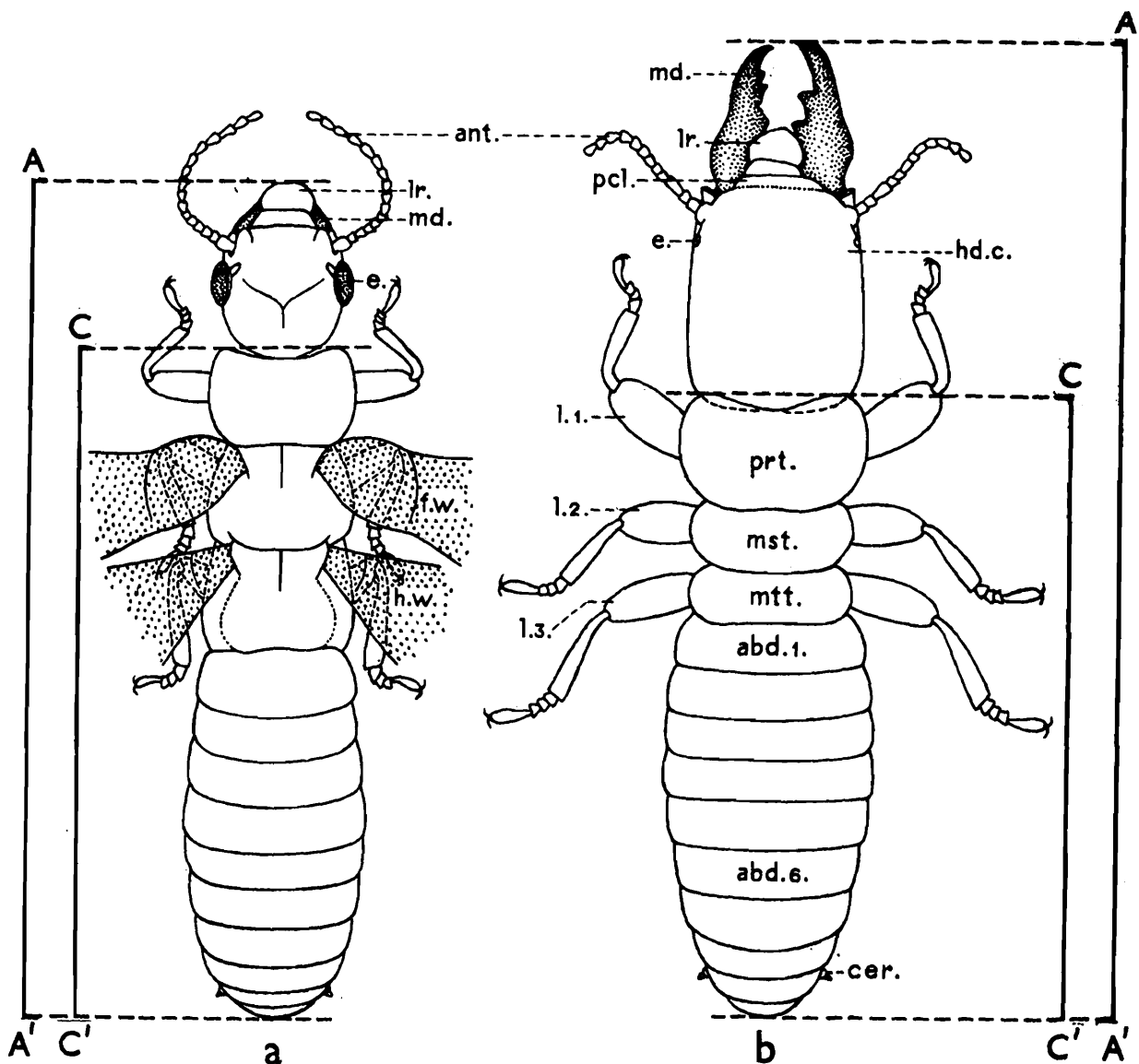

Fig. 35. Dorsal view of *Bifiditermes beelsoni* (Gardner). (a) Imago (alate); only basal part of wings shown. (b) Soldier. To show the following measurements: (i) Total body-length without wings (line AA'). (ii) Body-length without head (line CC'). (Ex Roonwal 1970 b.)

abd. 1, abd. 6. first and sixth abdominal segments; ant., antenna, cer., cercus; e., eye; f.w., forewing; h.w., hindwing; l.1, l.2, l.3, first, second and third legs; lr., labrum; md. mandible; mst., mesonotum; mtt., metanotum; prt., pronotum.

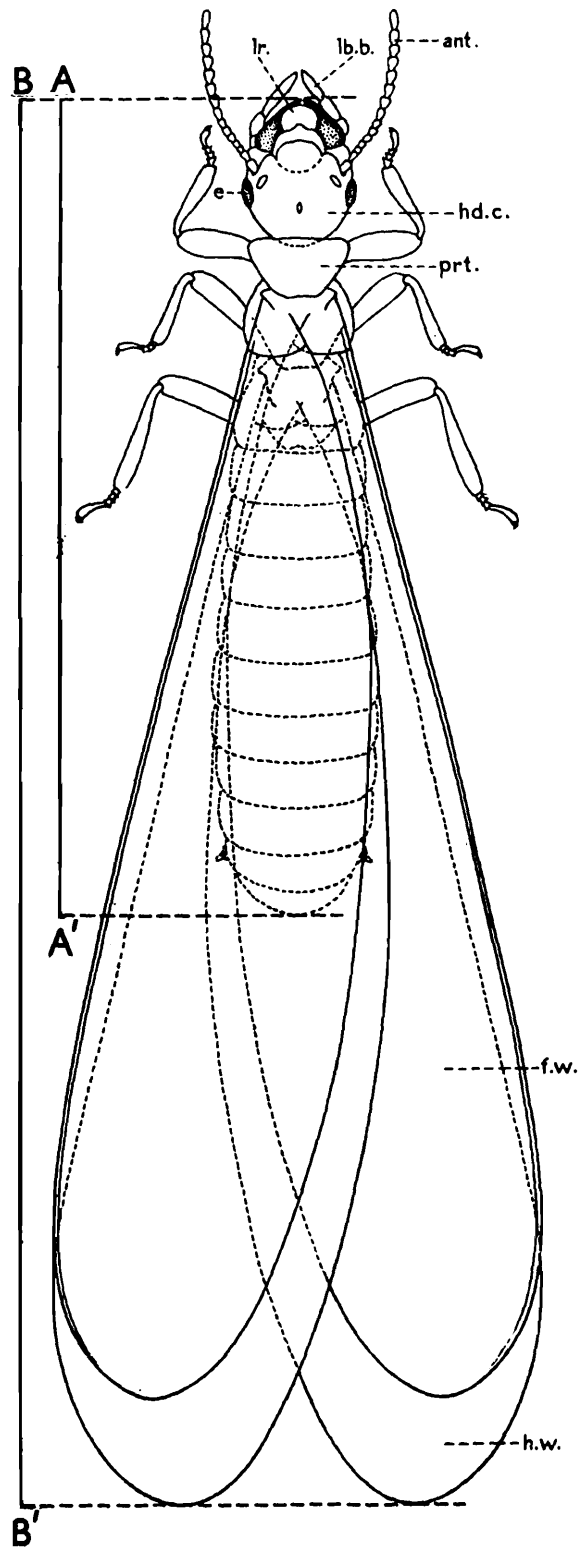

Fig. 36. Alate imago of *Eremotermes paradoxalis* Holmgren, in dorsal view. To show the following measurements: (i) Total body-length without wings (line AA'). (ii) Total body-length with wings (line BB'). (Ex Roonwal, 1970 b.)  
 ant., antenna; e., eye; f.w., forewing; hd.c., head-capsule; h.w., hindwing; lb.p., labial palp; lr., labrum; prt., pronotum.

labrum. As this measurement depends greatly on the position of the head, which is often determined by the method of preservation, it should be used with caution. Its utility consists not so much in providing an exact measure of size but rather a rough indication of it. Normally for this measurement, the head and the rest of the body should be in one line.

2. *Total body-length with wings* (Fig 36, line BB'). Distance between two parallels marking the foremost tip of the head-capsule (excluding the bristles, antennae and palpi but including the mandibles) and the hindmost tip of the wings when folded over the abdomen. Measured dorsally. Suitable for winged imagoes.

3. *Length of head to lateral base of mandibles* (Fig . 37, Line EE'). Distance between two parallels marking the hindmost margin of the head-

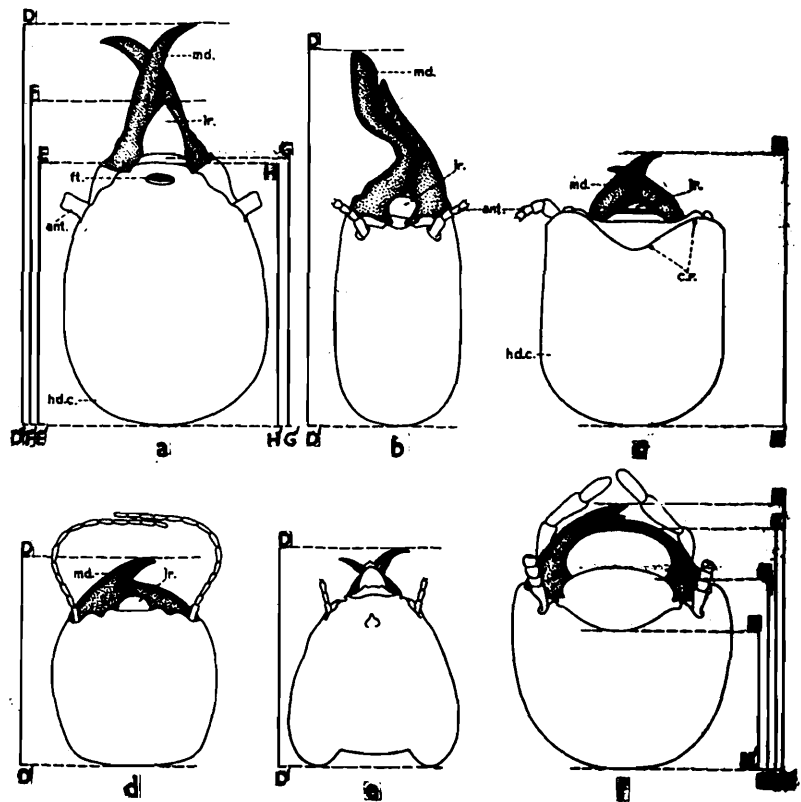

Fig. 37. Head capsules, in dorsal view of: (a) *Coptotermes formosanus* Shiraki; soldier. (b) *Pericapritermes latignathus durga* Roonwal and Chhotani; soldier. (c) *Cryptotermes* sp.; soldier. (d) *Indotermes maymensis* Roonwal and Sen-Sarma; soldier. (e) *Acanthotermes acanthothorax* (Sjöstedt); soldier major. (f) *Amitermes arizonensis* Banks; worker. To show the following measurements: (i) Length of head including mandibles (line DD'). (ii) Length of head to lateral base of mandibles (line EE'). (iii) Length of head to tip of labrum (line FF'). (iv) Length of head to median base of labrum (line GG'). (v) Length of head to median base of clypeus (line HH'). (Ex Roonwal 1970 b.) c.r., cephalic ridge. Rest of lettering as in previous figure.

capsule and the external articulations of the mandible. Measured dorsally. Suitable for all castes.

4. *Length of head to cephalic ridge (A)* (Fig. 38, line  $KK'$ ). Distance between two parallels marking the hindmost margin of the head-capsule and the most distal margin of the cephalic ridge (frontal flange of authors). Measured dorsally. Suitable for soldiers of certain genera, e.g., *Cryptotermes*, *Eremotermes*, etc.

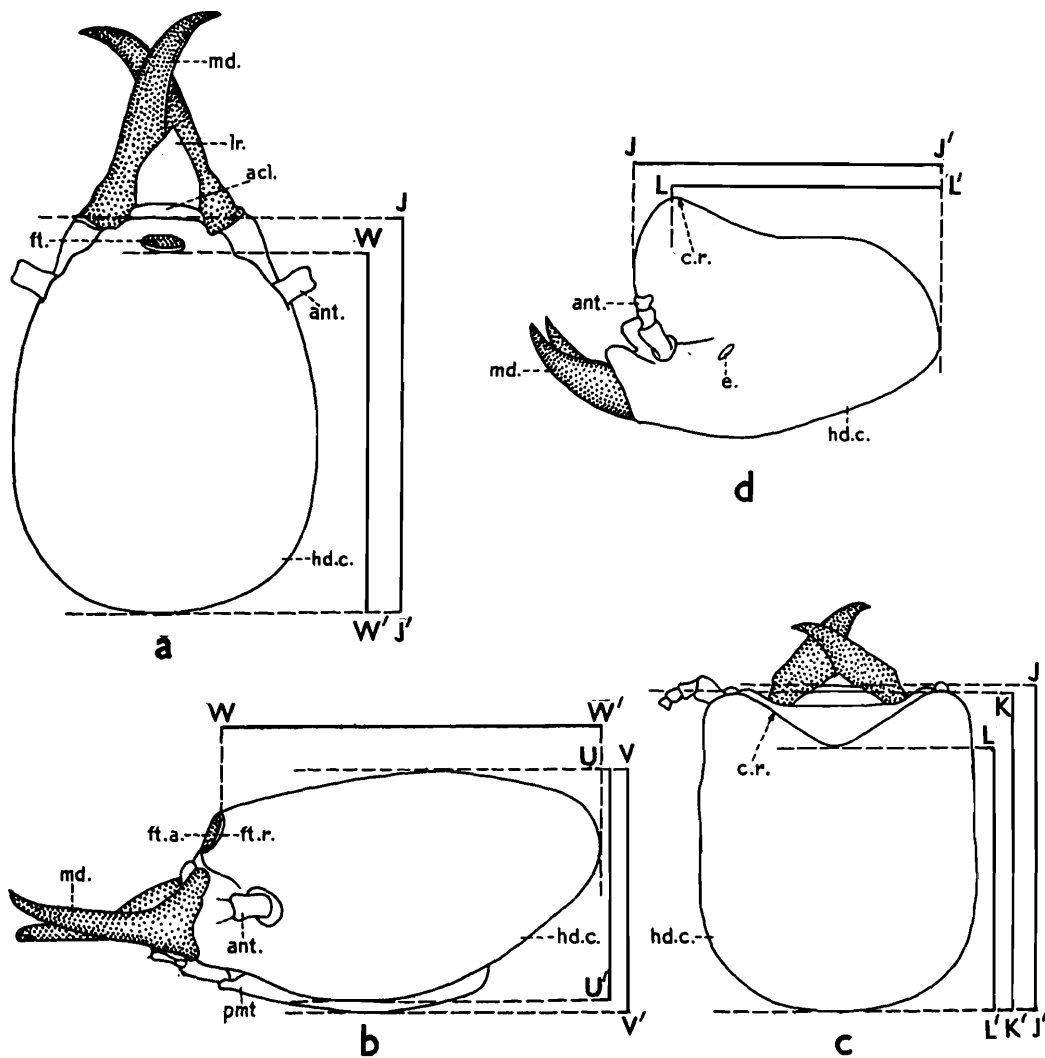

Fig. 38. Heads of soldiers of: (a) *Coptotermes formosanus* (Shiraki), in dorsal view. (b) Ditto, in side view. (c) *Cryptotermes* sp., in dorsal view. (d) Ditto, in side view. To show the following measurements : (i) Length of head-capsules (line  $JJ'$ ). (ii) Length of head to cephalic ridge (I) (Line  $KK'$ ). (iii) Length of head to cephalic ridge (II) (Line  $LL'$ ). (iv) Height of head excluding postmentum (line  $UU'$ ). (v) Height of head including postmentum) Line  $VV'$ ). (vi) Occipito-fontanelle distance (Line  $WW'$ ). (Ex Roonwal, 1970 b.)

acl., anteclypeus; c.r., cranial ridge; ft., fontanelle; ft.a., fontanelle . aperture; ft.r., fontanelle rim. Rest as in Fig. 37.

*Note* : The extension of the cephalic ridge varies greatly in species of *Cryptotermes*, from those in which the median part of the ridge lies relatively far back to those in which it lies far forward, in the later case covering a large part of the mandibles. Hence an alternative measurement, along the mid-longitudinal line, is necessary, vide infra, No. 5.

5. *Length of head to cephalic ridge* (B) (Fig. 38, line LL'). Distance between two parallels marking the hindmost margin of the head-capsule and the most distal margin of the cephalic ridge in the median longitudinal line. Measured dorsally. Suitable for soldiers of certain genera, e.g., *Cryptotermes*, *Eremotermes*, etc. (cf. No. 4, supra.)

6. *Length of head with rostrum* : (Fig. 39, line MM'). Distance between two parallels marking the hindmost margin of the head-capsule and the

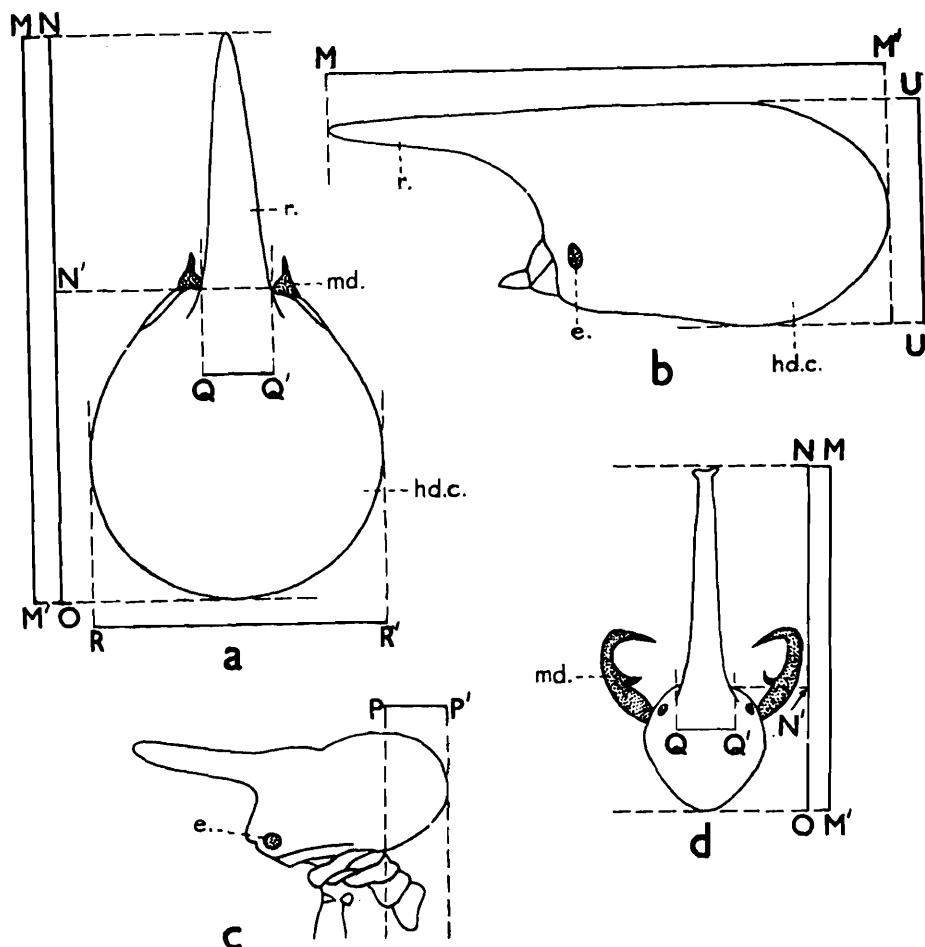

Fig. 39. Head of soldiers of : (a) *Nasutitermes taylora* Light and Wilson, in dorsal view. (b) Ditto, in side view. (c) *Diversitermes melanocephalus* (Snyder), soldier minor, in side view. (d) *Rhynchotermes perarmatus* (Snyder), soldier, in dorsal view. To show the following measurements; (i) Length of head with rostrum (line MM'). (ii) Length of head-rostrum (line NN'). (iii) Length of head without rostrum (line NO'). (iv) Posterior bulge of head (line PP'). (v) Width of head rostrum at base (line QQ'). (Ex Roonwal, 1970 b.)

e. eye; hd.c., head-capsule; md., mandible; r., rostrum.

foremost tip of the rostrum. Measured laterally. Suitable for soldiers with a nasutiform head, as in the Nasutitermitinae.

7. *Length of head-rostrum* (Fig. 39, line NN'). Distance between two parallels marking the innermost point of the front of the head-capsule below the base of the rostrum and the tip of the rostrum. Measured laterally. Suitable for soldiers with a nasutiform head.

8. *Length of head without rostrum* (Fig. 39, line N'O). This is of course the difference between the values of the 'length of head with rostrum' and the 'length of head-rostrum' Suitable for soldiers with a nasutiform head.

9. *Posterior bulge of head* (Fig. 39, line PP'). Distance between two parallels marking the hindmost margin of the head-capsule and the hind margin of the articulation of the neck (cervix) with the head-capsule. Measured laterally. Suitable for soldiers, especially the nasutiform ones.

*Note* : It corresponds to the 'head production' of authors and indicates the degree of the posterior extension or bulge of the head-capsule.

10. *Width of head-rostrum at base* (Fig. 39, line QQ'). Distance between two parallels marking the maximum width of head-rostrum at its base (junction with the head-capsule). Measured dorsally. Suitable for soldiers with a nasutiform head.

*Note* : Since the junction of the rostrum with the head-capsule is gently curved, this measurement can not be very exact. Nevertheless, it is useful to indicate the thickness and shape of the rostrum and for calculating the index Width/Length of rostrum.

11. *Maximum width of head with eyes* (Figs. 39a and 40, line RR'). Distance between two parallels marking the outermost lateral margins of the head-capsule (including the compound eyes when present, otherwise without them). Suitable for all castes.

12. *Height of head excluding postmentum* (Figs. 38 and 39, line UU'). Distance between two parallels marking the most dorsal and the most ventral surfaces of the main head-capsule, excluding the rostrum (when present) and the postmentum. Measured laterally. Suitable for all castes.

13. *Occipito-fontanelle distance* (Fig. 38, line WW'). Distance between two parallels marking the hindmost margin of the head-capsule and the

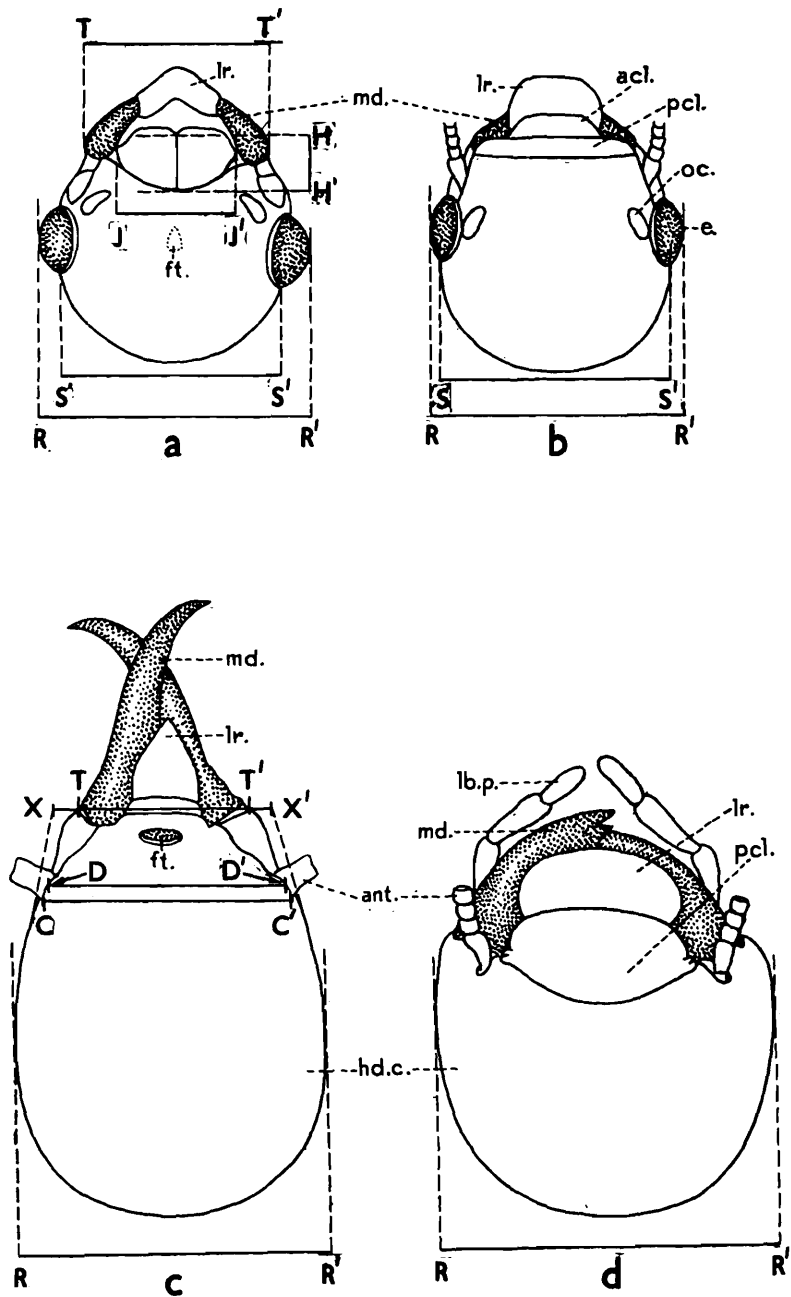

Fig. 40. Heads in dorsal view of: (a) *Amitermes foreli* Wasmann (syn. *A. medius* Banks); alate imago. (b) *Neotermes artocarpi* (Haviland); imago. (c) *Coptotermes formosanus* (Shiraki); soldier. (d) *Amitermes arizonensis* Banks; worker. To show the following measurements: (i) Maximum width of head with eyes (when present) (line RR'). (ii) Width of head without eyes (when eyes present) (line SS'). (iii) Minimum width of head (I) (line XX'). (v) Antennal faveolar distance (I) (line CC'). (vi) Antennal faveolar distance (II) (line DD'). (vii) Median length of postclypeus (line HH'). (viii) Width of postclypeus (line JJ'). (Ex Roonwal, 1970 b.)

acl., anteclypeus; ant., antenna; e., eye; ft., fontanelle; lb.p., labial palps; lr., labrum; hd.c., head-capsule; oc., ocelli; pcl., postclypeus.

posterior margin of the fontanelle rim. measured middorsally. Suitable for all castes possessing the fontanelle.

An alternative measurement, to the 'posterior margin of the fontanelle aperture', is also possible, but offers no particular advantage.

14. *Maximum diameter of fontanelle rim* (Fig. 41, line XX ). Distance between two parallels marking the *outer* edges of the fontanelle rim (not the aperture) along its longest diameter. Measured dorsally, with the fontanelle held horizontal. Suitable for all castes possessing the fontanelle.

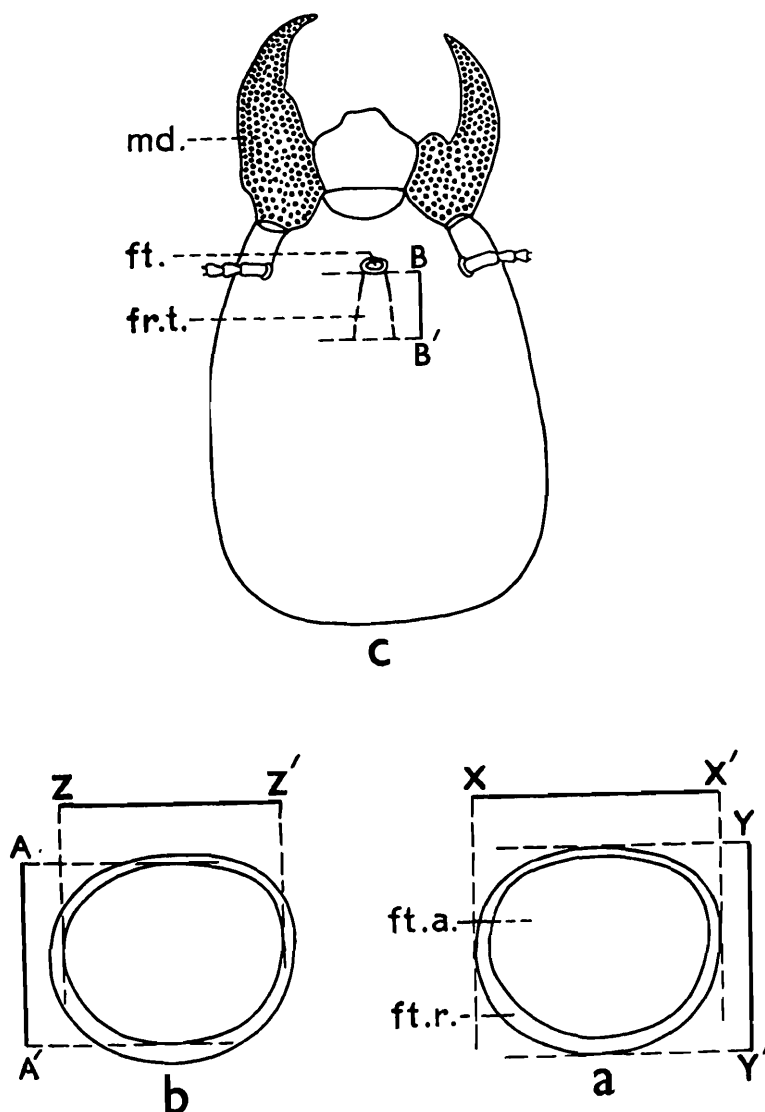

Fig. 41. (a), (b) Fontanelle of *Coptotermes* sp., in dorsal view. (c) Head of soldier of *Cornitermes* sp., in dorsal view. To show the following measurements: (i) Maximum diameter of fontanelle rim (line XX'). (ii) Minimum diameter of fontanelle rim (line YY'). (iii) Maximum diameter of fontanelle aperture (line ZZ'). (iv) Minimum diameter of fontanelle aperture (line AA'). (v) Length of frontal tube (line BB'). (Ex Roonwal 1970 b.)

fr.t., frontal tubes; ft., fontanelle; ft.a., fontanelle aperture; ft.r., fontanelle rim; md., mandible.

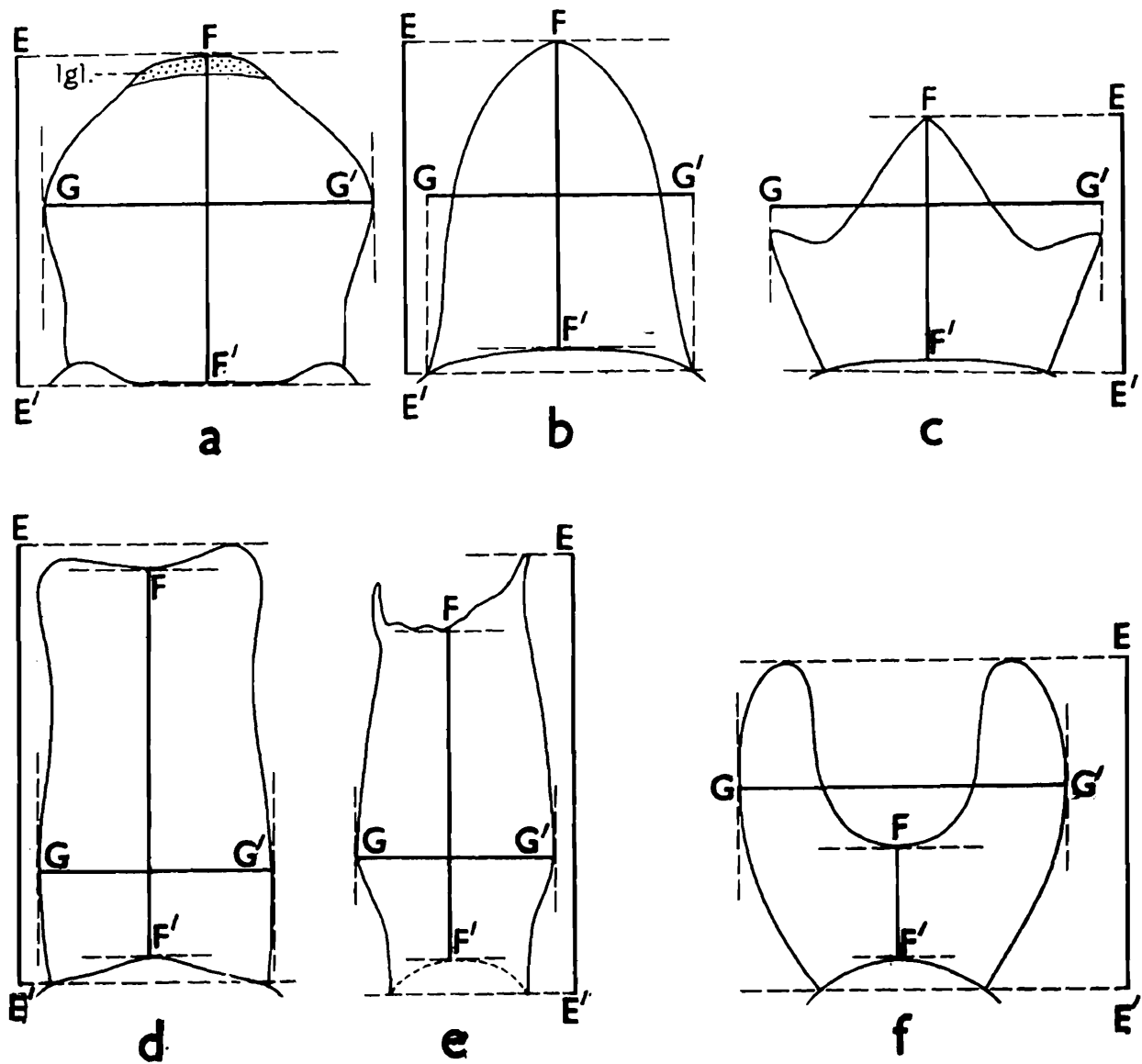

Fig. 42. Labrum, in dorsal view, of soldiers of: (a) *Indotermes rongrensis* (Roonwal and Chhotani); worker. (b) *Odontotermes giriensis* Roonwal and Chhotani; soldier. (c) *Procornitermes triacifer* (Silvestri); soldier. (d) *Schedorhinotermes tiwarii* Roonwal and Thakur; soldier minor. (e) *Pseudocapritermes tikadari* Roonwal and Chhotani; soldier. (f) *Furculitermes brevimaculatus* Emerson. To show the following measurements: (i) Maximum length of labrum (Line  $EE'$ ). (ii) Median length of labrum (line  $FF'$ ). (iii) Maximum width of labrum (line  $GG'$ ). (Ex Roonwal, 1970 b.)  
lgl., lingula (hyaline tip of labrum).

15. *Maximum length of labrum* (Fig. 42, line  $EE'$ ). Distance between two parallels marking the most distal and the most proximal margins of the labrum. (This may or may not be along the median-longitudinal line, vide infra.). Measured dorsally, with the labrum held flat *in situ*. Suitable for all castes.

*Note* : If the measurement is from a dissected labrum mounted flat on a slide, this fact should be mentioned.

16. *Maximum width of labrum* (Fig. 42, line GG'). Distance between two parallels marking the outermost lateral margins of the labrum. Measured dorsally, with the labrum held flat *in situ*. Suitable for all castes.

17. *Maximum length of mandible* (Fig. 43, line LL'). Distance between two parallels marking the notch at the upper base of the outer mandibular

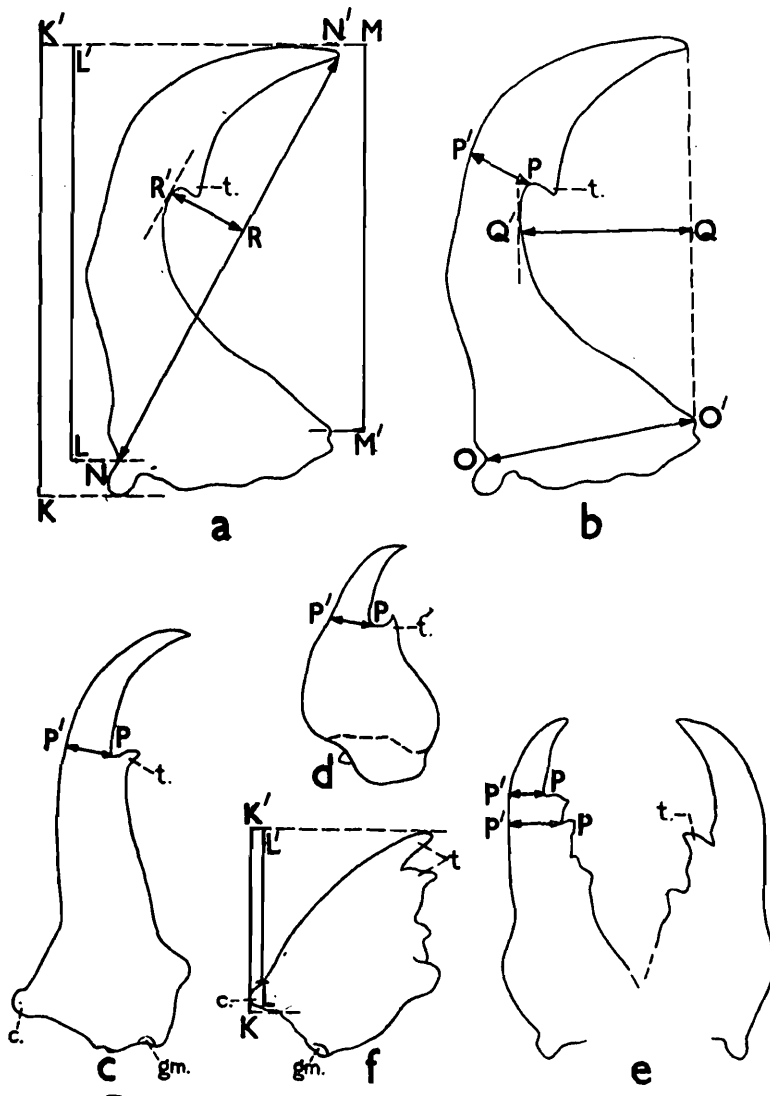

Fig. 43. Mandibles, in dorsal view, of: (a), (b) *Amitermes* sp., left mandibles of soldier. (c) *Odontotermes obesus* (Rambur); left mandible of soldier. (d) *Indotermes maymensis* Roonwal and Sen-Sarma; (e) *Bifiditermes pintai* (Kemner); left and right mandibles of soldier. (f) *Pericapritermes dunensis* (Roonwal and Sen-Sarma) left mandible of worker. To show the following measurements: (i) Maximum length of mandible (I) (line KK'). (ii) Maximum length of mandible (II) (line LL'). (iii) Inner length of mandible (line MM'). (iv) Cross length of mandible (line NN'). (v) Basal width of mandible (line OO'). (vi) Width of mandible in level of mandibular tooth (line PP'). (vii) Maximum mandibular curvature (line QQ'). (viii) Minimum mandibular curvature (line RR'). (Ex Roonwal 1970 b.)  
c., outer condyle; gm., ginglymus; t., tooth.

condyle and the most distal tip of the mandible. measured dorsally. Suitable for all castes, especially soldiers.

*Note* : The right and left mandibles should be measured separately even when they are symmetrical or nearly so, but for calculating indices the left mandible is generally used. When the mandibles are asymmetrical, separate measurements of both mandibles are of course essential.

18. *Tooth distance from distal tip of mandible* (Fig. 44, line ST). Distance between two parallels marking the distal point of origin of the main or

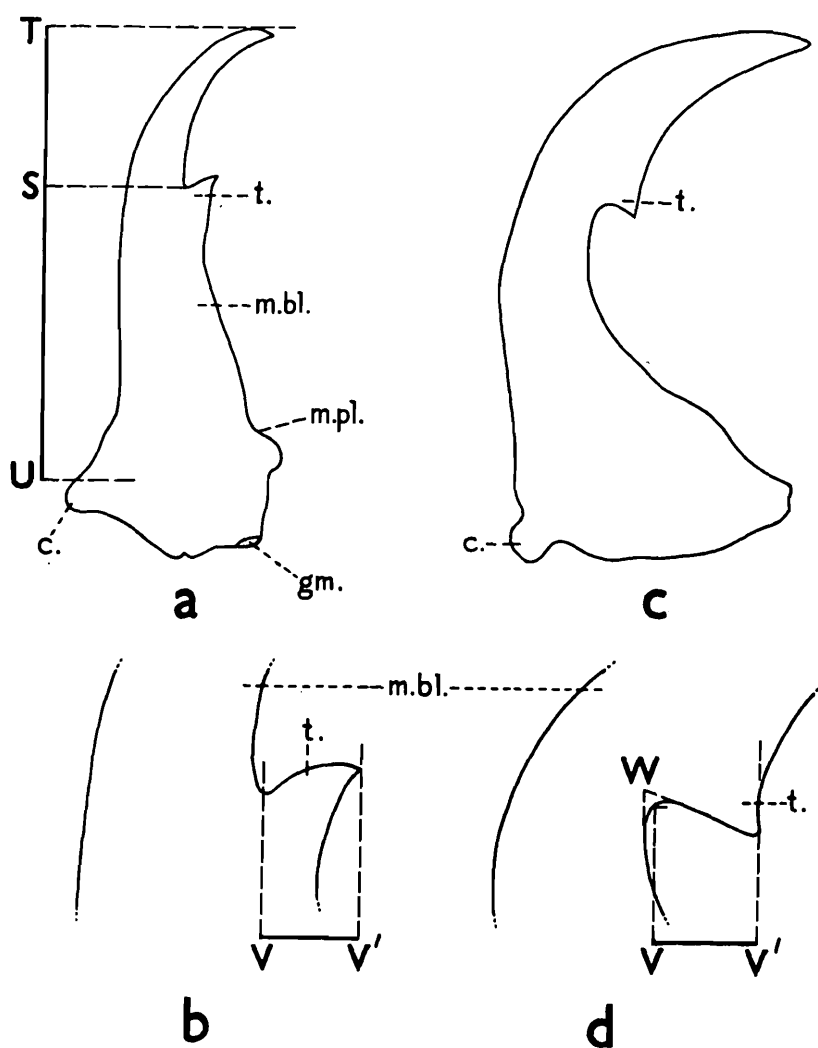

Fig. 44. Left mandibles of soldiers of: (a) *Odontotermes obesus* (Rambur). (b) Ditto, tooth region, (Origin of distal end of tooth from the mandibular blade is clear.) (c) *Amitermes* sp. (d) Ditto, tooth region. (Origin of proximal end of tooth from the mandibular blade is clear.) To show the following measurements: (i) Tooth distance from distal tip of mandible (line ST). (ii) Tooth distance from mandibular condyle (line SU). (iii) Length of mandibular tooth (line VV'). (iv) Angle of mandibular tooth (angle at point W in Fig. d.) (Ex Roonwal, 1970 b.)

c., outer condyle of mandible; gm., ginglymus; m.bl., mandibular blade; m.pl., molar plate of mandible; t., tooth.

largest tooth from the mandibular blade to the most distal tip of the mandible. Measured dorsally. Suitable for soldiers.

*Note* : In the soldiers of certain genera *Odontotermes*, etc.) the position of the largest tooth (when more than one are present) provides an important taxonomic character.

19. *Maximum diameter of compound eye with ocular sclerite* (Fig. 45, line AA'). Distance between two parallels marking the external margins of

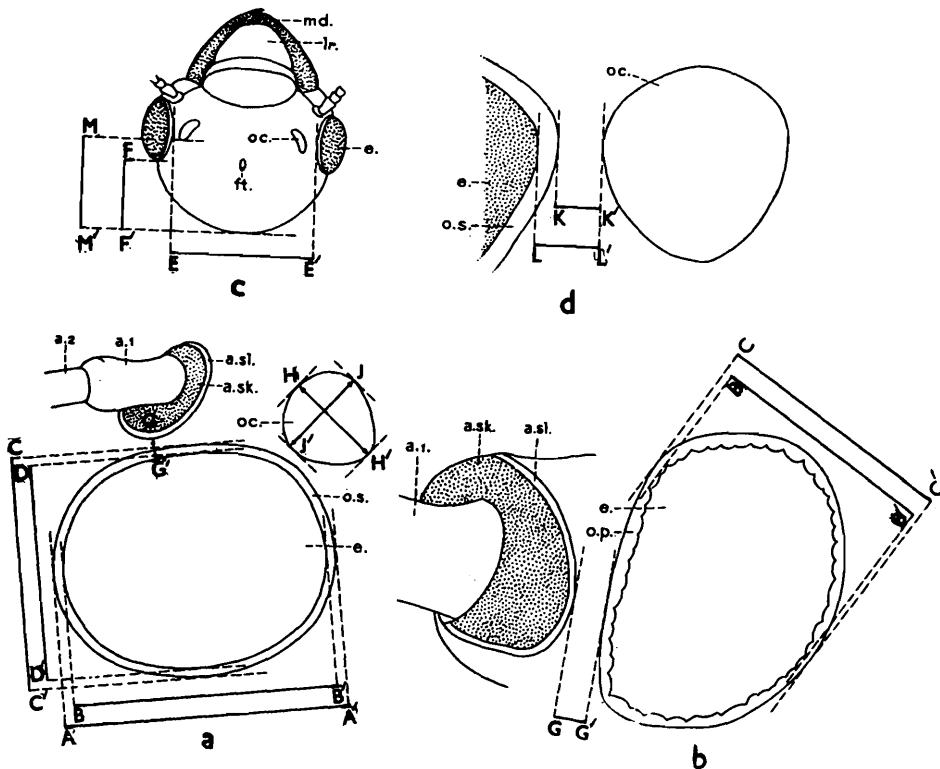

Fig. 45. Head, eyes, etc. of imagos of: (a) *Odontotermes obesus* (Rambur). Eye and ocellus region of head (left side), in the dorso-lateral view. (b) *Anacanthotermes macrocephalus* (Desneux). Eye region (left side) of head, in dorso-lateral view. (c) *Odontotermes microdentatus* Roonwal and Sen-Sarma, Head-capsule, in dorsal view. (d) *Odontotermes* sp. Eye and ocellus region (left side) of head, showing ocellus and part of compound eye. To show the following measurements: (i) Maximum diameter of compound eye with ocular sclerite (line AA'). (ii) Maximum diameter of compound eye excluding ocular sclerite (line BB'). (iii) Minimum diameter of compound eye with ocular sclerite (line CC'). (iv) Minimum diameter of compound eye excluding ocular sclerite (line DD'). (v) Inter-eye distance (line EE'). (vi) Occipito-eye distance (line FF'). (vii) Minimum eye-antennal distance (line GG'). (viii) Maximum diameter of lateral ocellus (line HH'). (ix) Minimum diameter of lateral ocellus (line JJ'). (x) Minimum eye-ocellus distance (I) (line KK'). (xi) Minimum eye-ocellus distance (II) (line LL'). (xii) Occipito-ocellar distance (line MM'). (Ex Roonwal 1970 b.)

a.l.a.2., first and second antennal segments; a.sk., antennal socket; a.sl., antennal sclerite; e., eye; ft., fontanelle; lr., labrum; md., mandible; oc., ocellus; o.s., ocular sclerite.

the compound eye, *including* the ocular sclerite, at the points of their widest separation. Measured with the head held in the position which provides the fullest view of the eye. Suitable for all castes where compound eyes are present.

20. *Minimum diameter of compound eye with ocular sclerite* (Fig. 45, line CC'). Distance between two parallels marking the external margins of the compound eye, including the ocular sclerite, at the points of their narrowest separation. Suitable for all castes where compound eyes are present.

21. *Maximum diameter of lateral ocellus* (Fig. 45, line HH'). Distance between two parallels marking the external margins of the lateral ocellus at the points of their widest separation. Suitable for all castes where lateral ocelli are present.

22. *Minimum diameter of lateral ocellus* (Fig. 45, line JJ'). Distance between two parallels marking the external margins of the lateral ocellus at the points of their narrowest separation. Suitable for all castes where lateral ocelli are present.

23. *Minimum eye-ocellus distance* (Fig. 45, line KK'). Distance between two parallels marking the outer margins of eye and of the lateral ocellus of its side at the points of their narrowest separation. Suitable for all castes where both compound eyes and ocelli are present.

24. *Maximum length of postmentum* (gula, gulamentum and submentum of authors) (Fig. 46, line NN'). Distance between two parallels marking the most distal (anterior) and the most proximal (posterior) margins of the postmentum. Measured ventrally, with the postmentum held horizontal *in situ*. Suitable for soldiers.

25. *Minimum (median) length of postmentum* (Fig. 46, line OO', not OP). Distance between two parallels marking the most distal (anterior) margin and the most proximal (posterior) *inner* margin (where clearly defined) of the postmentum in the median-longitudinal line. Measured ventrally, with the postmentum held horizontal *in situ*. Suitable for soldiers.

26. *Maximum width of postmentum* (Fig. 46, line QQ'). Distance between two parallels marking the lateral margins of the body of postmentum (not considering the anterior and posterior margins as a rule) in

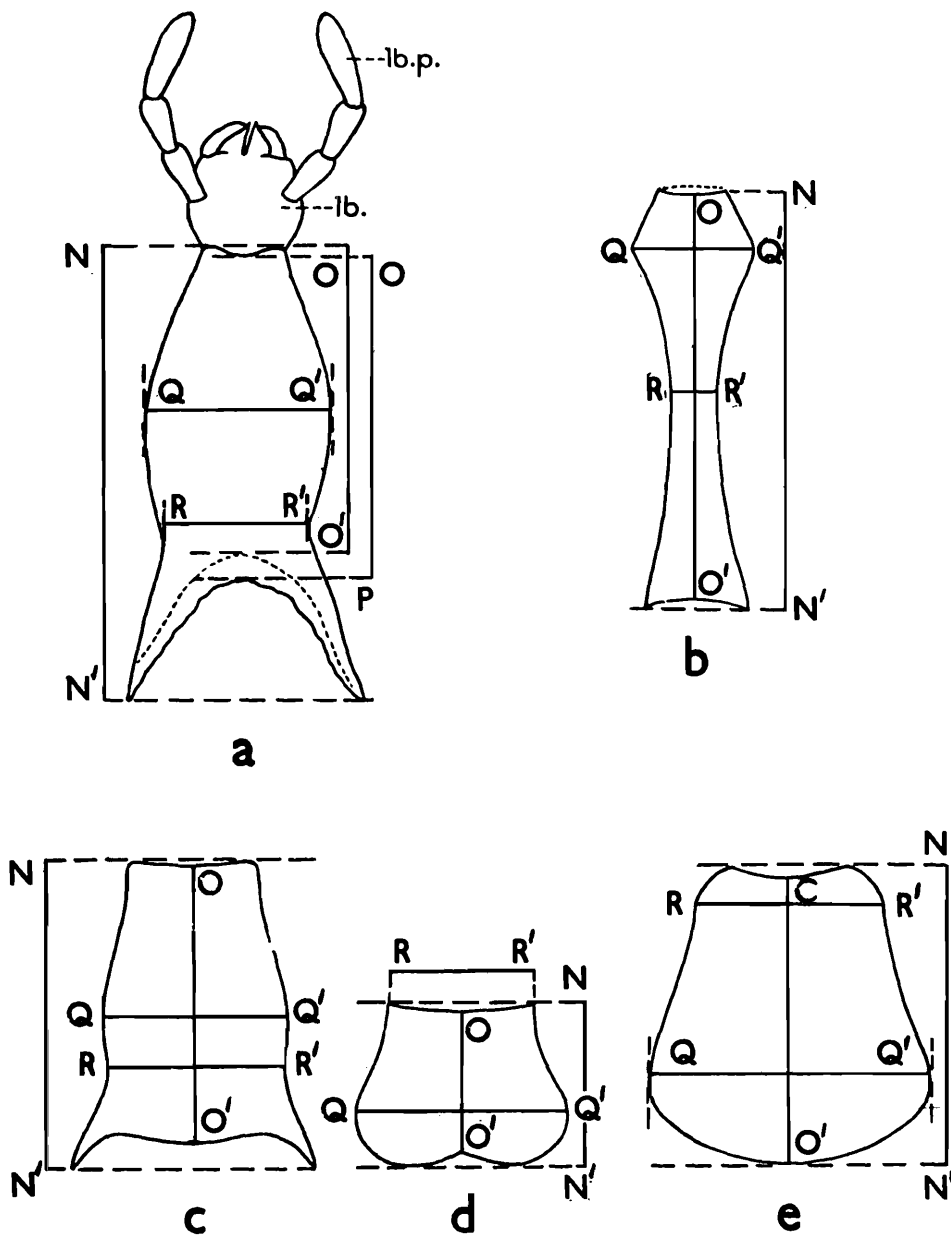

Fig. 46. Postmentum, in ventral view, of soldiers of: (a) *Amitermes snyderi* Light, with the labium attached at the distal end. (b) *Pericapritermes latignathus durga* (Roonwal and Chhotani). (c) *Cryptotermes dudleyi* Banks. (d) *Cryptotermes perforans* Kemner. (e) *Cryptotermes havilandi* (Sjöstedt.) To show the following measurements: (i) Maximum length of postmentum (line NN'). (ii) Minimum (median) length of postmentum (line OO', not OP). (iii) Maximum width of postmentum (line QQ'). (iv) Minimum width of postmentum (line RR'). (Ex Roonwal, 1970b.)  
lb., labium; lb.p., labial palp.

the level in which they are *most widely* separated. Measured ventrally, with the postmentum held horizontal *in situ*. Suitable for soldiers.

27. *Minimum width of postmentum* (Fig. 46, line RR'). Distance between two parallels marking the lateral margins of the postmentum in the

level in which they are *most narrowly* separated. Measured ventrally, with the postmentum held horizontal *in situ*. Suitable for soldiers.

*Note* : The 'minimum width' usually occurs in the proximal portion of the postmentum and forms the so-called 'waist' But there are exceptions (*Cryptotermes* spp., etc.), Another measurement, the 'width of postmentum at anterior margin' (which is generally much narrower than the width at the posterior margin) has been used in certain genera (*Coptotermes*, *Macrotermes*, *Odontotermes*).

28. *Maximum length of pronotum* (Fig. 47, line SS'). Distance between two parallels marking the foremost and the hindmost margins of the pronotum (including the spines when present but excluding the hairs and bristles) at the points of their *widest* separation. Measured dorsally, with the pronotum held horizontal *in situ*. Suitable for all castes.

*Note* : Since the pronotum is generally curved, frequently saddle-shaped, the value of this measurement *in situ* will be very different, and much smaller, than that obtained from a pronotum flattened and mounted on a slide. When, for a special reason, the latter method is followed, this should be mentioned. The spines are included because when present in certain termites (*Acanthotermes acanthothorax*, *Syntermes* spp., etc.) they form a part of the main body of the pronotum and cannot be separated; this does not apply to the hairs and bristles. In some species, the 'maximum length' may be the same as the 'median length'.

29. *Maximum width of pronotum* (Fig. 47, line UU'). Distance between two parallels marking the lateral margins of the pronotum (including the spines when present but excluding the hairs and bristles) in the level of their *widest* separation. Measured dorsally with the pronotum held horizontal *in situ*. Suitable for all castes.

30. *Maximum length of forewing with scale* (Fig. 48, line VV'). Distance between two parallels marking the most proximal margin of the articular sclerites of the forewing and the most distal margin of the wing-membrane. Measured with the wing fully stretched (at right angles to the body-length) and flattened. The right wing is more convenient to measure and is to be preferred. Suitable for winged imagoes.

31. *Minimum length of forewing without scale* (Fig. 48, line XX'). Distance between two parallels marking the most distal margin of the scale-

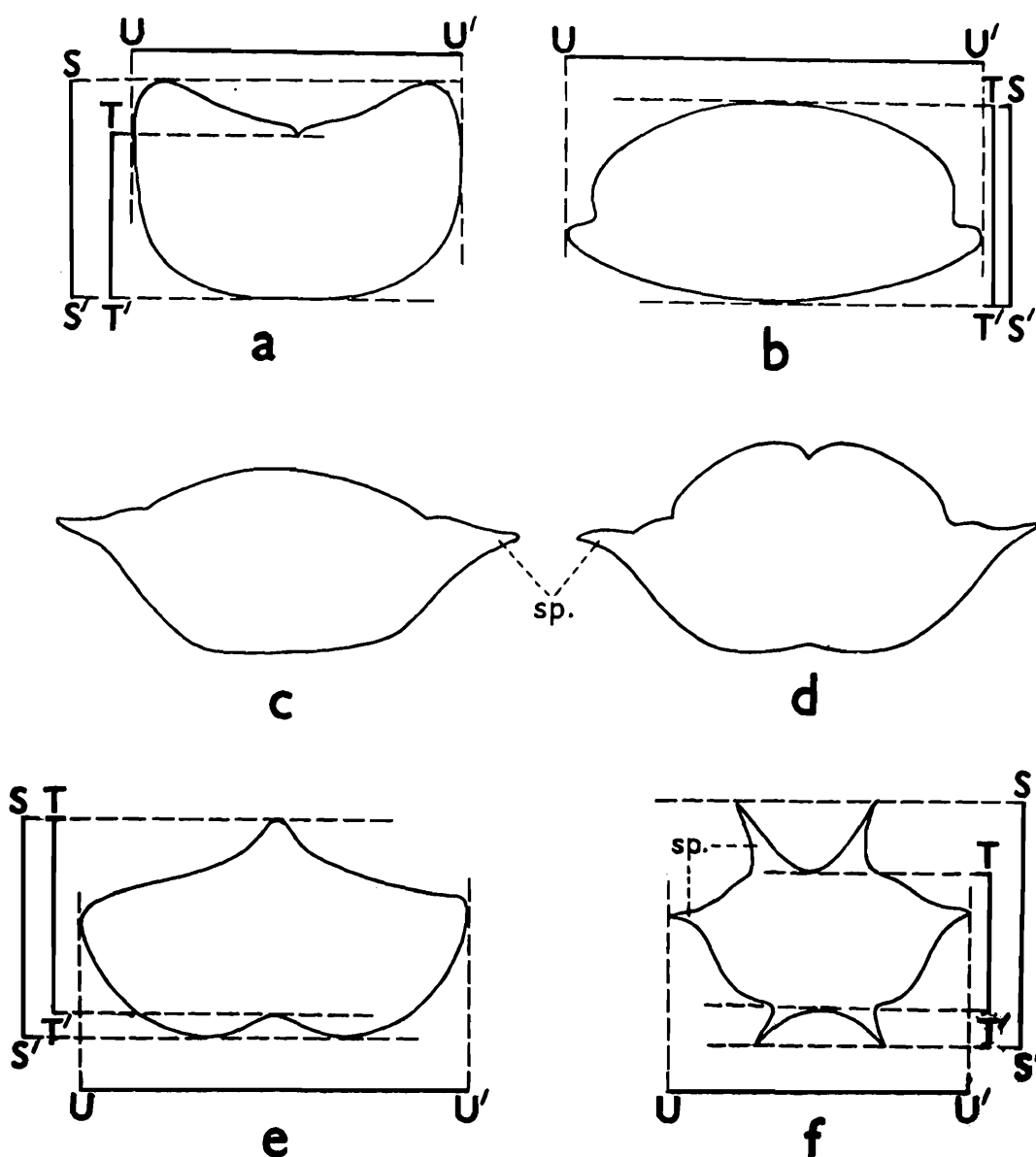

Fig. 47. Pronotum in dorsal view, of: (a) *Postelectrotermes militaris* (Desneux); imago. (b) *Pericapritermes latignathus durga* (Roonwal and Chhotani); soldier. (c) *Syntermes wheeleri* Emerson; soldier. (d) *Syntermes hageni* Holmgren; soldier. (e) *Rhinotermes nasutus* (Perty) (syn. *R. taurus* Desneux); soldier major. (f) *Acanthotermes acanthothorax* (Sjöstedt); soldier major. To show the following measurements: (i) Maximum length of pronotum (line SS'). (ii) Median length of pronotum (line TT'). (iii) Maximum width of pronotum (line UU'). (Ex Roonwal 1970b.)  
sp., spine.

wing suture and the most distal margin of the wing-membrane. Suitable for fully-winged imagoes.

**Note :** This measurement is of course the difference between the 'length of scale' (vide infra) and the 'maximum length of wing with scale' It is useful for comparison when only cast off wings (which are without the scale) are available.

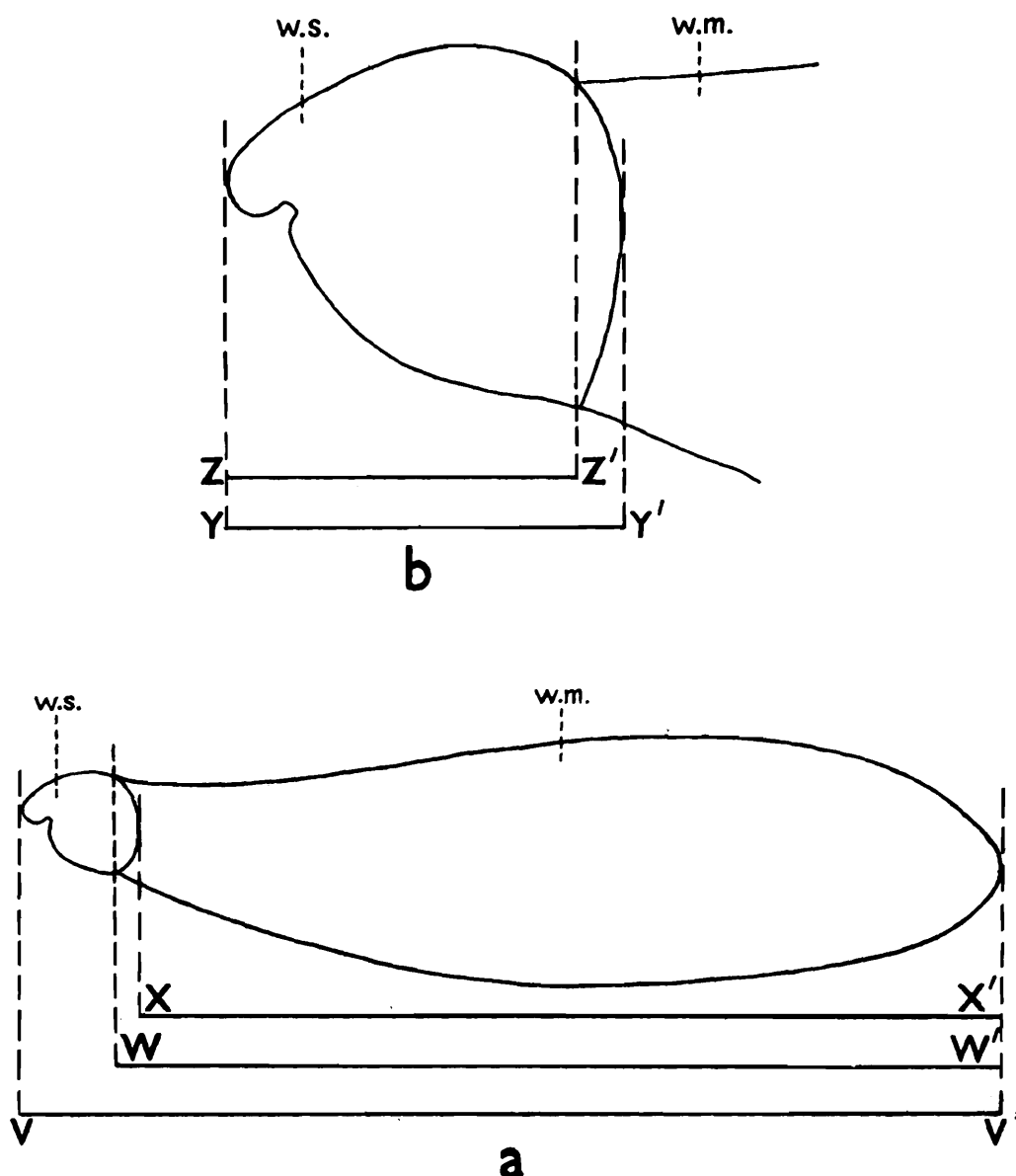

Fig. 48. Outlines of right forewing of *Bifiditermes indicus* (Holmgren), imago, in dorsal view. (a) Complete forewing, with scale. (b) Proximal part, showing scale, etc.; enlarged. To show the following measurements: (i) Length of forewing with scale (line  $VV'$ ). (ii) Maximum length of forewing without scale (line  $WW'$ ) (iii) Minimum length of forewing without scale (line  $XX'$ ). (iv) Maximum length of forewing scale (line  $YY'$ ). (v) Minimum length of forewing scale (line  $ZZ'$ ). (Ex Roonwal, 1970 b.)  
 w.m., wing membrane; w.s., wing scale.

32. **Maximum length of forewing scale** (Fig. 48, line  $YY'$ ). Distance between two parallels marking the most proximal margin of the articular sclerites of the forewing and the most distal margin of the scale-wing suture.

33. **Maximum length of hindwing with scale.**

34. **Minimum length of hindwing without scale.**

35. **Maximum length of hindwing scale.**

These three measurements are as for the forewing, *vide supra*.

*Legs, cerci and styli* (Fig. 49). Occasionally, the leg parts (e.g., femur and tibia) and the abdominal appendages (cerci and styli) are measured.

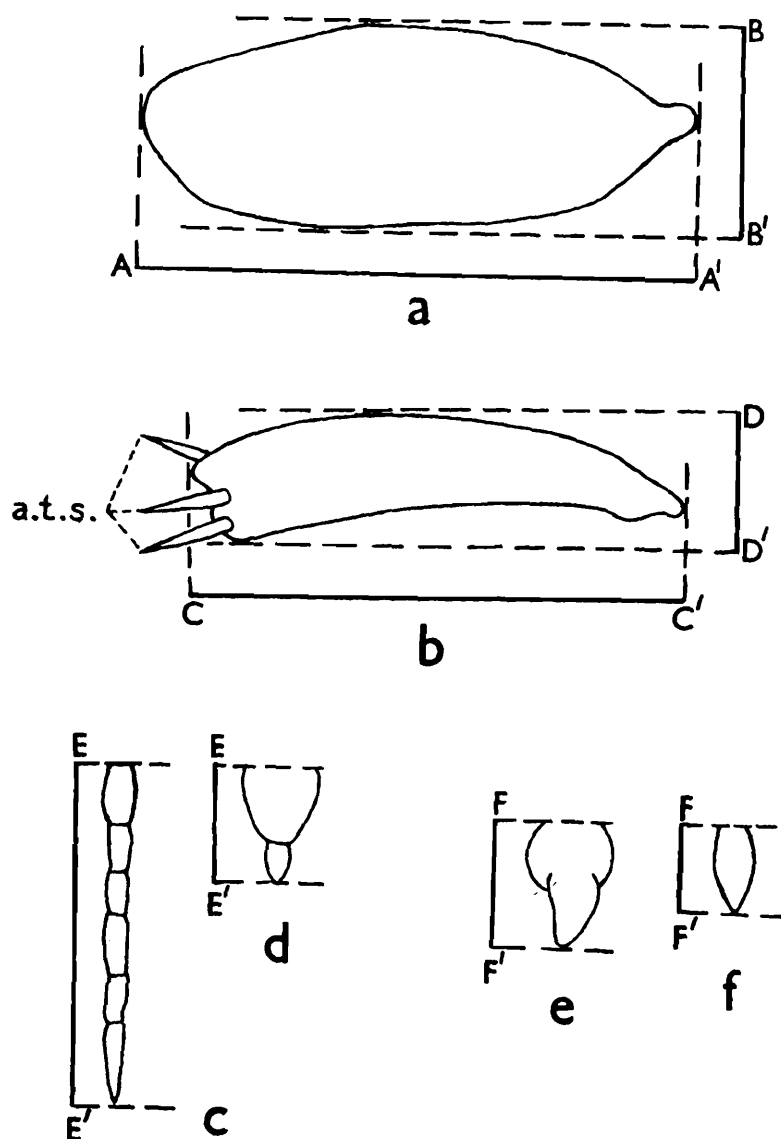

Fig. 49. Leg-parts, cerci and styli of (a) Left middle-femur of *Postelectrotermes militaris* (Dexneux). (b) Left middle-tibia of *Postelectrotermes militaris* (Desneux). (c) Left cercus of female imago of *Archotermopsis wroughtoni* (Desneux). (d) Left cercus of soldier of *Odontotermes obesus* (Rambur). (e) Left stylus of female imago of *Archotermopsis wroughtoni* (Dexneux). (f) Left stylus of soldier of *Odontotermes obesus* (Rambur). To show the following measurements: (i) Length of femur (line AA'). (ii) Width of femur (line BB'). (iii) Length of tibia (line CC'). (iv) Width of tibia (line DD'). (v) Length of cercus (line EE'). (vi) Length of stylus (line FF'). (Ex Roonwal, 1970 b.)

a.t.s., apical tibial spurs.

(v) *Definitions of the more important indices :***1. Head Index A (Width-Length Index - 1)**Maximum width of head with eyes (when present)  

---

Length of head to lateral base of mandibles

Suitable for all castes.

This index, and the two others which follow, give an idea of the 'shape' of the head, i.e., whether it is 'long' or 'broad' It is specially useful for soldiers, except in the Nasutitermitinae for which a separate index, Head Index C, is used, vide infra, No. 3.

**2. Head Index B (Width-Length Index - 2)**Maximum width of head with eyes (when present)  

---

Length of head-capsule

Suitable for all castes.

**3. Head Index C (Width-Length Index - 3)**Maximum width of head with eyes  

---

Length of head without rostrum

Suitable for soldiers with a nasutiform head, as in the Nasutitermitinae.

**4. Head Index D (Height-Length Index - 1)**Height of head excluding postmentum  

---

Length of head to lateral base of mandibles

Suitable for all castes. Is specially useful for soldiers without a nasutiform head.

**5. Head Index E (Height-Length Index - 2)**Height of head excluding postmentum  

---

Length of head without rostrum

Suitable for soldiers with a nasutiform head, as in the Nasutitermitinae.

**6. Head Index F (Height-Width Index)**Height of head excluding postmentum  

---

Maximum width of head with eyes (when present)

Suitable for all castes.

**7. Head Contraction Index (Width Index)**

Minimum width of head

---

Maximum width of head with eyes (when present)

Suitable for all castes, especially soldiers. It provides an idea of the degree of narrowing of the head. (Is the 'Head Convergence Index' of authors.)

**8. Rostrum-Head Index (Length-Length Index)**

Length of head-rostrum

---

Length of head without rostrum

Suitable for soldiers with a nasutiform head, as in the Nasutitermitinae.

**9. Fontanelle Distance Index**

Occipito-fontanelle distance

---

Length of head to lateral base of mandibles

Suitable for all castes possessing the fontanelle.

**10. Fontanelle Rim Index**

Minimum diameter of fontanelle rim

---

Maximum diameter of fontanelle rim

Suitable for all castes possessing the fontanelle. It gives an idea of the shape of the fontanelle.

**11. Labrum Index A (Width-Length Index-1)**

Maximum width of labrum

---

Maximum length of labrum

Suitable for all castes.

**12. Labrum Index B (Width-Length Index-2)**

Maximum width of labrum

---

Median length of labrum

Suitable for all castes.

**13. Mandible-Head Index (Length-Length Index)**

Maximum length of mandible

---

Length of head to lateral base of mandibles

Suitable for all castes, specially soldiers.

**14. *Eye Index***

Minimum diameter of compound eye with ocular sclerite

---

Maximum diameter of compound eye with ocular sclerite

Suitable for all castes where compound eyes are present.

**15. *Lateral Ocellus Index***

Minimum diameter of lateral ocellus

---

Maximum diameter of lateral ocellus

Suitable for all castes where lateral ocelli are present.

**16. *Eye-Ocellus Distance Index A***

Minimum eye-ocellus distance

---

Maximum diameter of lateral ocellus

Suitable for all castes where compound eyes and lateral ocelli are present.

**17. *Eye-Ocellus Distance Index B***

Minimum eye-ocellus distance

---

Minimum diameter of lateral ocellus

Suitable for all castes where compound eyes and lateral ocelli are present.

**18. *Postmentum Index A (Width-Length Index)***

Maximum width of postmentum

---

Minimum (median) length of postmentum

Suitable for all castes, especially soldiers.

**19. *Postmentum Index B (Width Contraction Index)***

Minimum width of postmentum

---

Maximum width of postmentum

Suitable for all castes, especially soldiers.

**20. *Pronotum-Head Index (Width-Width Index)***

Maximum width of pronotum

---

Maximum width of head with eyes (when present)

Suitable for all castes.

USEFUL CHARACTERS FROM INTERNAL MORPHOLOGY  
(Figs. 50-54; and Table 2)

A number of internal morphological characters have been found to show marked differences between taxa-groups, especially the higher ones. Whatever the merits of this arrangement, the practical difficulty of having to dissect a termite every time you want to identify it and determine its placement would prevent most termitologists from using this method extensively. For aid in determining broad phylogenies, however, the internal characters have their uses.

1. *The Alimentary Canal*  
(Fig. 50)

Grassé and Noirot (1954) used the morphology of the alimentary canal and the associated structures of workers for the separation of *Apicotermes*

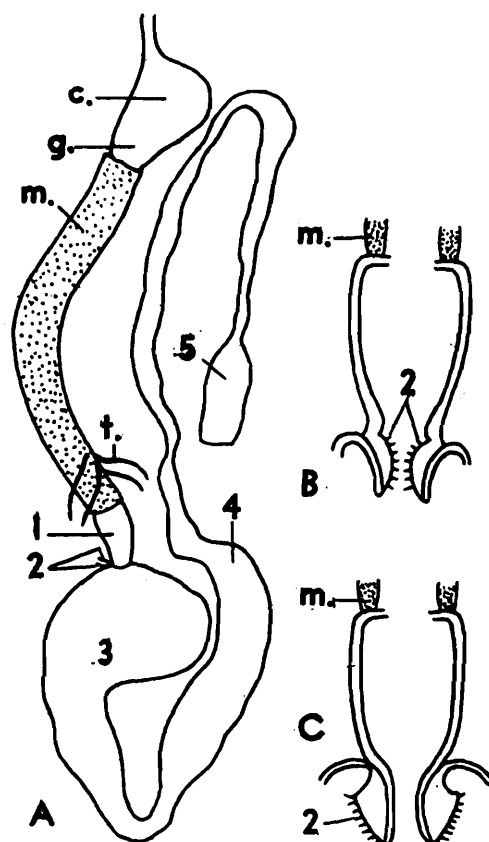

Fig. 50. The alimentary canal in some termites. (Ex Noirot and Noirot-Timothee 1969.) (A) *Allognathotermes hypogeus*, entire canal. Termitinae ("Apicotermatinae" of authors.) (B) First intestinal segment and enteric valve (with *inner* armature) in *Pseudacanthotermes* (Macrotermatinae). (C) Same, in *Eburnitermes* (Amitermitinae) and in "Apicotermatinae"; enteric valve with *external* armature.  
c., crop; g., gizzard; m., midgut; t., Malpighian tubules. 1, first proctodeal segment; 2, enteric valve; 3, paunch; 4, colon; 5, rectum.

and certain other genera of the subfamily Amitermitinae into their new subfamily, Apicotermitinae, and a comparative study of the various subfamilies was made by Noirot and Noirot-Timothee (1969). Sands (1972) used these characters for the study of the soldierless termites of the African members of the '*Anoplotermes* - group' which he has split up into 16 new, mostly monotypic, genera. The characters used are the gizzard and its armature, the relationship of the mesenteron and the proctodaeum, the attachment of the Malpighian tubules and the structure and armament of the enteric valve (Fig. 50).

Johnson (1979) has used the *in situ* coiling of the gut in workers as a diagnostic character. He found that it is possible to sort out, on this basis, both the genera and species of the Termitinae and Apicotermitinae (= Amitermitinae in part). But its value in other subfamilies was limited, particularly in the Macrotermitinae where the gut is almost uniform. According to Salihah (1982) the internal cuticular armature of the oesophagus, crop, proventriculus and rectal valve were sufficiently different to enable recognition of families and, in some cases, even the lower taxa.

## 2. *The Tergal and Sternal Glands*

Ampion (1980) and Ampion and Quennedey (1980) have used the structure and distribution of the tergal and sternal glands in imagoes for distinguishing between genera, families and subfamilies in a limited way.

## 3. *Egg Size, Shape and Structure*

(Figs. 51-54 and Table 2)

### (i) *Size and shape :*

That egg size and shape have broad phylogenetic significance has been established by Roonwal (1973, 1975b). Eggs in the primitive families are larger and more slender than those in the advanced ones. In the families Mastotermitidae, Kalotermitidae, Termopsidae, Hodotermitidae and Rhinotermitidae, the egg is 1.2-1.5 mm long and 0.4-0.5 mm in maximum width; in the family Termitidae the size (length and width) is 0.5-1.0 × 0.20-0.34 mm.

The egg-shape (Fig. 51), as judged by the ratio Width/Length (W/L), is narrow and slender in the primitive families and broad in the higher groups. Three ratio categories are recognised, viz., narrow (0.39 and below),

Table 2. Distribution of egg-shape (ratio Width/Length, W/L) in termites.  
(Adapted ex Roonwal, 1970b).

Status of family	Family	Groups of W/L Ratio and number of species in them			Total No. of species
		Narrow (0.39 and below)	Medium (0.40-0.44)	Broad (0.45 & above)	
Primitive	1. Mastotermitidae	1	0	0	1
	2. Kalotermitidae	5	2	0	7
	3. Termopsidae	1	1	0	2
	4. Hodotermitidae	0	1	0	1
Intermediate	5. Rhinotermitidae	2	2	1	5
Advanced	6. Termitidae	0	2	13	15

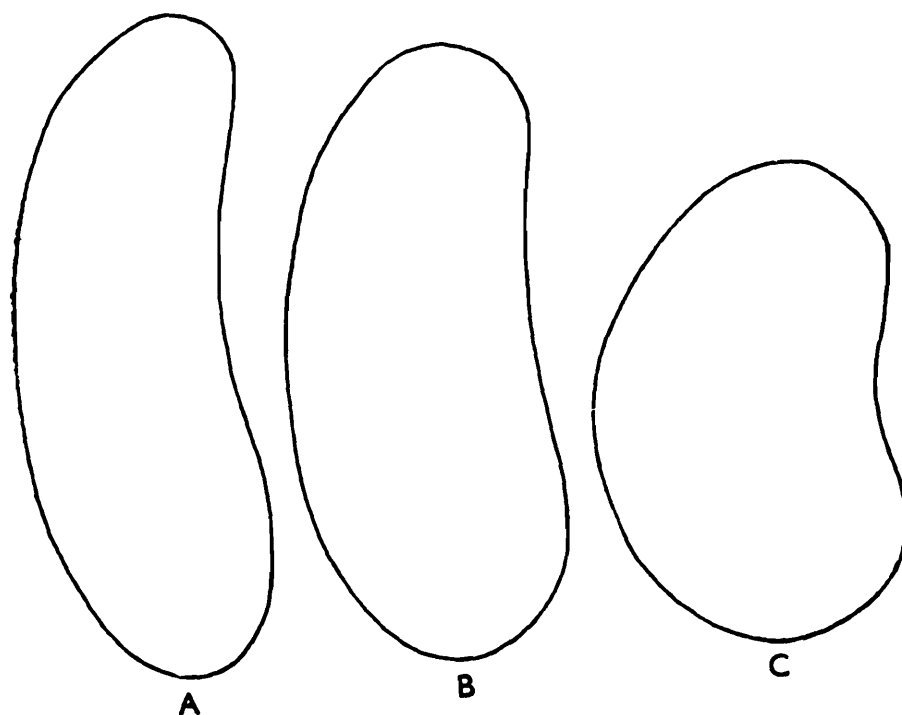

Fig. 51. Types of termite eggs as regard. shape (Width/Length Ratio). (A) Narrow type (ratio 0.39 and lower). (B) Medium type (ratio 0.40-0.44). (C) Broad type ratio (0.45 and higher). (Ex Roonwal 1975b).

medium (0.40-0.44) and broad (0.45 and above), the distribution of the 31 species studied is as in Table 2. The primitive families lie mostly in the 'narrow' group, the advanced one (Termitidae) mostly in the 'broad' one, and in the intermediate family (Rhinotermitidae the ratio is more evenly distributed.

(ii) *Structure* (Figs. 52-54).

The egg-wall sculpturing and the micropylar apparatus show certain distinguishing characters, and the limited information available has been examined by Roonwal and Rathore (1979).

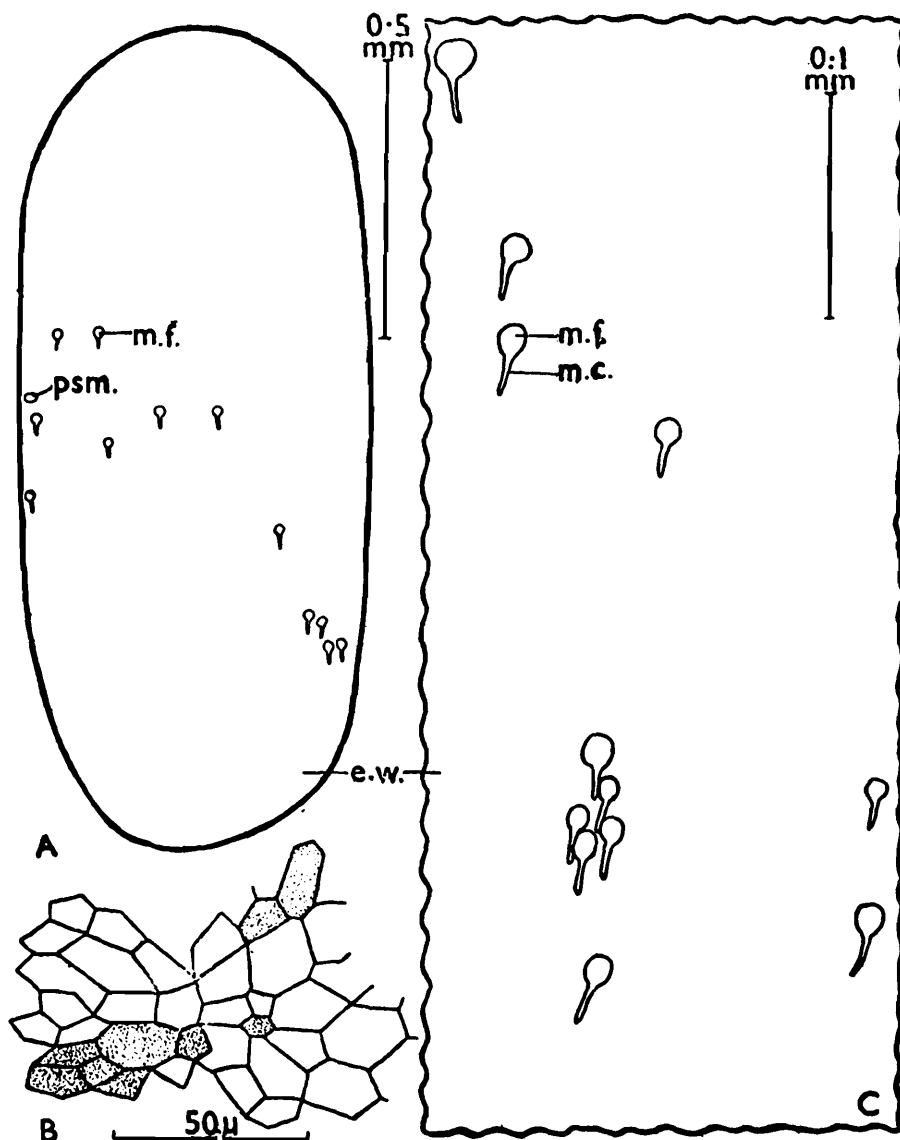

Fig. 52. Egg and egg-wall of *Anacanthotermes macrocephalus* (Ex Roonwal and Rathore, 1979.) (A) Whole empty egg-shell. (B) Portion of egg-shell near anterior poles to show sculpturing. (C) Part of egg-shell to show micropyles.

e.w., egg-wall; m.c., micropylar canal; m.f., micropylar funnel; psm., pseudomicropyle.

**Egg-wall sculpturing :** In the majority of species studied, the egg-wall is smooth, glossy, transparent and structureless. In *Anacanthotermes macrocephalus* it is sculptured (Probably on the exochorion) with a pattern of fine polygonal ridges, particularly near the two poles (Fig. 52) (Roonwal and Rathore 1979); and a nearly similar sculpturing occurs in *Kalotermes flavicollis* (Truckenbrodt 1971).

**Micropylar canals :** The micropylar apparatus consists of a number of small, funicular canals in the egg-wall, with a broad outside funnel and a narrow canal opening inside, on the convex (dorsal) wall of the egg. Their number is usually small, generally 7-18, but in *Kalotermes flavicollis* there is a wide variation from 5-61, mostly 17-40. The width of the outer funnel varies between 8-26 $\mu$ m, the range within each species being generally narrow. The length of the canal varies considerably (6-32  $\mu$ m) both within a species and from one species to another. Canals in the primitive families are generally long (13-32  $\mu$ m), while those in the advanced ones are smaller (6-15  $\mu$ m). Regarding the distribution of the canals on the egg-wall, Roonwal and Rathore (1979) have recognised two types, viz., a diffuse type and a concentrated type (Fig. 53). In the *diffuse* type the canals are distributed over a relatively wide area about the middle of the egg. In the *concentrated* type the canals are arranged in a single neat row (or sometimes

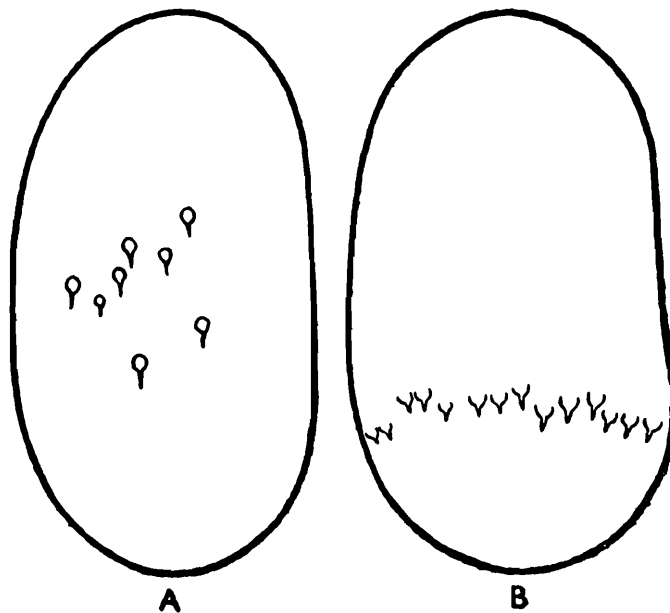

Fig. 53. Termite eggs, showing two types of distribution of micropylar canals. (Ex Roonwal and Rathore 1979.) (A) Diffuse type. (B) Concentrated type.

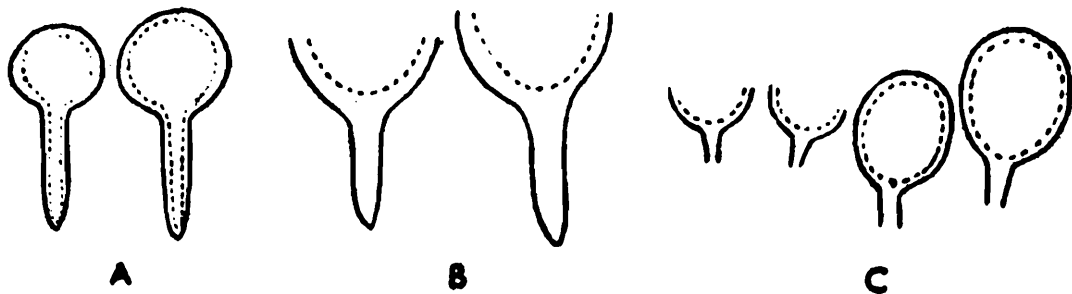

Fig. 54. Types of micropylar funnels in Isoptera. (Ex Roonwal and Rathore 1979.)  
 (A) Complete funnels. (B) Half funnels. (C) Mixed.

rather irregularly, one over the other) near the posterior pole of the egg. The diffuse type appears to be more common in the primitive groups, and the concentrated type in the advanced ones. The funnel structure varies, and in this respect the species can be separated into three groups (Figs. 53, 54) without any phylogenetic relationship, thus: with complete funnels, round or oval; with half-funnels; and mixed.

These egg characters, while being useful in suggesting broad phylogenetic relationship, can hardly, for obvious reasons, be used for differentiating the lower taxa, even though in some cases specific differences may be found to occur. Thus, while in *Odontotermes obesus*, complete micropylar funnels occur, in *O. brunneus* they are of the 'mixed' type.

### TAXONOMIC VALUE OF SECONDARY STRUCTURES

Secondary structures sometimes provide supplementary information of taxonomic value. Of these, perhaps the more important ones are the structures of termite mounds and nests and related constructions. Generally, a species has its own characteristic type of mound and nest, and this applies to shape, size, the arrangement of fungus combs inside the mound, etc. While this seems to be the rule, there are important exceptions, and the taxonomist must not place excessive reliance on these secondary structures. Data on wide intraspecific variations which occur in mound and nest construction in various species from many regions (Oriental, Australian, Neotropical and Ethiopian) have been examined by Roonwal (1978c). A summary of the Indian species will suffice for our present purpose.

**Macrotermitinae** : In *Odontotermes assmuthi* in southern India tall earthen mounds are built, but in the north no mounds are built and the nest is entirely subterranean. In *O. brunneus*, five types of mounds are built. In some cases, different types may occur within a few kilometres of each other. *O. feae* generally nests underground, but low earthen mounds are occasionally built both in India and in Thailand. *O. horni* in India and Sri Lanka is entirely subterranean, but in Kampuchea (Cambodia) it builds a metre-high earthen mound. *O. obesus*, which is the common Indian mound-building species, builds five different types of large earthen mounds; a sixth situation is the complete absence of a mound, the species nesting entirely underground, as seen in the Indian Desert.

**Nasutitermitinae**: *Trinervitermes biformis* (syn. *T. heimi*) in northern India is entirely subterranean; in the south it builds low, dome-shaped mounds.

It is pertinent to emphasise here that these intraspecific variations in secondary structures appear to be genuine, and not due to faulty taxonomy. In a few cases, an ecological relationship seems to exist, as in the Indian Desert where *Odontotermes obesus* makes no mounds, and nests are entirely underground except in a few places where subsoil water is available as on the earthen banks of water reservoirs where mounds are built. An alternative explanation that has been advanced is that the differences are in fact an expression of the occurrence of 'incipient species' which have acquired behavioural differences but not morphological ones yet; no proof, however, is available.

## POLYMORPHISM, SEXUAL DIMORPHISM AND SEX RATIOS

### 1. *Polymorphism* (Fig. 55)

One of the important characteristics of the order Isoptera is the occurrence of polymorphism in all the known species. First, two main types of polymorphism can be distinguished in each species, viz., the occurrence of the reproductive castes or adults and the sterile castes; and secondly, polymorphism within each caste.

Three types of reproductive castes are distinguishable : (1) The alate or fully winged (macropterous) form (also called adults of the first form)

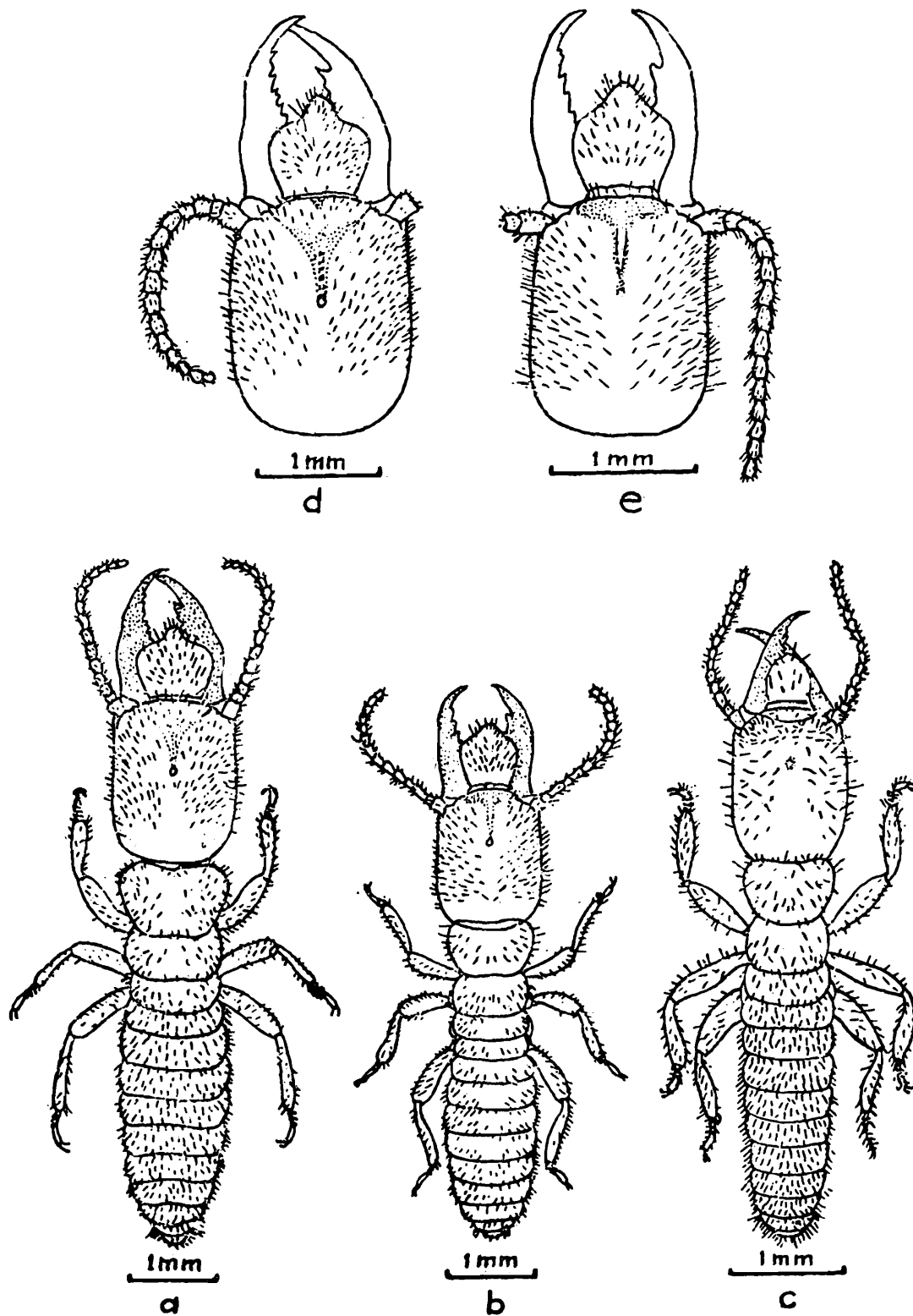

Fig. 55. *Psammotermes rajasthanicus*, soldiers, showing polymorphism. Three types of soldiers occur. (a), (b), (c). Soldiers major, medium and minor respectively. (d), (e). Heads of major and minor soldiers respectively. Not to same scale. (Ex Roonwal and Bose 1964.)

which, after a brief aerial flight, returns to a hidden mode of life underground or in dry or moist wood, including living trees. It is usually well pigmented and dark, and is to be regarded as the ancestral form from which all the others are derived by reduction. (2) A brachypterous type (also called adults of the second form). Members do not swarm out; the body is lightly pigmented, and wings are small and nymphal in appearance. (3) An apterous type (also called adults of the third form). Like the previous type, members do not swarm out. There are no wings and pigmentation is almost absent. Is relatively rare.

The sole function of reproductives is to reproduce. Usually, a single pair (sometimes a few pairs) are present in a well developed colony. In older colonies, the queen, especially in the higher termites, undergoes physogastry and attains a large size; the king remains unchanged.

Among the other castes, two main forms occur, viz., workers and soldiers. Workers broadly resemble the reproductives in general appearance but are marked by the complete absence of wings or their rudiments, paler coloration and smaller size. They are the most numerous members of a colony (forming about 90 per cent or more of the total population), and perform practically all the functions of a colony except defence, and reproduction. The worker caste is fully developed in the higher termites; in the lower termites, however, they remain 'immature' and are then called pseudoworkers (or pseudergates).

The soldiers constitute the most specialised members of a colony, and their head-capsules and mandibles often assume a large size and bizarre shapes. Two main shapes are distinguishable, viz., the mandibulate and the nasute. In the former the mandibles are large and well developed. In the latter (confined to the subfamily Nasutitermitinae) the head is prolonged into a longish snout or nose at whose tip lies the opening of the fontanelle gland which ejects a defensive secretion; the mandibles are greatly atrophied and are nonfunctional. The soldier caste forms only a small proportion of a colony population, usually well below 10 per cent. In a few genera, however, as in *Anoplotermes*, etc., the soldier caste is absent.

The second type of polymorphism is that which occurs within each caste. The most common form of it is sexual dimorphism (vide infra), and this is the only type which is found in the reproductive forms. In the workers and soldiers, however, other types also occur, the most common

of which is the occurrence of two kinds of individuals, distinguishable from each other mainly by differences of body size and the shape, etc. of some body parts such as labrum and mandibles. The most extreme degree of polymorphism is found among soldiers, especially in the lower termites. In the genus *Psammotermes* (Rhinotermitidae : Psammotermitinae), for example, several species have three types of soldiers (Fig. 55), but workers are either dimorphic or monomorphic. Dimorphic forms are usually called major (large) and minor (small); trimorphic ones are called major, medium and minor, or, alternatively, 1, 2, 3, etc., thus soldier<sup>1</sup>, soldier<sup>2</sup>, soldier<sup>3</sup>.

Apart from its biological significance, polymorphism is of importance in taxonomy, and the different types of individuals call for separate descriptions to make identifications possible. The soldiers provide the most striking differences. The reproductives also provide good differences, but workers (which are in morphological characters merely immature reproductives whom they resemble greatly) are difficult to separate.

## 2. Sexual Dimorphism (Figs. 56-61)

While the occurrence of sexual dimorphism in certain external abdominal characters in imagoes has been known for long, such dimorphism in other characters was practically unknown until recent years, and the subject has been examined in detail by Roonwal (1975d).

The 7th, 8th and 9th sterna differ in the two sexes (vide supra). These sterna are 'normally' developed in males where they are complete and well developed. In females, sternum 7 is greatly enlarged to form the subgenital plate (Fig. 26). Sterna 8 and 9 are reduced and modified and are often so covered by the enlarged seventh sternum as to be almost invisible, though in some species they can be clearly seen; they may be reduced to a pair of widely separated plates, or the ninth sternum may still remain entire (*O. obesus*). Secondly, the styli, which are a pair of long or short unjointed appendages on the posterior margin of the ninth sternum, are usually present in alate males and absent in alate females (in immature females they may be present or absent). Styli are usually long in the primitive families and short and often inconspicuous in the advanced ones. Thirdly, in the older females of several species, the abdomen undergoes considerable enlargement (physogastry) by the extension of the elastic intersegmental membranes to accommodate the greatly enlarged ovaries; the abdomen in males remains unaffected.

Although sexual dimorphism has now been shown to occur in a large number of characters, both morphological and nonmorphological, the degree of dimorphism is small and is sometimes discernible only by statistical tests. Such dimorphism has so far been demonstrated in over 40 species and in all the castes, but mainly in imagoes and workers. Dimorphism has been found in 38 morphological and 4 non-morphological characters (Figs. 56-61). Among the morphological characters may be mentioned the total length, length and width of head, postclypeus, antennae,

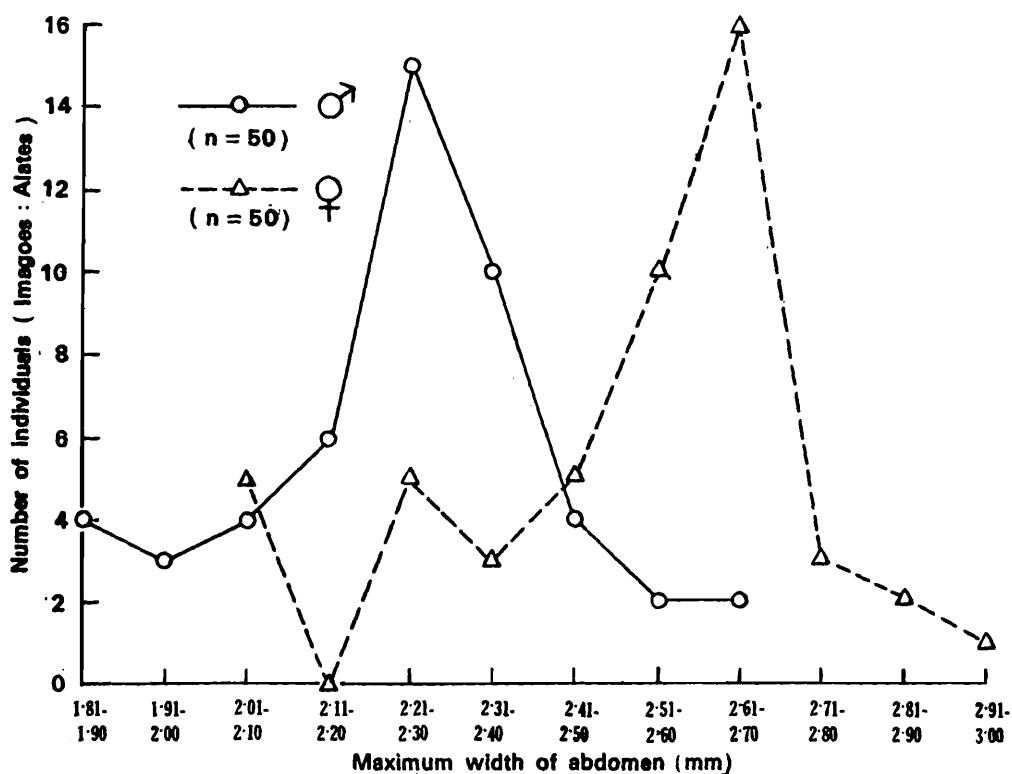

Fig. 56. *Microtermes obesi*. Sexual dimorphism in maximum width of abdomen. (Ex Roonwal 1975 d).

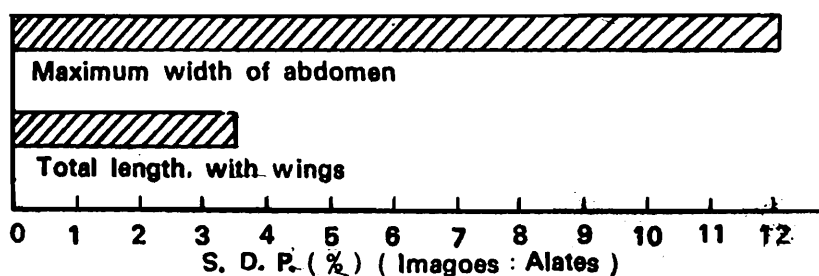

Fig. 57. *Microtermes obesi*. Sexual dimorphism percentage in total length (with wings) and maximum width of abdomen. (Ex Roonwal 1975 d).

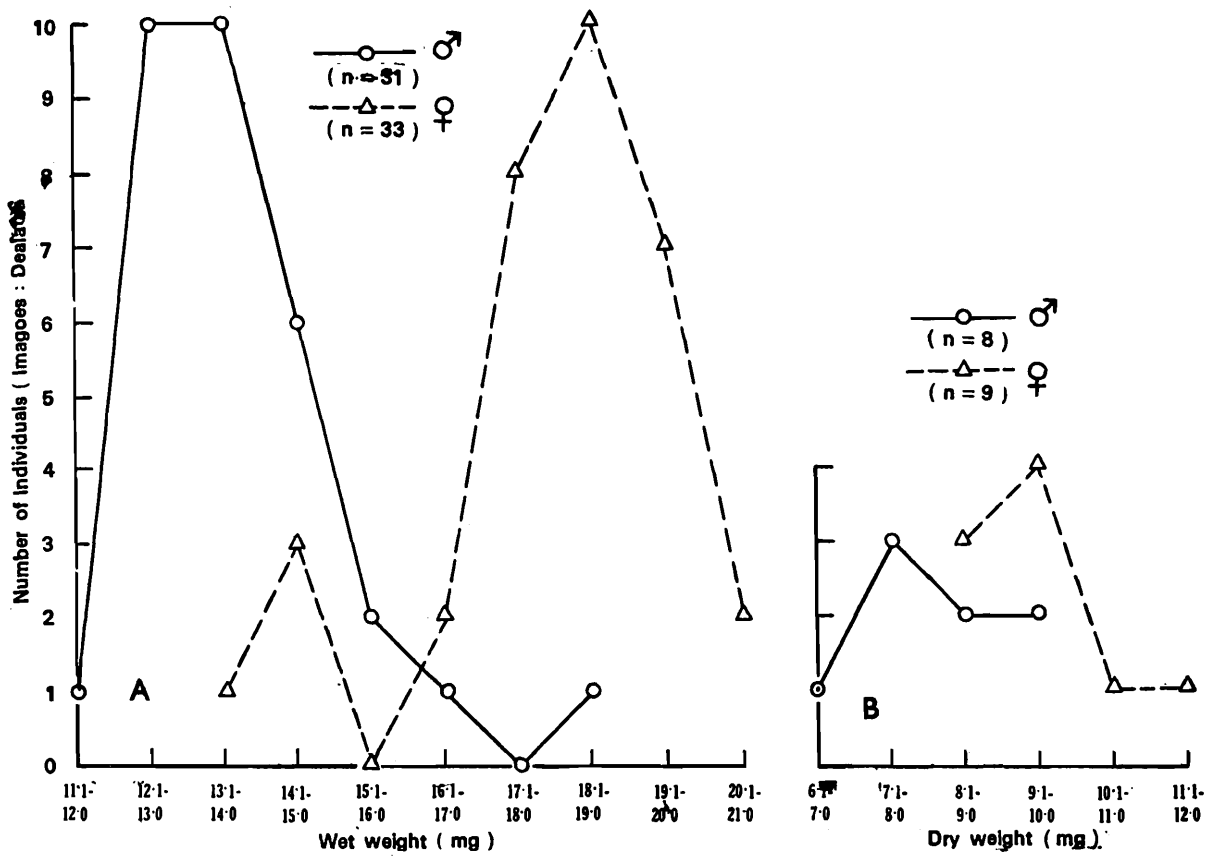

Fig. 58. *Microtermes obesi*, dealate imagoes. Sexual dimorphism in body weight. (Ex Roonwal 1975 d.) (A) Wet Weight. (B) Dry weight.

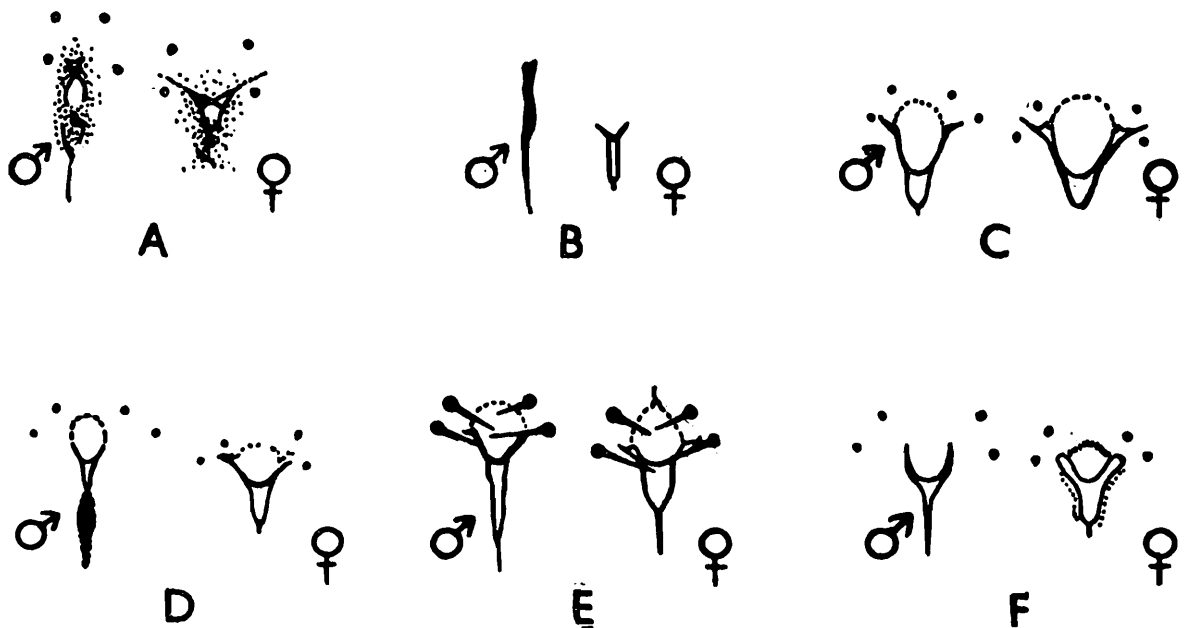

Fig. 59. Fontanelle from head dorsum of several *Nasutitermitinae*, showing sexual dimorphism. (From Sands 1957, ex Roonwal 1975 d.)

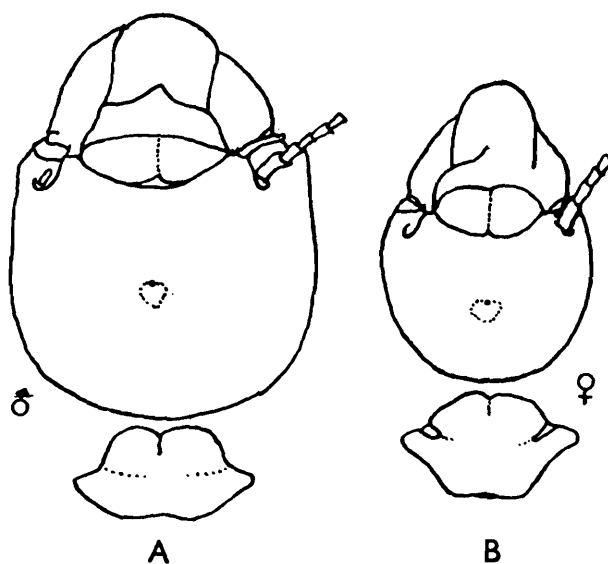

Fig. 60. Head and pronotum of workers of *Macrotermes natalensis*, in dorsal view, to show sexual dimorphism. (Ex Roonwal 1975 d.) (A) Male. (B) Female.

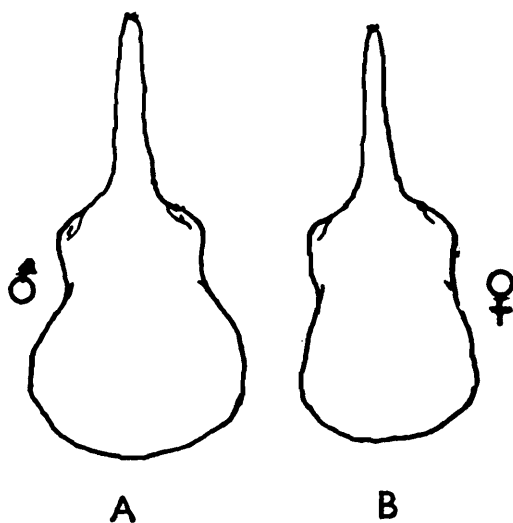

Fig. 61. Head of soldiers of *Coarctotermes doriae* in dorsal view, to show sexual dimorphism. (A) Male. (B) Female. (Ex Roonwal 1975 d.)

pronotum, legs, wings, abdomen, etc., the shape and size of the fontanelle, the colour of the posterior abdominal sterna, the inter-segmental pubescence of abdomen, the cuticular folds in the intersegmental membranes of the abdomen, and the tracheal network in the abdomen. Among the non-morphological characters are the wet and dry weights, moisture content and oxygen consumption in imagoes; and in the social function of workers in a colony (*Acanthotermes acanthothorax*).

The following general conclusions may be drawn : (1) Sexual dimorphism occurs in all castes but seems to be more common in imagoes and workers than in soldiers. (2) Both morphological and non-morphological characters show such dimorphism. (3) In imagoes males are generally smaller than females, but in workers the reverse generally occurs. (4) There is a tendency for sexual dimorphism to be weak or absent in the more primitive families.

### 3. Sex Ratios

The proportion of the two sexes in populations of termite reproductives is of considerable biological significance, and some authors have attributed a selective value to unequal sex ratios under certain conditions. Then, the production of females alone in a population is attributable to the occurrence of parthenogenesis. The information which is available for imagoes has been examined in some detail by Roonwal (1975 d).

Sex ratios in primary reproductives (winged imagoes which swarm out in certain seasons) may be either equal (less common) or unequal. In the latter category, either one sex or the other may predominate—males in a few species and females in several others. No phylogenetic relationship is discernible with regard to these various types, each being found in both primitive and advanced termites.

Equal or nearly equal ratios have been found in *Neotermes tectonae*, *Reticulitermes flavipes*, *Odontotermes assmuthi* and *Microtermes obesi* and others. Among those with unequal ratios (which are more common, c. 78%), males predominate in some (*Neotermes connexus*, *Anacanthotermes macrocephalus*) and females in others (*Reticulitermes lucifugus*, *Trinervitermes* spp., *Microcerotermes raja*).

In parthenogenesis, only female imagoes are produced (all imagoes in *Bifiditermes beesoni* (Chhotani 1962 b) and some in *Reticulitermes lucifugus*). Neotenic (supplementary reproductives) may be either exclusively females (*Microcerotermes heimi*, *M. beesoni*) or of both sexes (*M. amboinensis*, *M. fletcheri*).

Almost nothing is known about the mechanism of sex determination in termites beyond the fact that both sexes are diploid (unlike the social Hymenoptera where males are haploid) and that both sexes are differentiated in the various castes. According to Mendelian genetics, a 1:1 sex ratio

in the  $F_1$  generation can occur only if one of the sexes is heterozygotic with regard to sex determiners on either autosomes or sex chromosomes. This equal ratio may be disturbed in various ways, but since males can mate with many females, a 1:1 sex ratio is not essential for species propagation. In termites, soon after the nuptial flight, the two sexes pair individually for life—a male and a female usually undergo a tandem behaviour for a while and then settle down in a hole or crevice. Later on, the two may be imprisoned in a royal chamber constructed by the workers of the colony. In practice, therefore, polygamy is not possible (whenever multiple queens have been found in a royal chamber, they are almost always accompanied by multiple kings), and a 1:1 ratio may offer a selective advantage. Jones et al. (1982) have deduced that populations with a 1:1 alate sex ratio in a significant proportion of the colonies of a species are characterised by an extended flight season, nonsynchronous flights from different colonies, and small number of alates in each swarm; populations with a significant number of colonies with skewed sex ratios are characterised by a brief flight season, synchronous flights from many colonies, and large number of alates in each swarm. Since flight synchrony is largely ecologically induced (as in deserts, with a highly restricted wet season), it is difficult to see any real biological relationship between synchrony and sex ratios.

## BIOLOGY AND ECOLOGY

(Fig. 62)

All termites are social and live in colonies of varying sizes from a few hundred individuals to well over a million. Most species live underground where they construct their nest, and some live and breed in both dry and living wood. A few species construct large earthen dwellings or mounds above the ground, and some build nests of wood-carton on trees and elsewhere.

### 1. *Life-history*

The life-history differs from species to species in detail, but the general pattern is briefly as follows (Fig. 62): A colony consists mostly of the workers, a small proportion of soldiers, and usually a single reproductive pair, the so-called king and queen, which may be imprisoned by the workers in a sealed 'royal chamber' with a few holes just large enough to allow the exit and entry of workers and soldiers; the royal pair itself is too large to

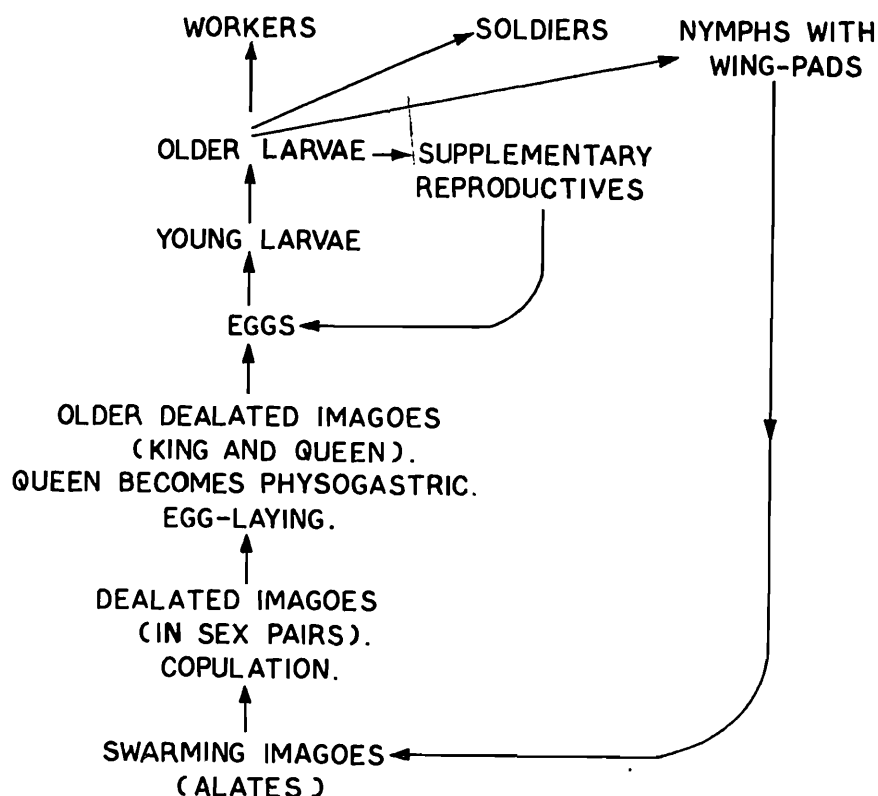

Fig. 62. Diagram to show the generalised life-history of a termite. (Ex Roonwal 1979 b.)

escape through these holes. In some colonies, several kings and queens may occur.

Normally, the eggs, which the queen produces almost continually throughout a life of several years (in some species, almost an egg per few seconds), develop into workers and soldiers only. Periodically, however, the eggs develop into winged reproductive forms which fly out of the colony in swarms. After a short nuptial flight, the insects cast off their wings, undergo a sort of courtship, and settle down in pairs to found a new colony. In a few days, the first batch of 10 or 20 eggs is laid. They hatch out in 15 or 20 days (depending upon air temperature) into small, whitish, soft-bodied larvae. The latter undergo a series of moults and ultimately, in a few weeks, become functional workers. Later on, more eggs are laid, and develop into soldiers as well, and periodically into alates. The alates swarm out and repeat the cycle. If the primary reproductives die or are removed, some of the young larvae develop into supplementary reproductives which, however, do not develop wings but are nevertheless capable of producing viable eggs which perpetuate the colony.

## 2. Habitats

Aspects of the ecology of Indian termites have been discussed by Beeson (1941, 1961), Sen-Sarma (1974), Roonwal (1979 b) and others. Ecologically, termites can be grouped into several kinds, depending upon the habitats in which they live and breed, thus :

### 1. Mainly Wood-dwellers :

(a) Damp-wood species : Some Kalotermitidae (*Bifiditermes*, *Postelectrotermes*, *Neotermes*, *Glyptotermes*) and Termopsidae (*Archotermopsis*).

(b) Dry-wood species : Some Kalotermitidae (*Cryptotermes*).

### 2. Mainly Ground-dwellers :

(a) Subterranean (soil-dwelling) species. Hodotermitidae (*Anacanthotermes*), Rhinotermitidae (*Psammotermes*, *Coptotermes*, *Heterotermes*, etc.) and Termitidae (*Speculitermes*, *Amitermes*, *Termes*, *Odontotermes*, *Microtermes*, etc.) and Indotermitidae.

(b) Mound-builders : Some Termitidae (*Odontotermes*, etc.)

(c) Carton-nest builders : Some Termitidae (*Microcerotermes*, *Nasutitermes*, *Trinervitermes*, etc.).

Certain ecological habitats are discussed below in some detail.

(i) *Termite nests and mounds* : The wood-dwellers (Kalotermitidae, Termopsidae, some Rhinotermitidae) build nests in dead, decaying or even living wood. The nests are often nothing but galleries with or without chambers for eggs and young larvae. Some of the wood-dwellers, however (Coptotermitinae), build carton nests made of chewed wood, excreta and some soil particles glued together into irregularly-shaped, sponge-like masses. The ground-dwellers make various types of nests which may be wholly subterranean (most species), or partly subterranean and partly raised into earthen mounds (several members of the Termitidae), or carton nests in wood such as trees and logs (*Coptotermes*, Roonwal 1954a, 1959; Roonwal and Chhotani, 1962b, 1967a), carton nests partly buried in the ground (*Microcerotermes*, Roonwal 1979b) and arboreal carton nests (many members of the Nasutitermitinae, Chhotani and Bose 1979).

The true mound-builders in India are confined to the family Termitidae where several members of the genus *Odontotermes* and one species of

*Trinervitermes* build earthen mounds. The mound is made of earth, compacted with saliva. It is a discrete structure which is often characteristic of each species.\* Some of the mound-builders also cultivate fungi for which they make special rounded, spongy structures, the fungus-combs, on which the fungi are grown. Inside the mound of a colony lies, underground, the royal chamber, usually with a single royal pair, although sometimes several pairs may occur, and also chambers which serve as egg-depositories and nurseries. The principal species of *Odontotermes* which build mounds are : *anamallensis*, *assmuthi* (not always), *brunneus*, *feae* (occasionally), *gurdaspurensis*, *kushwahi*, *microdentatus*, *obesus*, *parvidens* (occasionally), *redemanni* and *wallonensis*.

As based on their internal structure, there are two types of mounds, viz., unilocular and multilocular. A unilocular mound contains a single large chamber situated at or a little below the ground-level for the lodgement of a single large fungus comb (*Odontotermes obesus*). A multilocular mound contains several chambers of various sizes, both above and below the ground-level, in each of which is lodged a single, rounded fungus comb (*Odontotermes redemanni*). In addition to these fungus-chambers, the mounds of both types have a series of intercommunicating galleries, both large and small, for the movement of the active members of the colony, viz., the soldiers, workers and the larger larvae and nymphs.

Mounds of *Odontotermes obesus*, which rise as high as about 2.5 m. above the ground, are a conspicuous feature in the deciduous forests all over the plains of northern India and a considerable portion of the Peninsula. They are tall and subcylindrical and have a ring of six or seven buttresses all around. At higher elevations (c 1300-1400 m) in the Himalayas, the mounds are low. The situation in Rajasthan provides an interesting example of ecological adaptation. Here *O. obesus* constructs mounds only in the south-eastern portion which is wetter and has a cover of deciduous forests; in the arid western and northern portions the species, though common, is entirely subterranean and does not construct mounds except in selected situations such as the earthen walls (*bunds*) of water reservoirs where moisture is available (Roonwal 1976, 1978c, 1979b). Mounds of

---

\*Some species, however, show a remarkable degree of intraspecific variation; a species may construct 4 or 5 different types of mounds (Chhotani 1977a, Roonwal 1978c).

*O. redemanni* are tall and subconical to subcylindrical but lack the buttresses. Other species build dome-shaped or semi-dome-shaped and relatively low mounds which in some species (*O. wallonensis*) have on the surface a number of open-mouthed chimneys of problematic function.

Through mound-building, termites may affect the fertility of the soil (see Sen-Sarma 1974 for discussion).

(ii) *The wood-dwellers* : Moist wood is preferred by several wood-inhabiting species such as *Archotermopsis wroughtoni* (Imms 1919) and some species of the genera *Bifiditermes*, *Kaloterme*s, *Neoterme*s, *Glyptoterme*s, *Postelectrotermes*, *Stylotermes*, etc., while others (the dry-wood termites) prefer dry and seasoned wood (all members of the genera *Cryptoterme*s, *Coptoterme*s and *Heteroterme*s, and a few others. *Coptoterme*s and *Heteroterme*s must have close association with the ground soil where they live in subterranean colonies. It is fortunate that *Neoterme tectonae*, which is a serious pest of standing teak in Java, is not found in India and Burma though teak is grown here too. Occasionally, however, standing teak in India is attacked and killed by *Odontoterme parvidens* (Roonwal, 1954d).

Species which destroy wood-work in buildings may be divided into two groups : (i) Dry-wood species which live entirely in dry wood, such as beams, pillars, doors and furniture; and (ii) subterranean species which attack wood in buildings but often breed underground in the soil. The more important species damaging buildings in the Indian Region are the following :

Dry-wood species : *Cryptoterme bengalensis* and *C. dudleyi*.

Subterranean species : *Heteroterme ceylonicus*, *H. gertrudae*, *H. indicola*, *H. malabaricus*, *Coptoterme ceylonicus*, *C. formosanus*, *C. gaurii*, *C. heimi* (Syn. *C. parvulus*), *Odontoterme ceylonicus*, *O. feae* and *O. redemanni*.

Through their interaction with living plants, termites cause enormous damage to agricultural crops, orchards and plantations.

(iii) *Temperature and humidity* : Termites are highly sensitive to air temperature and relative humidity and the position has been reviewed by Sen-Sarma (1974). High humidities are preferred as a rule and each species has its own preference; but water-logged areas are avoided by all. Under

experimental situations, the survival time of termites in low humidities in groups (say 500 or more) is higher than in isolated individuals. This difference has been variously explained as due to higher trophallaxis on the one hand and, on the other, to decreased evaporation of water from the body surface in grouped individuals which tend to huddle together and thus expose a smaller area of the body surface.

### 3. *Inquilines*

Inquilines are animals which commonly live in the abode of another animal. Termites provide several such examples. In India *Microtermes obesi* is frequently found living permanently in the walls of the earthen mounds or nests of *Odontotermes* spp., especially *O. obesus*, *O. feae* and *O. microdentatus*. *Dicuspiditermes incola* in India and Sri Lanka is often found in the nests or mounds of *Odontotermes redemanni*, *O. ceylonicus* and *Hypotermes obscuriceps*. Though living in the same habitat, the different species have their own separate galleries and seldom encounter one another. When making field collections from mounds which harbour these inquilines, the different species get mixed up in the same vial and pose problems in identification, especially of the workers where the distinguishing characters are not clear.

### 4. *Termitophiles*

Certain arthropods habitually and permanently live and breed in termite colonies and the associations are specific. Such animals are known as termitophiles. These arthropods belong to several groups, viz., Crustacea (isopoda), Diplopoda (millipedes), Arachnida (spiders, etc) and insecta (Collembola, Thysanura, Coleoptera, Diptera, Hemiptera, Hymenoptera and Lepidoptera). The termitophiles often show many morphological adaptations to the new mode of life, such as physogastry, etc. The most commonly occurring termitophiles are beetles, especially those belonging to the family Staphylinidae. To a limited extent, the specificity of termitophiles helps in clarifying the phylogenetic relationships of termite groups.

## DISTRIBUTION AND ZOOGEOGRAPHY

### 1. *Distribution*

(Figs. 63-67; and Pl. 5)

The present day distribution of a species depends upon a complex of several factors, both past and present, mainly climate, soil, geology,

vegetation cover, past evolutionary history and life-habits; also human intervention. In the well-worked area of Rajasthan (324,274 sq. km), two-thirds of which is desertic and constitutes the Thar Desert, of the 32 species known to occur, 5 occur almost exclusively in the western arid zone, 3 exclusively in the south-eastern wet zone, and the remainder are more versatile (Roonwal 1976).

The order Isoptera, of which nearly 2,000 species are known (new ones are being constantly discovered and perhaps 20 per cent of the total fauna still remains to be discovered, especially from remote areas), is confined to the tropical and subtropical parts of the world and covers all the continents (Fig. 63). The northern and southern limits roughly coincide with the mean annual isotherm of 10°C (50°F) (approximate latitudes 40°N and 40°S). The distribution of fossil termites extends well beyond these limits.) Temperature is probably the limiting factor, and since termites need a great deal of moisture (but not excessive free water), they generally avoid extremely arid areas. With artificial mitigation of these limitations (as in heated human

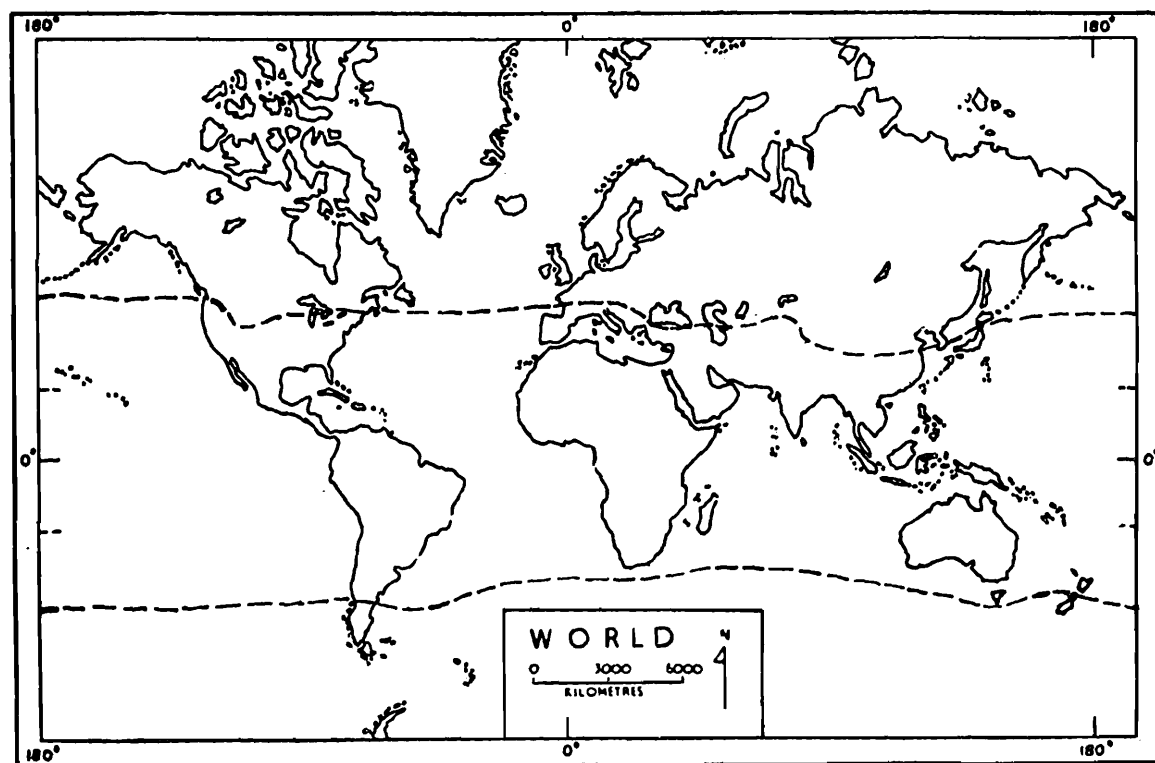

Fig. 63. Map of the world, to show the approximate northern and southern limits, indicated by thick broken lines, of the distribution of termites. (The limits roughly correspond to the mean annual isotherms of 10°C or 50°F.)

dwelling in cold climates), termites have gone up to much northern latitudes (e.g., Hamburg in West Germany, c 53°N). As for altitudes (high altitudes are correlated with low temperatures), several species ascend up to 1,800m above m.s.l., but only a few go higher. The highest altitude is reached by a Himalayan species, *Archotermopsis wroughtoni* (2,700 m, vide Roonwal 1979b).

The present fauna covers that portion of South Asia which is known zoogeographically as the Indian Region. It extends between the approximate latitudes 6°S to 37°N and longitudes 61° to 101°E, and includes six countries below the Himalayas, from Pakistan in the west to Burma in the east (Pl. 5), and the Indian Ocean islands, and covers a total land area of c 5,149,530 sq. km as follows, in which about 300 species are known to occur.

<u>Country</u>	<u>Area (sq. km)</u>
1. Pakistan	803,940
2. India	3,276,373
3. Nepal	141,400
4. Bhutan	41,400
5. Bangladesh	142,776
6. Burma	678,031
7. Sri Lanka	65,610
<b>Total :</b>	<b>5,149,530</b>

This vast landmass contains a great variety of physical features, climate, soil and vegetation, all of which affect termite distribution. At the top there is a broad crown of high mountains, the Himalayas, including the highest peaks in the world. In the peninsular south also there is the high Deccan plateau and several high mountain ranges. Below the crown lie the great Indo-Gangetic Plains whose extreme western part forms the Thar or the Great Indian Desert.

The climate of the region varies considerably from temperate (in the Himalayan areas) to subtropical and tropical. Some parts of northern India and western Pakistan are very cold, even snowbound, in winter (often several degrees below 0°C). The rest of the region can be divided into two

contrasting halves. The northern continental half has cold winters (often near or below the freezing point) and hot, dry summers (temperatures reaching  $50^{\circ}\text{C}$ ). The southern, peninsular half is uniformly hot the year round (Figs. 64 and 65).

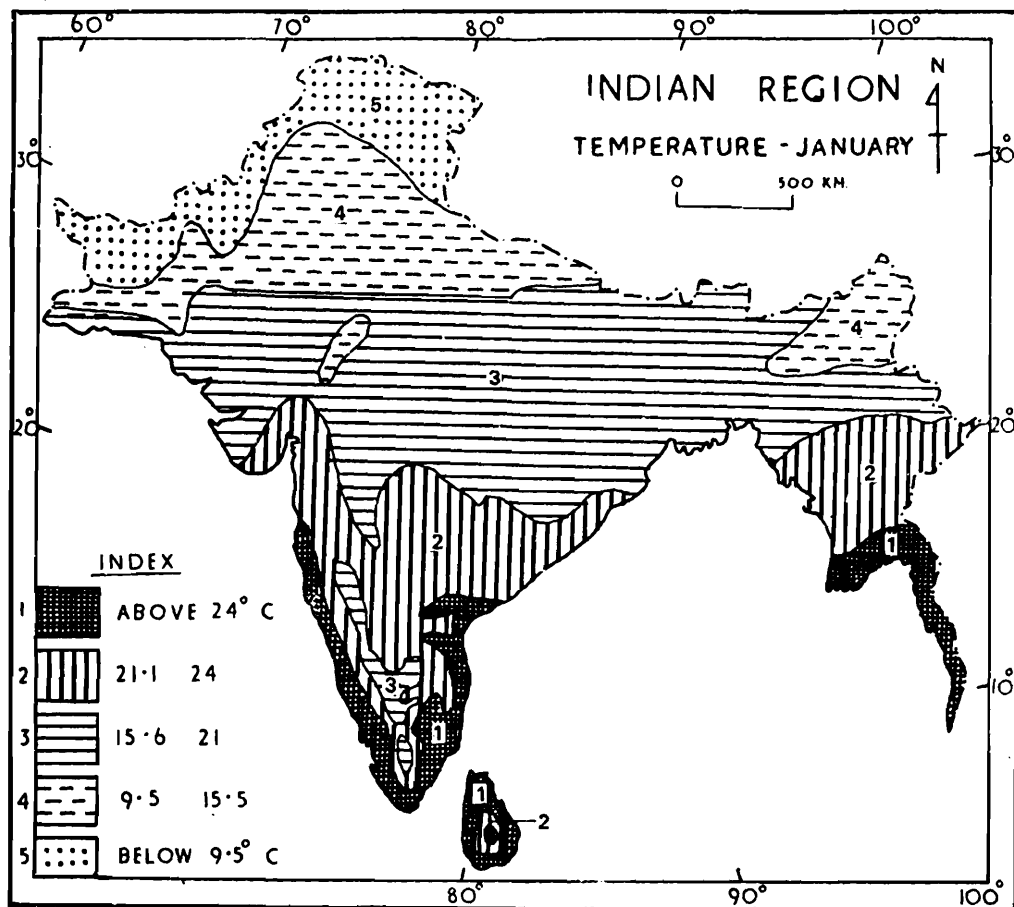

Fig. 64. Indian Region, mean temperatures, January.

The rainfall varies a great deal (Fig. 66) and is largely covered by the summer and winter monsoons. The Thar Desert in the west has less than 5 cm of annual rainfall, while Cherapunji in the east (Meghalaya) has about 1070 cm. The soil varies from yellow, coarse sand in the Thar Desert to clay loam and silt elsewhere; some areas are gravelly.

The natural forest types vary from alpine to dense evergreen, deciduous and scrub, and mangroves occur in the coastal tidal swamps. Altogether, 14 main forest types are recognisable on the mainland, and 6 in Sri Lanka (Ceylon) (Fig. 67). The rest of the land is cultivated, the crops and plantations often becoming the victims of termites.

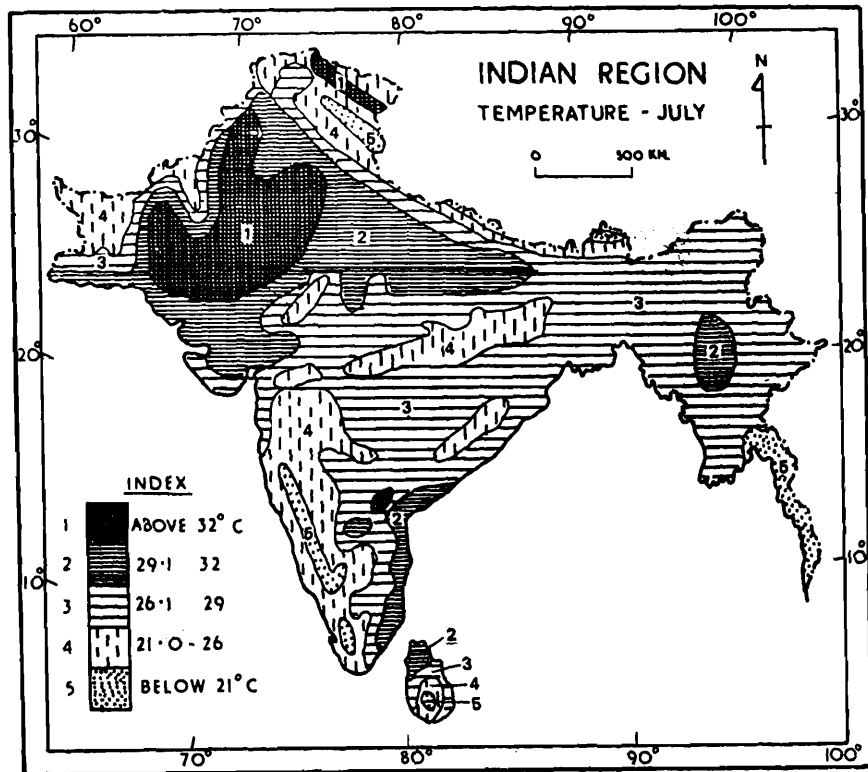

Fig. 65. Indian Region, mean temperatures, July.

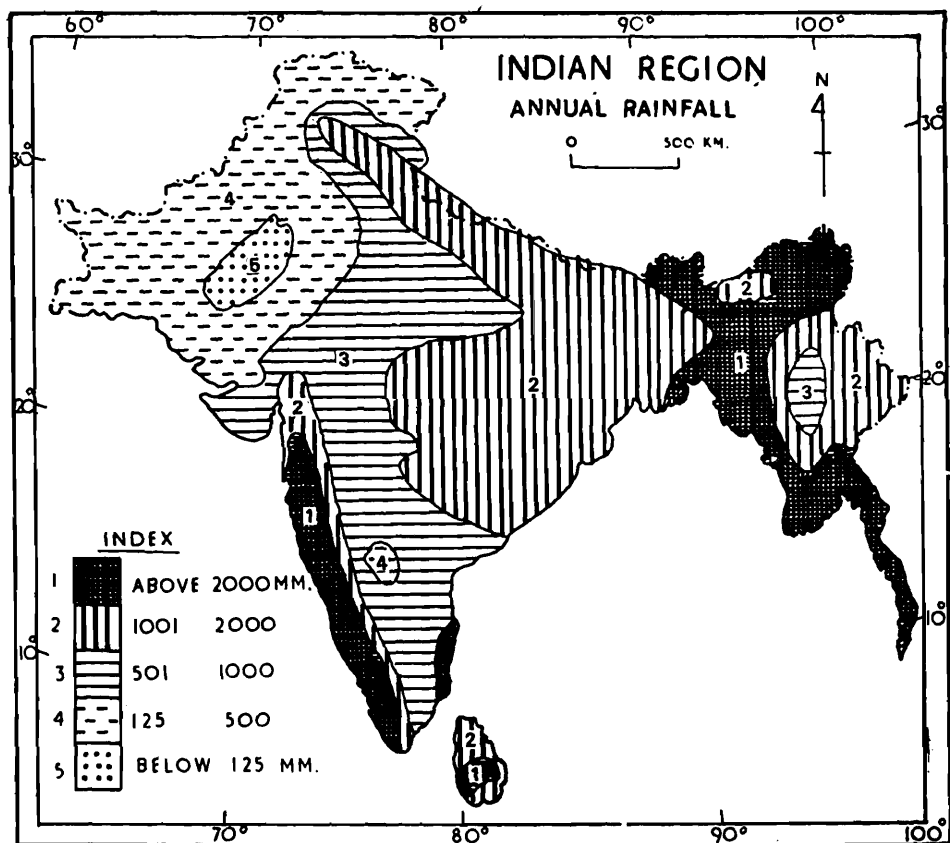

Fig. 66. Indian Region, mean annual rainfall.

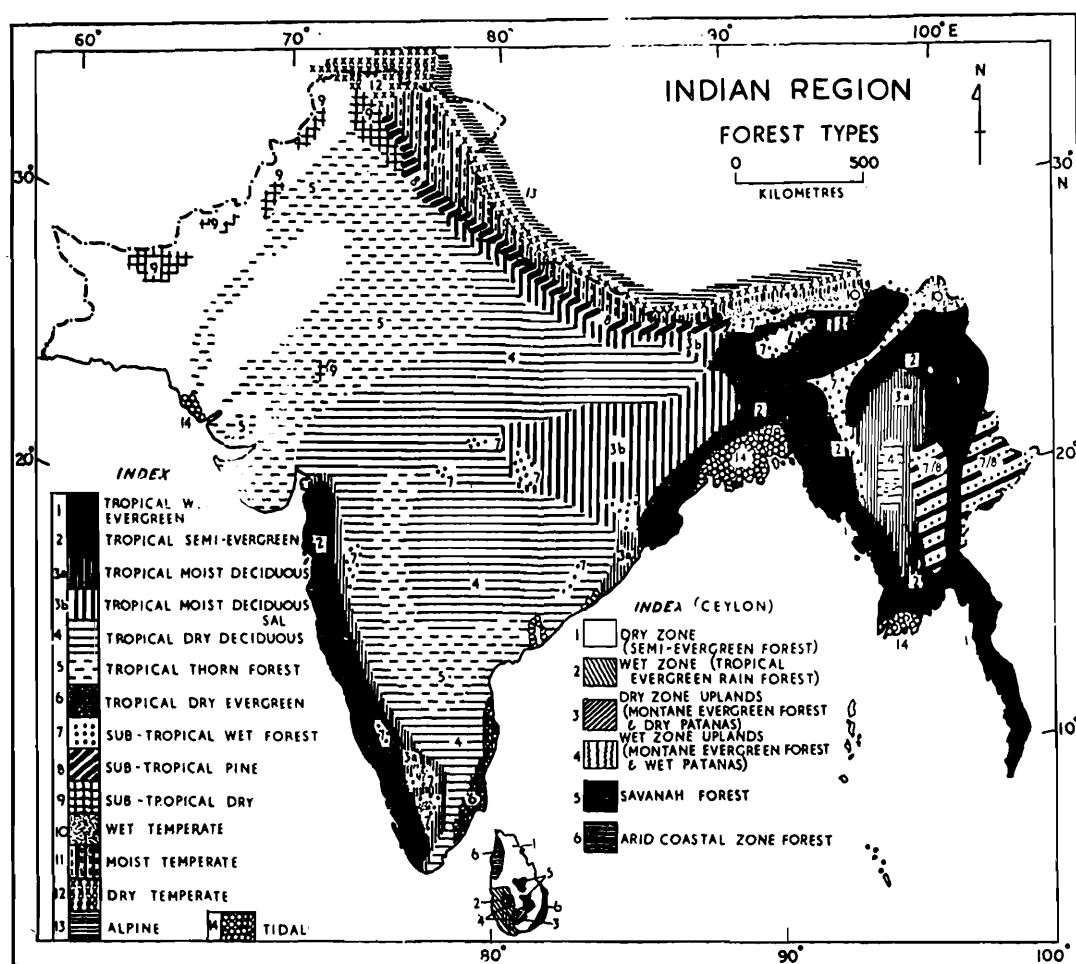

Fig. 67. Indian Region, forest types, Fourteen main types are recognisable on the mainland and 6 in Sri Lanka (Ceylon).

Regional faunas have been studied fairly intensively, especially the following : PAKISTAN : Ahmad (1955, 1962), Akhtar (1974a, b). INDIA: The north-western Himalayas (Chatterjee and Thakur 1967, Thakur 1975c); Rajasthan, including the Thar Desert (Roonwal 1975e, 1976, 1977b, 1982c, 1983a, Roonwal and Bose 1964, 1969, 1978, and Roonwal and Verma 1977); West Bengal (Maiti (1983); the Assam Region (Roonwal and Chhotani 1962a, 1965); Orissa (Bose and Das 1982, 1987); Peninsular India (Roonwal 1978a, Bose 1984) and the Andaman and Nicobar Islands (Roonwal and Bose 1965, 1970a and Bose 1980). BHUTAN Roonwal and Chhotani (1977). BANGLADESH : Akhtar (1975). SRI LANKA (Ceylon): Escherich (1911), Bugnion (1913-1915), Bugnion and Ferriere

(1911), Bugnion and Popoff (1910a, b), John (1925). BURMA Krishna (1965).

These accounts have helped in giving us a fairly clear picture of the distribution of the termite fauna of the Indian Region. On the whole it is evident that there is a greater variety of species, and a higher degree of endemism, in areas with high rainfall and thick forest cover than in the more open and drier ones. Thus, in the dry area of Rajasthan (whose fauna and ecology has been studied more intensively than in any other comparable area of the Indian Region) there are, in a total land areas of about 342,274 sq km, only 32 species and low endemism (only 5 endemic species or 15.6%) (vide Roonwal 1976). In contrast, areas which are very wet and are covered with dense, evergreen forests have a greater variety of species and a higher degree of endemism. Thus, Eastern India (the "Assam Region", area about 269,000 sq km) has over 34 species of which 59% are endemic (Roonwal and Chhotani 1962a, 1965). In the Andaman and Nicobar Islands (area about 8120 sq km) there are over 17 species of which 59% are endemic.

## 2. Zoogeography (Fig. 68-71)

Regional zoogeographies have been studied by several authors, especially the following :

Pakistan (Akhtar 1974b).

India : Assam Region (E. India) (Roonwal and Chhotani 1965); West Bengal (Maiti 1983); Rajasthan (W. India) Roonwal and Bose 1964 Roonwal 1976, 1982c, Roonwal and Verma 1977); Andaman and Nicobar Islands (Roonwal and Bose 1965, 1970a).

Bangladesh (Akhtar 1975).

The zoogeographical composition of the termite fauna of the Indian Region is, as expected, largely Oriental, but there is a massive incursion of the Ethiopian element and a small one of the Palaearctic and even of the Neotropical. A few examples will suffice.

In the Assam Region of eastern India (Roonwal and Chhotani 1965), 3% of the fauna is palaeartic (Chinese elements), 3% Neotropical, and the

rest is Oriental; 59% is endemic. The small Neotropical element (*Anoplotermes shillongensis*) calls for some comment. The *Anoplotermes* and the allied genera (Fig. 68) is almost entirely confined to the Neotropical (South American) and the Ethiopian (Tropical Africa) regions, but a single species, *A. shillongensis*, has been found in the Assam Region in eastern India (Roonwal and Chhotani 1959, 1960b, 1962c). This occurrence of a Neotropical element in the Indian fauna is best explained on the basis of Wegener's Continental Drift Theory in which it is postulated that in the middle geological time, the southern continents formed a single land-mass which split up and gradually drifted apart to form three widely separated masses, viz., South America, Africa and South Asia (Fig. 71). A similar example pertains to genus *Speculitermes* (closely allied to *Anoplotermes*) and the related genus *Ruptitermes* even more strongly, since these genera occur in South America (*Ruptitermes*) and India (*Speculitermes*) but seem to be absent from Africa (Fig. 69).

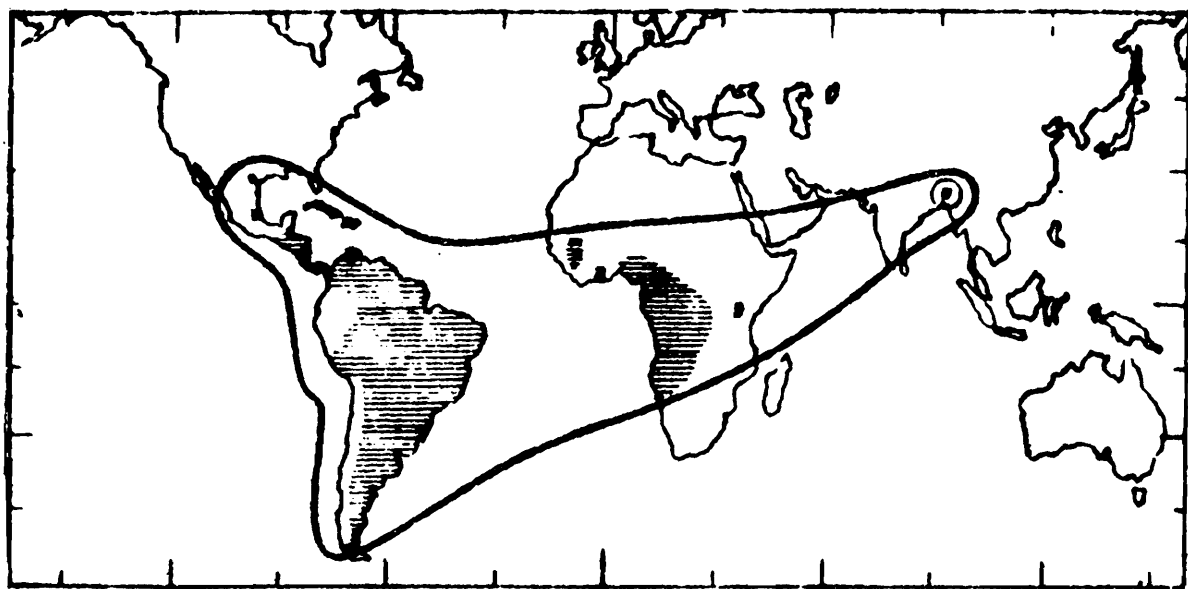

Fig. 68. World distribution of *Anoplotermes* and allied genera (Ex Roonwal, Chhotani and Bose 1962.)

An example of the incursion of an Ethiopian element is the genus *Psammotermes* which is mainly African and has a single species, *P. rajasthanicus*, from western India (Roonwal and Bose, 1960, 1962) (Fig. 70).

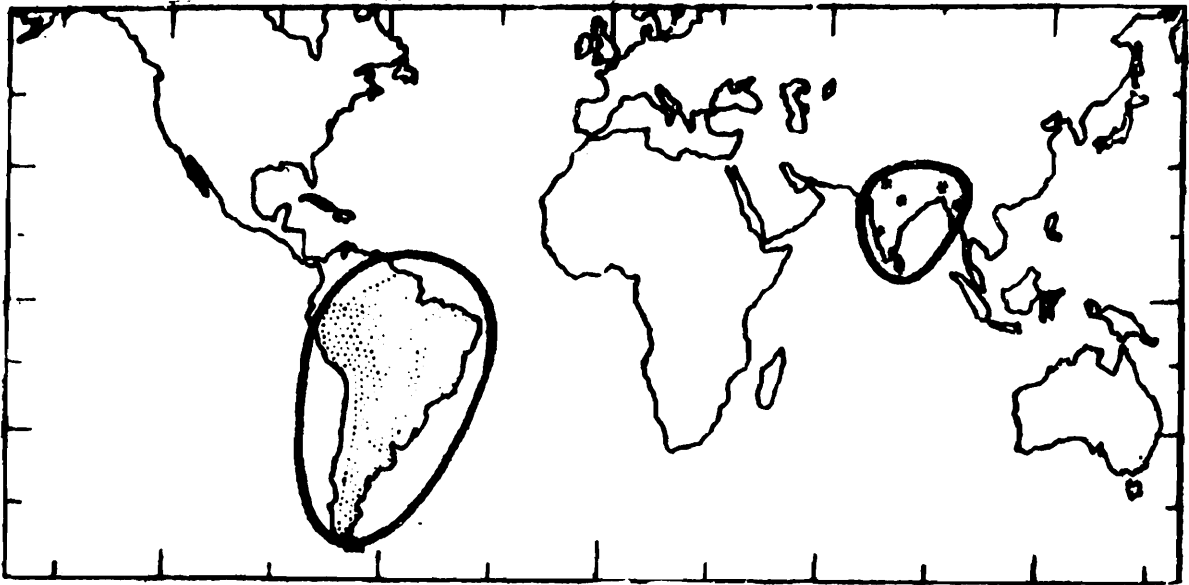

Fig. 69. World distribution of *Speculitermes* (India) and *Ruptitermes* (S. America) (Ex Roonwal, Chhotani and Bose 1962.)

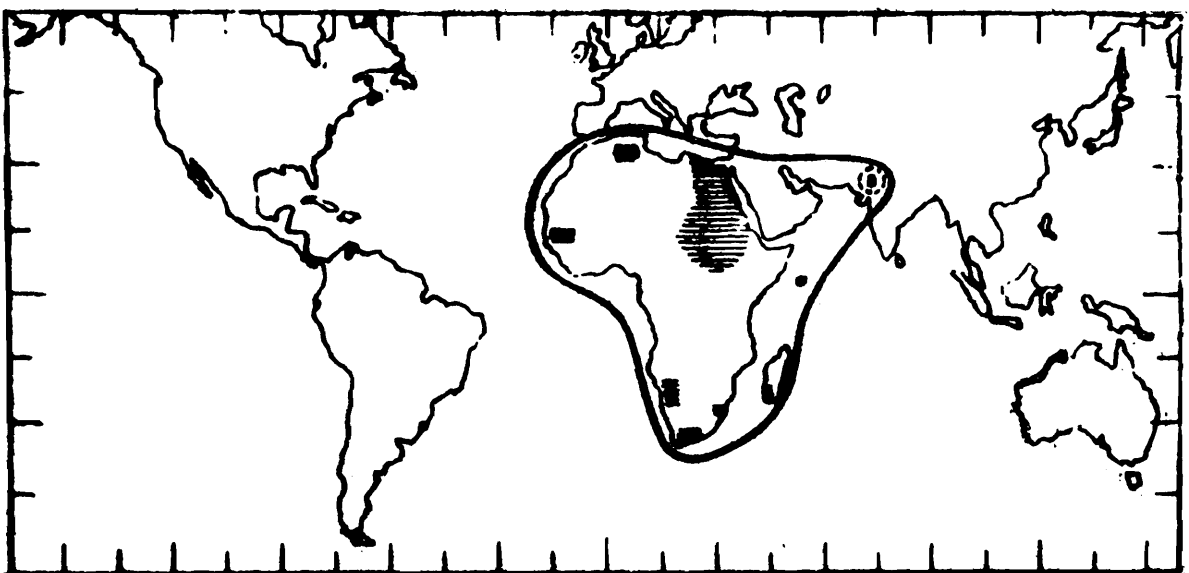

Fig. 70. World distribution of genus *Psammotermes*. (Ex Roonwal, Chhotani and Bose 1962).

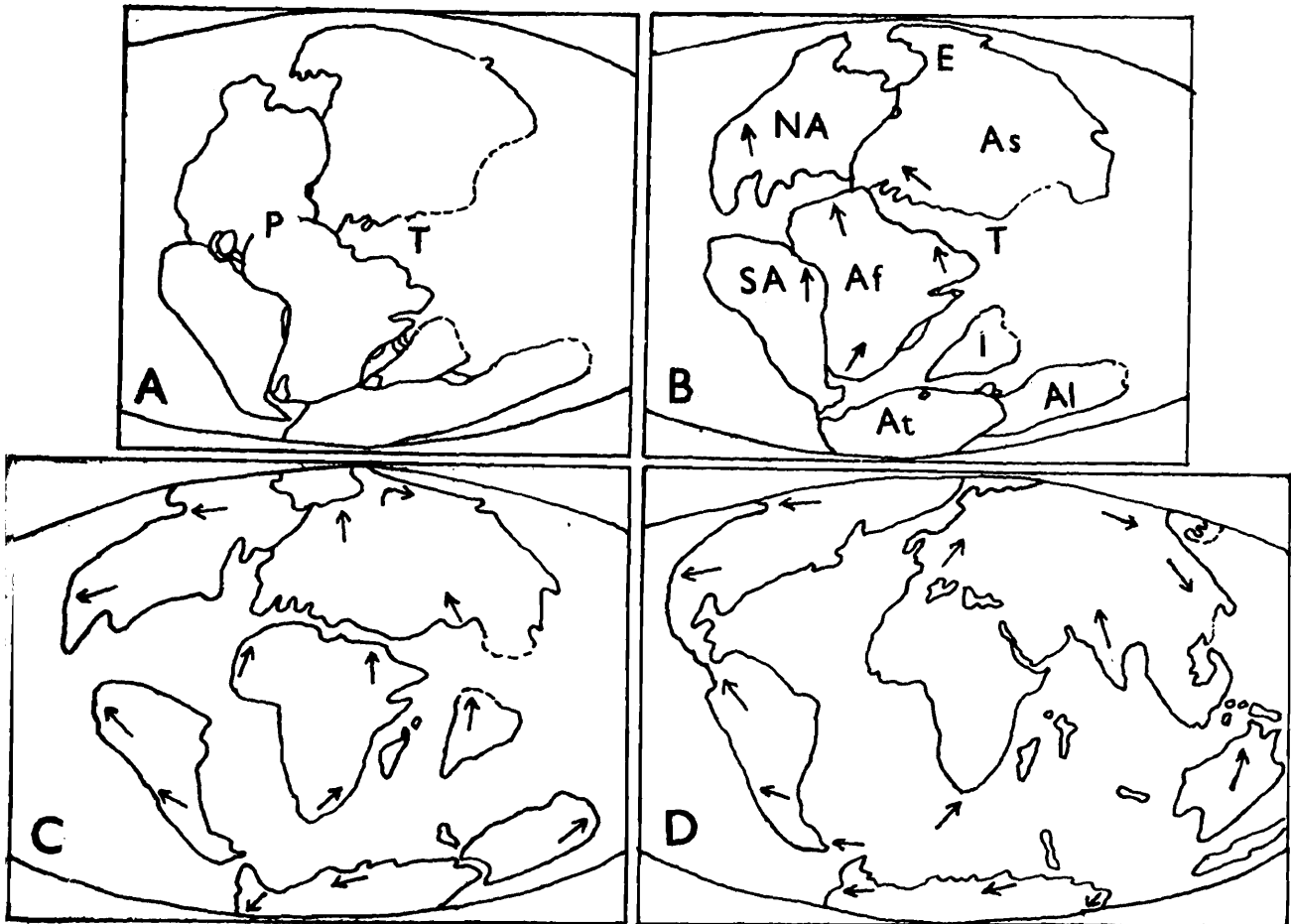

Fig. 71. Drift of continental land masses during the Mesozoic Era, beginning with a single landmass, the Pangaea. To explain the occurrence of forms common between South America, Africa and South Asia. Arrows indicate direction of drift. (A) End of Permian. (B) End of Triassic. Pangaea now separated, by the Tethys Sea, into a northern (Laurasia) and a southern (Gondwana) landmass. (C) End of Cretaceous. South America, Africa and India have been separated from Antarctica. (D) Coenozoic. (Ex various sources.)

Af., Africa; Al, Australia; As, Asia; At, Antarctica; E, Europe, I, India; NA, North America; P, Pangaea; SA, South America; T, Tethys Sea.

'Genus *Anacanthotermes* provides an example of the incursion of the Palaearctic element. It is mainly found in North Africa and Central Asia, but two species enter the Indian Region (Pakistan and western and southern India).

The fauna of the Andaman and Nicobar Islands (with wet, evergreen forests) is wholly Oriental (Roonwal and Bose, 1965, 1970a). Here too, as in the Assam Region, endemism is high, 59 per cent.

The origin of the Rajasthan fauna in Western India (Roonwal and Verma 1977, Roonwal, 1982c) provides a good example of zoogeographically mixed fauna, the percentages of the various elements being as follows: Palaearctic 3, Ethiopian 69, Oriental 16, Neotropical 3, and doubtful 9. The Neotropical element refers to genus *Speculitermes*, vide supra. The high proportion of the Ethiopian element is explained by the fact that the genera concerned are Ethiopian in *origin*, but have *now* (Recent periods) become Oriental and are well established in the Indian Region. Endemism is low, only 16 per cent (cf. Assam and the Andaman and Nicobar Islands, 59 per cent).

In Pakistan (Akhtar 1974b) there is considerable incursion of the Palaearctic element (26%), but the bulk of the fauna is "Oriental" (60%), the mixed elements being only 4% (Oriental, Ethiopian and Papuan) and 10% (Oriental and Palaearctic). The small proportion of the Ethiopian fauna (mixed) is noteworthy and the supposed absence of the Neotropical is also noteworthy but Akhtar evidently considered present-day distributions and not the origins of the concerned genera.

The Bangladesh fauna (Akhtar 1975) is almost entirely Oriental, with only 4% of the fauna being mixed (in fact, cosmopolitan); both Palaearctic and Ethiopian elements are absent.

The neighbouring state of West Bengal (Maiti 1983), is a mixed area, with both tropical as well as temperate zones (the Himalayas and the sub-Himalayas). The fauna is largely Oriental but contains some Palaearctic elements as well (*Reticulitermes*), and endemism is fairly high (31%), though not as high as in the wholly wet-tropical areas like Assam and the Andaman and Nicobar Islands.

PLATE 5

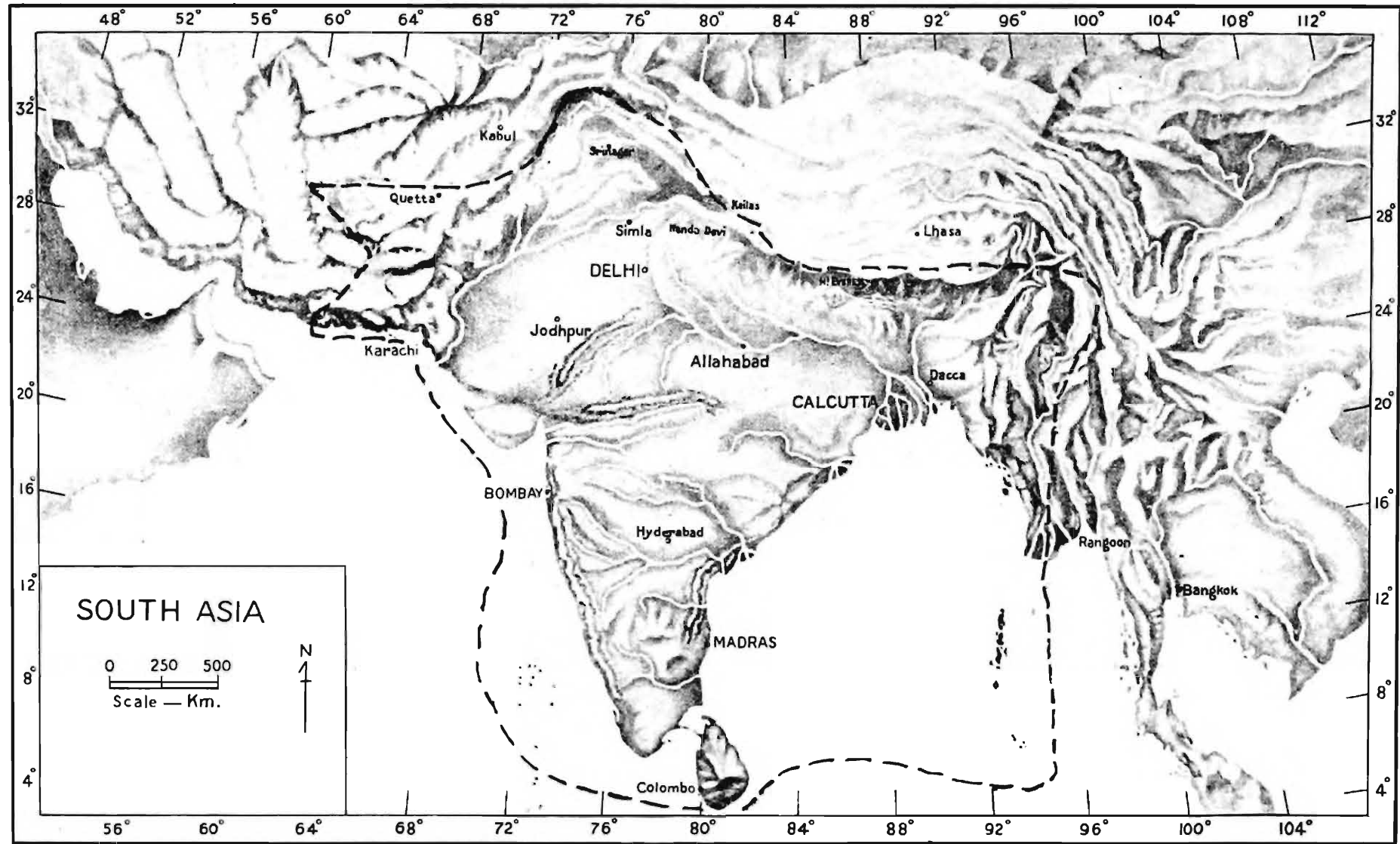

Map of South Asia, to show physical features. The thick broken line indicates the approximate limits of the Indian Region covered by the *Fauna*.

PLATE 6

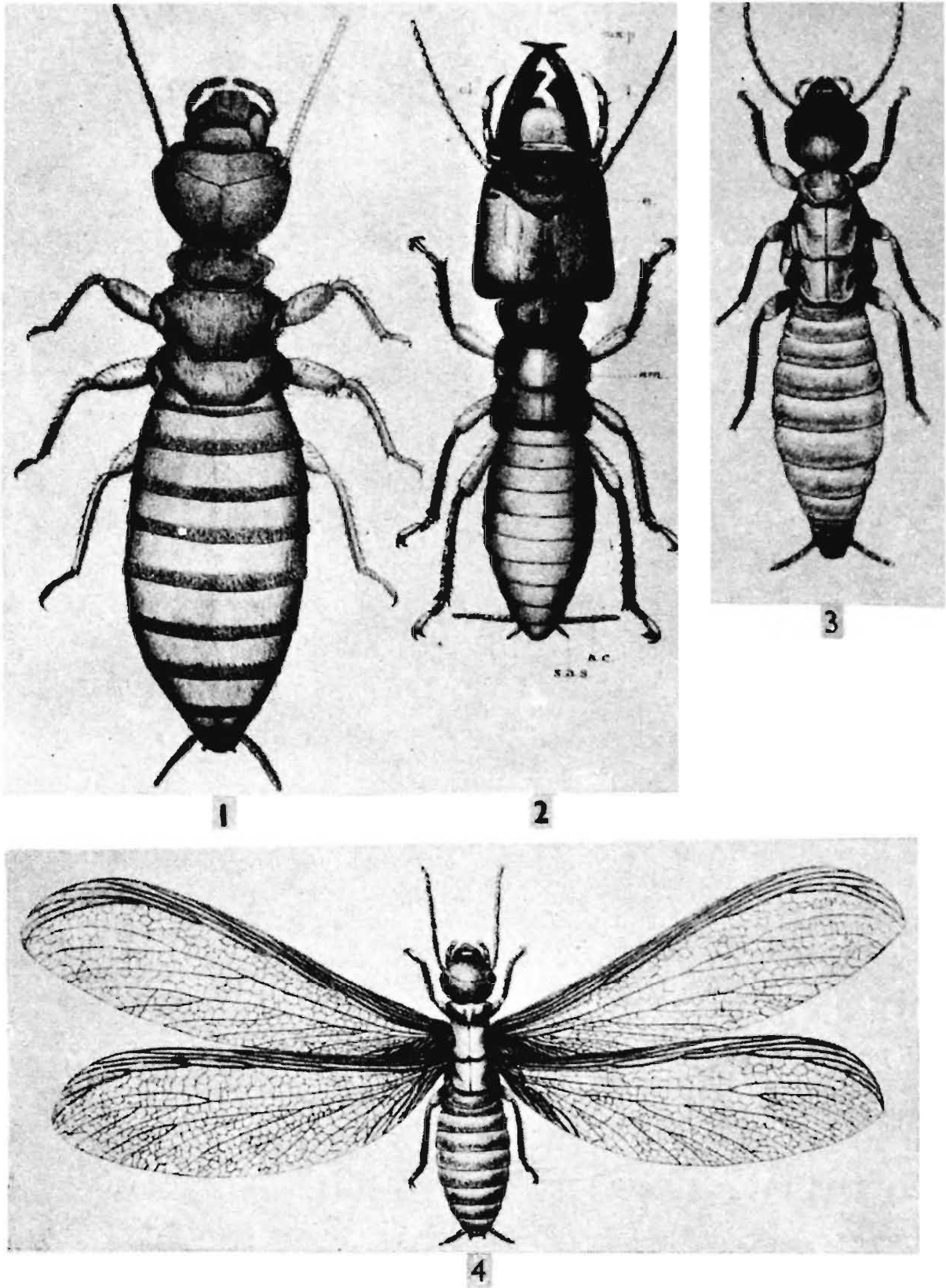

*Archotermopsis wroughtoni*. Kumaon Hills, India (1) Fully formed pseudoworker x 6.6. (2) Fully formed soldier x 4. (3) A queen from a nest x 5. (4) A winged male x 2.6 (After Imms, 1919).

## SYSTEMATIC ACCOUNT

### HISTORY OF TERMITE CLASSIFICATION

#### 1. *History*

As with other animal groups, the history of modern classification of termites begins with Linnaeus in the middle of the 18th century. Roonwal (1962b) has divided this history into four periods, the end of each period being marked by the publication of a major taxonomic work. The First Period ends with the year 1758 which is marked by the publication of the 10th edition the *Systema Naturae* of Linnaeus which is universally accepted by zoologists as the starting point of animal taxonomy and nomenclature. Only three species of true termites were known to Linnaeus who placed them in class Insecta but under two different orders, Neuroptera and Aptera, as follows

*Neuroptera* : Two winged species (no other castes were mentioned) were placed here under the genus *Hemirobius* (pp. 549-551), as follows:

1. *H. testaceus* (p. 550) from America (= modern *Coptotermes testaceus* L., family Rhinotermitidae, subfamily Coptotermitinae).

2. *H. marginalis* (p. 550), from America (= modern *Rhinotermes marginalis* L., family Rhinotermitidae, subfamily Rhinotermitinae).

*Aptera* : Three species (all apterous or wingless) were listed here under the genus *Termes* (pp. 609-610) as follows :

1. *T. fatalis* from "India" (errore = Surinam, South America, vide Snyder, 1949, p. 180). Today also is placed in the same genus (family Termitidae, subfamily Termitinae\*).

2. *T. pulsatorium*, Europe and America.

3. *T. fatidicum*, Europe.

---

\*Roonwal (1962b) placed it under subfamily Macrotermitinae.

The last two species are not termites but probably Psocids or book-lice (vide Snyder, 1949, p. 352).

In the second Period (1759-1858) considerable work on taxonomy and biology was carried out, and it culminated in the publication of Hagen's (1858a) world monograph in which he described all the known species. In the main part of this work he described 98 species, including 14 fossil and 31 new ones. These he ascribed to "Tribus Corrodentia Burmeister" (of the major group Neuroptera), a single family "Termitina Stephens, Burmeister", and 4 genera and a number of subgenera, as follows :

Genus 1. *Calotermes* Hagen (20 species).

Genus 2. *Termopsis* Heer (5 species).

Genus 3. *Hodotermes* Hagen (13 species).

Subgenus *Hodotermes* Hagen.

Subgenus *Porotermes* Hagen.

Subgenus *Stolotermes* Hagen.

Genus 4. *Termes* Linnaeus (60 species).

Subgenus *Termes* "Hagen"

Subgenus *Eutermes* Heer.

*Rhinotermes* (author not mentioned = Hagen).

Thus, during this period, covering a century, 1759-1858, the number of new species described was 95, an average of about one species a year. The main contributors were : Hagen (31 species), Heer (9, mostly fossil), Rambur (9), Walker (7), Smeathman (6), König (4), Kollar (4) and Burmeister (4).

The Third Period (1859-1949) was one of great activity and during it scores of new genera and hundreds of new species were added. Its end was marked by the publication by Snyder (1949) of a world catalogue of termites which listed 1773 species (1710 living, 63 fossil) distributed in 158 genera (141 living, 12 fossil) and 6 families and several subfamilies; the rate of discovery was thus about 18.4 species per year. At the same time extensive work was done on morphology, digestion, symbiotic Protozoa, termitophiles, mound and nest structures, biology, ecology, and control (including wood-preservation methods and the testing of wood for natural

termite resistance). Among the more important of the numerous workers who contributed during this period are : Emerson (the world, but specially South America and Africa), Hill (Australia), Grassé (Africa, and general taxonomy), Holmgren (the world, and general morphology and classification, especially his monumental series of "Termitenstudien"), Light (N. America, the Philippines and China), (Silvestri, the world), Snyder (N. America and the world), Sjöstedt (Africa), and Wasmann (general taxonomy and termitophiles). Snyder's (1949) world catalogue is an indispensable work of reference for taxonomists. The appearance of Hegg's (1922) fine book and Grassé's (1949) comprehensive review may also be mentioned.

After Hagen's (1858a) simple and limited classification, several relatively more extended arrangements by various authorities were proposed, e.g., by Froggatt, Silvestri, Desneux and others which we need not discuss in detail (for a summary, vide Holmgren, 1911c). The most comprehensive classification, however, was given in Holmgren's "Termitenstudien" (1909-1913), based on an extensive study of termite anatomy and the world fauna. In Part 2 of this study (1911c) he gave the following classification, with 4 families, 9 subfamilies, 32 genera and 12 subgenera :

- Fam. 1. Mastotermitidae (1 genus)
- Fam. 2. Protermitidae
  - Subfam. Hodotermitinae (3 genera)
  - Subfam. Stolotermitinae (1 genus)
  - Subfam. Calotermitinae (2 genera, 4 subgenera)
- Fam. 3. Mesotermitidae
  - Subfam. Leucotermitinae (3 genera)
  - Subfam. Coptotermitinae (2 genera)
  - Subfam. Rhinotermitinae (2 genera)
  - Subfam. Serritermitinae (1 genus)
  - Subfam. Serritermitinae (1 genus)
  - Subfam. Termitogetoninae (1 genus)
- Fam. 4. Metatermitidae
  - Subfam. Termitinae (16 genera, 8 subgenera)

With more extensive studies, (the number of known species now rising to nearly 2000), two 'modern' classifications have emerged simultaneously—one by Snyder (1949), the other by Grasse (1949). Both recognise 6 families, but otherwise differ considerably in their content (Table 3). The arrangement of Snyder, with minor changes, is more widely used.

The Fourth Period (1950 onward) is marked by renewed activity following the lull period due to the Second World War (1939-1945) and is marked by numerous publications e.g., from the U.S.A. (the American Museum of Natural History, New York, Emerson and his school), and Kistner from California, termitophiles), the British Museum of Natural History, London (Termite Research Unit, Harris and others), the Forest Research Institute, Dehra Dun and the Zoological Survey of India, Calcutta (Roonwal and co-workers), the Panjab University, Lahore (Ahmad and others), the University of Lovanium, Leopoldville (now Kinsasha in Zaire, formerly Congo)(Bouillon and co-workers), the Commonwealth Scientific and Industrial Research Organisation, Canberra (Gay and others), the Sao Paulo University, Brazil (Araujo), West Germany (Becker in Berlin and Weidner in Hamburg), France (Grasse in Paris and Noirot in Dijon), and from a number of other places.

In the Indian context, the following 'catalogues' need to be mentioned : Catalogue of Indian Isoptera (Rattan Lal and Menon, 1953), Catalogue of the Isoptera Collection at the Forest Research Institute, Dehradun (Roonwal and Pant, 1953) and a revised one (Mathur and Thapa, 1962a). All these catalogues give names and distributions, but some further comment is necessary. The work of Rattan Lal and Menon contains synonymies, references to literature, etc., and would have been valuable but for the fact that it is a mechanical compilation and a single species is sometimes given in two places under different names. The catalogue of Mathur and Thapa is so full of errors that a 9-page *errata* list had to be issued a year later which, however, takes care of some printing errors only, leaving the scientific bloomers untouched. These two works should, therefore, be consulted with caution.

The following classificatory changes have been made in recent years

*New Families :*

(1) Family Indotermitidae Roonwal and Sen-Sarma 1960

Table 3. Classification of the Order Isoptera (according to Snyder, 1949, and Grassé, 1949)

---

After SNYDER, 1949

---

Order Isoptera Brullé

Fam. I. URALOTERMITIDAE\* Zalesky, 1939 (Fossil : Permian)

Fam. II. MASTOTERMITIDAE Silvestri, 1909

Fam. III. KALOTERMITIDAE Enderlein, 1909

[= Calotermitidae, Sjöstedt, 1926]

S.F. 1. Electrotermitinae\* Emerson, 1942 (Fossil : Eocene, Oligocene, Miocene)

S.F. 2. Kalotermitinae Froggatt  
[errore = Holmgren, 1910, 1911]

Fam. IV. HODOTERMITIDAE Snyder, 1925

S.F. 1. Termopsinae Holmgren 1911

S.F. 2. Stolotermitinae Holmgren, 1910, 1911

S.F. 3. Porotermitinae Emerson, 1942

S.F. 4. Hodotermitinae Holmgren, 1911

Fam. V. RHINOTERMITIDAE Light, 1921

S.F. 1. Psammotermitinae Holmgren, 1911

S.F. 2. Heterotermitinae Froggatt, 1896  
[= Leucotermitinae Holmgren, 1911]

S.F. 3. Stylotermitinae Holmgren and Holmgren, 1917

S.F. 4. Coptotermitinae Holmgren, 1910, 1911

S.F. 5. Termitogetoninae Holmgren, 1910, 1911

S.F. 6. Rhinotermitinae Froggatt, 1896

Fam. VI. TERMITIDAE Westwood, 1840

S.F. 1. Serritermitinae Holmgren, 1910, 1911

S.F. 2. Amitermitinae Kemner, 1934

S.F. 3. Termitinae Sjöstedt, 1926  
[= Miro-Capritermes Series, Holmgren, 1912; = S.F. Mirocapritermitinae, Kemner, 1934]

S.F. 4. Macrotermitinae Kemner, 1934

S.F. 5. Nasutitermitinae Hare, 1937

Fam. VII. OF DOUBTFUL POSITION

Foraminitermes—group of Holmgren, 1912 (with a single genus *Foraminitermes* Holmgren, from tropical Africa)

Abbreviations : Fam. = family; S.F. = subfamily.

\*Known as fossil only.

---

After GRASSÉ, 1949

---

Order **Isoptera** Brulle' 1832

Fam. I. MASTOTERMITIDAE Silvestri, 1908 [= 1909]

Fam. II. CALOTERMITIDAE Sjöstedt, 1925 [= 1926]

[= Protermitidae Holmgren, 1909, p.p.]

S.F. 1. Electrotermitinae\* Emerson, 1942

S.F. 2. Calotermitinae Holmgren, 1909

Fam. III. TERMOPSISIDAE Grassé, 1949 (*nec* Karny, 1930)

[= Protermitidae Holmgren 1909, p.p.]

S.F. 1. Termopsinae Holmgren, 1911

S.F. 2. Porotermitinae Emerson, 1942

S.F. 3. Stolotermitinae Holmgren, 1909

Fam. IV. HODOTERMITIDAE Sjöstedt, 1925 [= 1926]

[= Protermitidae Holmgren, 1909, p.p.]

Fam. V. RHINOTERMITIDAE Light, 1921

[= Mesotermitidae Holmgren, 1909]

S.F. 1. Psammotermitinae Holmgren, 1911

S.F. 2. Heterotermitinae Froggatt, 1826 [= 1896]

S.F. 3. Coptotermitinae Holmgren, 1909

S.F. 4. Arrhinotermitinae Sjöstedt, 1925 [= 1926]

S.F. 5. Termitogetoninae Holmgren, 1909

S.F. 6. Rhinotermitinae Froggatt, 1896

S.F. 7. Serritermitinae Holmgren, 1909

Fam. VI. TERMITIDAE Light, 1921

[= Metatermitidae Holmgren, 1909; = Termitidae Banks 1920, p.p.]

S.F. 1. Macrotermitinae Kemner, 1934

S.F. 2. Nasutitermitinae Hare, 1937

S.F. 3. Amitermitinae Kemner, 1934

S.F. 4. Mirocapritermitinae Kemner, 1934

[= *Miro-Capritermes* Series of Holmgren, 1912]

S.F. 5. Microcerotermitinae Holmgren, 1910

[= *Microcerotermes* Series of Holmgren, 1912]

Fam. VII. OF DOUBTFUL POSITION

*Foraminitermes* Holmgren (Tropical Africa)

*Pseudomicrotermes* Holmgren (Tropical Africa).

Roonwal and Sen-Sarma (1960) erected this family to include their new genus and species, *Indotermes maymensis*, from Burma. (The genus *Sinotermes* He and Xia 1981, from China, is a synonym of *Indotermes*.) It is characterised, among other things, by the rarely occurring 3-segmented tarsi. For its phylogeny and taxonomic position, see also Roonwal (1975a). The family, originally described from soldiers, is characterised as follows (Roonwal, 1975a):

**Imago** : Head subround with a pale, subround mid-dorsal spot. Labrum dome-shaped. Postclypeus swollen, divided into two halves by a median longitudinal suture. Eyes and lateral ocelli present. Antennae 15-jointed. Pronotum weakly saddle-shaped. Forewing with strong costa and radius close to each other; subcosta small, joining costa just outside scale; media widely separated, with 3-4 branches; cubitus with 8-11 branches. Hindwing similar to forewing but subcosta absent, media arising from radius and cubitus with 10-12 branches. Wing covered on both sides by a row of minute pointed papillae at the anterior margin and a dense carpet of minute (1-6  $\mu\text{m}$ ), simple, non-asteroid micrasters on the membrane.

**Soldier** : Head and body profusely hairy. Head hypognathous, massive, subsquarish, sides weakly convex; without either a nasute projection or a fontanelle, and with only an indistinct Y-suture. Eyes and ocelli absent. Labrum very small, dome-shaped. Antennae 14-segmented. Mandibles thick and massive, about two-thirds of head-length, with a large swollen plate-like basal area and a small inwardly covered apical area, the two separated by a large, forwardly-pointed tooth on inner margin. Postmentum subrectangular. Pronotum much smaller than head, strongly saddle-shaped. Legs, long, slender; hind tibia slightly swollen. Apical tibial spurs two on each leg (formula 2:2:2). Tarsi 3-segmented. Abdomen long, swollen. Cerci small 2-segmented. Styli absent.

**Worker** : Weakly hairy. Head subcircular; Y-suture present. Labrum broad, dome-shaped. Mandibles with an apical and two marginal teeth; apical and 1st marginal subequal; 2nd marginal small and widely separated from 1st. Antennae 14-segmented. Pronotum strongly saddle-shaped. Legs slender; tarsi 3-segmented.

## (2) Family Stylotermitidae Holmgren and Holmgren :

The subfamily Stylotermitinae Holmgren and Holmgren (1917) (of family Mesotermitidae = Rhinotermitidae), with genus *Stylotermes* H. and

H. (syn. *Sarvaritermes* C. and T.) was raised by Chatterjee and Thakur (1964) to family rank. For further discussion, see Roonwal (1975a). It has a single genus (India and China), with several species.

### (3) Family Serritermitidae Holmgren

The subfamily Serritermitinae of Holmgren (1910, 1911c) was raised to family rank by Emerson (1965, p. 17), and the characters elaborated by Emerson and Krishna (1975). It has a single genus and species, *Serritermes serrifer* (Bates in Hagen), from Brazil.

### *New Subfamilies :*

#### (1) Subfamily Apicotermitinae :

Grassé and Noirot (1954) erected a new subfamily, Apicotermitinae, to accommodate the genus *Apicotermes* and six other genera of the subfamily Termitinae as follows : *Allognathotermes*, *Apicotermes*, *Coxotermes*, *Heimitermes*, *Hoplognathotermes*, *Jugositermes* and *Rostrotermes*. Among other characters, the alimentary canal in Apicotermitinae differs from the rest of the Termitinae; and the new subfamily is characterised by the following combination of characters (Noirot and Noirot-Timothee, 1969): Crop voluminous and asymmetrical; gizzard greatly reduced, practically devoid of chitinous armour; no "mixed segment" in gut; the four Malpighian tubules open into the midgut, each by a small, ampuliform dilatation; first proctodeal segment very short; enteric valve strongly armed on its *external face*, forming six chitinous lips bearing spines which are greatly differentiated; the valve has undergone a complex evolution; the third segment (paunch) not well developed, but the fourth is very long and possesses one or two dilatations.

The soldierless genus *Anoplotermes* is mainly neotropical (S. america), but a few species are also ethiopian (Africa) and a single one oriental (Roonwal and Chhotani, 1959, 1962c, *A. shillongensis*). Sands (1972), who has revised the African species of the genus, splits it into 16 new genera (half of them monotypic), placing them in the Apicotermitinae. In addition, he has abolished the subfamily Amitermitinae, distributing its genera between the Apicotermitinae and the Termitinae. This arrangement seems unsatisfactory because it involves elaborate dissections without offering any good comparable advantage. It is better perhaps to accept the original

Apicotermitinae of Grassé and Noirot (sens. strict.), with its few genera, but that too does not seem to give particular clarity and it is more advisable to follow the original and simpler arrangement.

(2) Subfamily Prorhinotermitinae :

Quennedey and Deligne (1975) have separated the genus *Prorhinotermes* Silvestri from the subfamily Rhinotermitinae (of the family Rhinotermitidae) to form a new subfamily, Prorhinotermitinae. This has been done on the basis of the characters of the frontal gland armature in soldiers, consisting of the frontal gland, its pore (fontanelle) and the associated cephalic structures (frons, clypeus and labrum). The gland in the family Rhinotermitidae is well developed and extends to a large part of the abdomen. In all the genera of the subfamily Rhinotermitinae except *Prorhinotermes* there is a "daubing brush" of hairs, etc. on the labrum for daubing the enemy with the frontal gland secretion. According to Quennedey and Deligne, the new subfamily is characterised as follows :

**Imago** : Head circular to slightly oval. Clypeus moderately swollen. Fontanelle lying in centre of head capsule. Left mandible with the 2nd marginal tooth much larger than the 1st. Pronotum slightly wider than head. In wings media arising from cubitus or fused with it, forewing scale much larger than hindwing scale.

**Soldier** : Head oval, narrowed in front. Fontanelle rather small, situated in front of the middle of head; a frontal groove runs from fontanelle to clypeus. Mandibles well developed, and nondenticulate.

**Worker** : Mandibles as in imago.

## 2. Classification Adopted Here

The following classification of the living forms (Roonwal, 1979b), which reflects the true relationships and takes into account all the more important morphological characters, including wing-microsculpturing, is adopted here, as being adequate and generally satisfactory :

Fam. 1. Mastotermitidae

Fam. 2. Termopsidae

Fam. 3. Hodotermitidae

- Subfam. Stolotermitinae
- Subfam. Porotermitinae
- Subfam. Hodotermitinae
- Fam. 4. Kalotermitidae
- Fam. 5. Stylotermitidae
- Fam. 6. Rhinotermitidae
  - Subfam. Psammotermitinae
  - Subfam. Coptotermitinae
  - Subfam. Termitogetoninae
  - Subfam. Rhinotermitinae
  - Subfam. Heterotermitinae
- Fam. 7. Serritermitidae
- Fam. 8. Indotermitidae
- Fam. 9. Termitidae
  - Subfam. Amitermitinae
  - Subfam. Termitinae
  - Subfam. Macrotermitinae
  - Subfam. Nasutitermitinae

## DIAGNOSTIC CHARACTERS OF THE LIVING FAMILIES OF TERMITES

### Family 1. MASTOTERMITIDAE Desneux

(Desneux 1904b, subfamily. Raised to family status by Silvestri 1909.  
Emerson 1965, review.)

Hindwing with a large anal lobe. Basal scale of forewing large, covering the smaller hindwing scale. Wing surfaces covered densely (c 7000-9000/mm<sup>2</sup>) with microscopic, finger-shaped papillae at the margins and minute, rounded pimpules all over (Roonwal, Verma and Thakur 1979a, Roonwal 1983c). Most wing veins greatly branched. Tarsi with 5 segments. Tibial spines and spurs covered on inner side with numerous minute, cuticular papillae (Roonwal 1972a, 1974, 1983b). Fontanelle absent. Ocelli present. Antennae long and filamentous, with 29-32 segments. Mandibles with an apical and two marginal teeth on both left and right mandibles. Pronotum flat, wider than head. Female genitalia

complete, with all three ovipositor valves present. Cerci 5 segmented. No true worker caste present, only pseudoworkers. Eggs laid in a packet (ootheca).

A primitive, relict family with a single living genus and species, *Mastotermes darwiniensis* (Australia) and several fossil genera (widespread).

**Family 2. TERMOPSISIDAE Holmgren**  
(Dampwood termites)

(Holmgren 1911c, subfamily. Raised to family status by Grassé 1949.)

Hindwing without an anal lobe. Forewing scale large. Only microscopic papillae present on wing surfaces; no other types of microsculpturing (Roonwal, Verma and Thakur 1979a, Roonwal 1981a, 1983c). Wings with a reticulum. Tarsi imperfectly 5-segmented (4 when seen from above, 5 from below). In some species (*Archotermopsis wroughtoni*) the tibial spines and spurs laterally bear many lamellar or scaly, microscopic, cuticular papillae (Roonwal and Bose 1970b, Roonwal 1983b). Fontanelle absent. Ocelli present or absent. Mandibles with an apical and 2 to 3 marginal teeth. Antennae long, with many segments, 21-27. Pronotum flat, narrower than head. Cerci long and filamentous, with 4-8 segments. No true worker caste present, only pseudoworkers.

A small, primitive family with hardly half a dozen species. Includes three genera. *Archotermopsis*, *Hodotermopsis* and *Zootermopsis*. Some authors include here the hodotermitid subfamilies Porotermitinae and Stolotermitinae, without justification. Both are more advanced in wing microsculpturing and in other respects. Porotermitinae has both papillae and pimpules on wings, and Stolotermitinae has papillae as well as complex micrasters (Roonwal, Verma and Thakur 1979a, Roonwal, 1983b).

**Family 3. HODOTERMITIDAE Snyder**  
(Harvester termites)

(Snyder 1925, Sjöstedt 1926, Emerson, 1967, 1968.)

Includes the living subfamilies Porotermitinae, Hodotermitinae and Stolotermitinae; also a fossil family Cretatermitinae.

Hindwing without an anal lobe. Forewing scale small. Wing surfaces covered densely with a microsculpturing of either papillae and pimpules or

papillae and micrasters. Wing veins well developed; wings reticulated. Tarsi 4-segmented. Antennae long and filamentous, with 23-32 segments. Fontanelle and ocelli absent. All castes with compound eyes. Mandibles with an apical and generally 3 marginal teeth (4 in Porotermitinae) on the left mandible, and an apical and 2 marginals on the right (a small subsidiary tooth sometimes present in front of the first). Pronotum slightly saddle-shaped. Cerci short, with 1-5 segments. True worker caste present.

A small family with about 25 subterranean species. With 5 living genera: *Porotermes*, *Hodotermes*, *Microhodotermes*, *Anacanthotermes* and *Stolotermes*.

#### Family 4. KALOTERMITIDAE Froggatt

[Sometimes spelt as Calotermitidae]

(Drywood termites)

(Froggatt 1896, subfamily. Raised to family by Enderlein 1909, Calotermitidae. Banks 1919, Sjöstedt 1925, Krishna 1961. Emerson 1969, fossils.)

Hindwing without an anal lobe. Forewing scale large, overlapping hindwing scale. Wing surfaces covered densely with microscopic papillae, pimples, and often also with somewhat larger tubercles (Roonwal and Rathore 1978, Roonwal 1981a, 1983b, Roonwal and Verma 1983). Wing veins well developed. Tarsi 4-segmented. Fontanelle absent. Ocelli generally present. Antennae with 11-21 segments. Mandibles with an apical and two marginal teeth on the left mandible (three in some) and two on the right. Pronotum flat, generally broader than head. Cerci short, with 2 segments. No true workers present, only pseudoworkers.

A large, cosmopolitan family with some 25 genera and over 250 living species. Also several fossil genera and species. Representative genera : *Postelectrotermes*, *Kalotermes*, *Neotermes*, *Bifiditermes*, *Glyptotermes*, *Cryptotermes*, *Incisitermes*.

#### Family 5. STYLOTERMITIDAE Holmgren & Holmgren

(Holmgren and Holmgren 1917, subfamily. Raised to family status by Chatterjee and Thakur 1964; for phylogeny, etc., vide Roonwal 1975a. Regarded by some authors as a subfamily of the family Rhinotermitidae.)

Hindwing without an anal lobe. Forewing scale large. Wing surfaces covered with a microsculpturing composed of papillae (on margins),

arrowheads and pimpules; no micrasters. Wings reticulated. Tarsi 3-segmented in all castes. Fontanelle and ocelli present, small. Mandibles with an apical and 3 marginal teeth on the left mandible and 2 on the right with a small "subsidiary" tooth on the latter. Antennae with 16-22 segments. Pronotum flat, narrower than head. Cerci short, 2 segmented. (Roonwal 1975a.)

A small, primitive family with a single living genus, *Stylotermes* (syns. *Sarvaritermes* and *Operculitermes*) and about 30 species. Oriental and Palaeartic (India and China). Also a fossil genus, *Parastylotermes* (N. Europe and N. America).

#### Family 6. RHINOTERMITIDAE Froggatt)

(Froggatt 1896, subfamily. Raised to family status by Light 1921b, Emerson 1971, fossils and general discussion.)

Includes the subfamilies Psammotermitinae, Rhinotermitinae, Heterotermitinae, Coptotermitinae and Termitogetoninae; some authors also recognise a sixth subfamily, Arrhinotermitinae (*Arrhinotermes*) which is not valid and is here included in the Rhinotermitinae.

Hindwing without an anal lobe. Forewing scale generally large. Wings often reticulated and either almost without hairs or heavily hirsute. Wing surfaces covered with 5 types of microsculptures, viz., papillae, arrowheads, tubercles, pimpules and micrasters, in various combinations, the more primitive genera lacking the micrasters (Roonwal, Verma and Thakur 1979b, Roonwal 1983b, c). Tarsi 4-segmented. Fontanelle and ocelli present. Mandibles with an apical and 3 marginal teeth, as in the Stylotermitidae. Pronotum flat. Cerci short, 2-segmented. True worker caste present.

A fairly large, complex assemblage of generally subterranean termites; with some 14 living genera and about 100 species. Representative genera: *Psammotermes*, *Heterotermes*, *Reticulitermes*, *Coptotermes*, *Termitogeton*, *Schedorhinotermes*, *Prorhinotermes*.

#### Family 7. SERRITERMITIDAE Holmgren

(Holmgren 1911c, subfamily. Raised to family status by Emerson 1965, p. 173; Characters elaborated by Emerson and Krishna 1975. Variouslly placed in families Kalotermitidae, Rhinotermitidae and Termitidae.)

Hindwing without an anal lobe. Forewing scale large. Wing microsculpturing consisting only of papillae and arrowheads (Roonwal and Rathore 1985). Wings reticulated. Tarsi 4-segmented. Fontanelle and ocelli present. Mandibles advanced, with an apical tooth and a single marginal tooth widely separated from apical by a deeply concave margin. Antennae with 13-14 segments. Pronotum flat, slightly narrower than head. Cerci short, 2-segmented.

A small South American family with a single living genus and species, *Serritermes serrifer*.

#### Family 8. INDOTERMITIDAE Roonwal & Sen-Sarma

(Roonwal and Sen-Sarma 1960. For phylogeny, etc. vide Roonwal 1975a. Some authors treat it as a part of the subfamily Amitermitinae of family Termitidae.)

Hindwing without an anal lobe. Forewing scale large. Media widely separated from radius. Wing microsculpturing consisting of minute, pointed papillae at the anterior margin and small simple non-asteroid micrasters on the membrane. Tarsi 3-segmented in all castes. Head and body densely pilose. Fontanelle and ocelli present. Mandibles with an apical and two marginal teeth, the 2nd marginal small. Antennae with 15 segments. Pronotum slightly saddle-shaped, slightly narrower than head. Cerci short, probably with 2 segments. (Roonwal and Sen-Sarma 1960, Roonwal 1975a, He and Xia 1981.)

A small family with a single genus *Indotermes* (syn. *Sinotermes*), and some 10 species. Oriental (India to S. China.)

#### Family 9. TERMITIDAE Westwood

(Westwood 1840, Banks 1919, Light 1921b).

Includes the subfamilies Amitermitinae, Termitinae, Nasutitermitinae and Macrotermitinae. Some authors separate a few genera into a fifth subfamily, Apicotermitinae.

Hindwing without an anal lobe. Forewing scale small. Wing surfaces covered densely with several types of microsculptures in various combinations, e.g., papillae (universal), arrowheads (rare), spearheads (rare), pimpules (rare), micrasters (common), microsetae (rare) and rods (in some)

(vide Roonwal, 1983b, c). Wing venation reduced; wings either not reticulated or with only a weak reticulum. Tarsi 4-segmented. Fontanelle and ocelli present. Antennae not long. Mandibles with an apical and two marginal teeth. Pronotum flat (imagoes). Cerci short, with 1-2 segments.

A large family with over 125 genera, comprising nearly two-thirds of all the known species of termites. Some representative genera are:

*Amitermitinae* *Eurytermes*, *Anoplotermes*, *Speculitermes*, *Euhamitermes*, *Amitermes*, *Globitermes*, *Eremotermes*, *Microcerotermes*.

*Termitinae* *Apicotermes*, *Megagnathotermes*, *Cubitermes*, *Tuberculitermes*, *Angulitermes*, *Termes*, *Procapritermes*, *Dicuspiditermes*, *Capritermes*.

*Nasutitermitinae* *Syntermes*, *Cornitermes*, *Nasutitermes*, *Bulbitermes*, *Grallatotermes*, *Hospitalitermes*, *Trinervitermes*, *Subulitermes*.

*Macrotermitinae* : *Protermes*, *Macrotermes*, *Odontotermes*, *Microtermes*.

## KEYS FOR THE IDENTIFICATION OF LIVING TERMITE FAMILIES

The following keys are largely based on Roonwal (1979b); they are artificial, not phylogenetic.

### 1. Key to Imagoes

Winged imagoes are believed to be present in all species, but in several cases they have not yet been described.

- 1(2). Hindwing with an anal lobe. Wing microsculpturing consisting of only papillae and pimpules. Tarsi with 5 segments..... 1. **Mastotermitidae**
- 2(1). Hindwing without an anal lobe. Wing microsculpturing of various types. Tarsi with fewer than 5 segments (usually 3-4).
- 3(6). Ocelli generally absent; when present, only as minute spots. Cerci long, with 3-8 segments.
- 4(5). Antennae moderately long, with 13-19 segments. Wing microsculpturing consisting of only papillae. Tarsi imperfectly 5-jointed (4 when seen from above, 5 from below). ..... 2. **Termopsidae**
- 5(4). Antennae very long and filamentous, with 24-32 segments. Wing microsculpturing consisting, besides papillae, of either pimpules (*Porotermitinae* and *Hodotermitinae*) or micrasters (*Stolotermitinae*)..... 3. **Hodotermitidae**

(Includes the subfamilies Porotermitinae, Hodotermitinae and Stolotermitinae only )

- 6(3). Ocelli clearly present, Cerci short, with 1-2 segments.
- 7(8). Fontanelle absent. Tarsi always 4-jointed. [Pronotum flat, without lateral lobes. True worker caste absent (only immature forms or pseudoworkers present and perform the functions of workers). Wing microsculpturing consisting, besides papillae, of only pimpules or both pimpules and tubercles.]..... **4. Kalotermitidae**
- 8(7). Fontanelle present. Tarsi with either 3 or 4 segments.
- 9(14). Tarsi with 4 segments
- 10(11). Mandibles unique, with greatly attenuated teeth (with an apical and a single marginal); the apical widely separated from the marginal by a long, concave margin. [Wing microsculpturing consisting only of papillae and arrowheads; wing membrane reticulate.]..... **5. Serritermitidae**
- 11(10). Mandibles with more than one well developed marginal teeth....
- 12(13). Basal scale of forewing large (except in the subfamily Psammotermitinae), covering the hindwing scale at least partly. Pronotum flat. Wing microsculpturing consisting, besides papillae, of either arrowheads only, or pimpules only, or micrasters only, or pimpules and micrasters, or none at all; membrane generally reticulate ..... **6. Rhinotermitidae**  
(includes the subfamilies Psammotermitinae, Rhinotermitinae, Heterotermitinae, Coptotermitinae and Termitogetoninae.)
- 13(12). Basal scale of forewing small, not covering the hindwing scale. Pronotum slightly saddle-shaped. Wing microsculpturing consisting, besides papillae, of micrasters only (with or without either arrowheads or pimpules), or of any one of either spearheads, pimpules, microsetae or rods; wing membrane not reticulate..... **7. Termitidae**  
(Includes the subfamilies Amitermitinae, Termitinae, Nasutitermitinae and Macrotermitinae.)
- 14(9). Tarsi with 3 segments
- 15(16). Pronotum flat. Wings with the media vein usually unbranched, rarely bifurcated. Wing microsculpturing consisting of papillae, pimpules and arrowheads. .... **8. Stylotermitidae**
- 16(5). Pronotum slightly saddle-shaped. Wings with the media vein having several branches. Wing microsculpturing consisting of minute papillae and simple non asteroid micrasters,..... **9. Indotermitidae**

## 2. Key to Soldiers

Soldiers are often dimorphic, even polymorphic. The soldier caste is absent in a few genera (e.g. *Anoplotermes*, etc.) and rare in a few others (e.g., *Speculitermes*).

- 1(2). Tarsi with 5 segments. Head broad and somewhat round. Mandibles shorter than head-length, and with a single tooth..... 1. **Mastotermitidae**
- 2(1). Tarsi with fewer than 5 segments (usually 3 or 4)
- 3(14). Tarsi with 4 segments (or with an imperfect 5th segment when seen from below)
- 4(7). Compound eyes present and are pigmented. Cerci fairly long.
- 5(6). Pronotum flat. Tarsi either 4-segmented or imperfectly 5-segmented. Head long, with nearly parallel sides. Cerci long, with 4-8 segments ..... 2. **Termopsidae**
- 6(5). Pronotum slightly saddle-shaped. Tarsi 4-segmented. Head sub-round or oval. Cerci shorter, with 2-5 segments..... 3. **Hodotermitidae**  
(Includes the subfamilies Porotermitinae, Hodotermitinae and Stolotermitinae.)
- 7(4). Compound eyes usually absent (if present, are unpigmented). Cerci very short
- 8(9). Fontanelle absent..... 4. **Kalotermitidae**
- 9(8). Fontanelle present
- 10(13). Pronotum flat
- 11(12). Mandibles without serrations on inner margin, or at most with a few at base; much shorter than head..... 5. **Rhinotermitidae**  
(Includes the subfamilies Psammotermitinae, Rhinotermitinae, Heterotermitinae Coptotermitinae and Termitogetoninae.)
- 12(11). Mandibles with well developed serrations on entire inner margin; subequal to or longer than head..... 6. **Serritermitidae**
- 13(10). Pronotum saddle-shaped..... 7. **Termitidae**  
(Includes the subfamilies Amitermitinae, Termitinae, Nasutitermitinae and Macrotermitinae )
- 14(3). Tarsi with 3 segments
- 15(16). Pronotum flat ..... 8. **Stylotermitidae**
- 16(15). Pronotum strongly saddle-shaped..... 9. **Indotermitidae**

### 3. Key to Workers and Pseudoworkers

Workers and pseudoworkers provide but few distinguishing characters for separation and are difficult to identify with certainty. They are sometimes dimorphic.

- 1(6). True worker caste absent, the older nymphs (with the body soft and whitish) performing that function and being then termed pseudoworkers (pseudergates)
- 2(3). Right mandible with a subsidiary tooth at front base of first marginal tooth..... 1. **Termopsidae**
- 3(2). Right mandible without a subsidiary tooth at front base of first marginal tooth.
- 4(5). Tarsi 5-jointed ..... 2. **Mastotermitidae**
- 5(4). Tarsi 4-jointed..... 3. **Kalotermitidae**
- 6(1). True worker caste present. Workers well chitinised (head usually brown to dark brown)
- 7(8). Mandibles with dentition on inner margin greatly reduced, with the sole marginal tooth widely separated from the apical by a long, incurved margin..... 4. **Serritermitidae**
- 8(7). Mandibles with well developed dentition; an apical and 2 to 4 marginal teeth present.
- 9(12). Tarsi 3-jointed
- 10(11). Mid-dorsal spot on head present. Pronotum strongly saddle-shaped ..... 5. **Indotermitidae**
- 11(10). Mid-dorsal spot on head absent. Pronotum flat..... 6. **Stylotermitidae**
- 12(9). Tarsi 4-jointed.
- 13(14). Antennae long and filamentous (with 24 to 35 segments)..... 7. **Hodotermitidae**
- 14(13). Antennae short (with 12 to 18 segments)
- 15(16). Pronotum flat..... 8. **Rhinotermitidae**
- 16(15). Pronotum saddle-shaped..... 9. **Termitidae**

### DESCRIPTIONS OF FAMILIES, GENERA AND SPECIES

We may now take up the following seven families which occur in the Indian Region :

- Fam. I. **Termopsidae**  
 Fam. II. **Hodotermitidae**  
 Fam. III. **Kalotermitidae**  
 Fam. IV **Rhinotermitidae**  
 Fam. V. **Stylotermitidae**  
 Fam. VI. **Indotermitidae**  
 Fam. VII. **Termitidae**

## Family I. TERMOPSIDAE Holmgren

Some authors, e.g., Grassé (1949), Weidner (1970) and others include here three subfamilies, viz., Termopsinae, Porotermitinae and Stolotermitinae. We assign the last two to the family Hodotermitidae.

## 1. Tribus Termopsis :

1904. Desneux, *Gen. Insectorum*, Fasc. 25, *Isoptera*, Fam. *Termitidae*: 12.

## 2. Subfam. Termopsinae :

1911. Holmgren, *K. Sv. Vet. Akad. Handl.*, 46(6): 34-35.

1933. Emerson, *Calif. Univ. Publ. (Ent.)*, 6(6): 165, 167.

1949. Snyder. *Smiths. misc. Colls.*, 112: 55, 360.

## 3. Fam. Termopsidae

1949. Grassé (nec. Karny 1930), *Traite d. Zool.*, Pt. 9 (*Insecta*): 531.

1970. Roonwal, in *Biol. Termites*, (Eds. Krishna and Weesner), Vol. 2: 328-330.

1970. Weidner, *Handb. d. Zool.*, 4, (2) 2/14 (*Isoptera*): 16-19.

Type genus *Termopsis* Heer. Fossil. Eocene, Miocene, Oligocene. Europe

1. *Characters of Family Termopsidae*  
(excluding Porotermitinae and Stolotermitinae)

*Imago* : Head large, flat. Eyes kidney-shaped. Ocelli present or absent, small. Head sutures clear. Fontanelle absent. Antennae long, filamentous, with 21-27 segments. Anteclypeus large; postclypeus small. Labrum more or less tongue-shaped. Left mandible with 3 marginal teeth; right with 2 marginals and a small subsidiary tooth in front of first marginal. Pronotum, flat, small, narrower than head. Wings densely covered near margins with microscopic thorny to subcrescentic papillae. Wings long, with a transparent membrane, having a fine, irregular reticulum of cross-veins besides the usual veins; radius complex, well developed. Forewing: Scale large; costa strong; subcosta small; radius complex, well developed, with 2 main branches; radial sector with several branches; media weak, arising from radial sector, and with several branches; cubitus with several branches; anal absent or vestigial. Hindwing: Scale small; veins generally as in forewing; media arising from radial sector outside scale; cubitus with numerous

branches; anal vestigial; a rudimentary postanal field present. Tarsi imperfectly 5-segmented (4 above, 5 below); arolium present between claws. Tibial apical spur formula variable, 4: 3-4: 2; spurs and larger tibial spines sometimes (*Archotermopsis*) bearing masses of microscopic, cuticular papillae on margins. Cerci long, with 4-8 segments; styli longish, one-segmented, present in male.

*Soldier* : Head flat; mandibles strong, only slightly shorter than head; with several strong teeth. Eyes small, finely faceted. Ocelli present (minute) or absent. Antennae long, with 19-27 segments. Pronotum flat, narrower than head. Meso- and metapleura sometimes (*Archotermopsis*) with lateral expansions. Tarsi imperfectly 5-segmented, as in imago. Apical tibial spur formula variable, 3-4 : 2-4 : 2; margins of spurs sometimes (*Archotermopsis*) bearing numerous microscopic papillae; arolium absent. Cerci long, with 6-7 segments. Styli in both sexes; longish, one-jointed.

*Pseudoworker* : No true worker caste present; only immature forms (pseudoworkers) functioning as workers. Head large, rounded. Eyes present, small. Ocelli absent. Antennae long, with 19-23 segments. Pronotum narrower than head, slightly saddle-shaped. Meso- and metapleura sometimes (*Archotermopsis*) with lateral expansions. Tarsi imperfectly 5-segmented; apical tibial spur formula variable, 4: 2-3 : 2; spurs and larger spines sometimes with a few microscopic papillae. Cerci with 5-7 segments.

## 2. *Distribution and Composition of Termopsidae*

*Living* : Nearctic, Oriental, slightly Palaearctic, thus : N. America (Canada, U.S.A.); NW Himalayas (N. India, Pakistan, eastern Afghanistan); and SE Asia.

*Fossil* : Europe and N. America.

### *Genera included in Termopsidae*

*Living* : *Archotermopsis* Desneux (also fossil); *Hodotermopsis* Holmgren and *Zootermopsis* Emerson (also fossil).

*Fossil only* : *Termopsis* Heer, *Xestotermopsis* von Rosen (systematic position doubtful) and *Parotermes* Scudder.

Of the three living genera, only *Archotermopsis* occurs in the Indian Region (NW Himalayas). *Hodotermopsis* occurs only in SE Asia (Indo-China and Formosa (Taiwan)); *Zootermopsis* is Nearctic (N. America.)

### Genus 1. *Archotermopsis* Desneux

1. Subgenus *Archotermopsis* (of genus *Termopsis* Heer) :

1904. Desneux, *Genera Insectorum*, Fasc. 25, *Isoptera*, Fam. *Termitidae*, Brussels, pp. 13-14 (Fig. 3, Im., head).

2. Genus *Archotermopsis* Desneux.

1911. Holmgren, *K. Sv. Vet. Akad. Handl.*, 46(6): 35-36.

1933. Emerson, *Calif. Univ. Publ. (Ent.)*, 6(6): 168, 172-173.

1949. Snyder, *Smiths, misc. Coll.*, 112: 55.

Type of genus (by monotypy) : *Termopsis (Archotermopsis) wroughtoni* Desneux, 1904, Kashmir (N. India).

#### 1. *Characters of Genus Archotermopsis*

*Imago* : Head round. Eyes large, reniform. Ocelli small. Antennae long, with 19-25 segments. Left mandible with 3 marginal teeth; right mandible with 2 large teeth and sometimes one small (subsidiary) tooth. Pronotum rather small, flat, narrower than head. Legs long; tibia with 3-4 lateral spines, apical spur formula 4 : 3-4 : 2; spines and spurs with lateral rows of microscopic, lamellate papillae. Tarsi imperfectly 5-jointed (4 visible above, 5 below). Wings covered on both surfaces with microscopic cuticular papillae in rows near margins; no other microsculpturing; also with a reticulum of veinlets. Forewing with Rs much-branched (5-6); anal absent. Hindwing like forewing, but a small anal present. Cerci very long, with 6-8 joints.

*Soldier* : Head rectangular, flattened. Eyes rudimentary. Ocelli small. Antennae long, with 22-27 segments. Mandibles powerful, almost as long as head, with two or more teeth. Pronotum small, flat, narrower than head. Legs as in imago; apical tibial spurs 3-4 : 2-3 : 2. Cerci long, with 6-7 joints.

*Pseudoworker* : True workers not present. Head subquadrate. Eyes small, rudimentary. Ocelli absent. Antennae long, with 19-23 segments. Mandibles as in imago. Apical tibial spurs 4 : 2-3 : 2.

## 2. *Composition and Distribution of Archotermopsis*

*Archotermopsis* has a single living species, *A. wroughtoni* Desneux, and a fossil one, *A. tornquisti* von Rosen (Baltic amber of E. Europe, Upper Eocene or Lower Oligocene).

*Distribution* : The single living species is largely Oriental and occurs in the North-West Himalayas (NW India and NW Pakistan), and just enters the Palaearctic Region in SE Afghanistan.

### 1. *Archotermopsis wroughtoni* (Desneux)

(Figs. 72-77)

(Syns. *radcliffei* Radcliffe and *deodarae* Chatterjee & Thakur.)

#### 1. *Termopsis wroughtoni* Desneux:

1904a (Feb. 15). Desneux, *J. Bombay nat. hist. Soc.*, 15: 445-446. Im, S. Type-locality : Kashmir Valley (India).

1904b (Mar. 29). Desneux, *Annals Soc. ent. Belg.*, 48: 280-285. India.

1934. Margabandhu, *J. Bombay nat. Hist. Soc.*, 37(3): 711. Kashmir (India).

#### 2. *Termopsis radcliffei* Radcliffe.

1904 (Sept.). Radcliffe, *Indian Forester* 30(9): 412-414. Type-locality : Kashmir (India).

#### 3. *Termopsis (Archotermopsis) wroughtoni* Desneux.

1904 (Nov. 15). Desneux, *Genera Insectorum (Isoptera, Fam. Termitidae)*, Brussels, Fasc. 25: 13-14; Fig. 3; and Pl. 1, Fig. 3.N. India, including Kashmir.

1906. (Sept. 20). Desneux, *J. Bombay nat. Hist. Soc.*, 17(2): 293-298, 3 figs. (Im. head; and S.). Fuller description.

1909. Lefroy, *Indian Insect Life*, Calcutta, 1: 116 (Fig. 48, dealate ♂ and S.) and 119. Kashmir (India).

#### 4. *Archotermopsis wroughtoni* (Desneux) :

1911. Holmgren, *K. Sv. Vet. Akad. Handl.*, 46(6): 36, Fig. 3 (wing), Pl. 1, Fig. 6(S), Pl. 2, Fig. 1 (Im). Im, S, W. Kashmir (India).

1912. Fletcher, *Agric. J. India*, 7(3): 222, 223 (Fig. 7 dealate and S)

1913. Holmgren, *K. Sv. Vet. Akad. Handl.*, 50(2): 31; Pl. 1, Fig. 1 (S.). Im, S., W.

1919. Imms, *Philos. Trans. roy. Soc. London*, (B)209: 75-180, 6 pls. (pls. 75-80). Im, S, W. Several places in Kashmir and Uttar Pradesh (ca. 4000-9000 ft.). Morphology and biology.
- 1914a. Beeson, *Indian forest Rec. (N.S.) (Ent.)*, 4 (2): 53.
- 1941b. Beeson, *Ecology and Control of Forest Insects in India, etc.* : 525 (Fig. 151, No. 1, S head) and 539-540. (Reprint 1961 : 404, 415-416.)
1949. Snyder, *Smiths, misc. Coll.*, 112: 55. N. India.
1953. Roonwal and Pant, *Indian Forest Leaflet (Ent.)*, No. 121(3) : 46. India : Uttar Pradesh (several places in Himalayas and foothills).
1954. Chaudhary, *Pakistan J. Forestry*, 4(1) : 31-32.
1955. Saleem, *Biologia (Lahore)*, 1(1): 34-39. Murree Hills (Panjab, Pakistan). Protozoan parasites.
1955. Ahmad, *Biologia (Lahore)* 1(2): 208. Im, S. Hazara Dist. (Pakistan); and Muzaffarabad Dist. (Kashmir, India).
1958. Bhasin, Roonwal and Singh, *Indian Forest Bull. (Ent.)*, (N.S.), No. 171(2): 102.
1962. Mathur and Thapa, *Indian Forest Leaflet (Ent.)*, No. 161: 6.
1967. Chatterjee and Thakur, *Indian Forest Rec. (Ent.)*, 11(1): 8-10.
1967. Harris, *Acta Mus. Moraviae, (Sci. nat.)*, 52 (Suppl.) : 211, 214. (E. Afghanistan).
1970. Roonwal, In *Biology of Termites* (Eds. Krishna and Weesner), Vol. 2: 328-329.
1970. Roonwal and Bose, *Sci. and Cult.*, 36: 673. (Papillae on tibial spines and spurs.)
1972. Chaudhry and Ahmad, *Termites of Pakistan* (Final Tech. Report P.L. 480: 9. NW Pakistan.
1974. Akhtar, *Pakistan J. Zool.*, 6: 90-91.
1980. Sen-Sarma and Thakur, *Indian Forest Rec. (Ent.)*, 14(1): 7-8. Kumaon Hills: Barechana Forest Range (Almora dist., U.P.), 1350 m.
1981. Roonwal. *Proc. Indian natnl. Sci. Acad.*, (B) 47: 469-470. Wing microsculpturing.
1983. Roonwal, *Zool. Anz.*, 211: 138-139. Papillae on tibial spines and spurs.
1983. *Proc. Indian natnl. Sci. Acad.*, (B)49: 377-378. Wing microsculpturing.
1984. Roonwal, *Mem. ent. Soc. India*, No. 9: 11-12. (Abdomen and genitalia.)
1984. Roonwal, Bose and Verma, *Rec. zool. Surv. India*, 81 (3-4): 315-338. (Taxonomy and distribution.)
- 5. *Archotermopsis deodarae* Chatterjee and Thakur:**
1967. Chatterjee and Thakur, *Indian Forest Rec. (N.S.) (Ent.)*, 11(1): 10-13, Pl. 1. S, Pw. Kashmir (India).

IMAGO : (figs. 72-74): Head reddish brown to pale brown, mandibles darker; rest of body golden yellow. Moderately pilose. Total length with

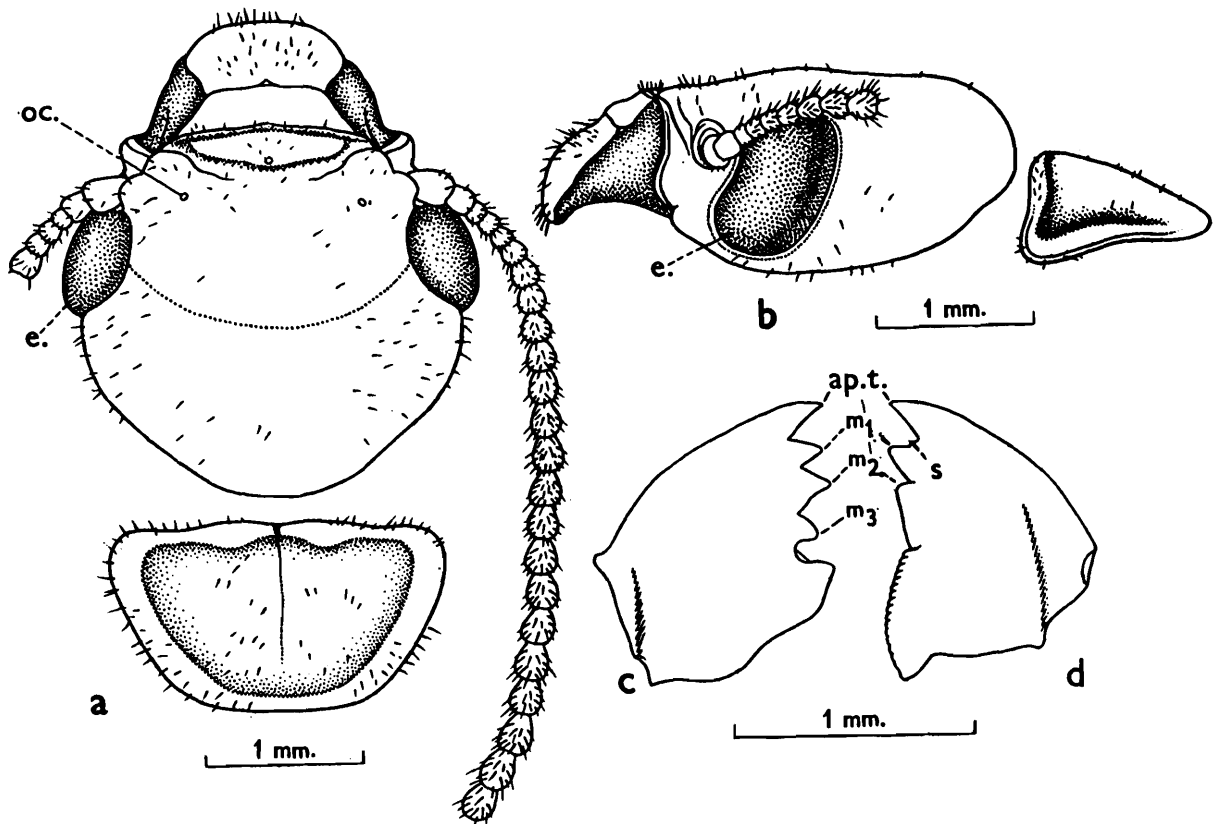

Fig. 72. *Archotermopsis wroughtoni*. Imago. (a) Head and pronotum, in dorsal view. (b) Same, in side view. (c) Left mandible. (d) Right mandible.  
ap. t., apical tooth; oc., ocellus; e., eye; m1 - m3, first to third marginal teeth; s., subsidiary tooth.

wings 23.6-26.0 mm; without wings 10.7-14.0 mm. Head-capsule subcircular (width 2.25-2.70 mm; length to mandible-base 1.88-2.40 mm). Fontanelle absent. Eyes large, subreniform (diameter 0.85-1.10 × 0.57-0.77 mm). Ocelli paired, small, as minute spots. Antenna long, with 19-25 segments; 3 shortest. Anteclypeus apilose; postclypeus narrow, not well differentiated, with a few short bristles. Labrum large (0.50-0.75 × 0.83-1.06 mm), subquadrate. Left mandible with 3 marginal teeth. Right mandible with 2 well developed marginals and, in addition, a small subsidiary tooth at the front base of the first marginal. Pronotum flat, narrower than head; broader than long (length 0.97-1.22, width 1.80-2.22 mm) Mesonotum and metanotum broader than pronotum. Wings covered with rows of microscopic, thorny to subcrescentic papillae at anterior and posterior margins; and with a reticulum of veinlets. Forewing (length 22.5 mm) with a large scale; all principal veins arising inside scale; C long,

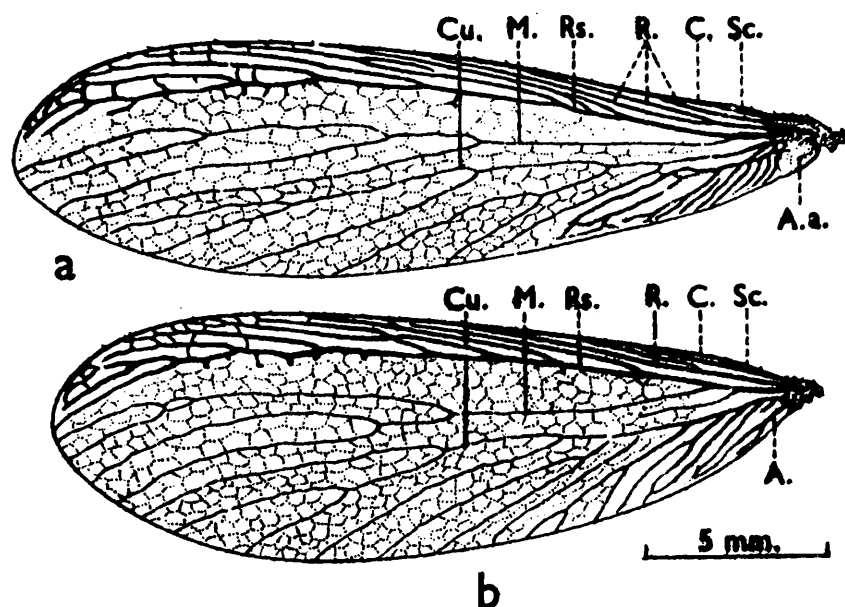

Fig. 73. *Archotermopsis wroughtoni*. Wings. (a) Forewing. (b) Hindwing.

A., anal; A.a., anal area; C., costa; Cu., cubitus; M., media; R., radius; Rs., radial sector; Sc., subcosta.

marginal; Sc small; R 3-branched; Rs arising from R, and with 5-6 branches; M arising from Rs outside the scale, with 6-7 branches; and Cubitus with 6 branches; anal absent. Hindwing (length 20.5 mm), almost like forewing, but scale small; an anal present. Legs long.; tarsi imperfectly 5-segmented (4 from above, 5 below), with an arolium between claws. Tibia with a few lateral spines; apical spurs formula 4: 3-4 : 2.; spines and spurs laterally bear several microscopic, lamellar papillae (26-36 on a spur). Cerci long (1.0-1.48 mm), with 6-8 joints. Styli (in male) one-jointed, long (0.40-0.58 mm), extending beyond tip of abdomen.

**SOLDIER** (Fig. 75): Head deep reddish brown; mandibles blackish red; antennae reddish brown proximally, paler distally; rest pale creamish yellow. Total length with mandibles variable, 11.4-21.1 mm. There is an enormous range of size variation, but no separation into major and minor soldiers can be made, there being a graded series. Head-capsule subsquarish, a little longer than broad (width 2.55-4.50 mm, length to mandible-base 2.80-5.20 mm); head-length with mandibles 6.37-7.00 mm.; head slightly narrowing anteriorly; posterior margin with a pair of shallow depressions. Fontanelle absent. Eyes as small, brown patches. Ocelli as a pair of small

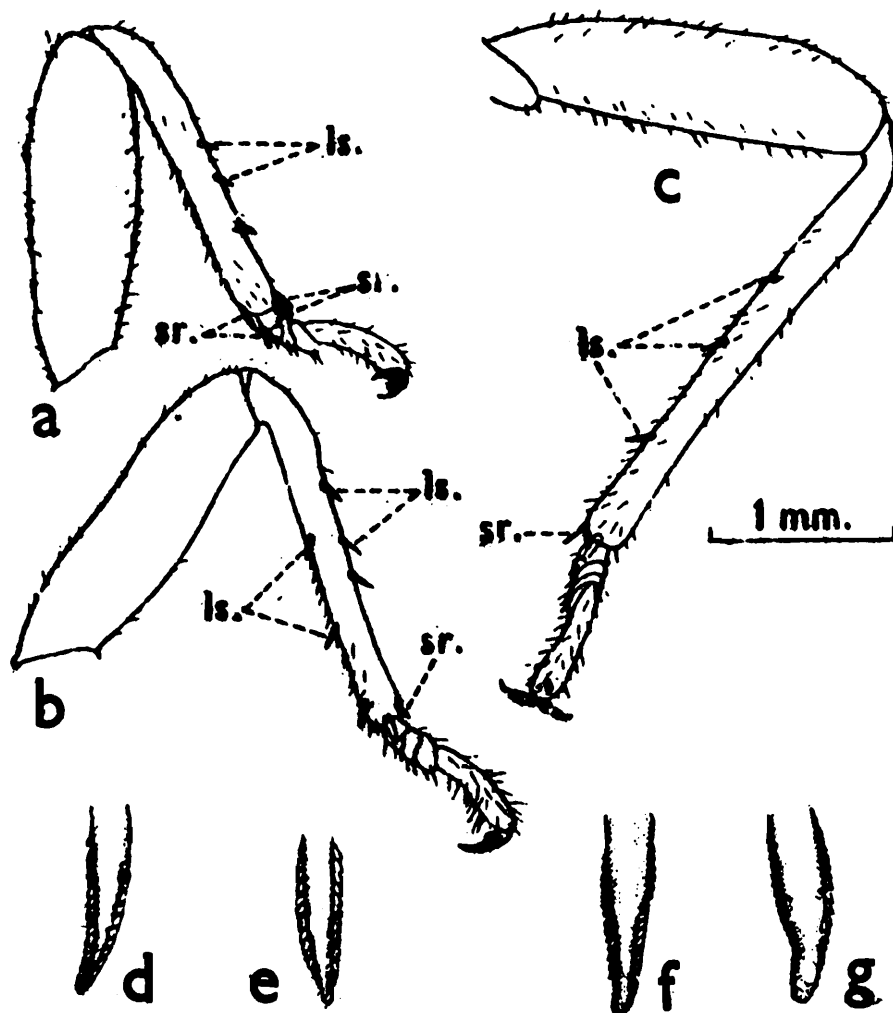

Fig. 74. *Archotermopsis wroughtoni*. Legs of imago. (a). Foreleg. (b) Middle leg. (c) Hind leg. (d-g) Apical tibial spurs of fore leg, to show lamellar papillae at margins; greatly magnified.

Is., lateral spines of tibiae; sr., apical tibial spurs.

white spots. Antennae long, with 22-27 segments (3 shortest, 4 and 5 subequal). Anteclypeus narrow, apilose. Postclypeus small, with a few short bristles. Labrum subsquarish, broader than long ( $0.33-0.80 \times 0.63-1.10$  mm), broadest in middle; anterior margin with a shallow, median incurving; with several short bristles. Mandibles long and stout (length 2.10-4.80 mm), distally strongly incurved and pointed. Right mandible with an apical and 2 marginal teeth; marginal 1 small, 2 large. Left mandible with an apical and 3 marginal teeth; marginals 1 and 2 large, 3 small. Postmentum long, narrow (median length 2.23-4.43, maximum width 0.7-1.2 mm), with a gentle waist below the middle; posterior margin weakly concave. Pronotum broader than long ( $0.95-1.95 \times 1.53-3.03$  mm), the

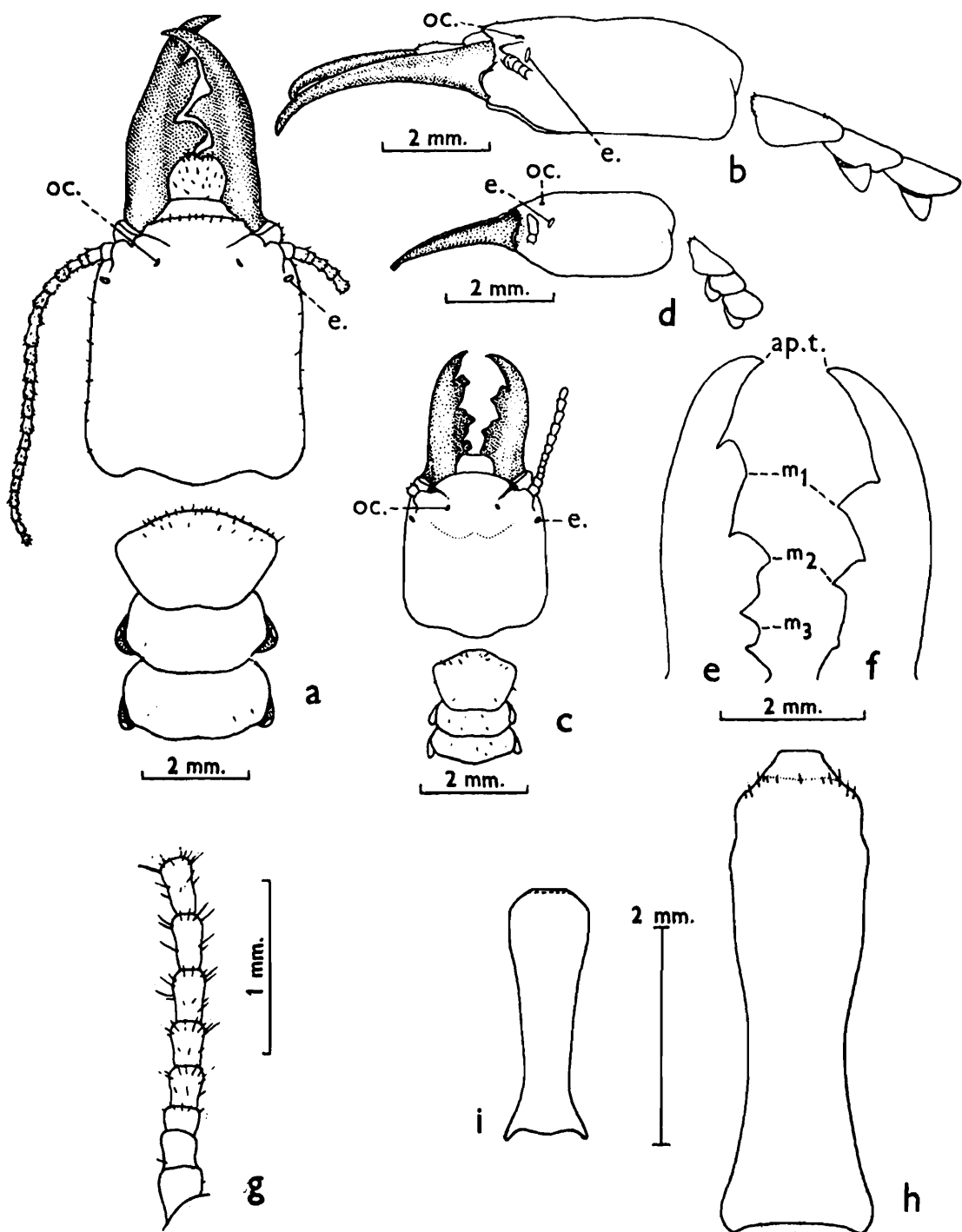

Fig. 75. *Archotermopsis wroughtoni*. Soldiers (There is enormous size-variation, but there is a grades series and no separation into major and minor soldiers is possible.) (a) Head and thorax of large soldier, in dorsal view; note the pleural processes of meso- and metathorax. (b) Same, in side view. (c) Same, small soldier, in dorsal view. (d) Same, in side view. (e) Left mandible of large soldier. (f) Same, right mandible. (g) Basal part of antennae of large soldier. (h) Postmentum of large soldier, in ventral view. (i) Same, of small soldier.

ap.t., apical tooth of mandibles; m1 - m3, first to third marginal teeth of mandible; oc., ocellus.

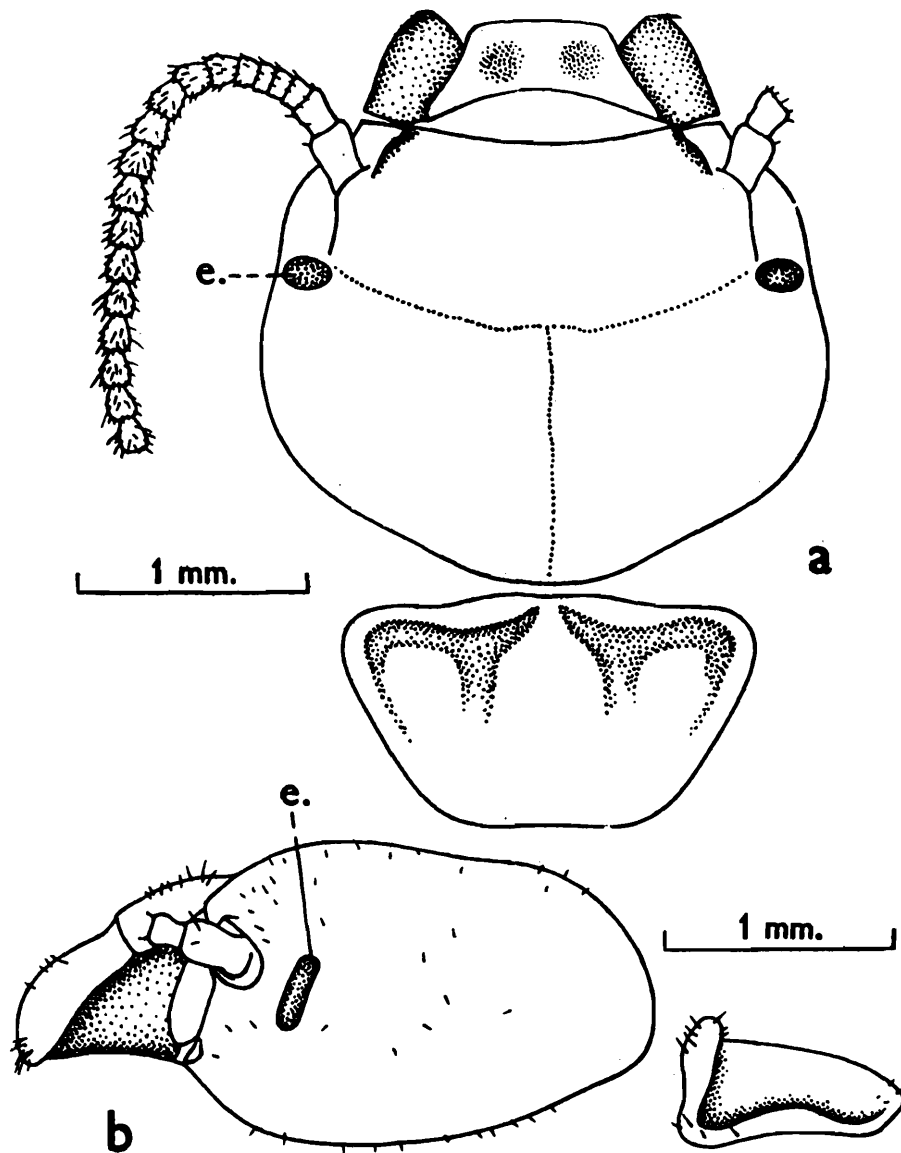

Fig. 76. *Archotermopsis wroughtoni*. Pseudoworker. (a) Head and pronotum, in dorsal view. (b) Same in side view.  
e., eye.

sides narrowing posteriorly; anterior margin substraight to convex. without a median notch; posterior margin substraight, with a weak median notch, a few hairs present on margins and on body. Mesonotum and metanotum narrower than pronotum; posterior margins with a weak median incurving; the pleura laterally expanded to form small, subtriangular flaps (the epimera). Legs long, stout, pilose; imperfectly 5-segmented (4 above, 5 below), apical spur formula 3-4 : 2-3: 2; the larger spines and spurs laterally bear several (12-13) microscopic papillae. Cerci long, (1.86-2.40 mm), with 6-7 joints. Styli in both sexes one-jointed, 0.53-0.93 mm long. Sexes separable; sternum 7 enlarged in females.

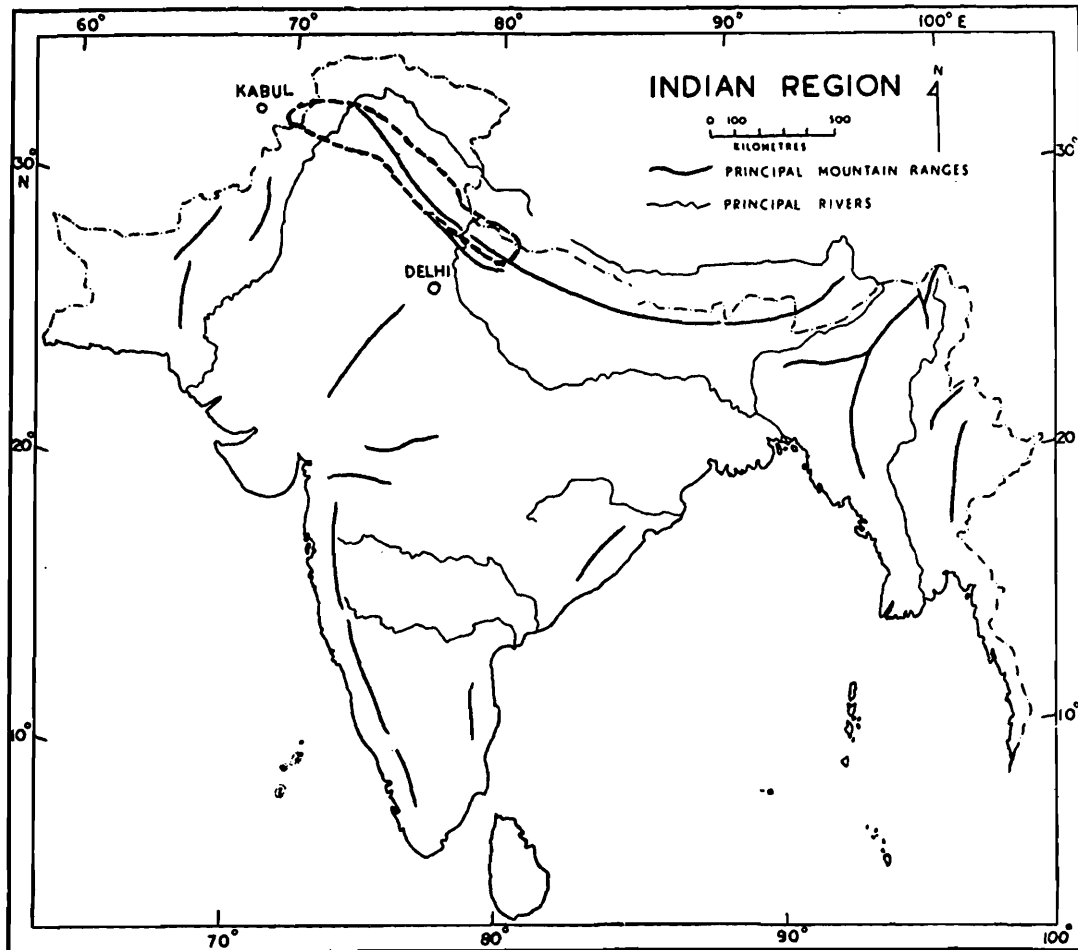

Fig. 77. *Archotermopsis wroughtoni*. Geographical distribution (area enclosed in broken line).

**PSEUDOWORKER (Fig. 76):** Head posteriorly deep creamish yellow, mandibular teeth darker; rest paler. Sparsely pilose. Total length 7.8-13.1 mm. Head subquadrate, broader than long (width 1.70-2.60, length 1.45-2.38 mm). Fontanelle absent. Eyes present as small brown patches; ocelli absent. Antennae with 19-23 segments. Mandibles as in imago. Pronotum weakly saddle-shaped; meso- and metapleura with lateral pleural flaps, as in soldier. Legs long; apical tibial spur formula 4 : 2-3 : 2; spurs and larger spines with a few (4-5) microscopic papillae laterally.

**Distribution (Fig. 77):** Mainly oriental (NW Himalayas in India and Pakistan) and just entering the Palearctic Region (eastern Afghanistan); at higher altitudes, ca. 900-3000 m; in coniferous forests.

**INDIA:** States of Uttar Pradesh (districts of Dehra Dun, e.g. Jhajra, Chakrata; Nainital, e.g. Bhowali; Almora; Garhwal; Tehri; Uttar Kashi), Himachal Pradesh (Manali in Kulu Valley and near Narkanda); and Jammu and Kashmir (Kashmir Valley and Muzaffarabad District).

**PAKISTAN :** North West Mountain area.

**AFGHANISTAN :** Barikot (Nengrahar Province, eastern Afghanistan near Pakistan border).

*Remarks :* *A. deodarae* Ch. & Th. has been separated (in soldiers) from *wroughtoni* on minor and inconsequential characters all of which fall well within the range of the latter. The supposed differences in the anterior margin of pronotum [given as "interior", evidently an error, by Chatterjee and Thakur 1967] (with a weak depression in *deodarae* vs. convex) do not hold good; and there is a wide range, even in local populations (for discussion, vide Roonwal, Bose and Verma, 1984).

*Biology :* The species occurs in high altitudes (900-3000 m) in coniferous forests and attacks rotting wood; living wood is not attacked. Colonies are small (30 or 40 individuals) and live in long, vertical galleries; there is no external sign of attack. Breeding occurs inside the wood. Swarming occurs during the monsoon (June-August). (For details see Roonwal 1970a and Roonwal, Bose and Verma, 1984.)

## Family II. HODOTERMITIDAE Desneux

1. Tribe Hodotermitini of Subfamily Calotermitinae of family Termitidae :

1904. Desneux, *Genera Insect.*, Fasc. 25: 14. (Included genera *Hodotermes*, *Stolotermes* and *Porotermes*)

2. Subfamily Hodotermitinae of Protermitidae :

1910. Holmgren, *Zool. Anz.*, 35: 285.

1911. Holmgren, *K. Sv. Vet. Akad. Handl.*, 46(6): 34, 40, 41-45.

3. Tribe Hodotermitinae :

1930. Handlirsch. In *Kukenthal's Handb. Zool.*, 4(8): 856.

4. Family Hodotermitidae :

1925. Snyder, *Proc. biol. Soc. Washington*, 38: 158.

1925. Sjöstedt, *Konowia*, 4(1-2): 53-55.

1926. Sjöstedt, *K. Sv. Vet. Akad. Handl.*, (3) 3(1): 9.

1932. Brues and Melander, *Bull. Mus. Comp. Zool. Harvard Coll.*, 73: 95.

1942. Emerson, *Am. Mus. Novit.*, No. 1178: 10-11.

1949. Snyder, *Smiths. misc. Colls.*, 112: 54.

1949. Grasse, *Traite de Zoologie* Vol. 9: 531.
1950. Ahmad, *Bull. Am. Mus. nat. Hist.*, 95 (Art. 2): 51-52.
1955. Emerson, *Fieldiana. Zool.*, 37: 473, 483, 484, 490, 492, 498, 499, 502, 506, 507, 509, 516, 517.
1955. Ahmad, *Biologia*, Lahore, 1(2): 203, 207.
1955. Weidner, In *Die Termiten* (Ed. Schmidt): 10, 52, 91-92.
1958. Ahmad, *Biologia*, Lahore, 4(1 & 2): 34, 35.
1961. Harris, *Termites : Their Recognition Control.*: 44-45 (Rev. ed. 1971).
1968. Emerson, *Am. Mus. Novit.*, No. 2332: 2-6.
1970. Krishna, In *Biology of Termites* (Eds. Krishna and Weesner) Vol. 2: 330-332.
1975. Emerson and Krishna, *Am. Mus. Novit.*, No. 2570: 13, 15, 16, 18, 19, 26-27.
1979. Roonwal, *Termite Life and Termite Control in Tropical South Asia*: 4, 8, 9.
1984. Bose, *Occ. Pap. Rec. zool. Surv. India*, No. 49: 13, 14, 70-72.
1986. Grasse, *Termitologia* Vol. 3: 503-504.
5. Calotermitinae (Part):
1896. Froggatt, *Proc. Linn. Soc. N.S.W.*, 21: 516.
1930. Handlirsch, In *Kukenthal's Handb. Zool.*, 4(8): 857. (Refers as Tribe Calotermitinae)
1939. Statz, *Decheniana* 99A: 35, pl. 4.
6. Calotermitidae (Part):
1942. Hill, *Termites (Isoptera) from the Australian Region* : 6-7.
1944. Kelsey, *New Zealand J. Sci. Tech.*, (B) 25(6): 236.
7. Mastotermitidae (Part):
1938. Zeuner, *Palaeontol. Zeitsch.*, 20: 113 (includes *Ulmeriella*)
8. Termopsini (Part):
1939. Statz, *Decheniana* 99A: 13.

Desneux (1904f) erected the tribe Hodotermitini including the genera *Hodotermes*, *Stolotermes* and *Porotermes*. As such Desneux becomes the author of the family Hodotermitidae in accordance with the rules of zoological nomenclature even though Holmgren (1910, 1911c), Sjöstedt (1925) and Snyder (1925) were the first to have used the name Hodotermitinae/Hodotermitidae as a subfamily or family name.

Snyder (1949) in his Hodotermitidae included the subfamilies Termopsinae Holmgren, Stolotermitinae Holmgren, Porotermitinae

Emerson and Hodotermitinae Holmgren. Grassé (1949), however, split the family into 2, viz. Termopsidae (including Termopsinae, Porotermitinae and Stolotermitinae), and Hodotermitidae.

In the present volume we have followed Snyder (1949) except that Termopsinae has been given the status of a family (*supra*).

### 1. Characters of Family Hodotermitidae (*sens.lat.*)

*Imago* : Frontal gland absent. Eyes present, generally well developed. Ocelli absent (rudiments sometimes present in some Stolotermitinae and Hodotermitinae). Mandibles with a small subsidiary tooth generally present at base of anterior edge of the first marginal tooth of right mandible (the subsidiary tooth greatly reduced or absent in some Hodotermitinae). Antennae long and filiform with numerous (13-31) segments. Pronotum narrower than head; either flat or saddle-shaped. Forewing-scales partly or completely overlapping the hindwing-scales. Wings almost hairless; wing microsculpturing consisting of papillae, in several rows, on anterior veins and pimpules all over the membrane in Hodotermitinae and Porotermitinae and papillae on veins and simple or complex micrasters on membrane in Stolotermitinae. Tarsi either 4-segmented or incomplete 5-segmented (4 visible above and 5 below); with or without pulvilli. Cerci with 1-5 segments. Styli generally present, rarely absent.

#### *Note on Wing Microsculpturing in Hodotermitidae :*

The wing microsculpturing in Hodotermitidae consists of three elements, viz. papillae, pimpules and micrasters on both sides of the membrane. Of these all the three elements may not be present in the same species. The wings are almost hairless, but sometimes a few hairs may be present on the margins. Microsculpturing in the three subfamilies is as follows:

In Hodotermitinae papillae are present on anterior veins. Their size varies from 3-6  $\mu\text{m}$  and density is approx. 8750/ $\text{mm}^2$  (in *Anacanthotermes macrocephalus*). The pimpules, present all over the wing surface, vary from 2-3  $\mu\text{m}$  in size, with a density of 4000/ $\text{mm}^2$ . In Stolotermitinae the pimpules are absent while papillae on anterior veins and micrasters on membrane, both simple and asteroid, are present. The size of papillae varies from 5-9  $\mu\text{m}$  and the density from 6000-6850/ $\text{mm}^2$  and that of micraster from 5-9  $\mu\text{m}$  in size and 3145-4570/ $\text{mm}^2$  in density. In

Porotermitinae also only papillae and pimpules are present as in Hodotermitinae. The size of papillae varies from 3-9  $\mu\text{m}$  with a density of 2000-2860/ $\text{mm}^2$ . The size and density of pimpules are 1-5  $\mu\text{m}$  and 3145-4285/ $\text{mm}^2$ , respectively.

**Soldier** : Large and robust, with strong well developed mandibles having a number of large well formed triangular teeth on inner margin. Ocelli generally absent, but rudiments sometimes present (*Anacanthotermes*). Eyes generally present (more or less reduced in Portotermitinae). Antennae long and filiform, with numerous (13-33) segments. Pronotum narrower than or as wide as head; either flat or saddle-shaped. Tarsi as in imago.

**Worker** : With or without a true worker caste. Workers, when present, usually with eyes.

**Habits** : Are either harvesters (ground-foragers and grass-cutters) or live inside moist wood (logs, dead trunks, etc.).

## 2. Distribution and Composition of Family Hodotermitidae

**Distribution** : The living species are widely distributed all over the world (Asia, Africa, S. America and Australia) and cover most of the zoogeographical regions, viz., Neotropical, Palearctic, Ethiopian, Oriental and Australian.

**Composition** : Hodotermitidae (*sens. lat.*) comprises four subfamilies and several living genera as follows (those occurring in the Indian Region being marked with an asterisk):

Subfam. Stolotermitinae : *Stolotermes*.

Subfam. Porotermitinae : *Porotermes*.

Subfam. Hodotermitinae\* : *Hodotermes*, *Microhodotermes* and *Anacanthotermes*\*.

Subfam. Cretatermitinae (Fossil) : *Cretatermes*.

Grassé (1986) places the subfamilies Stolotermitinae, Porotermitinae and Cretatermitinae in the family Termopsidae. We have, however, followed the arrangement of Snyder (1949) and Emerson (1968) except for the Termopsinae which is given the status of a family.

### 3. Keys to the Living Subfamilies of *Hodotermitidae*

#### IMAGOES

- 1(4). Left mandible with 3 marginal teeth. Cerci long with 4-5 joints. Styli well developed, present in male only. Antennae not long with 13-19 segments. Wing surfaces with or without micrasters and pimpules; papillae present
- 2(3). Cerci 5-segmented. Wing surfaces not covered with micrasters; only papillae and pimpules present..... **Porotermitinae**
- 3(2). Cerci 4-segmented. Wing surfaces covered, besides papillae, with micrasters; no pimpules..... **Stolotermitinae**
- 4(1). Left mandible generally with 2 (sometimes 3) marginal teeth. Cerci short, conical, with 1-5 joints. Styli short, present in both sexes. Antennae long, filamentous, with 23-31 segments. Wing surfaces without micrasters; only papillae and pimpules present..... **Hodotermitinae**

#### SOLDIERS

- 1(4). Head long. Antennae short, with 13-18 segments. Pronotum flat; either slightly or markedly narrower than head
- 2(3). Mandibles shorter, about one-third the head-length. Pronotum only slightly narrower than head. Apical tibial spurs formula 2:3:4. Cerci 5-segmented..... **Porotermitinae**
- 3(2). Mandibles longer, about one-half the head-length. Pronotum markedly narrower than head. Apical tibial spurs formula 2-3:2-3:2. Cerci 4-segmented..... **Stolotermitinae**
- 4(1). Head subsquarish, only slightly longer than wide. Antennae long, filamentous, with 23-33 segments. Pronotum saddle-shaped, much narrower than head..... **Hodotermitinae**

From the Indian Region the subfamily *Hodotermitinae* only (genus *Anacanthotermes*) is known and discussed as under :

#### Subfamily HODOTERMITINAE Desneux

##### 1. Tribe *Hodotermitini* :

1904. Of subfamily *Calotermitinae* of family *Termitidae* Desneux, *Genera Insectorum*, Fasc. 25: 14.

##### 2. Subfamily *Hodotermitinae* :

1911. Holmgren, K. *Sv. Vet. Akad. Handl.*, 46(6): 34, 40, 41-45 [except *Pterotermes* (= *Kalotermes*)].

1942. Emerson, *Am. Mus. Novit.*, No. 1187: 11.

1949. Snyder, *Smiths. misc. Colls.*, 112: 54, 59.  
1950. Ahmad, *Bull. Am. Mus. nat. Hist.*, 95(Art. 2): 52.  
1968. Emerson, *Am. Mus. Novit.*, No. 2332: 4-6.  
1970. Krishna, In *Biology of Termites* Vol. 2: 136.  
1975. Emerson and Krishna, *Am. Mus. Novit.*, NO. 2570: 26, 27.  
1984. Bose, *Occ. Pap. Rec. zool. Surv. India*, No. 49: 70-71.

Type Genus : *Hodotermes* Hagen

### 1. Characters of Subfamily Hodotermitinae

**Imago** : Head large, subsquarish to subround, flat above. Head sutures distinct. Fontanelle absent. Compound eyes small, oval, forwardly placed. Ocelli (the so called antennal organs of some authors) present in front of antennae, and can be seen raised, in lateral view. Clypeus fairly developed, and flat. Mandibles of *Hodotermes*-type. Left mandible with an apical and 2-3 marginal teeth; the right mandible with 2 marginal teeth, but in some species with a small subsidiary tooth at the base of anterior edge of the first marginal. Antennae thin, and with numerous (23-31) segments. Pronotum relatively small, much narrower than head, saddle-shaped; with a more or less well developed anterior flap. Wing membrane transparent, with a fine reticulation of cross-veins. Forewing: Costa (C) well marked; subcosta (Sc) small. Radius (R) complex, relatively weak. Radius and radial sector (Rs) arising from a common stem, both sending branches to the wing-margin. Media (M) weak and lying close to cubitus. Cubitus (Cu) well developed and with numerous branches. Hindwing: Subcosta longer than in forewing. Media arising from base of radial sector. Anal area with rudimentary anal vein. Legs fairly long and slender; tibia either without or with several lateral spines; apical tibial spurs present as follows: Fore-tibia 3, middle-tibia 3-4, hind-tibia also 3-4. Tarsi with 4 segments and without pulvilli. Cerci short, with 1-5 segments. Styli small, one-jointed, present in both sexes, rarely absent.

**Soldier** : Head relatively short and thick, with rather short but very strong mandibles. Left mandible with 3, the right with 2 strong teeth. Eyes present. Ocelli present or absent. Antennae with 23-33 segments. Pronotum saddle-shaped and with well-marked anterior flap. Anterior angles extending more or less laterally. Legs long; tibia with 3-4 apical

spurs, and without or with a number of lateral spines. Tarsi with 4 segments. Cerci and styli short.

*Worker* : Head large and subcircular. Clypeus small, flat. Mandibles as in imago. Antennae with 23-33 segments. Eyes present, dark. Ocelli present or absent. Pronotum saddle-shaped, with clear anterior flap. Legs long. Tibiae and tarsi as in soldier. Cerci and styli short.

*Mode of living* : Colonies generally living underground, with all castes (Imagoes, soldiers and workers). The neuters (soldiers and workers) sometimes of two types (major and minor), and foraging above ground, often for grass-cutting.

## 2. *Distribution and Composition of Hodotermitinae*

*Distribution* : Living : Africa to India.

Fossil : Europe and Siberia.

*Composition* : Genera included :

1. *Hodotermes* Hagen. Ethiopian and Palaeartic.
2. *Microhodotermes* Sjöstedt. Ethiopian and Palaeartic.
3. *Anacanthotermes* Jacobson. Palaeartic, Ethiopian and Oriental.
4. *Ulmeriella* Meunier (fossil). Oligocene, Miocene and Pliocene. Europe and N. America.

Of these only *Anacanthotermes* occurs in the Indian region and is discussed below :

### Genus 2. *Anacanthotermes* Jacobson

#### 1. Subgenus *Anacanthotermes* of *Hodotermes* Hagen:

1905. Jacobson, *Ann. Mus. Zool. Acad. Imp. Sci.*, 9(1904): 75-78.

1911. Holmgren, *K. Sv. Vet. Akad. Handl.*, 46(6): 43.

#### 2. Genus *Anacanthotermes* Jacobson:

1926. Sjöstedt, *K. Sv. Vet. Akad. Handl.*, (3) 3(1) (1925): 9, 10, 21.

1941. Emerson, *Am. Mus. Novit.*, No. 1187: 9, 11.

1949. Snyder, *Smiths. misc. Colls.*, 112: 62.

1950. Ahmad, *Bull. Am. Mus. nat. Hist.*, **95**(Art. 2): 51, 52.
1955. Ahmad, *Biologia*, Lahore, **1**(2): 207.
1955. Emerson, *Fieldiana: Zool.*, **37**: 473, 482, 509.
1958. Ahmad, *Biologia*, Lahore, **4**(1 & 2): 56.
1961. Harris, *Termites: Their Recognition Control*: 6, 45.
1968. Emerson, *Am. Mus. Novit.*, No. 2332: 4-5.
1970. Krishna, In *Biology of Termites* (Eds. Krishna and Weesner) Vol. 2: 135, 136.
1970. Roonwal, In *Biology of Termites* (Eds. Krishna and Weesner) Vol. 2: 330.
1974. Akhtar, *Pakistan J. Zool.*, **6**: 90-91.
1977. Chhotani, *Proc. VIII. int. Congr. Int. Un. Stud. Social Ins.* (Wageningen, 1977): 116.
1979. Akhtar, *Biologia*, Lahore, **25**: 161.
1984. Bose, *Occ. Pap. Rec. zool. Surv. India*, No. 49: 70-72.
1984. Weidner, *Anz. Schadling.*, **57**: 1, 5.
1985. Chhotani, *Zeit ang. Ent.*, **110**: 89-90.
1986. Grassé, *Termitologia* Vol. 3: 505.
1988. Roonwal and Bose, *Occ. Pap. Rec. zool. Surv. India*, No. 111: 2-4.

Type of genus: Jacobson (1905) did not designate the type of *Anacanthotermes*, but included in it the following 5 species and subspecies: *ochraceus* Burmeister, *ahngerianus* Jacobson, *vagans* Hagen, *vagans septentrionalis* Jacobson and *turkestanicus* Jacobson. Snyder (1949, p. 62), selected *ochraceus* Burmeister as the type of the genus and we accept it.

### 1. Characters of Genus *Anacanthotermes*

*Imago* : Head-capsule broadly rounded; head-sutures present. Fontanelle absent. Eyes small, oval. Ocelli either absent or rudimentary. Antennae with 24-31 segments. Clypeus flat, divided into an anteclypeus and a postclypeus. Mandibles with an apical and 3 marginal teeth; in left mandible 2nd marginal small and widely separated from 3rd; right with 2 large marginals and a small subsidiary tooth at anterior base of 1st marginal. Pronotum weakly saddle-shaped; anterior lobe slightly raised in front. Wings with fine reticulation; microsculpturing consists of papillae on anterior veins and pimpules on all over wing-membrane; costa (C.) thick, bordering the anterior margin; subcosta (Sc.) short; radius (R.) thick and sending off a few branches to costa before joining the latter in the middle or a little beyond the middle of wing; radial sector (Rs.) also thick, running

upto the distal tip of wing and with several branches to anterior border; media (M.) thin, arising separately from the wing-scale in the forewing, but from the radial sector outside scale in hindwing, and branching distally; cubitus (Cu.) thin and with several branches to the hind margin of wing; anal absent in forewing, and present as a small, weak vein in hindwing. Lateral tibial spines on legs absent; apical tibial spurs formula 3:4:4. Cerci and styli small, single jointed.

*Soldier* : Head-capsule subsquarish to subround; head-sutures weak. Fontanelle absent. Eyes blackish, small. Ocelli either small, dorsolateral, generally flush with head-surface or absent. Antennae, long, filiform, with 23-32 segments. Clypeus divided into an apilose, flat anteclypeus and a pilose, flat postclypeus; the latter not distinctly separated from frons. Mandibles thick and stout; left mandible with two prominent and sometimes with one or two short marginal teeth near base; right mandible with an apical and only two large marginal teeth. Postmentum short, club-shaped. Pronotum weakly saddle-shaped and slightly raised in front. Legs long; apical tibial spurs formula 3:4:4; lateral spines absent. Abdomen oblong; cerci and styli small, single jointed.

*Worker* : Head-capsule subcircular; head-sutures present. Eyes small, black and oval. Ocelli either small and placed dorso-laterally or absent. Antennae long, filiform, with 25-33 segments. Mandibles as in imago. Pronotum weakly saddle-shaped. Apical tibial spur formula 3:4:4.

## 2. Distribution and Composition of *Anacanthotermes*

*Distribution* (Fig. 78): The genus is known from the Palaearctic, Ethiopian and Oriental regions as follows:

From North Africa (Egypt, Algeria, Tunisia), Palestine, West Asia, Turkestan, Iran, Transcaspia, Arabia, Afghanistan, West Pakistan and India (Western desert region and S. India).

*Composition* : The following 12 species are included in *Anacanthotermes* : *ahngerianus* (Jacobson), *baekmannianus* (Vasiljev), *baluchistanicus* Akhtar, *macrocephalus* (Desneux), *murgabicus* (Vasiljev), *ochraceus* (Burmeister), *saudiensis* Chhotani and Bose, *septentrionalis* (Jacobson), *turkestanicus* (Jacobson), *ubachi* (Navas), *vagans* (Hagen) and *viarum* (Konig).

Of these only 4 namely, *baluchistanicus*, *macrocephalus*, *vagans* and *viarum* occur in the Indian region, and are, in fact, the only oriental species known, all others being Palaearctic and Ethiopian (North Africa to Arabia and West and Central Asia).

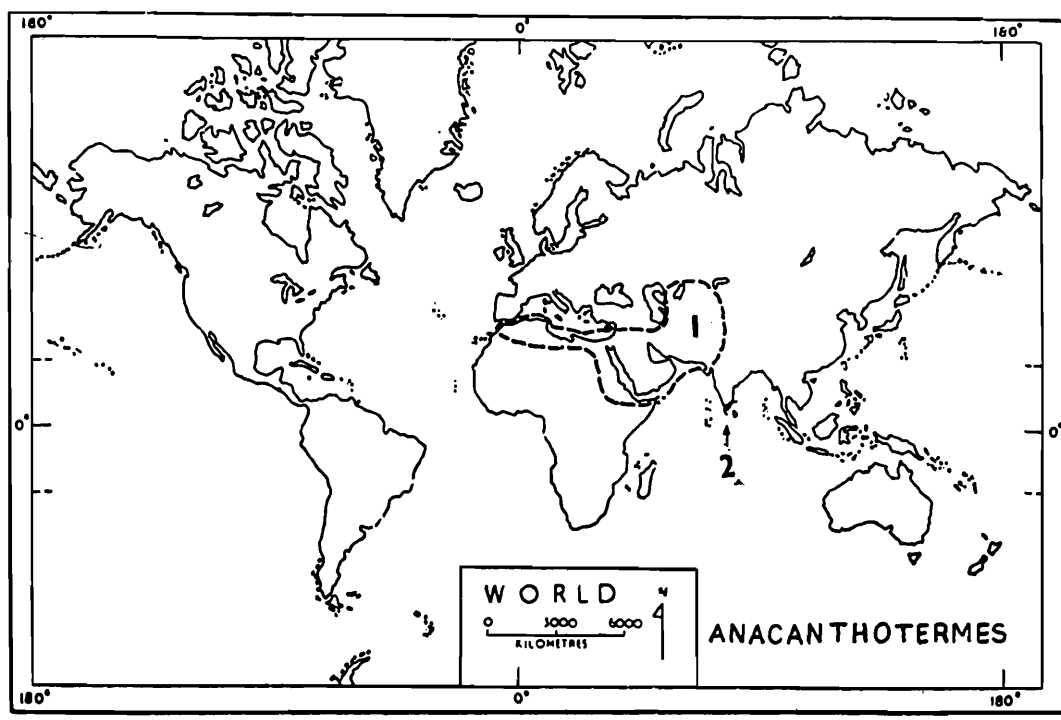

Fig. 78. World map, to show the distribution of genus *Anacanthotermes*. 1. North Africa, West and Central Asia to Western India (several species). 2. South India (*A. viarum*).

### 3. Keys to the Species of *Anacanthotermes* IMAGOES

Imagoes are known in case of 3 species only.

1(4) Labrum bulged in middle.

2(3). Larger species (length without wings 14.4-15.4; maximum head-width with eyes 3.20-3.42, maximum eye-diameter 0.63-0.70, maximum pronotum width 2.53-2.90 mm). Antennal segments more numerous, 29-31. Eyes more widely separated from antennae (minimum distance 0.13-0.16 mm).....

*viarum*

3(2). Smaller species (length without wings 12.5-15.0, maximum head-width 2.70-3.40, maximum eye-diameter 0.48-0.61, maximum pronotum - width 2.13-2.41 mm). Antennal segments fewer, 26-29, mostly 27 (24 in Afghanistan examples only). Eyes nearer antennae (minimum distance 0.05-0.08 mm).....

*macrocephalus*

4(1) Labrum not bulged in middle. [Smallest species (length without wings 11-13, maximum head-width 2.80-3.07, maximum eye-diameter 0.47-0.59, maximum pronotum-width 2.05-2.33 mm). Antennal segments 24-27].....

*vagans*

## SOLDIERS

- 1(2). Pronotum with posterior margin deeply notched in middle (Soldier major; wavy in minor). [Postmentum with sides of posterior third only weakly depressed, not forming a waist. Maximum head-width 2.91-3.53 mm. Antennae with 23-25 segments]..... *baluchistanicus*
- 2(1). Pronotum with posterior margin either not notched or only weakly depressed
- 3(4). Pronotum with posterior margin not notched. Postmentum with no marked waist in posterior third, [Small species : Head-length to mandible-base 2.44-2.91, maximum head-width 2.50-3.78 mm]..... *vagans*
- 4(3). Pronotum with posterior margin weakly notched. Postmentum with a strong waist in posterior third
- 5(6). Frons rugose, with several transverse ridges in middle. Mandibles larger and less incurved apically (index Left mandible-length/Head-length to mandible-base 0.66-0.76)..... *viarum*
- 6(5). Frons with no transverse ridges, either smooth or only weakly wrinkled. Mandibles shorter and strongly incurved apically (index Left Mandible-length/Head-length to mandible-base 0.53-0.66)..... *macrocephalus*

2. *Anacanthotermes baluchistanicus* Akhtar  
(Figs. 79-81)

*Anacanthotermes baluchistanicus* Akhtar :

1972. Chaudhry and Ahmad, *Termites of Pakistan (Final Tech. Rep. PL 480 Proj.)*: 10. Chaman (Baluchistan, Pakistan). *Nomen nudum*.

1974. Akhtar, *Biologia* (Lahore), 20: 17-40. S, W, Holotype: S, in Zoology Dept., Panjab Univ., Lahore. Type-locality: Chaman (Baluchistan, Pakistan).

1974b. Akhtar, *Pakistan J. Zool.*, 6: 90.

1979. Akhtar, *Biologia* (Lahore), 25: 161, 162.

1988. Roonwal and Bose, *Occ. Pap. Rec. zool. Surv. India*, No. 111: 3, 4, 5-7, 11, 53, 54.

IMAGO : Unknown.

SOLDIER (Figs. 80, 81): Dimorphic. *Soldier Major* : Head reddish brown; squarish, sides subparallel with a weak depression in middle (length to mandible base 4.17, maximum width 3.53 mm); Y-suture present; with many moderately long hairs. Anteclypeus trapezoid. Postclypeus not well differentiated. Labrum wider than long, with many hairs all over, the

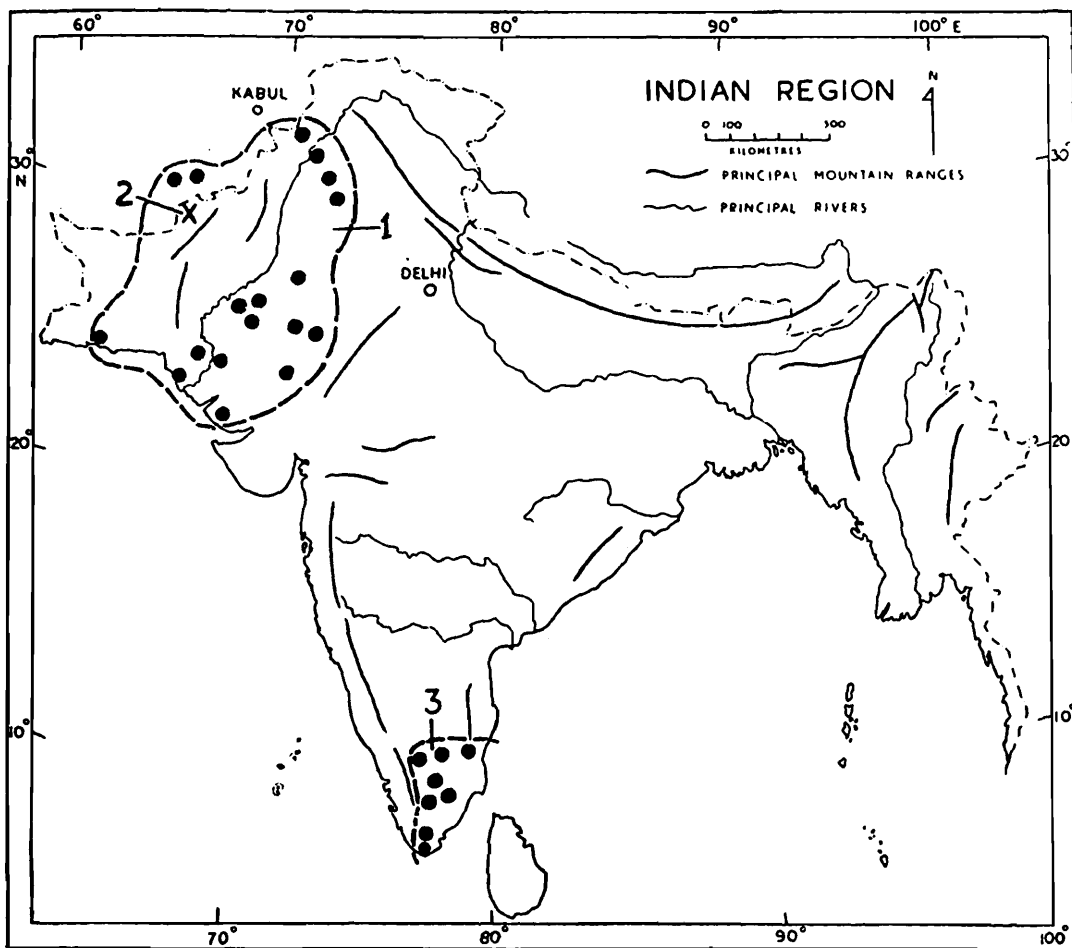

Fig. 79. Map of the Indian Region, showing distribution of the species of *Anacanthotermes*.  
1. *A. macrocephalus*. 2. *A. baluchistanicus*. 3. *A. viarum*.

anterior-ones longer. Antennae with 23 segments. Eyes and Ocelli small. Mandibles stout (length 2.71 mm), with well developed marginal teeth. Postmentum long (length 2.91, width maximum 1.02, minimum, 0.87 mm), flat, sides subparallel. Pronotum, weakly raised and convex anteriorly, posterior margin deeply notched in middle. Tarsi 4-joined.

*Soldier Minor* : Generally like soldier major but smaller; head length to mandible base 3.20, maximum head-width 2.91 mm). Antennae with 25 segments. Postmentum with wavy sides. Pronotum with only a weak notch on posterior margin.

WORKER (Fig. 80 E) : Not described by Akhtar, but mandibles illustrated; Mandibles with 2 marginal teeth (widely separated on left, and close together on right mandible).

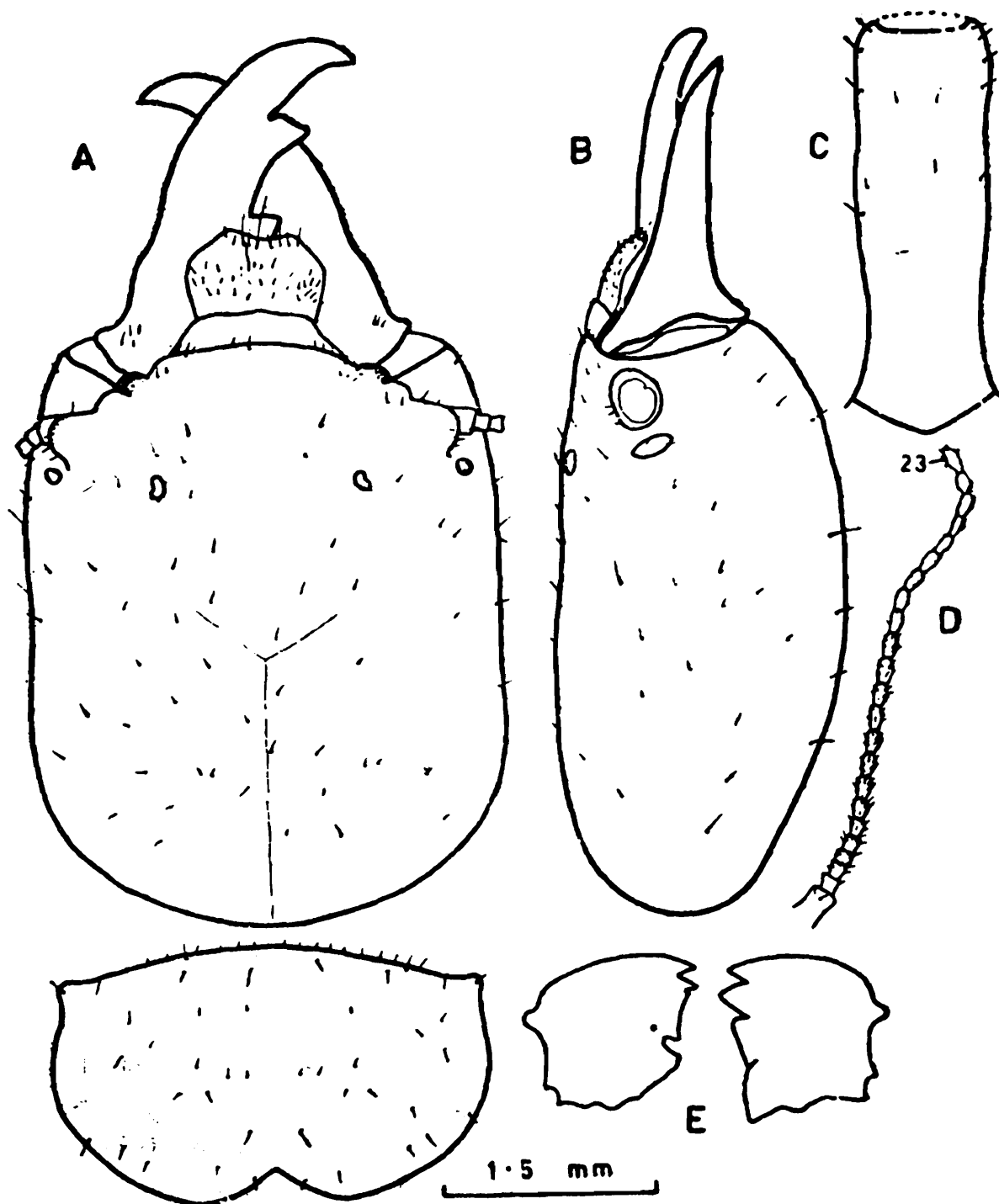

Fig. 80. *Anacanthotermes baluchistanicus*. Soldier Major (A-D) and Worker (E). (A) Head and pronotum, in dorsal view. (B) Head, in side view. (C) Postmentum. (D) Antenna (E) Worker mandibles (After Akhtar, 1974).

**Distribution** (Fig. 79) : PAKISTAN: Known only from the type-locality (Chaman, Baluchistan).

**Biology** : It attacks logs and makes longitudinal tunnels.

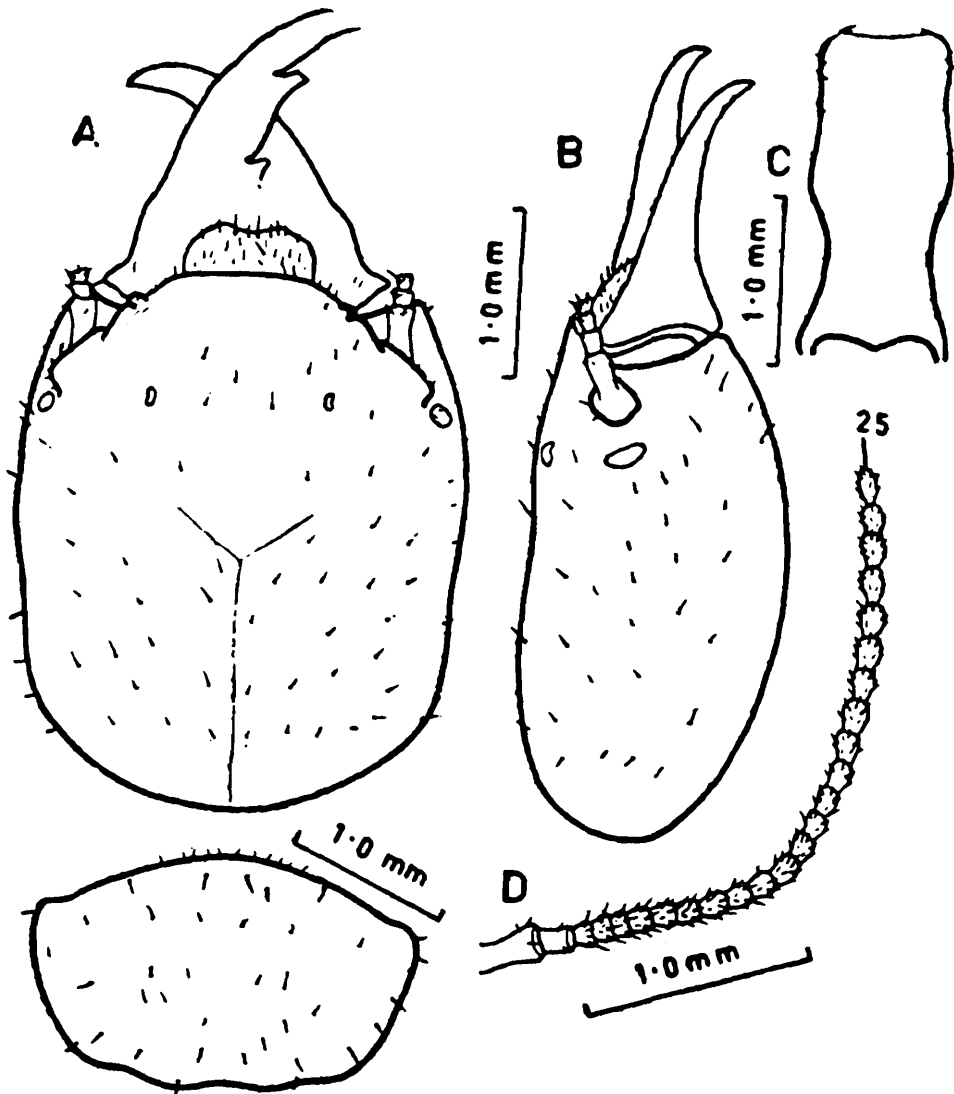

Fig. 81. *Anacanthotermes baluchistanicus*. Soldier Minor. (A) Head and pronotum, in dorsal view. (B) Head, in side view. (C) Postmentum. (D) Antenna. (After Akhtar, 1974).

### 3. *Anacanthotermes macrocephalus* (Desneux)

(Syn. *A. peshawarensis* Akhtar)

(North Indian Harvester Termite)

(Figs. 79, 82-86)

#### 1. *Hodotermes macrocephalus* Desneux :

1906. Desneux, *Ann. Soc. ent. Belg.*, 49(12) [1905] 344-348. Im, S and W. Holotype not selected, syntypes (Im, S, W) in AMNH and probably in Inst. Royal des Sciences naturelle de Belgique, Brussels. Type-locality: Sind (Pakistan): Karachi and vicinity and whole of Sind (both upper and lower; we restrict it to Karachi. [T.R. Bell, in Desneux, 1906, Ibid: 346-347.]

1909. Lefroy, *Indian Insect Life* Vol. 1: 120. Sind.

1914. Bugnion, *Bull. Mus. Hist. nat.*, 20(4): 175. Karachi (Pakistan) and Trichinopoly (S. India) [*Confuses H. viarum* Konig. of S. India with *H. macrocephalus* Desn. of Sind and regards them as conspecific. Trichinopoly examples must be *Anacanthotermes viarum*.]
1941. Beeson, *Ecology & Control Forest Insects in India* : 541. Punjab and Sind plains. (Reprinted ed., 1961: 416.)
2. *Hodotermes macrocephalus* Holmgren :
1960. Rao, *The Desert Locust in India*, New Delhi (I.C.A.R.): 286. Pasni reks (sand dunes) Baluchistan Coast, Pakistan). [No doubt Rao means '*macrocephalus* Desneux' and not Holmgren; Rao also wrongly puts it in the family "Calotermitidae" instead of Hodotermitidae.]
3. *Hodotermes (Anacanthotermes) macrocephalus* Desneux :
1911. Holmgren, *K. Sv. Vet. Akad. Handl.*, 46(6): 43; Pl. 1, Fig. 10, India.
1913. Holmgren, *K. Sv. Vet. Akad. Handl.*, 50(2): 36; Pl. 1, Fig. 2. Karachi (Sind).
1917. Holmgren and Holmgren, *Mem. Dept. Agric. India (Ent.)*, 5: 139. W. Sind ("Mile 120 on railway from Badin to Hyderabad").
1932. Kirby, *Univ. Calif. Publ. (Zool.)*, 37: 387-388, 444. Protozoa in gut.
1934. Margabandhu, *J. Bombay nat. Hist. Soc.*, 37(3): 701. Sind.
4. *Anacanthotermes macrocephalus* (Desneux) :
1944. Kirby, *Univ. Calif. Publ. (Zool.)*, 49(8): 186-187. Sargodha (Punjab, Pakistan). Protozoa in gut.
1949. Snyder, *Smiths. misc. Colls.*, 112: 62. India.
1953. Rattan Lal & Menon, *Catal. Indian Insects*, Pt. 27, *Isoptera* : 3. Sind; Punjab. [Also gives Ceylon, based on Bugnion, 1914, But Bugnion *did not* record it from Ceylon; and his record from S. India (Trichinopoly) was due to confusion with *A. viarum*, vide supra.]
1953. Roonwal and Pant, *Indian Forest Leafl. (Ent.)*, No. 121(3): 46. Pakistan (Punjab: Dipalpur, Montgomery Dist.; and Miranpur).
1955. Ahmad, *Biologia* (Lahore), 1(2): 210-212. Pakistan (Punjab, Sind, Baluchistan).
1960. Weidner, *Abh. u. Verh. naturwiss. Verein Hamburg*, (N.F.) 4 [1959]: 45 (map), 51 (Fig. B, soldier) and 56-57. SE. Afghanistan.
1961. Harris, *Termites. Their Recognition and Control* : 49, 107. Record from "north-east India" (p. 49) incorrect.
1962. Mathur and Thapa, *Indian Forest Leafl. (Ent.)*, No. 167: 4. Bikaner (W. Rajasthan); Pakistan (Punjab).
- 1962a, b. Gupta, *Rec. Indian Mus.*, 58 (3-4) [1960]: 169-194; and *Ibid.*: pp. 195-222. Bikaner and vicinity (W. Rajasthan). External morphology.
1964. Roonwal and Bose, *Zoologica*, (Stuttgart), 40(3) Heft (113): 9-12. India (W. Rajasthan) Pakistan and SE Afghanistan.

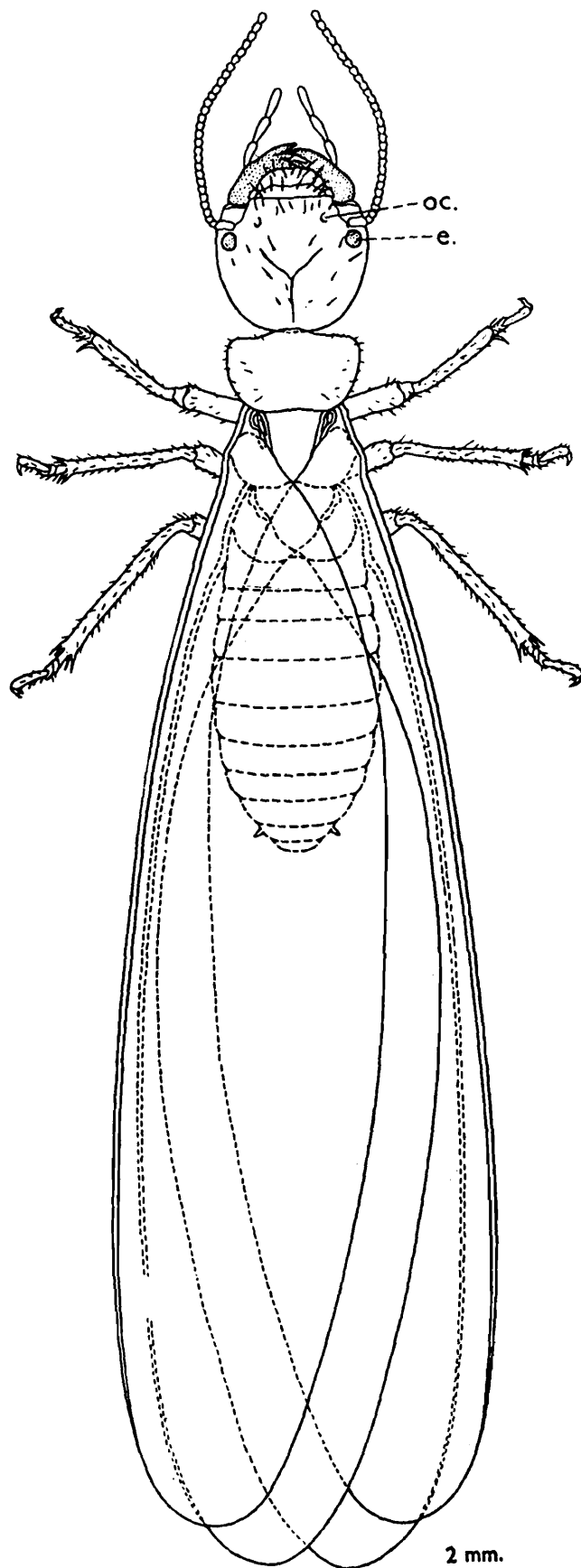

Fig. 82. *Anacanthotermes macrocephalus*. Imago, in dorsal view. e., eye; oc., ocellus.

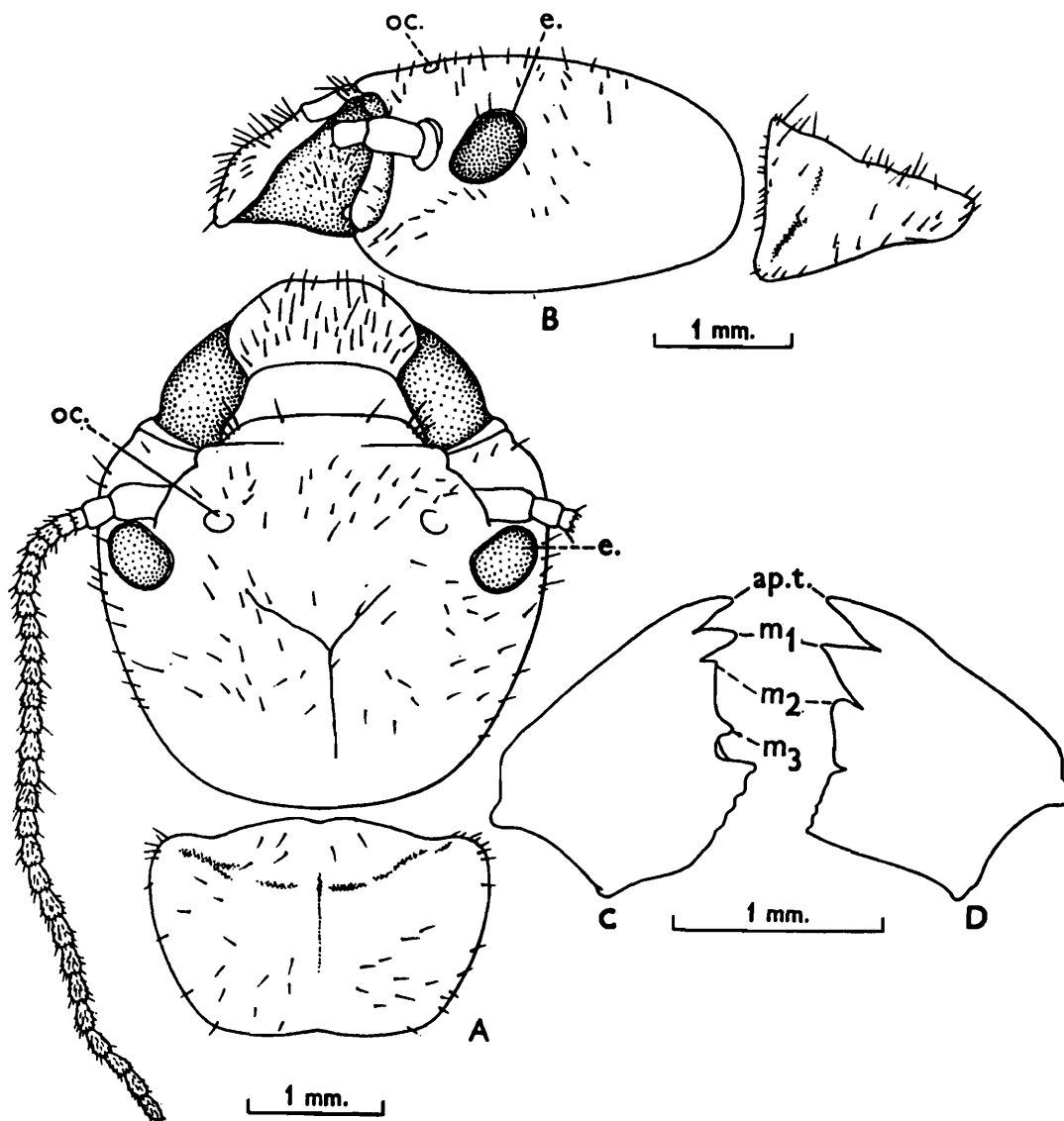

Fig. 83. *Anacanthotermes macrocephalus*. Imago. (A) Head and pronotum, in dorsal view. (B) Same, in side view. (C) Left mandible. (D) Right mandible. ap.t., apical tooth of mandible; e., eye; m1, m2, m3, 1st, 2nd and 3rd marginal teeth of mandibles; oc., ocellus.

1969. Roonwal and Bose, *Rec. zool. Surv. India*, 61(1963): 438.

1970. Roonwal, In *Biol. of Termites* Vol. 2. (Eds. Krishna and Weesner): 330-332.

1972. Roonwal and Rathore, *Annals arid Zone*, 11: 4-10. Jodhpur and vicinity.

1974. Akhtar, *Pakistan J. Zool.*, 6: 30-31. Pakistan.

1975a. Roonwal, In *Environm. Analysis of Thar Desert* : 400-401. Distribution.

1975b. Roonwal, *Z. angew. Ent.*, 78(4): 424-440. W. Rajasthan. Biology.

1976. Roonwal, *Zool. Jb.*, 103: 481-482. Distribution, biogeography.

- 1977a. Roonwal, In *Natural Resources of Rajasthan*: 377. W. Rajasthan.
- 1977b. Roonwal and Verma, *Rec. zool. Surv. India*, **72**: 433. Distribution.
1979. Akhtar, *Biologia* (Lahore), **25**: 161, 162.
1979. Roonwal, Verma and Thakur, *Proc. Indian natnl. Sci. Acad.*, (B) **45**: 123. Wing microsculpturing.
1982. Grassé, *Termitologia* Vol. 1 : 11, 17, 22, 31, 37, 39, 40, 44, 56, 58, 62, 63, 67, 69, 70.
1983. Roonwal, *Proc. Indian natnl. Sci. Acad.*, (B) **49**: 378. Wing microsculpturing.
1984. Weidner, *Anz. Schadlingskd.*, **57**: 6 Distribution.
1984. Bose, *Occ. Pap. Rec. zool. Surv. India*, No. 49: 72.
1986. Grassé, *Termitologia* Vol. 3 : 374, 375, 507, 611, 651, 692.
1988. Roonwal and Bose, *Occ. Pap. Rec. zool. Surv. India*, No.: 111 : 3, 4, 5-36, 53, 54.
5. *Anacanthotermes peshawarensis* Akhtar.
1972. Chaudhry and Ahmad, *Termites of Pakistan (Final Tech. Rep. PL 480 Proj.)* : 10. Pakistan (N.W.F.P. : Peshawar Bara). *Nomen nudum*.
- 1974a. Akhtar, *Biologia* (Lahore), **20**: 40-44. Holotype : S., in Zoology Dept., Punjab Univ. Lahore. Type-locality : Peshawar. *Syn. nov.*
- 1974b. Akhtar, *Pakistan J. Zool.*, **6**: 90.
1979. Akhtar, *Biologia* (Lahore), **25**: 161, 162.

IMAGO (Figs. 82-84) : Head yellow to brownish yellow, mandibles darker. Head and body moderately pilose. Total length with wings 27.2-27.5 mm; without wings 12.5-14.8 mm. Head subcircular, broader than long (maximum width 2.70-3.40, length to lateral base of mandibles 2.40-3.00 mm); broadest near base of antennae, posterior margin rounded. Fontanelle absent. Eyes large, suboval, the side facing antenna with substraight margin. Ocelli small, almost flush with head surface. Antenna with 26-29, mostly 27, segments (Afghanistan examples have only 24 segments, Weidner 1960); segment 1 longest; 2 less than half of 1; 3-5 subequal and shortest. Frons weakly striated. Anteclypeus large, apilose. Postclypeus narrower and with a few hairs near anterior margin. Labrum much broader than long, sides bulging out in middle; anterior margin substraight with a weak medial depression, with several longish hairs on anterior margin and body. Left mandible with three marginal teeth; 2nd very small and widely separated from 3rd; right mandible with the two marginals close together. Pronotum narrower than head, weakly saddle-shaped; anterior margin convex with a small median notch; posterior margin weakly convex with a small median notch. Legs long, stout and pilose; tarsi

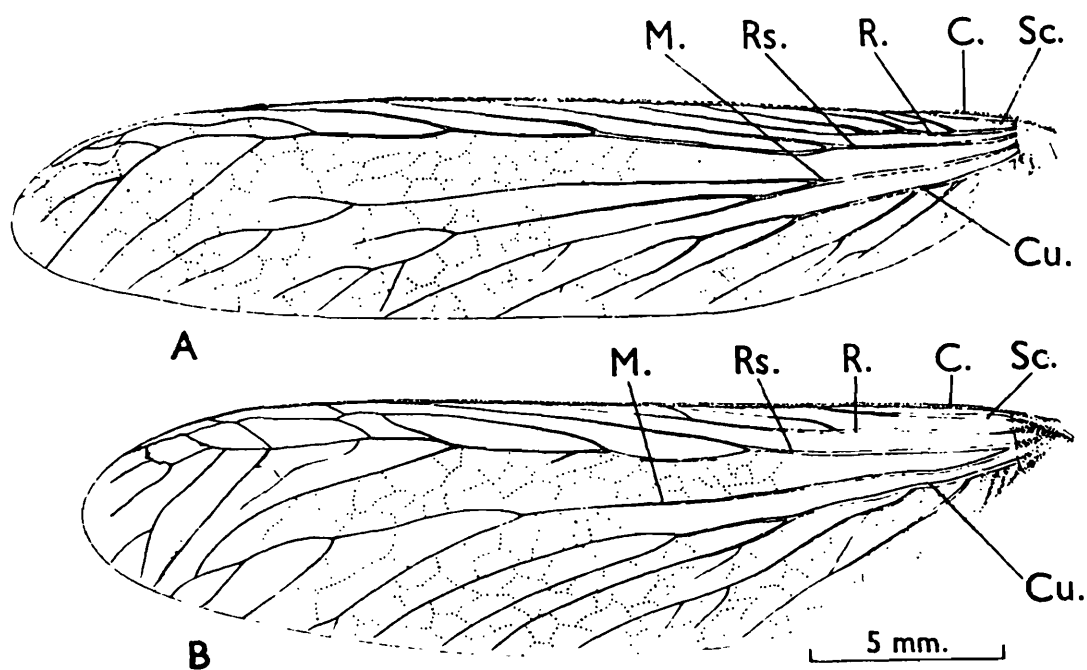

Fig. 84. *Anacanthotermes macrocephalus*. Wings. (A) Forewing. (B) Hindwing. C., costa; Cu., cubitus; M., media; R., radius; Rs., radial sector; Sc., subcosta. (After Roonwal & Bose, 1964).

4-jointed; apical tibial spur formula 3: 4: 4. Wings reticulated. Wing microsculpturing consists of numerous papillae ( $3-6 \mu\text{m} \times 2-4 \mu\text{m}$ ) and pimpules ( $2-3 \mu\text{m} \times 2-3 \mu\text{m}$ ); no micrasters (Roonwal and Rathore 1978, Roonwal, Verma and Thakur 1979a, Roonwal 1983c). In both wings the roots of principal veins lying within the basal scale. In forewing, C well marked, Sc short, R 4-branched, Rs 6-branched, M 3-branched, Cu with 4 main branches, A absent. Hindwing generally like forewing. Cerci one-jointed, small, subconical, 0.28-0.30 mm long. Styli short, one-jointed, 0.08-0.10 mm long, present in both sexes.

**SOLDIER** (Fig. 85) : Sparsely pilose. Head yellow to brownish yellow. Total length with mandibles 10.5-15.3 mm. Head subsquarish, slightly longer than broad (length to lateral base of mandibles 3.00-4.90; maximum width 2.70-4.56 mm); broadest posteriorly; posterior margin rounded. Fontanelle absent. Frons either smooth or only weakly wrinkled. Eyes small, subcircular. Ocelli as small, subround spots. Antennae with 25-31 segments; segment 1 longest; 2 about half of 1; 3 subequal to 2; 4 smallest. Anteclypeus a narrow, trapezoidal, apilose, hyaline strip. Postclypeus not well differentiated; with a few hairs anteriorly. Labrum broad, subrectangular, much broader than long; with several hairs on anterior part and on body; anterior angles rounded; anterior margin substraight, with a slight

median depression. Mandibles long, stout and incurved at apex; each with two large marginal teeth. Postmentum club-shaped, broadest in anterior third; anterior margin substraight to wavy; posterior margin straight to weakly convex. Pronotum weakly saddle-shaped, much broader than long (width 2.00-3.23; length 0.98-1.80 mm); anterior margin convex and with a weak median notch; posterior margin convex with a strong median notch; a few hairs on margins and body. Mesonotum much broader than long; sides straight; posterior margin slightly convex. Metanotum with straight sides; posterior margin weakly convex. Legs long, stout, sparsely pilose; tarsi 4-jointed; apical tibial spur formula 3 4 : 4. Cerci short, one-jointed, 0.18-0.25 mm long. Styli one-jointed, 0.10-0.15 mm long.

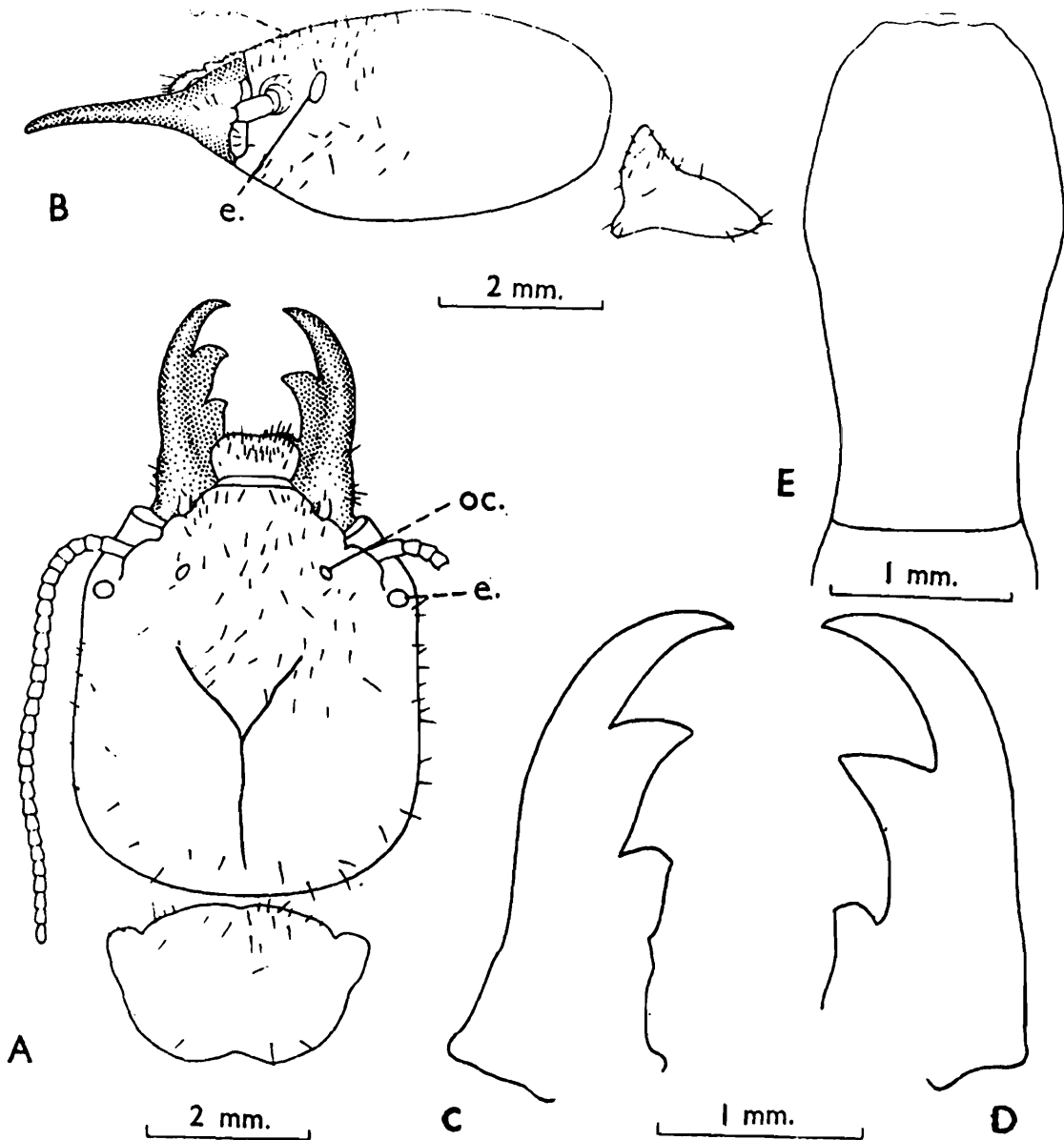
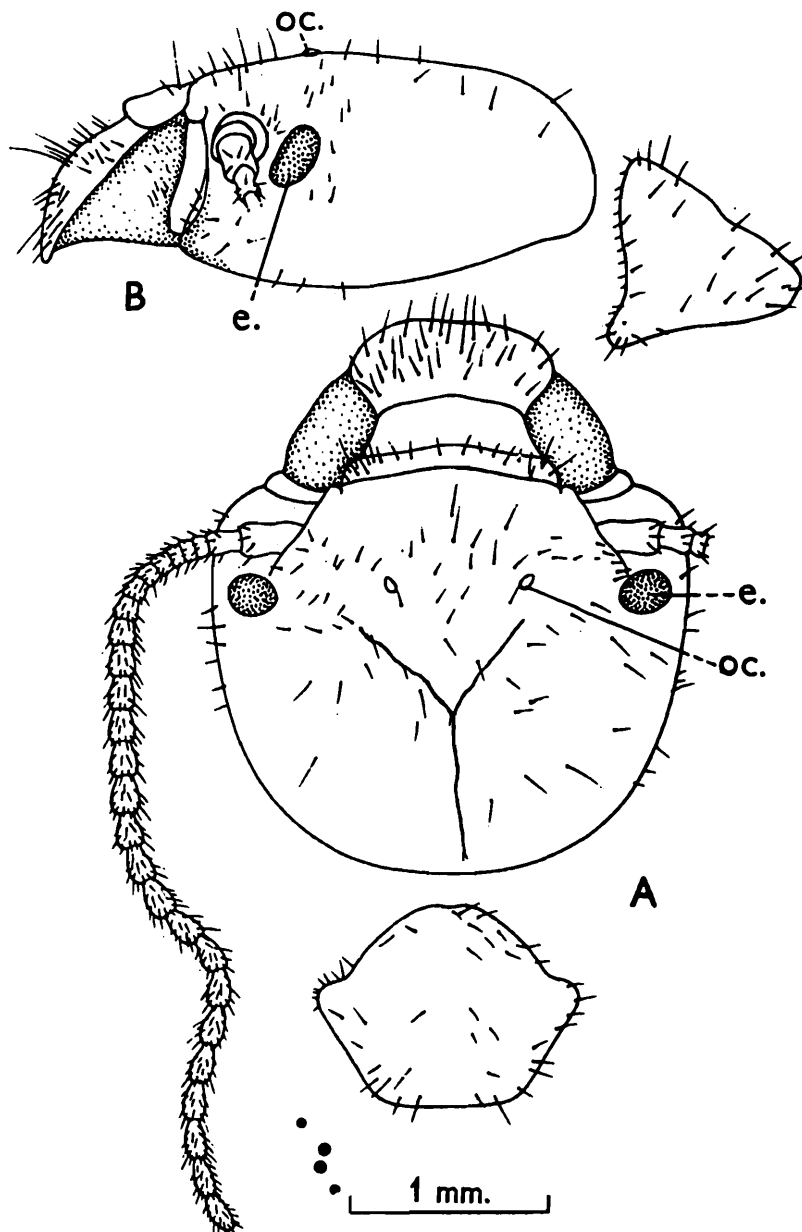

Fig. 85. *Anacanthotermes macrocephalus*. Soldier. (A) Head and pronotum, in dorsal view. (B) Same, in side view. (C) Left mandible. (D) Right mandible. (E) Postmentum. e., eye; oc., ocellus.

**WORKER (Fig. 86) :** Head brownish yellow. Total length 6.1-10.6 mm. Head subsquarish, somewhat broader than long (width 1.6-3.3, length 1.40-2.85 mm). Fontanelle absent. Eyes round, moderately large (diameter 0.4 mm). Ocelli very small. Antennae with 25-31 segments; 5 smallest. Anteclypeus small; postclypeus very narrow, not always distinct. Labrum and mandibles as in imago. Pronotum much narrower than head. Sparsely pilose, subtrapezoidal, strongly convex anteriorly; much broader than long (length 0.65-1.00, width 0.90-1.75 mm); anterior margin strongly convex, with a weak median notch; posterior margin substraight without a median notch. Mesonotum narrower than pronotum; much broader than long, with a few rows of hairs near the convex posterior margin. Metanotum much broader than long; with rows of hairs near posterior margin. Legs long,



**Fig. 86.** *Anacanthotermes macrocephalus*. Worker. (A) Head and pronotum, in dorsal view. (B) Same, in side view. e., eye; oc., ocellus.

slender; tarsi 4-jointed; apical tibial spur formula 3 : 4 4. Cerci short, (0.15-0.20 mm long, faintly 3-jointed, vide Gupta 1962b). Styli short, one-jointed, 0.13-0.15 mm long.

*Distribution* (Fig. 79) The arid regions of Western India (Rajasthan and Gujarat), Pakistan and SE Afghanistan, as follows :

INDIA *Rajasthan* : Western desert area : Districts of Bikaner, Jaisalmer, Barmer and Jodhpur (east to Borunda, 26°20'N 73°30'E; 70 km of Jodhpur). *Gujarat* : Kutch area (Chavda, 26 km from Bhuj). PAKISTAN: *Punjab*: Districts of Montgomery Shahpur and Mianwali. *Sind*: Karachi, Hyderabad, SE of Hyderabad between Hyderabad and Badin (mile 120 on railway); almost the whole of Sind. *Baluchistan* : Quetta, Sariah and Chaman. Also Pasni (on coast). *N.W.F.P.* : Peshawar (*peshawarensis*). AFGHANISTAN SE part (1045-1240 m) : Char Safa between Kalat and Kandahar.

For more details, see Roonwal and Bose (1988).

*Biology* : *A. macrocephalus* is a pest of grasslands and also attacks wheat, maize and jute bags in storage; also the bark of some trees. It lives underground in thin, extensive galleries, studded with bulges or chambers for food storage. It builds low conical mounds of loose, granular earth, about 60-250 mm high and 100-800 mm in basal diameter. Nesting occurs underground. Parties of workers (only rarely accompanied by soldiers) forage out on the ground, mostly at night. Swarming (in Rajasthan) occurs at night mostly during August. In swarming populations, males predominate over females in the ratio of 9: 7. Eggs are laid about 10-16 days after swarming, A female lays 5-18 eggs in first batch. Eggs are gathered together in masses, and communal brood-care occurs.

#### 4. *Anacanthotermes vagans* (Hagen)

(Fig. 87, 88)

##### 1. *Hodotermes vagans* Hagen :

1858. Hagen, *Linn. Ent.*, 12: 88. Im. W. Pl. 2, Figs. 18 and 19 (Im). Holotype : Im, in Natural History Museum, Vienna. Type-localities: South Iran : Shiraz; and Karak Is. in Persian Gulf.

1923. Silvestri, *Trans. ent. Soc. Lond.*, 1923: 261. Raz, NE of Baghdad (Iraq).

##### 2. *Hodotermes (Anacanthotermes) vagans* Hagen :

1905. Jacobson, *Ann. Mus. Zool. Akad. imp. Sci. St. Petersburg*, 9 (1904): 66.

1911. Holmgren, K. *Sv. Vet. Akad. Handl.*, **46**(6): 43.

3. *Anacanthotermes vagans* (Hagen) :

1949. Snyder, *Smithson, misc. Colls.*, **112**: 63. Persia.

1958. Weidner, *Ent. Mitt. zool. Staatsmus. und zool. Mus. Hamburg*, No. 17: 6-8. Iraq.

1960. Weidner, *Abh. u. Verh. naturwiss. Vereins Hamburg*, **1** (1959): 45, 49-53. Iraq, Iran, Afghanistan.

1970. Harris, In *Biology of Termites* (Eds. Krishna and Weesner) Vol. 2: 301.

1972. Chaudhry and Ahmad, *Termites of Pakistan (Final Tech. Rep. PL 480 Proj.)*: 19. Pakistan (Baluchistan).

1974. Akhtar, *Pakistan J. Zool.*, **6**: 90. Pakistan.

1979. Akhtar, *Biologia* (Lahore), **25**: 161, 162, 163-169.

1967. Harris, *Proc. R. ent. Soc. Lond.*, **36** (5-6) : 80, 81, 83, 84.

1983. Chhotani and Bose, In : *Fauna of Saudi Arabia* Vol. 5 : 122, 123.

1984. Weidner, *Anz. Schadlingskd.*, **57**: 4-6. Distribution.

1988. Roonwal and Bose, *Occ. Pap. Rec. zool. Surv. India*, No. 111: 4, 10, 11, 36-40, 53, 54.

**IMAGO** (Fig. 87 a-c) : Head and thorax brownish red; rest paler. Total length with wings 24-26, without wings 11-13 mm; maximum wing expanse 42 mm. Head large, round, slightly narrowing near eyes; length to mandible-base 2.37-2.54, maximum width 2.8-3.07 mm; epicranial suture well marked. Eyes black, well developed; maximum diameter 0.47-0.59 mm. Ocelli present as round fairly large yellowish spots well raised from surface (interpreted by Weidner as 'antennal spots'). Antennae thin, shorter than head, with 24-27 segments (mostly 25); segment 3 smallest (but in 26-segmented antennae, 3 longer than 4). Labrum rounded, almost circular. Pronotum narrower than head (2.05-2.33 mm wide), width about twice the length; front half bent; anterior margin strongly convex; sides narrowing posteriorly; posterior margin without a deep median notch. Legs with no lateral spines. Wings long and narrow, reticulated. Forewing (length 20-23, width 4.2-4.8 mm) with short Sc; R reaching the middle of C, and giving 2 or more branches; Rs with 5 branches to C and 3 to M; M with 2 main branches; Cu with 9 branches; anal absent. Hindwing almost like forewing; a weak anal present. Abdomen ovoid, somewhat wider than thorax. Cerci small, conical. Styli very small, present in both sexes.

**SOLDIER** (Fig. 87 d, e) : Head reddish brown, smooth, with a few hairs; mandibles blackish; rest paler. Total length with mandibles c 14 mm; size varies considerably. Head subrectangular (length with mandibles 4.6-6.5, to

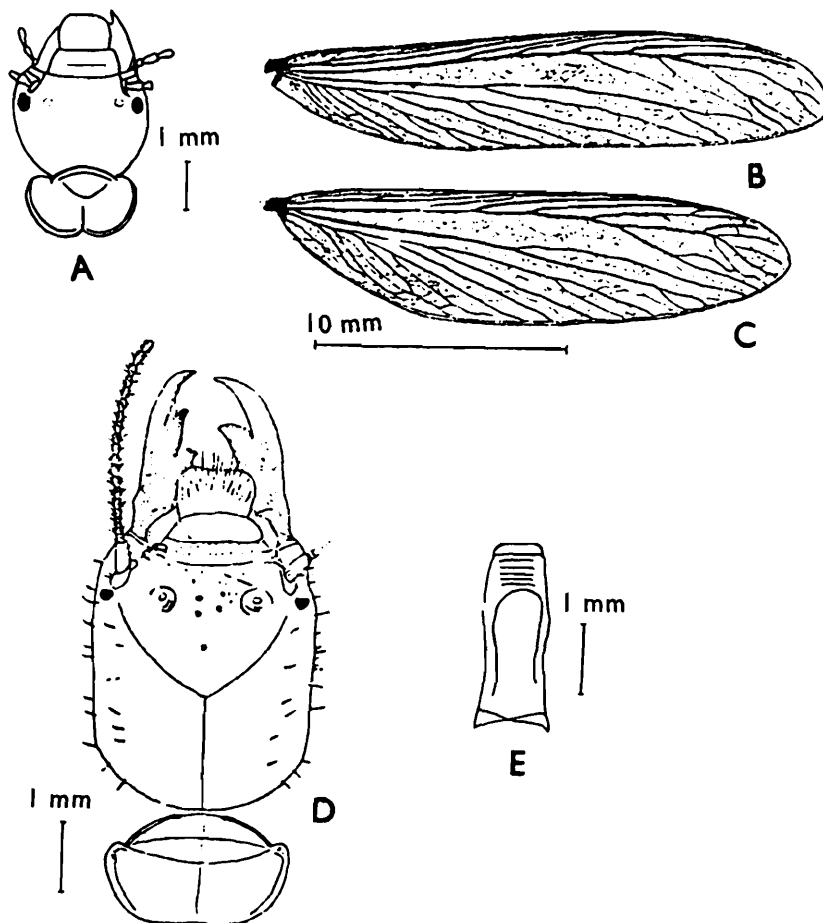

Fig. 87. *Anacanthotermes vagans*. (A) Imago, head and pronotum. (B) Forewing. (C) Hindwing. (D) Soldier, head and pronotum. (E) Same, postmentum. (After Weidner, 1960).

base of mandibles 2.91-4.40, maximum width 2.50-3.78 mm); posterior margin rounded; epicranial suture well marked. Eyes blakish, smaller than in imago; length about twice the width. Ocelli small, rounded, raised from surface (interpreted by Weidner as 'antennal spots'). Mandibles large, pointed and incurved at apex; length of left mandible 2.5 mm; with two large, pointed marginal teeth. Labrum large, subrectangular, narrowing posteriorly. Clypeus strip-like. Antennae thin, shorter than head; number of segments not known (but in his figure, Weidner, 1960, shows a broken antenna with 22 segments), 24-26 segmented vide Akhtar 1979. Postmentum band-like, with subparallel sides only very weakly incurved (cf. *A. macrocephalus*, etc.). Pronotum a little narrower than head, (width 1.92-3.22 mm); weakly saddle-shaped (the anterior end upcurved); anterior margin strongly convex, not notched; posterior margin not notched. Abdomen translucent, with the gut contents showing through.

**WORKER** : Head orange; rest pale reddish yellow; eyes and mandibles darker. Total length 6-10 mm. Head round, almost ovoid. Eyes dark

brown. Ocelli small, marked by dark spots. Antennae with 24-25 segments. Pronotum saddle-shaped; divided by a transverse groove into two halves. Cerci present; styli short, pointed.

**Distribution** (Fig. 88) : Southern Iraq in the west, almost the whole of Iran (especially common in south), Kuwait (Arabia), east to southern Afghanistan and southern Pakistan (Baluchistan). The Pakistan localities are : Surkhab forest (Quetta-Pishin District), Chaman, Mastung, Loralai, Notundi (Noshki District) and Ziarat.

**Biology** : Little is known of its biology. The species prefers arid areas, and may go up to about 2450 m altitude. It lives underground in narrow tunnels, and builds low amorphous mounds of granular, excavated earth. It eats grasses and also attacks wooden poles, and woodwork in houses.

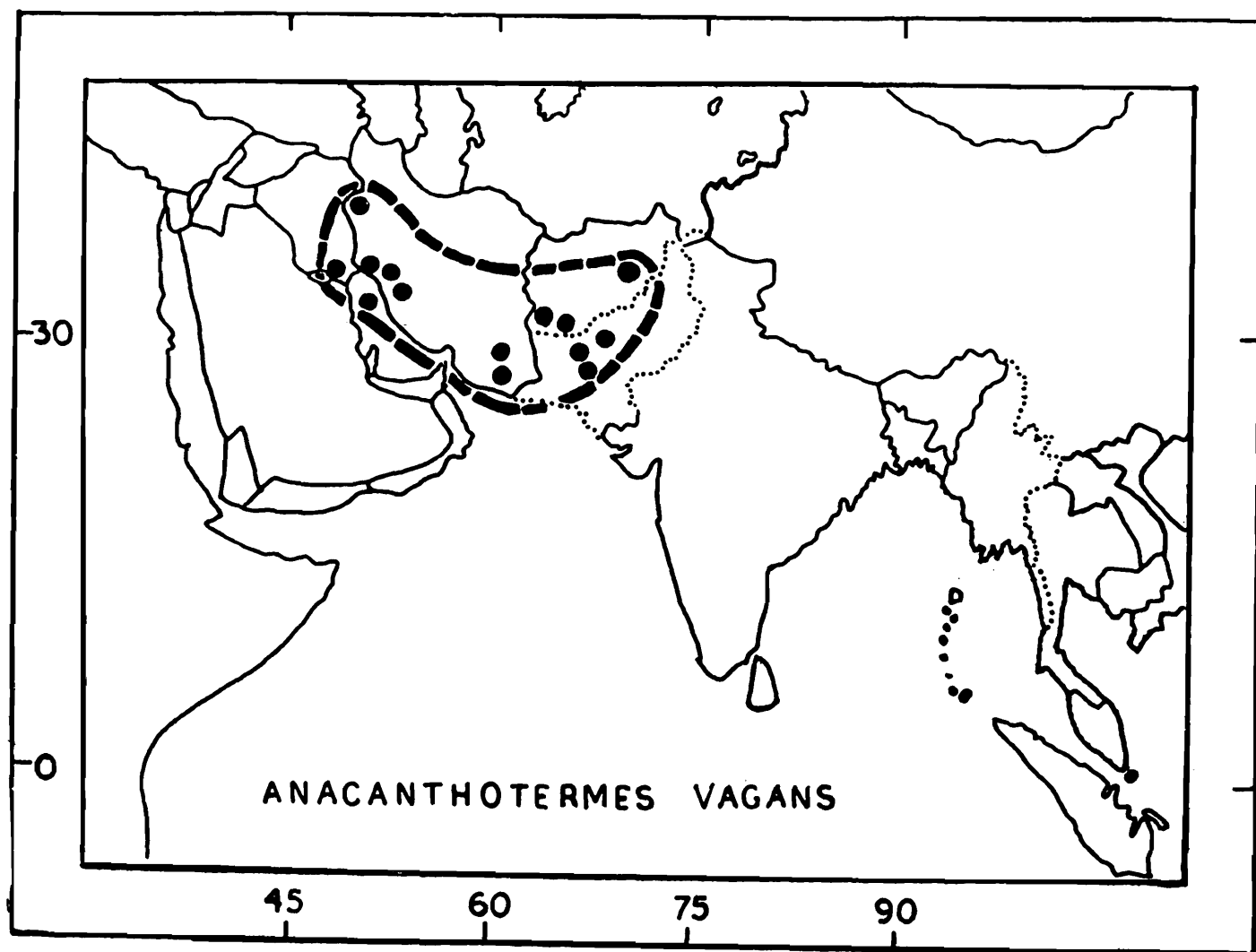

Fig. 88. Map of West and South Asia showing the geographical distribution of *Anacanthotermes vagans*.

**5. *Anacanthotermes viarum* (König) (nec Smeathman)**  
 (Syns. *Anacanthotermes koenigi* Holmgren and Holmgren; and *A. rugifrons*  
 Mathur and Sen-Sarma.)  
 (South Indian Harvester Termite)  
 (Figs. 79, 89-93)

1. *Termes viarum* König :

1779. König, *Beschr. berlin. Ges. naturf. Freunde*, 4: 24 (W. only) Pl. 1, Figs. 12-14 (W).  
 König's material not traceable. Neotypes : Designated by Roonwal & Bose; in  
 ZSI, Calcutta. Type-locality: (Tamil Nadu, S. India) Coimbatore on basis of  
 neotype mentioned above.

2. *Hodotermes viarum* (König) :

1858. Hagen, *Linn. Ent.*, 12: 90. "Trankebar" (= Tranquebar, Tamil Nadu).

1911. Holmgren, *K. Sv. Vet. Akad. Handl.*, 46(6) : 43. Not identifiable; suggests  
 relegating it to "species negligendae"

1912. Fletcher, *Agric. J. India*, 7(3): 224 (Figs. 1, S. head). India.

1914. Bugnion, *Bull. Mus. Hist. nat.*, 20(4): 175. (Confuses *H. viarum* and *H.*  
*macrocephalus*, regarding them as conspecific.)

1920. Fletcher, *Proc. 3rd ent. Mtg. (Pusa 1919)*, 1: 314. Coimbatore.

1920a. De Mello, *Proc. 3rd ent. Mtg.*, (1919, Pusa), 3: 1010-1019. Protozoa in gut.

1920a. De Mello, *Ann. Sci. Acad. Polytec. do Porto*, Lisbon, 14: 44-48. Protozoa in gut.

1921. Fletcher, *Rept. Proc. 4th Ent. Mtg. (Pusa, 1921)* : 330; and Pl. LII, Figs. 12-14.  
 (opp. p. 312). [English translation of König's paper of 1779.]

1932. Kirby, *Univ. Calif. Publ. (Zool.)*, 37: 407. Protozoa in gut.

1934. Margabandhu, *J. Bombay nat. Hist. Soc.*, 37(3): 701. Coimbatore (S. India).

3. *Hodotermes (Anacanthotermes) viarum* (König) :

1913. Holmgren, *K. Sv. Vet. Akad. Handl.*, 50(2) : 35, footnote. Regards it as  
 conspecific with *A. macrocephalus* "on geographical grounds", but adds that the  
 species is not morphologically identifiable and should be removed from literature.

4. *Anacanthotermes viarum* (König) :

1942. De Mello and G. Monterio, *Argu. Esc. med. Cirurg., Nova Goa*, (A), Fasc. 18,  
 pp. 1-14. Coimbatore, Protozoa in gut.

1944. Kirby, *Univ. Calif. Publ. (Zool.)*, 49(8): 186-187. Coimbatore, Protozoa in gut.

1949. Kirby, *Univ. Calif. Publ. (Zool.)* 45(5): 381. Protozoa in gut.

1949. Snyder, *Smithson. misc. Colls.*, 112: 63. S. India.

1953. Rattan Lal and Menon, *Catal. Indian Insects*. Pt. 27. *Isoptera* : 4. S. India (Tranquebar and Coimbatore). (Also gives Ceylon, based on Bugnion, 1914, but the latter author did *not* record it from Ceylon).
1953. Roonwal and Pant, *Indian Forest Leafh. (Ent.)*, No. 121(3): 46. Coimbatore (S. India).
1970. Roonwal, In *Biol. of Termites* (Eds. Krishna and Weesner), Vol. 2: 332.
1977. Chhotani, *Proc. 8th int. Congr. Int. Un. Study soc. Ins.* (Wageningen): 116. Sri Lanka. (Species not mentioned but presumably *A. viarum*.)
1983. Chhotani and Bose, In *Fauna of Saudi Arabia*, Vol. 5: 123.
1984. Bose, *Occ. Pap. Rec. zool. Surv. India*, No. 49: 72, 74.
1984. Weidner, *Anz. Schadlingskd.*, 57: 5. Sri Lanka (based on Chhotani, 1977, supra).
1988. Roonwal and Bose, *Occ. Pap. Rec. zool. Surv. India*, No. 111: 3, 4, 10, 11, 12, 41-53, 54.
5. *Hodotermes (Anacanthotermes) koenigi* Holmgren and Holmgren :
1917. Holmgren and Holmgren, *Mem. Dept. Agric. India (Ent.)*, 5: 138-139. cotypes : In AMNH and National Mus. Nat. Hist., Stockholm. Type-locality : Coimbatore (S. India).
1934. Margabandhu, *J. Bombay nat. Hist. Soc.*, 37(3): 701. Coimbatore.
6. *Hodotermes kőnigi* Holmgren :
1959. Rattan Lal and Menon, *Catal. Indian Insects*, Pt. 27 (*Isoptera*): 3. Coimbatore.
7. *Anacanthotermes rugifrons* Mathur and Sen-Sarma :
1958. Mathur and Sen-Sarma, *Entomologist* (1958) 91 (1146) : 233-241 (S, W.), Figs. 1 and 2. Holotype : S, in FRI, Dehra Dun. Type-locality : Pallayamcottah, lat. 08.04 N., long. 77.44 E. (Tinnevely [Tirunelveli] District, Tamil Nadu, India).
1970. Roonwal, In *Biol. of Termites* (Eds. Krishna and Weesner), Vol. 2: 332.
1983. Chhotani and Bose, In *Fauna of Saudi Arabia*, Vol. 5: 123.
1984. Bose, *Occ. Pap. Rec. zool. Surv. India*, No. 49: 74. (Treated it as conspecific with *A. viarum*)
8. *Species named "viarum" but status doubtful*  
(vide Hagen 1958, *Linn. Ent.*, 12: 93-94; and Snyder 1949, *Smithson. misc. Colls.*, 112: 351):
1781. *Termes viarum* Smeathman, *Philos. Trans. roy. Soc. Lond.*, 71: 189, S, and W. Camerankoes (Kamaranka) River, Sierra Leone (W. Africa).
- 1858a. *Hodotermes viarum* (Smeathman), Hagen, *Linn. Ent.*, 12: 93-94. (Says status doubtful, and the type seen by him in the Banks Collection is not *Hodotermes* but a *Termes*!)
- 1858b. *Hodotermes viarum* (Smeathman), Hagen, *Catal. Neuropt. Insects Brit. Mus.*, London, Pt. 1, Termitina : 14, No. 6. W.

1900. *Hodotermes viarum* (Smeathman), Sjstedt, *K. Sv. Vet. Akad. Handl.*, 34(4) : 27. (Same remarks as for Hagen, 1858a, supra.)
1911. *Hodotermes viarum*, Holmgren, *K. Sv. Vet. Akad. Handl.*, 46(6): 43. (Says *H. viarum* Smeathman are not identifiable and should be regarded as "species negligendae".)

### *Note on nomenclature*

König's (1779) description of the worker of his *Termes viarum* was inadequate, but his illustrations (Pl. 1, Figs. 12-14) of workers (reproduced in Fletcher 1921, Pl. LII, Figs. 12-14) are excellent and the insect is undoubtedly a hodotermitid. Some authors regard the name *viarum* as unidentifiable, (a *neotype*, has been designated by Roonwal and Bose, in press); we consider the species *viarum* as quite recognisable and accept the name as valid. There is a single *Anacanthotermes* species in South India, the two described later, e.g., *koenigi* Holmgren and Holmgren 1917, and *rugifrons* Mathur and Sen-Sarma 1958 being junior synonyms. The *viarum* of Smeathman (1781) from Sierra Leone (W. Africa) is unidentifiable (vide Hagen 1858a, p. 93, and Snyder 1949, p. 351).

IMAGO (Figs. 89, 90) : Head creamish yellow to golden brown, antennae paler distally. Sparsely pilose. Total length with wings 27.5-30.0, without wings 14.4-15.4 mm. Head rounded, a little broader than long (length to mandible-base 2.70-2.90, maximum width 3.20-3.42 mm). Fontanelle absent. Eyes fairly large (maximum diameter 0.63-0.70 mm), suboval. Ocelli small (interpreted by some authors as 'antennal spots'). Antennae with 29-31 segments, segment 5 smallest. Anteclypeus strip-like, anterior margin projected in front medially. Postclypeus not well differentiated. Labrum broad, flap-like, broader than long. Left mandible with an apical and 3 marginal teeth; 2nd marginal very small and separated by a wide margin from 3rd. Right mandible with an apical and 2 marginal teeth and a small subsidiary tooth at anterior basal margin of 1st marginal. Pronotum narrower than head; posterior margin substraight, with a weak median depression; anterior margin bulged forward and without a median notch. Legs long, strong; tarsi 4-segmented; apical tibial spur formula 3: 4: 4. Wings long, narrow. In forewing roots of all principal veins arising within scale. C long, well marked; Sc small; R arising jointly with Rs and separating from it inside scale; R 3-branched; Rs many-branched; M simple

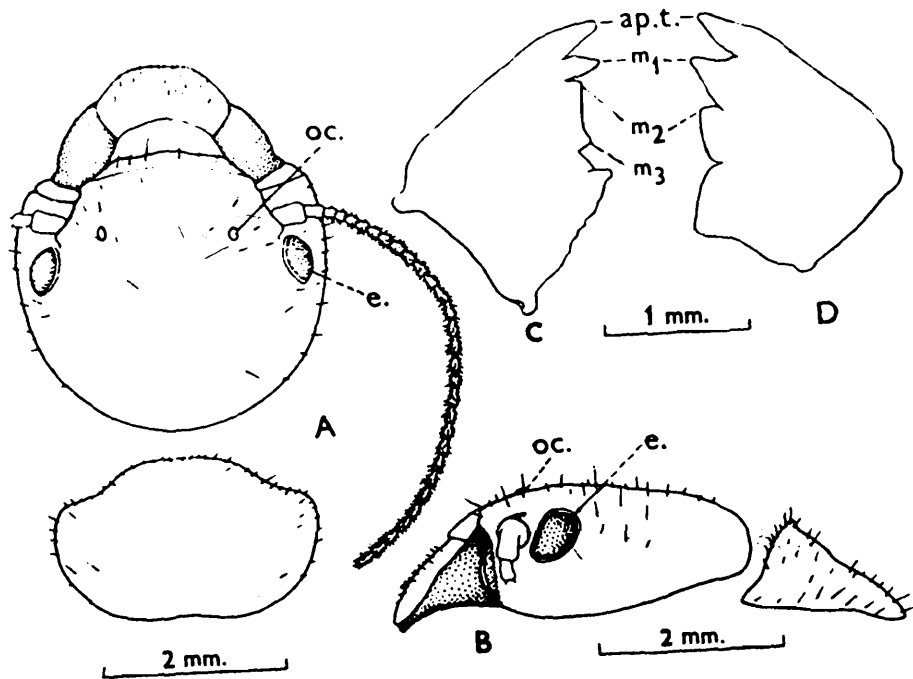

Fig. 89. *Anacanthotermes viarum*. Imago. Coimbatore, S. India. (A) Head and pronotum, in dorsal view. (B) Same, in side view. (C) Left mandible. (D) Right mandible. ap. t., apical tooth; e., eye; m1, m2, m3, 1st 2nd and 3rd marginal teeth of mandibles.

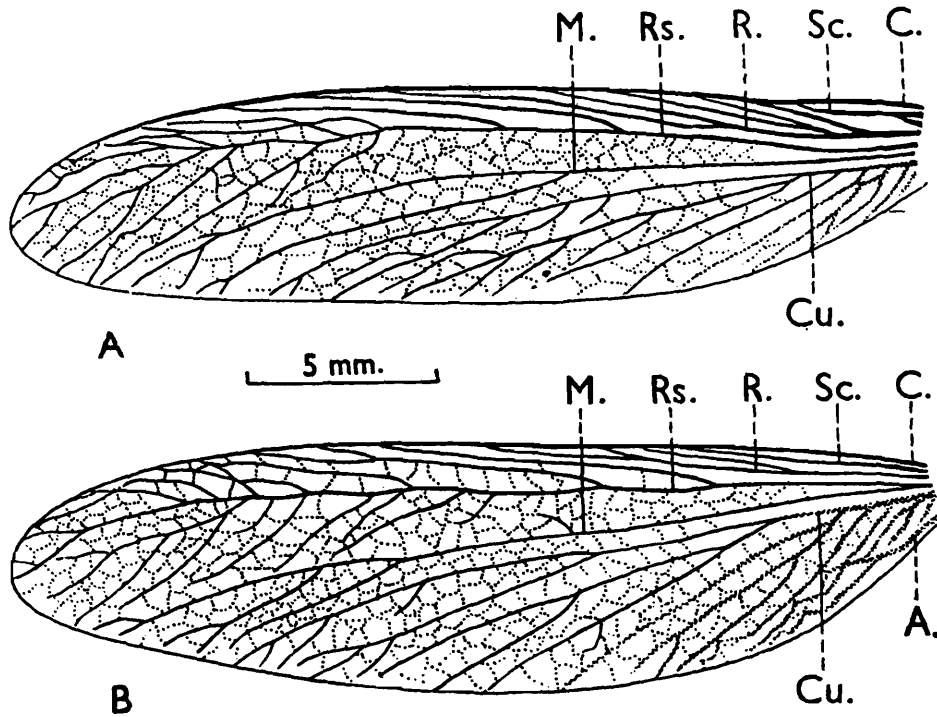

Fig. 90. *Anacanthotermes viarum*. Coimbatore S. India. (A) Left forewing. (B) Left hindwing. A, anal; C., costa; Cu., cubitus; M., media; R., radius; Rs., radial sector.

2-branched, Cu 8-branched; anal small, unbranched. In hindwing C long, Sc small; R arising separately from Rs outside scale, and 3-branched; Rs arising jointly with M inside scale, and 7-branched; M simple, 3-branched; Cu weak, 7-branched; anal 2-branched, small. Abdomen elongate-oval. Cerci and styli one-jointed, small.

**SOLDIER** (Fig. 91, 92) : Head golden to reddish yellow, posteriorly brownish. Lightly pilose. Size range wide; total length with mandibles 8.0-17.8 mm. Head subsquarish, a little longer than wide (length to

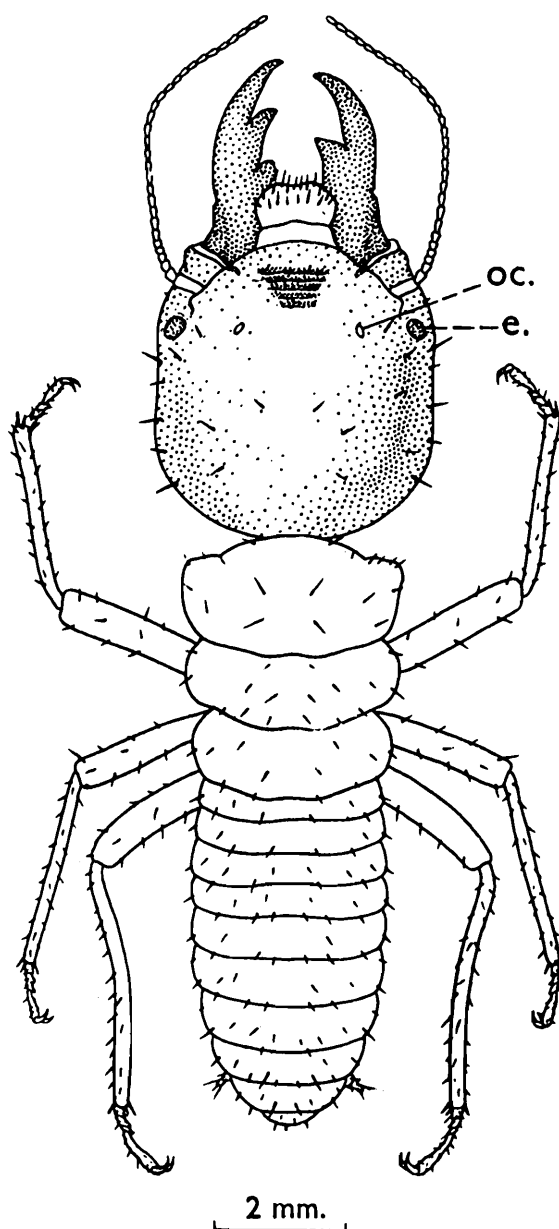

Fig. 91. *Anacanthotermes viarum*. Coimbatore, S. India. Neotype. Soldier, in dorsal view.  
e., eye; oc., ocellus.

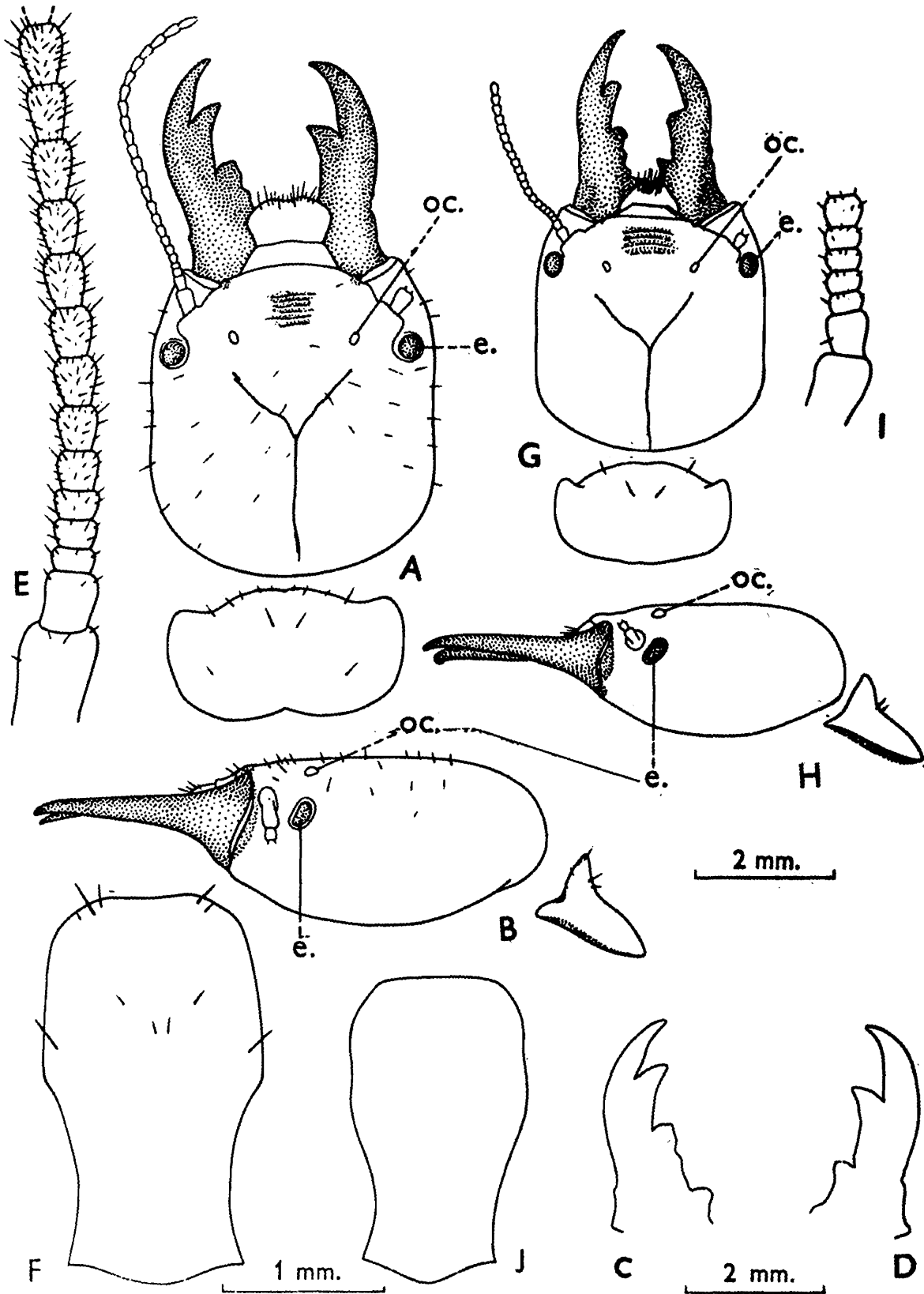

Fig. 92. *Anacanthotermes viarum*. Coimbatore, S. India. Soldiers. (A-F) Large soldier. (A) Head and pronotum, in dorsal view. (B) Same, in side view. (C) Left mandible. (D) Right mandible. (E) Basal part of antenna. (F) Postmentum. (G-J) Small soldier. (G) Head and pronotum, in dorsal view. (H) Same, in side view. (I) Basal part of antenna. (J) Postmentum. e., eye; oc., ocellus.

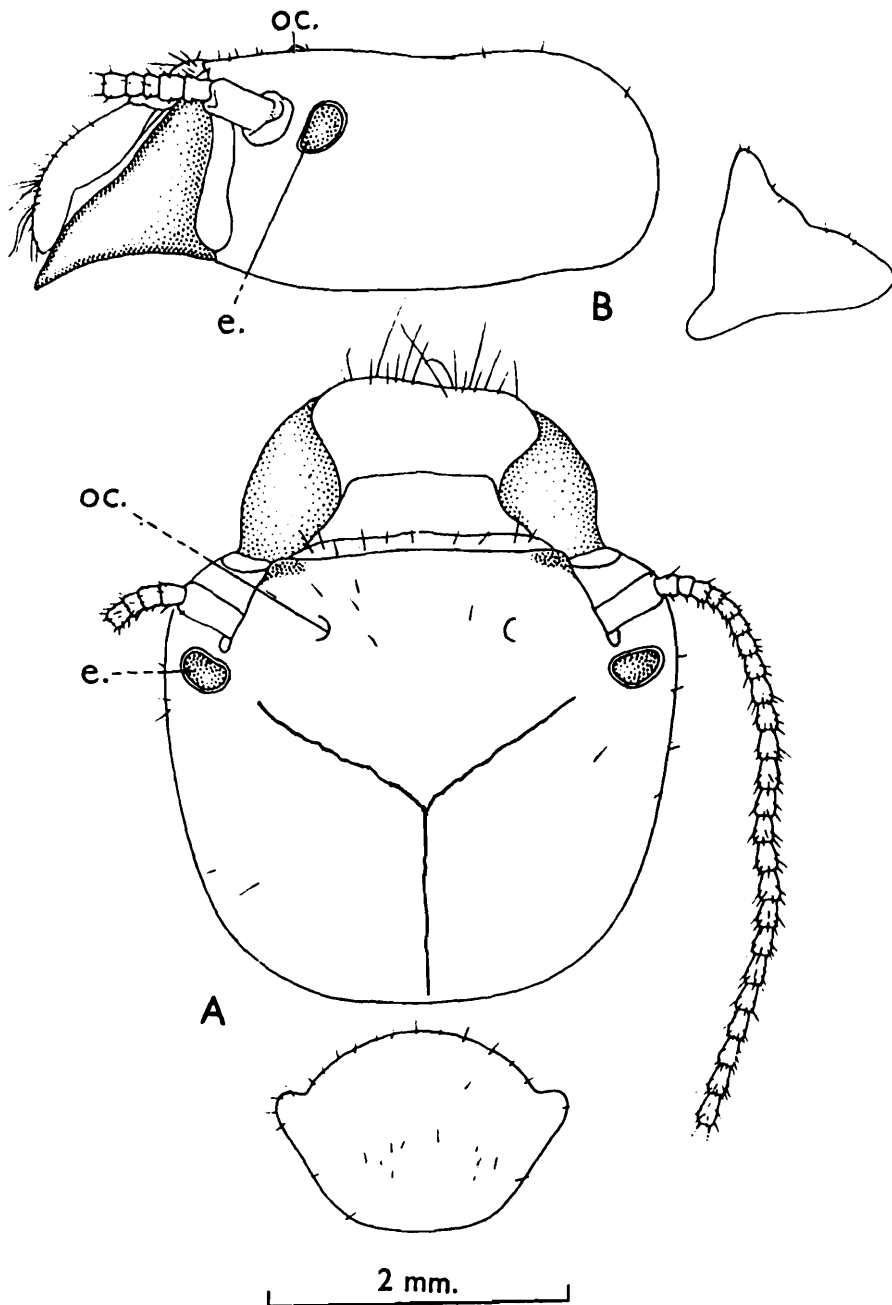

Fig. 93. *Anacanthotermes viarum*. Coimbatore, S. India. Worker. (A) Head and pronotum, in dorsal view. (B) Same, in side view.  
e., eye; oc., ocellus.

mandible base 2.40-4.85, maximum width 2.40-4.65 mm); slightly narrowed anteriorly. Frons rugose, with several transverse ridges in middle. Fontanelle absent. Eyes small, suboval. Ocelli small, almost flush with surface. Antennae with 29-32 segments, segment 3 smallest. Anteclypeus narrow, trapezoidal, apilose. Postclypeus not well differentiated. Labrum broader than long (0.30-0.78 × 0.75-1.38 mm), anterior margin with a shallow, median depression. Mandibles strong, thick, slightly incurved

apically, (length 1.80-3.15 mm); with two strong marginal teeth. Postmentum club-shaped, with a narrow waist. Pronotum narrower than head; broader than long (1.60-3.60 × 0.90-1.95 mm); anterior margin convex, with a weak median notch; posterior margin convex, with a strong notch. Abdomen elongate-oval, sparsely pilose. Cerci and styli short, one-jointed.

**WORKER** (Fig. 93) Colour cream to yellow; sparsely pilose. Total length 8.5-13.3 mm. Head subsquarish, slightly broader than long (maximum width 3.00-3.75 mm). Antennae with 28-33 segments. Left mandible as in imago but small 2nd marginal sometimes absent; right mandible with an apical and two marginal teeth. Pronotum narrower than head and wider than long (length 1.15-1.50, width 1.85-2.18 mm). Legs long, thin; tarsi 4-segmented; apical tibial spur formula 3: 4: 4.

*Distribution* (Fig. 79) : INDIA Peninsular India : Southern and south-eastern portions of Tamil Nadu, in districts of South Arcot, Coimbatore, Madurai, Tirunelveli and Kanniya Kumari. North to c 11.30 N lat., south to the extreme tip of India and west to Coimbatore.

*Biology* : The species lives in underground tunnels and comes out for foraging on grass and other plant material. It builds low mounds, 7-13 cm high, of excavated granular earth. Swarming occurs in late October. Several species of flagellate Protozoa live in the alimentary canal and help in the digestion of wood.

### Family III. KALOTERMITIDAE Froggatt (Synonyms : Protermitidae Holmgren, Calotermitidae auct.)

#### 1. Subfamily Calotermitinae :

1896. Froggatt, *Proc. Linn. Soc. N.S.W.*, 21(2): 516.

1903. Silvestri, *Redia*, 1: 16, 17.

1904. Desneux, *Genera Insectorum*, Fasc. 25: 9, 11.

#### 2. Family Calotermitidae :

1909. Enderlein, *Zool. Anz.*, 35(6): 172.

1949. Grassé, *Traite de Zoologie*, 9: 530.

#### 3. Family Protermitidae :

1909. Holmgren, *K. Sv. Vet. Akad. Handl.*, 44(3): 100 (no description).

1910. Holmgren, *Trans. Linn. Soc. Lond. Zool.*, (2) 14(4): 137.

1911. Holmgren, K. *Sv. Vet. Akad. Handl.*, **46**(6): 10, 13, 14, 33, 34.

4. Family Kalotermitidae :

1919. Banks, *Bull. Mus. Comp. Zool., Harvard College*, **62**(10): 475.

1920. Banks and Snyder, *Bull. U.S. natn. Mus.*, No. 108: 10, 16, 77.

1949. Snyder, *Smiths. misc. Colls.*, **112**: 5, 10, 356.

1960. Roonwal and Sen-Sarma, *Contr. Syst. Orient Termites*, (Ent. Monogr. 1, ICAR 10. 28): 94-99.

1961. Krishna, *Bull. Am. Mus. nat. Hist.*, **122** (Art. 4) : 303-408. (Detailed synonymy, characters, etc.)

1969. Emerson, *Am. Mus. Novit.*, No. 2359: 1-57.

1970. Krishna, In *Biology of Termites* (Eds. Krishna and Weesner) Vol. 2: 129, 130, 132, 134.

1970. Roonwal, In *Biology of Termites* (Eds. Krishna and Weesner) vol. 2: 317, 321, 328.

1972. Chhotani, In *Termite Problems in India* (Ed. Roonwal): 23, 24.

1973. Chhotani and Bose, *Zool. Anz.*, **190**: 232-234.

1975. Chhotani, *Zool. Anz.*, **194** (1 & 2): 111, 124.

1975 Akhtar, *Bull. Dept. Zool. Univ. Punjab*. (N.S), Art. 7: 4, 188, 189, 190.

1977. Roonwal and Chhotani, *Ent. Basiliensia*, **2**: 41.

1977. Roonwal, *Proc. zool. Soc. Calcutta*, **28**(1975): 31, 32-34.

1978. Roonwal and Rathore, *Zool. Anz.*, **200**(3/4): 219, 220-226, 228-231.

1979. Roonwal, *Termite Life and Termite Control in Tropical South Asia* : 8, 9, 10, 76-78.

1980. Chhotani, *Tech. Monogr. Zool. Surv. India*, No. 4: 3, 9.

1983. Roonwal, *Proc. Indian natn. Sci. Acad.*, (B) **49**(5): 362, 366, 367, 377, 378, 382, 383, 385, 387.

1983. Maiti, *Occ. Pap. Rec. zool. Surv. India*, No. 42: 15, 20, 27-44.

1984. Bose, *Occ. Pap. Rec. zool. Surv. India*, No. 49: 13, 14-18.

1986. Grassé, *Termitologia* vol. 3: 495, 506-508.

Type genus : *Kaloterмес* Hagen.

Froggatt (1896) laid the foundation of present day classification of the order Isoptera by dividing the family Termitidae into four subfamilies, including Calotermitinae which was later raised to the family rank by Enderlein (1909). Banks (1919), while describing the family, spelt it

Kalotermitidae instead of Calotermitidae and Banks and Snyder (1920) changed the family name Protermitidae, as used by Holmgren, to Kalotermitidae since the name was not based on any genus included in the family. The genus *Kalotermes* Hagen (1853) for which the family name was introduced has also been spelt as *Calotermes* by different authorities since Hagen (1858) revised the spellings. As the type genus is originally spelt as *Kalotermes*, the family name should also be spelt as Kalotermitidae. Emerson (1942) divided the family Kalotermitidae into two subfamilies *viz.*, Electrotermitinae and Kalotermitinae and this view was accepted by Snyder (1949) and Grassé (1949). Krishna (1961) does not agree with this subdivision and his concept of the family is generally accepted today. Snyder (1949) and Roonwal and Sen-Sarma (1960) assign the authorship of the family to Enderlein (1909), Grassé (1949) to Sjöstedt (1926), Krishna (1961) to Banks (1919) and Emerson (1969) to Froggatt. The assignment of authorship to Froggatt by Emerson (1969) is correct in respect of the Code of Zoological Nomenclature.

### 1. *Characters of Family Kalotermitidae*

*Imago* : Head oval to round; epicranial suture often distinct. Fontanelle absent. Eyes and ocelli present. Antennae with 11-23 segments. Postclypeus flat, not swollen. Labrum subsquarish. Mandibles squarish, left with an apical and two (three in some) marginal teeth; margin between 1st (1st + 2nd of some authors) and 2nd (3rd of some) marginals notched or uniformly incurved; right mandible also with 2 marginals, posterior margin of 2nd marginal subequal to or longer than molar plate. Pronotum flat, as wide as or wider than head with eyes. Forewing scale large, shield-like, overlapping hindwing scale; costa thick, along anterior margin; subcosta short in forewing and fused with costa in hindwing; radius meeting this costa + subcosta; radial sector thick with a number of branches to costa + subcosta; media variable, thick or weak, either running close to radial sector or medially in wing membrane and either meeting the radial sector or running up to distal margin. Wings with a few hairs on margin; membrane hairless or with a few scattered hairs. Wing microsculpturing consisting of finger-like papillae in several rows at the anterior margin; minute, hyaline pimples; and quite often also of large (7-40  $\mu\text{m}$ ) subcrescentic or angular tubercles, generally in rows on veins but sometimes present all over; the last

named may be present or absent in different species of the same genus (*Neotermes*, *Bifiditermes*) (vide Note, infra). Apical tibial spurs 3: 3: 3, extra spines on middle tibiae, in some genera, may be present. Tarsi 4-jointed; arolium present or absent. Cerci 2-jointed.

*Note on wing microsculpturing :*

Wings are covered on both surfaces with fairly dense, microsculpturing which consists of the following 3 kinds of elements but all are not present together in the same species. Papillae and pimpules are present in all and tubercles are either present or absent in different species of same genus (eg. *Neotermes* and *Bifiditermes*). Papillae, small and finger like (length 3-16  $\mu\text{m}$ ), are present in several rows at the anterior margin (density c 3040-8800/ $\text{mm}^2$ ). Pimpules, minute (diameter 2-4  $\mu\text{m}$ ) and hyaline, are present all over membrane (density low to moderate, 510-4300/ $\text{mm}^2$ ). Tubercles are large (basal width 7-40  $\mu\text{m}$ ), either subcrescentic or angular; and are generally present in rows on the veins but sometimes all over (density low to high, 400-6300/ $\text{mm}^2$  (Roonwal 1977a, 1981a, 1983c, 1986 SEM study; Roonwal and Rathore 1978, 1982; Roonwal and Sen-Sarma, 1960; and Roonwal and Verma, 1983).

*Soldier* : Head either large, robust and non truncate or short, truncate and phragmotic; epicranial suture present. Fontanelle absent. Eyes (rudimentary) and ocelli either present or absent. Antennae with 10-20 segments. Mandibles large and strong or short and thick; marginal teeth either large and prominent or short and weak. Postmentum either large, club-shaped or short and oval depending upon shape of head. Pronotum flat. Apical tibial spurs 3: 3: 3; an extra spine on middle tibiae present in genus *Postelectrotermes*. Tarsi 4-jointed.

*Pseudoworker* : Whitish to creamish yellow, grub-like. Head-capsule oval to subcircular. Eyes absent or present. Ocelli absent. Postclypeus flat. Mandibles as in imago. Pronotum flat. Apical tibial spurs 3; 3: 3. Tarsi 4-jointed. Cerci 2-jointed.

## 2. *Distribution and Composition of Kalotermitidae*

*Distribution :*

*Living* : The family is represented in all the zoogeographical regions.

*Fossil* : Africa, Europe, N. America.

A genus-wise distribution is given under genera included in the family, *infra*.

*Composition :*

*Genera included in Kalotermitidae and their distribution*

- |  |  |
|--|--|
| 1. <b>**Proelectrotermes</b> von Rosen | Baltic amber of East Prussia; Upper Eocene         |
| 2. <b>**Electrotermes</b> von Rosen    | Baltic amber of East Prussia; Upper Eocene         |
| 3. <b>*Postelectrotermes</b> Krishna   | Oriental, Ethiopian, Palaeartic and Malagasy.      |
| 4. <b>*Neotermes</b> Holmgren          | Cosmopolitan (except Palaeartic). Eocene, Recent   |
| 5. <b>Rugitermes</b> Holmgren          | Papuan, Neotropical                                |
| 6. <b>Eucryptotermes</b> Holmgren      | Neotropical  |
| 7. <b>**Prokalotermes</b> Emerson      | Florissant bed of Colorado; Oligocene              |
| 8. <b>*Kalotermes</b> Hagen            | Cosmopolitan (except Neotropical)                  |
| 9. <b>Paraneotermes</b> Light          | Nearctic   |
| 10. <b>Ceratokalotermes</b> Krishna    | Australian   |
| 11. <b>Comatermes</b> Krishna          | Neotropical  |
| 12. <b>*Glyptotermes</b> Froggatt      | Cosmopolitan (except Palaeartic and Nearctic)      |
| 13. <b>*Calcaritermes</b> Snyder       | Nearctic, Neotropical, Oriental                    |
| 14. <b>Pterotermes</b> Holmgren        | Nearctic   |
| 15. <b>*Incisitermes</b> Krishna       | Oriental, Papuan, Neotropical and Nearctic         |
| 16. <b>Allotermes</b> Wasmann          | Malagasy   |
| 17. <b>Marginitermes</b> Krishna       | Nearctic   |
| 18. <b>Tauritermes</b> Krishna         | Neotropical  |
| 19. <b>Proneotermes</b> Holmgren       | Neotropical  |
| 20. <b>*Bifiditermes</b> Krishna       | Oriental, Australian, Ethiopian Malagasy           |
| 21. <b>Bicornitermes</b> Krishna       | Ethiopian  |
| 22. <b>*Epicalotermes</b> Silvestri    | Ethiopian, Malagasy, Oriental                      |
| 23. <b>*Procryptotermes</b> Holmgren   | Oriental, Papuan, Ethiopian, Malagasy, Neotropical |
| 24. <b>*Cryptotermes</b> Banks         | Cosmopolitan (except Palaeartic)                   |

---

**\*\*Fossil termites; \*Known from Indian Region.**

3. *Biology of Kalotermitidae*

Species of the family Kalotermitidae are wood infesting termites and have no connection with soil (except in case of *Paraneotermes simplicicornis* Banks (Light, 1937). They are serious pests of forestry and wooden structures in buildings. The nests of these termites are found in dead or live portion of standing trees, fallen logs and wooden structures in buildings. They are in the form of longitudinal, irregular galleries which are filled with dark brownish to brown masses of faecal matter, digested wood and saliva. In case of the species of *Cryptotermes*, infesting wooden structures, poles, etc., the faecal pellets are thrown out and are found lying at base of the infested wood; the galleries are flat, narrow and without any fillings.

Only two true castes viz., the reproductives and the soldiers are found in this family; the worker caste is absent and its functions are performed by the immature reproductives which are called pseudoworkers.

4. *Keys to Indian Region Genera of Kalotermitidae*

IMAGOES

- 1(2). Middle tibia with an outer spine above apical tibial spurs..... **Postelectrotermes**
- 2(1). Middle tibia without any outer spine above apical spurs
- 3(6). Media strongly sclerotised
- 4(5). Radial sector of forewing with branches..... **Neotermes**
- 5(4). Radial sector without branches..... **Glyptotermes & Calcaritermes**
- 6(3). Media weakly sclerotised
- 7(14). Media running up to tip of wing membrane in both wings
- 8(9). Anterior margin of 2nd marginal of left mandible equal to posterior margin of 1st marginal..... **Kalotermes**
- 9(8). Anterior margin of 2nd marginal of left mandible longer than posterior margin of 1st marginal
- 10(11). Media and cubitus in forewing arising independently from scale **Incisitermes**
- 11(10). Media and cubitus in forewing arising jointly from scale and bifurcating in wing membrane.....
- 12(13). Anterior margin of 2nd marginal of left mandible one-and-a-half times that of posterior margin of 1st marginal..... **Epicalotermes**

- 13(12). Anterior margin of 2nd marginal of left mandible less than one-and-a-half times that of posterior margin of 1st marginal..... **Bifiditermes**  
 14(7). Media meeting radial sector in both wings ..... **Procryptotermes & Cryptotermes**

### SOLDIERS

- 1(2). Middle tibia with an outer spine above apical tibial spurs..... **Postelectrotermes**  
 2(1). Middle tibia without any outer spine above apical tibial spurs  
 3(4). Outer apical spur of foretibia greatly thickened and enlarged ..... **Calcaritermes**  
 4(3). Outer apical spur of foretibia not thickened and enlarged  
 5(6). Head truncate in front and phragmotic; mandibles short and stunted..... **Cryptotermes**  
 6(5). Head generally not truncate, long and gradually sloping in front; mandibles generally long  
 7(8). Head with a ridge between frons and vertex..... **Procryptotermes**  
 8(7). Head without any ridge between frons and vertex  
 9(10). Frons bilobed and with a pair of antero-lateral prominences at base; head sometimes phragmotic..... **Glyptotermes**  
 10(9). Frons not bilobed and without any antero-lateral prominence at base; head never phragmotic  
 11(12). Pronotum with anterior margin not deeply incurved or incised.. **Neotermes, Kalotermes**  
 12(11). Pronotum with anterior margin deeply incurved or incised  
 12(13). Femora swollen..... **Incisitermes**  
 13(12). Femora not swollen  
 14(15). Head dorso-ventrally flat, sloping anteriorly from middle; mandibles strongly incurved anteriorly..... **Epicalotermes**  
 15(14). Head thick, sloping anteriorly from in front of middle; mandibles less so incurved anteriorly..... **Bifiditermes**

### Genus 3. Postelectrotermes Krishna

Postelectrotermes Krishna :

1961. Krishna, *Bull. Am. Mus. nat. Hist.*, 122(Art. 4): 315, 316, 319-321, 383, 384, 385. (Synonymy, description, etc.)

1965. Roonwal and Maiti, *Indian J. Ent.*, 27(3): 255, 261.
1965. Bouillon and Mathot, *Zooleo*, No. 1 : 12, 16, 76, 77.
1966. Bouillon and Mathot, *Zooleo*, No. 1 (Suppl. 1): Table of measurement, between pp. 4 and 5.
1970. Krishna, In *Biology of Termites* vol. 2 (Eds. Krishna and Weesner): 133. New York (Academic Pr.).
1971. Roonwal and Verma, *Indian Zoologist*, 2: 87-89.
1971. Bouillon and Mathot, *Zooleo*, No. 1 (Suppl. 2): Table between pp. 4 and 5 (Measurements).
1972. Chaudhry and Ahmad, *Termites of Pakistan (Final Tech. Rep. PL 480 Proj.)* : 1.
1973. Chhotani and Bose, *Zool. Anz.*, 190(3/4): 232, 234.
1974. Akhtar, *Pakistan J. Zool.*, 6(1 & 2): 88, 89, 96, 97, 100.
1975. Chhotani, *Zool. Anz.*, 194(1/2): 111-112, 115, 116, 117, 120, 121.
1977. Roonwal, *Proc. zool. Soc., Calcutta*, 28(1975): 31, 32, 33.
1979. Roonwal, *Termite Life and Termite Control in Tropical South Asia*: 4, 13. Jodhpur (Sci. Publ.).
1980. Chhotani, *Tech. Monogr. Zool. Surv. India*, No. 4: 3, 9-10.
1983. Roonwal, *Proc. Indian natn. Sci. Acad.*, (B) 49(5):362.
1984. Bose, *Occ. Pap. Rec. zool. Surv. India.*, No. 49: 14, 15, 17, 18.
1986. Grasse, *Termitologia*, vol 3: 510, 516-517.

Type of genus : *Calotermes praecox* Hagen

### 1. Characters of Genus *Postelectrotermes*

**Imago** : Yellowish brown to dark brown in colour. Head subcircular; epicranial suture present. Eyes usually small, 0.25-0.50 mm in diameter. Ocelli small, oval, either touching or very close to eyes. Antennae with 13 to 20 segments. Postclypeus flat. Mandibles each with an apical and two marginal teeth; left with posterior margin of 1st (1st + 2nd of some authors) equal to anterior margin of 2nd (3rd of some), sometimes with a tooth-like projection; right with posterior margin of 2nd marginal equal to molar plate in length. Pronotum flat, wider than head. Forewing with all major veins arising independently from scale; costa thick; subcosta thick and short, meeting costa near scale; radius thick, meeting costa before middle of wing, sometimes branched; radial sector also thick running close to and parallel

with costa, with 7-12 branches to costa; media slightly less sclerotised than radial sector, running closer to it than to cubitus and with many cross veins to radial sector; cubitus weak with a number of (generally 9-11) branches to posterior margin, the branches subdividing sometimes to form reticulation. Hindwing venation as in forewing except subcosta absent and media arising from radial sector in wing membrane. Membrane of both wings tuberculate; tubercles 18-30  $\mu\text{m}$  long, density per sq. mm at middle of membrane 9 in forewing and 20 in hindwing (*P. militaris*, not studied in other species). Apical tibial spurs 3: 3: 3; middle tibia with a thick, dark spine on outer side a little above spurs; arolium present.

*Soldier* : Head generally brown, darker brown anteriorly; abdomen yellowish. Head-capsule subrectangular or elongately oval, longer than wide; frons inclined in front at 25-45° degrees and medially depressed in some species to form weak lateral prominences; Y-suture either present or absent. Eyes generally present and unpigmented (absent in *nayari* and pigmented in *pishinensis*). Antennae with 11-18 segments; segment 3 subequal to or a little larger than 2. Labrum broad, tongue-like or dome-shaped. Mandibles long and stout, about half to three fourths of head-length to base of mandibles, weakly incurved distally; left with 2-5 marginals. Postmentum long, club-shaped; waist about one-third of maximum width; anterior broader portion sometimes bilobed. Pronotum narrower to broader than head; anterior margin weakly concave or angularly incurved. Legs long and stout; apical tibial spurs 3: 3: 3; middle tibia with a thick, dark spine on outer margin a little above spurs.

*Pseudoworker* : Creamy whitish, grub-like. Head-capsule subcircular; Y-suture absent. Eyes rudimentary. Antennae with 14-17 segments. Mandibles as in imago, sometimes a small marginal between 1st and 2nd marginals of left mandible present. Pronotum as wide as or a little wider than head; anterior margin weakly to appreciably strongly incurved, with or without a median notch. Legs as in soldier.

## 2. *Distribution and Composition of Postelectrotermes* (Fig. 94)

The genus is known from Oriental (6 spp.), Ethiopian (one species), Malagasy (5 spp.) and Palaearctic (2 spp.) zoogeographical regions.

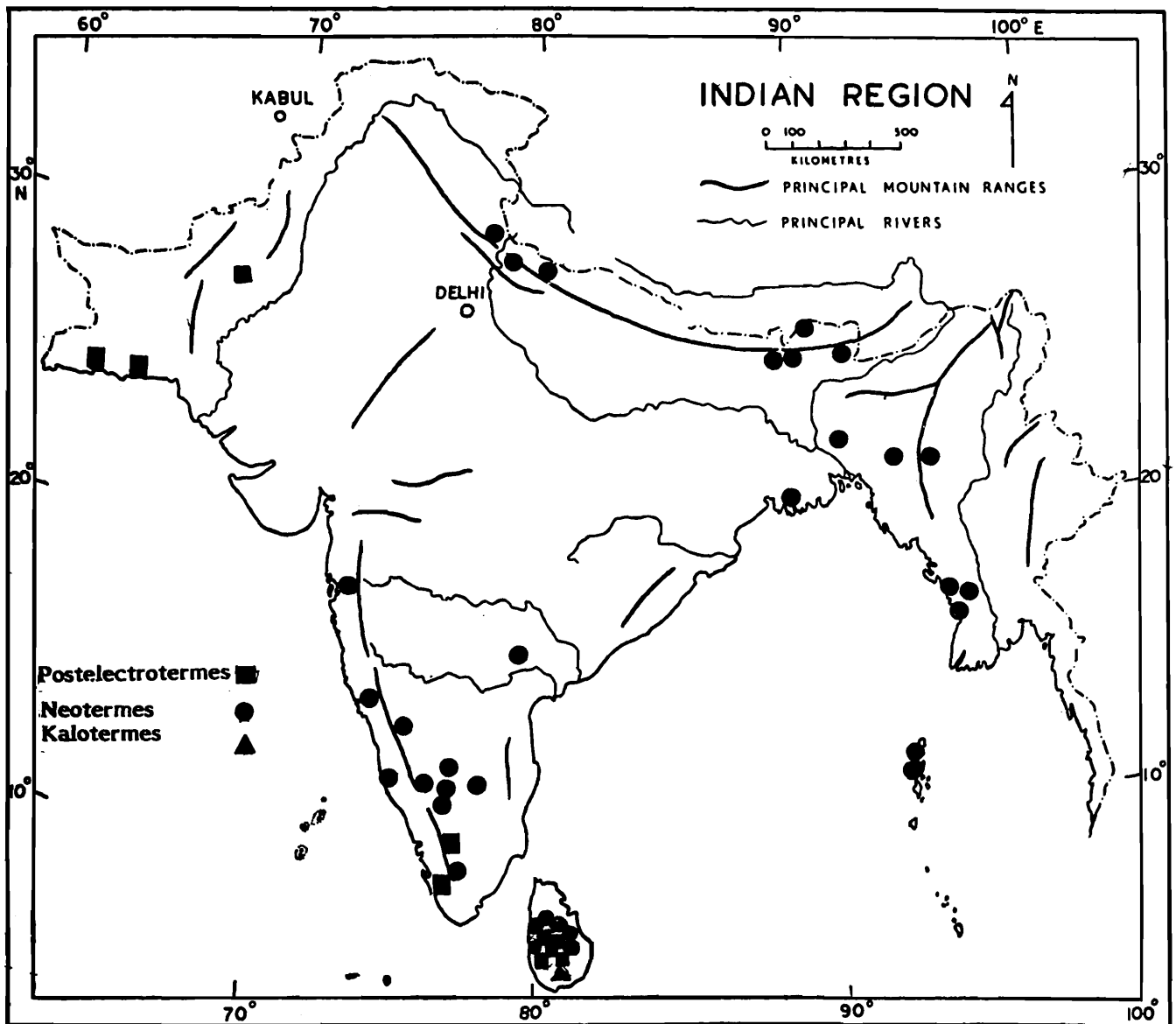

Fig. 94. Map of the Indian Region, showing distribution of genera *Postelectrotermes*, *Neoterme* and *Kaloterme* (Kalotermitidae).

*List of species from Indian Region :*

1. *Postelectrotermes bhimi* Roonwal and Maiti. India : Kerala.
2. *P. militaris* (Desneux). Sri Lanka.
3. *P. nayari* Roonwal and Verma. India : Kerala.
4. *P. pasniensis* Akhtar. Pakistan : Baluchistan.
5. *P. pishinensis* Ahmad. Pakistan. Baluchistan.

3. Keys to Indian Region Species of *Postelectrotermes*

## IMAGOES

Of the five species of the genus, imagoes are known for only three.

- 1(2). Larger species. Head-width with eyes 1.90-1.95 mm; antennae 19-20 segmented; eyes larger, maximum diameter 0.45-0.50 mm..... *militaris*
- 2(1). Smaller species. Head-width with eyes 1.0-1.5 mm; antennae 15-18 segmented; eyes smaller, maximum diameter 0.23-0.38 mm
- 3(4). Pronotum larger (maximum length 0.70-0.76, maximum width 1.29-1.47 mm); wider than head with eyes..... *pasniensis*
- 4(3). Pronotum smaller, (max. length 0.54-0.68, max. width 0.98-1.20 mm); narrower than head with eyes..... *nayari*

## SOLDIERS

- 1(2). Eyes absent ..... *nayari*
- 2(1). Eyes present
- 3(6). Eyes larger, long diameter 0.15-0.24 mm
- 4(5). Larger species. Head-length to base of mandibles 2.88-3.31, head-width 1.98-2.34 mm. Mandibles longer, about half to little more than half of head-length (index Left mandible length/Head-length 0.51-0.64); left mandible with 4 marginal teeth..... *militaris*
- 5(4). Smaller species. Head-length to base of mandibles 2.6, head-width 1.5 mm; mandibles shorter, less than half of head-length (index 0.43); left mandible with 5 marginal teeth..... *bhimi*
- 6(3). Eyes smaller, long diameter less than 0.15 mm
- 7(8). Head elongately oval, generally smaller, head-length to base of mandibles 2.11-2.25, head-width 1.41-1.62 mm; mandibles about three-fourths of head-length; antenna 16-segmented..... *pishinensis*
- 8(7) Head rectangular, generally larger, head-length to base of mandibles 1.80-3.19, head-width 1.28-1.71 mm; mandibles about half of head-length; antennae 13 to 15 segmented ..... *pasniensis*

6. *Postelectrotermes bhimi* Roonwal and Maiti  
(Figs. 95, 96)

*Postelectrotermes bhimi* Roonwal and Maiti :

1965. Roonwal and Maiti, *Indian J. Ent.*, 27(3): 255-261. 5, Pw. Hologype : S in ZSI.

Type-locality : Vandiperiyar, Kottayam Dist., Kerala, India.

1975. Chhotani, *Zool. Anz.*, 194 (1 & 2) : 112, 115, 117.

1979. Roonwal, *Termite Life and Termite Control* : 116. Jodhpur (Sci. Publ.).

1980. Chhotani, *Tech. Mongr. Zool. Surv. India*, No. 4: 3, 9, 10, 67.

1984. Bose, *Occ. Pap. Rec. Zool. Surv. India*, No. 49: 18-20.

IMAGO : Unknown.

**SOLDIER (Fig. 95)** : Head-capsule brownish, anteriorly deep brownish to black, posteriorly pale yellowish; antennal segments basally pale distally darker; labrum dark brown; mandibles black; pronotum yellowish brown, margins darker; meso- and metanotum paler; abdomen yellowish. Head and body sparsely hairy. Total length including mandibles c 7.8 mm. Head-capsule much longer than broad, rectangular; length of head to base of mandibles 2.60; maximum head-width 1.50 mm, index Width/Length 0.57;

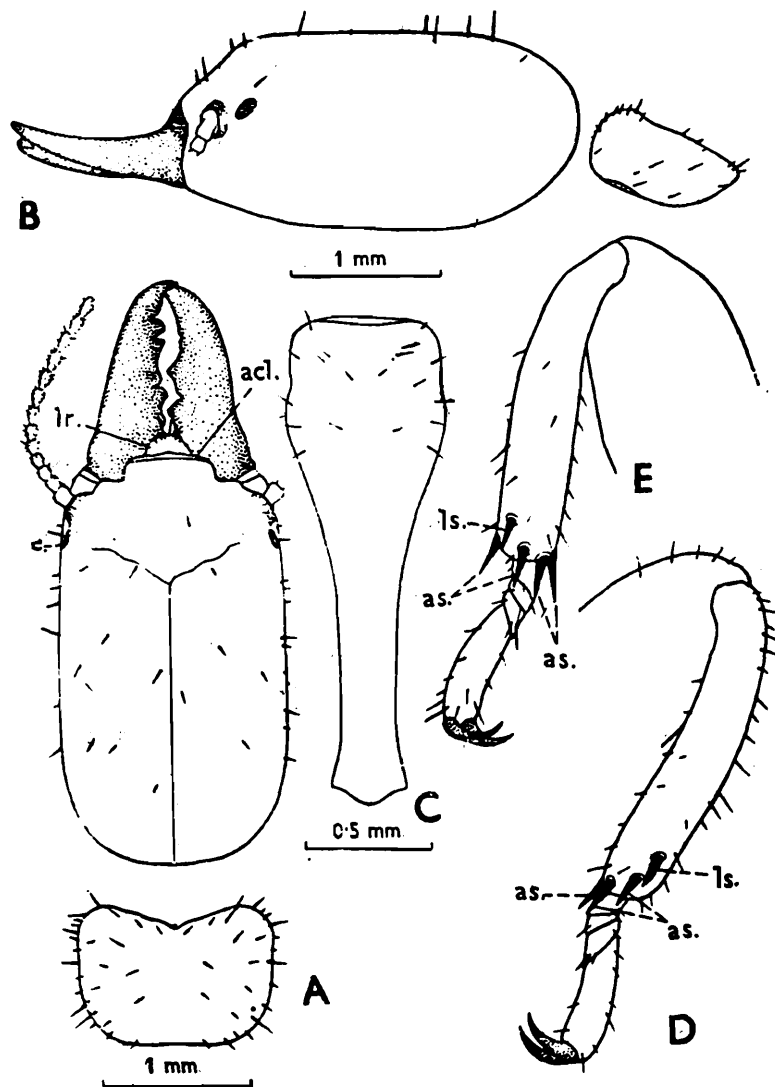

**Fig. 95.** *Postelectrotermes bhimi*. Soldier. (A) Head and pronotum, in dorsal view. (B) Same, in side view. (C) Postmentum. (D) and (E) Lower part of middleleg, showing apical tibial spurs and lateral spine; left and right legs, respectively. acl., anteclypeus; as., apical spur; ls., lateral spine. (After Roonwal and Maiti, 1965).

sides subparallel, slightly narrowing anteriorly; posterior margin rounded; frons weakly sloping anteriorly; Y-suture present, not prominent. Eyes whitish, small, elongately oval, 0.15 mm long. Ocelli absent. Antennae 13 + segmented; segments 2 and 3 subequal, 4th shortest. Anteclypeus present as a narrow whitish strip at base of labrum; postclypeus flat, not clearly differentiated from frons. Labrum tongue-shaped, much broader than long, with 3-4 bristles on either side of anterior margin. Mandibles long, stout; apically weakly incurved; a little less than half of length of head to mandible-base; index  $\text{Left mandible-length/Head-length to base of mandibles}$  0.43; left mandible with five marginal teeth; right with two marginal teeth. Postmentum flat, club-shaped, long, wider anterior portion weakly bilobed; narrowing posteriorly to a long, narrow waist; length 1.93; maximum width 0.60, minimum width 0.23 mm. Pronotum subrectangular, much broader than long; with a few short hairs on margins and on body; width 1.37, length 0.93 mm; a little narrower than head, index  $\text{Pronotum-width/Head-width}$  0.91; anterior margin deeply incurved, medially notched; posterior margin with a weak, median notch. Legs short, sparsely hairy; femora swollen, tibiae slender; apical tibial spurs 3: 3: 3; a stout, lateral spine present a little above spurs on outer margin of middle tibia; tarsi 4-jointed. Abdomen long, oval, moderately pilose; cerci short, 2 jointed, hairy 0.09 mm long; styli with 2-3 hairs near tip, single-jointed.

**PSEUDOWORKER** (Fig. 96) : Head capsule creamy white; pronotum paler; clypeus and labrum yellowish brown; mandibles pale brown with black teeth; antennae, legs and abdomen yellowish white. Head sparsely and rest of body moderately pilose. Total length 4.6-7.0 mm. Head subcircular, slightly broader than long; head-width 1.30-1.36, head-length to base of mandibles 1.23-1.33 mm. Eyes rudimentary, present as small circular, whitish patches below antennae. Ocelli absent. Antennae 14-15 segmented, 4th segment shortest. Labrum broader than long, width 0.47-0.52, length 0.28-0.35 mm; anterior margin rounded. Anteclypeus narrow; postclypeus broader than long. Left mandible with an apical and 2 marginal teeth, posterior margin of 1st sometimes with a tooth-like projection. Right mandible with an apical and 2 marginal teeth. Pronotum flat; width 1.23-1.33, length 0.74-0.80 mm; anterior margin weakly concave with a median notch; posterior margin substraight, weakly notched medially. Legs and abdomen as in soldier.

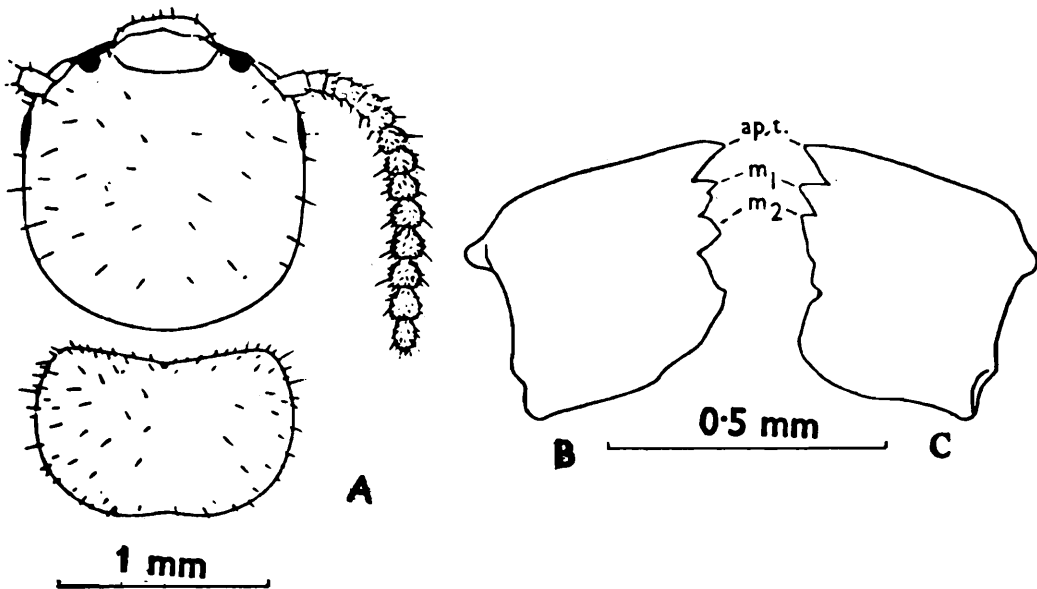

Fig. 96. *Postelectrotermes bhimi*. Pseudoworker. (A) Head and pronotum, in dorsal view. (B) and (C) Left and right mandibles, respectively.  
ap. t., apical tooth; m<sub>1</sub>, m<sub>2</sub>, 1st and 2nd marginal teeth.

*Distribution* : INDIA : Vandiperiyar Village, Kottayam District, Kerala state.

*Host* : Tea plant.

**7. *Postelectrotermes militaris* (Desneux)**  
(syn. *Calotermes militaris* ab. *unidentatus* Kemner)  
(Figs. 97-99)

1. *Calotermes militaris* Desneux :

1904. Desneux, *Ann. Soc. Ent. Belg.*, 48(3): 146, Soldier. Holotype : Repository not known. Type-locality : Sri Lanka.

2. *Neotermes militaris* (Desneux) :

1958. Ahmad, *Biologia* (Lahore), 4: 39, 43. Keys.

1960. Roonwal and Sen-Sarma, *Contrib. Syst. Orient. Termites* (ICAR Ent. Monogr. No. 1): 226-233, pl. 56, 57. See for detailed synonymy.

1962. Fernando, In *Termites Humid Tropics* (Proc. New Delhi Symp., 1960) : 205, 206, 207, 208.

3. *Postelectrotermes militaris* (Desneux) :

1961. Krishna, *Bull. Am. Mus. nat. Hist.*, 122 (Art. 4): 321.

1965. Roonwal and Maiti, *Indian J. Ent.*, 27(3): 255, 261.

1971. Roonwal and Verma, *Indian Zoologist*, 2: 88, 89.

1971. Roonwal and Verma, *Indian Zoologist*, 2: 87, 88, 89.

1974. Akhtar, *Biologia* (Lahore), 20(1): 26, 29.

1975. Chhotani, *Zool. Anz.*, 194(1 & 2): 112, 115, 117.

1977. Roonwal, *Proc. zool. Soc., Calcutta*, 29(1975): 32, 33.

1979. Roonwal, *Termite Life and Termite Control in Tropical South Asia* : 116. Jodhpur (Sci. Publ.)

1980. Chhotani, *Tech. Monog. Zool. Surv. India*, No. 4: 3, 10, 11, 12, 67.

1984. Bose, *Occ. Pap. Rec. zool. Surv. India*, No. 49: 15.

4. *Calotermes militaris* ab. *unidentatus* Kemner :

1926. Kemner, *Bull. ent. Res.*, 16(4): 381-382. S, neoteinic and Ny. Holotype repository not known. Type-locality: Bogowantalawa, Sri Lanka.

Also see Roonwal and Sen-Sarma 1960 for synonymy.

**IMAGO** (Fig. 97, 98) : Head, pronotum and body reddish brown; antennae, legs, abdominal sternites, wing-scales and anterior veins of wings pale brown; wings yellowish. Head and body sparsely pilose. Total length without wings c 10.0-12.0, with wings 19.0-20.5 mm. Head-capsule suboval, maximum width with eyes subequal to length to base of mandibles; width 1.90-1.95, length 1.40-1.70 mm; Y-suture absent or indistinctly marked. Eyes large, black, circular; maximum diameter with ocular sclerite 0.45-0.50 mm. Ocelli oval, translucent, almost touching the ocular sclerite.

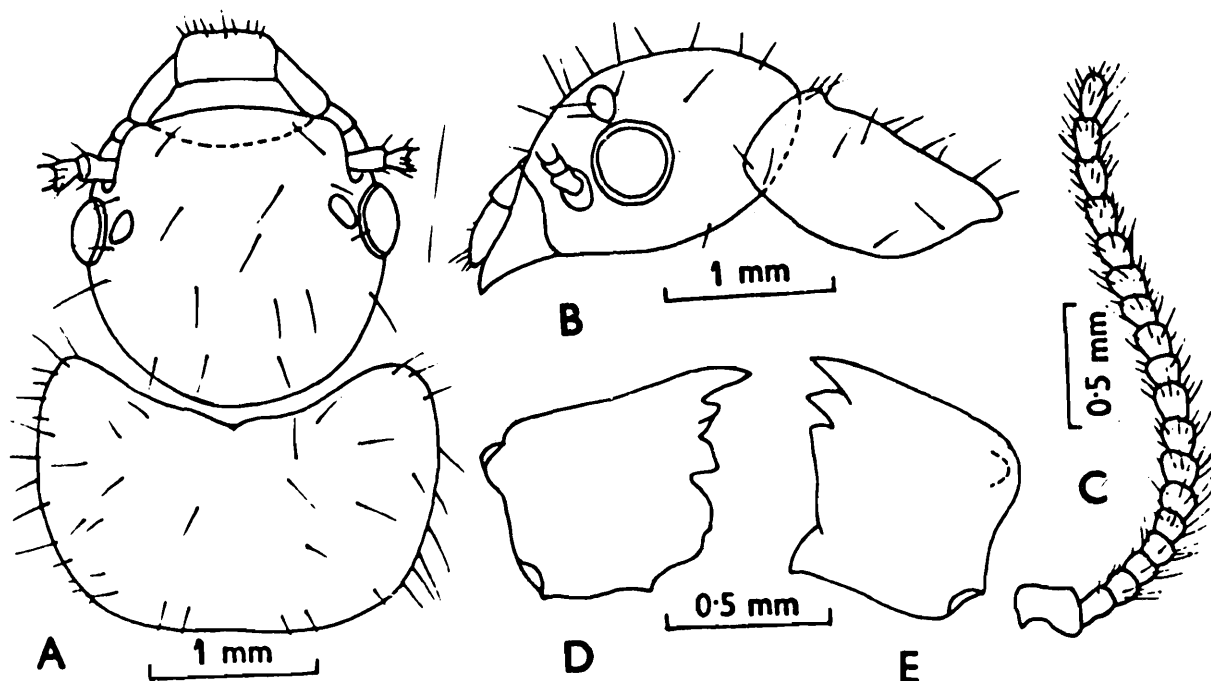

Fig. 97. *Postelectrotermes militaris*. Imago. (A) Head and pronotum, in dorsal view. (B) Same, in side view. (C) Antenna. (D) and (E) Left and right mandibles, respectively. (Redrawn from Roonwal and Sen-Sarma 1960).

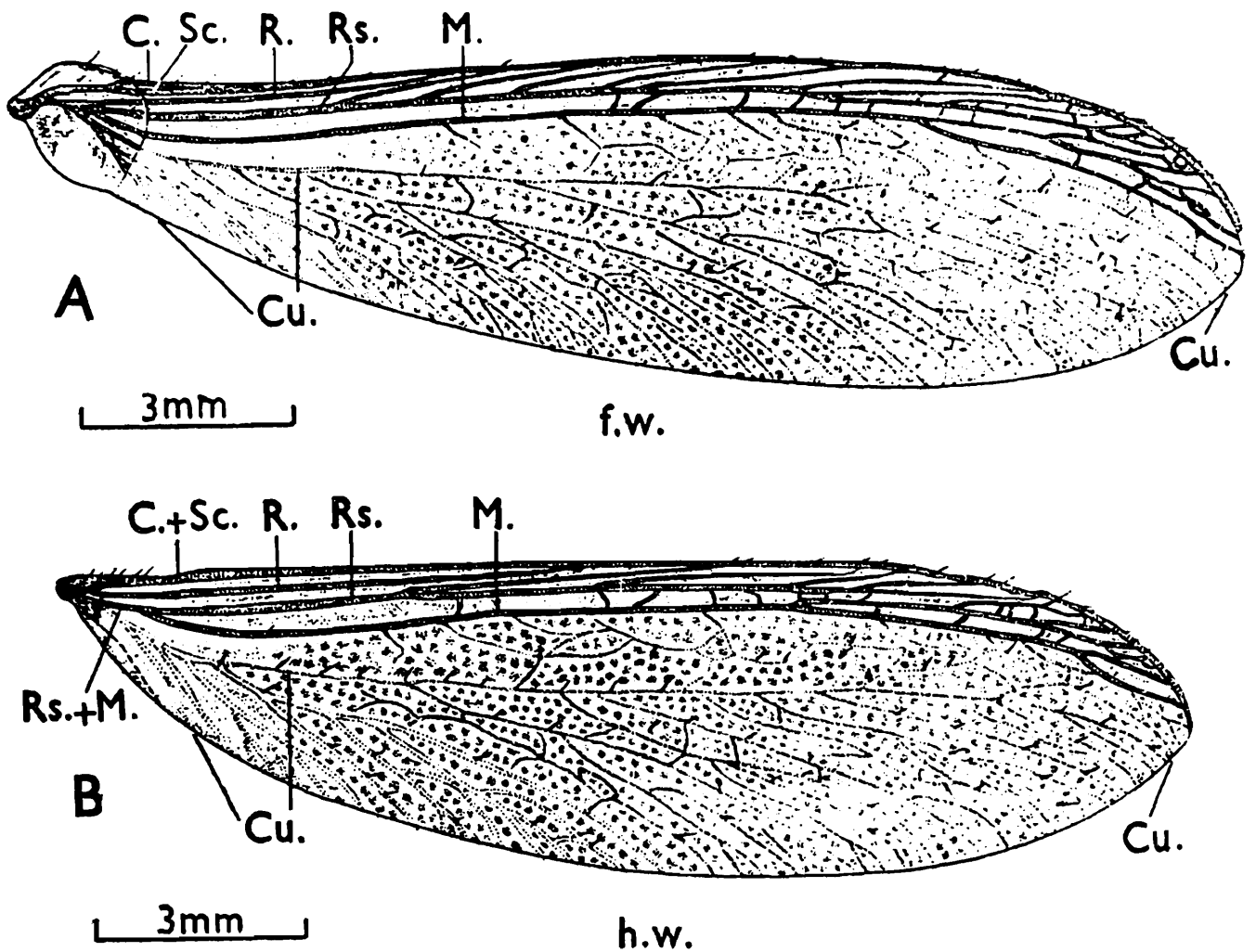

Fig. 98. *Postelectrotermes militaris*. Wings. (A) Right forewing. (B) Right hindwing.

C., costa; Cu., cubitus; f.w., forewing; h.w., hindwing. M., media; R., radius; Rs., radial sector; Sc., subcosta. (After Roonwal and Sen-Sarma 1960).

Antennae densely pilose; 19-20 segmented; segments 2 and 3 subequal, 4 shorter than 3. Anteclypeus trapezoidal, whitish; postclypeus darker than rest of head, anteriorly weakly and posteriorly strongly, convex. Labrum squarish, subparallel sided; length 0.45, width 0.50-0.55 mm; with a few hairs at tip. Mandibles of typically *Postelectrotermes*-type. Pronotum subrectangular, much broader than head-width with eyes; length 1.3-1.4, width 2.10-2.20 mm; anterior margin broadly incurved, posterior margin substraight, shallowly incurved medially. Legs long, slender, pilose; apical tibial spurs 3: 3: 3; middle tibia with an outer, thick spine a little above spurs; empodium between claws present. Wings hairy, tuberculate; length with scale, forewings 17.2-17.6, hindwings 15.5-15.6 mm; Forewing scale larger

than in hindwing; venation as in genus; microsculpturing consisting of tubercles on membrane, density per sq mm 9 in forewing and 20 in hindwing in middle of wing-membrane. Abdomen elongate, hairy; cerci short, 2-segmented, hairy.

**SOLDIER** (Fig. 99): Head-capsule brown to pale castaneous brown, frons darker; antennae basally brown, apically paler; labrum pale brown; pronotum, legs and body yellowish white. Head and body sparsely pilose. Total length c 10.5-11.0 mm. Head-capsule subrectangular with parallel sides; length to base of mandibles 2.88-3.31, width 1.80-2.34 mm; posteriorly rounded; frons sloping anteriorly and with a shallow depression extending up to occiput; Y-suture not visible. Eyes suboval, translucent, elongate; maximum diameter 0.24 mm; separated from antennae by slightly less than maximum diameter. Ocelli absent. Antennae 16-18 segmented, fairly densely pilose, segments 2 and 3 subequal, 4 shortest. Anteclypeus trapezoidal, whitish, apilose. Postclypeus subrectangular, darker than frons; with two pairs of hairs on anterior margin. Labrum subsquarish; length

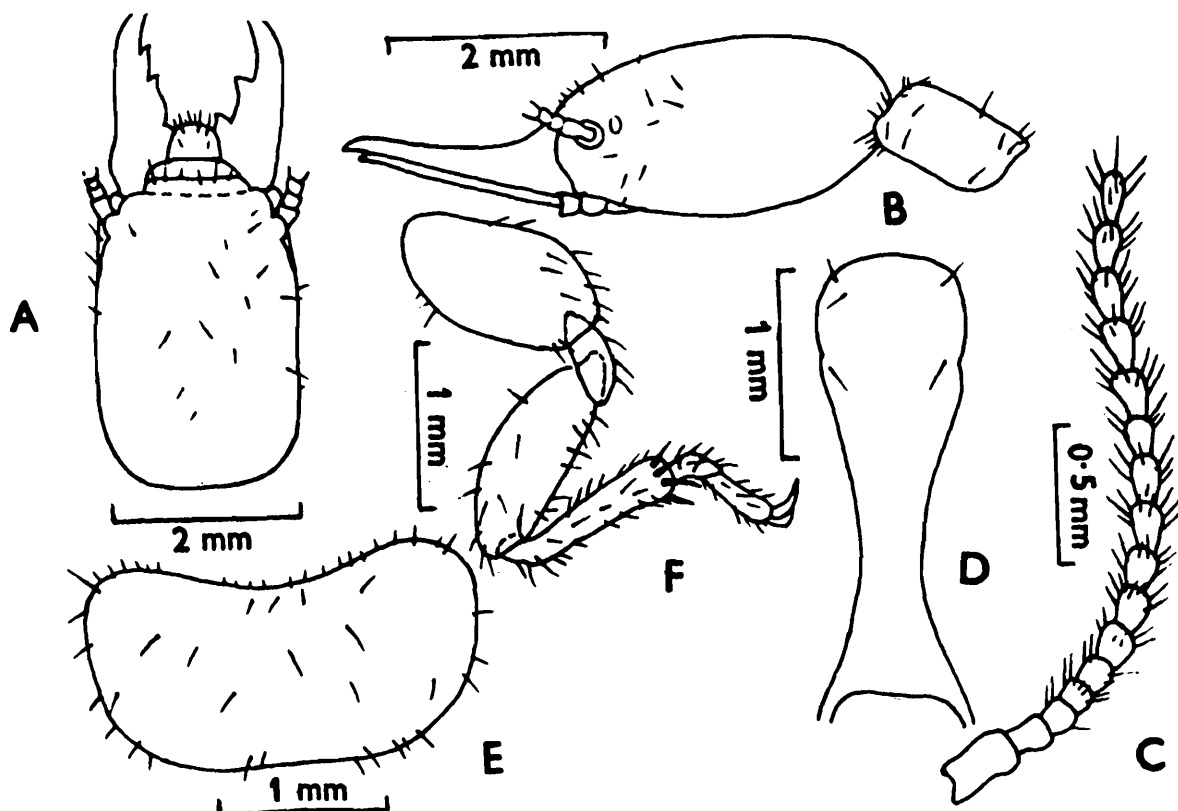

Fig. 99. *Postelectrotermes militaris*. Soldier. (A) Head, in dorsal view. (B) Head and pronotum, in side view. (C) Antenna. (D) Postmentum. (E) Pronotum, in dorsal view. (F) Middle-leg showing tibial spurs and lateral spine. (Redrawn from Roonwal and Sen-Sarma 1960).

0.30-0.54, width 0.54-0.60 mm; with a weakly pointed medial tip on anterior margin and a few hairs on body. Mandibles long, slender; fairly straight with weakly incurved apices, not swollen basally; length subequal to or more than half of head-length to base of mandibles; length of left mandible 1.62-1.89 mm; index Left mandible-length/Head-length to base of mandibles 0.51-0.64. Left mandible with 4 marginal teeth; right with 2 marginal teeth. Postmentum long, club-shaped, broadest in anterior half, narrowing in middle and widening out slightly at base; anterior broader part bilobed; anterior margin rounded, posterior margin substraight. Pronotum subrectangular; maximum length 0.95-1.20, maximum width 1.98-2.46 mm; about as broad as head; anterior margin shallowly concave, posterior margin substraight. Legs long, slender, sparsely pilose; femora not swollen, apical tibial spurs 3: 3: 3; middle tibia with an outer thick spine above spurs; tarsi 4-segmented. Abdomen elongately oval; each tergum with two rows of hairs; cerci 2-segmented, hairy.

**PSEUDOWORKER** : Head-capsule and labrum straw coloured; mandibles also straw coloured, toothed margins brown; antennae, pronotum, legs and body yellowish white. Head and body fairly pilose. Total length c 7.0-8.0 mm. Head-capsule subrounded, length to base of mandibles 1.6-1.7, width 1.6-1.8 mm; moderately pilose; frons weakly sloping anteriorly and with a medial depression. Eyes rudimentary, present as small, white, circular, faint impressions; flush with head-surface. Ocelli absent. Antennae 15-17 segmented, pilose; segments 3-5 shortest. Anteclypeus trapezoidal, white; postclypeus rectangular, flat, darker than frons; with 2 pairs of hairs on anterior margin. Labrum subsquarish, broadest near middle; with hairs on tip and on body. Mandibles as in imago. Pronotum broader than head; width 1.8-2.2; length 0.9-1.3 mm; anterior margin deeply concave, not medially notched, posterior margin straight. Legs and abdomen as in soldier.

**Distribution** : Widely distributed in Sri Lanka, for details vide Roonwal and Sen-Sarma, 1960.

**Hosts** : Tea bushes and a number of other plants, for details vide Chhotani, 1980.

**Biology** : Occurs at elevations of about 1,000-1,300 m in Sri Lanka. It is a serious pest of tea bushes and infests roots and stem. The nest is made up

of irregular cavities and tunnels in the heartwood. The colonies are generally small but sometimes a tea bush may have 3,000-4,000 individuals (Pinto, 1941).

### 8. *Postelectrotermes nayari* Roonwal and Verma (Fig. 100)

*Postelectrotermes nayari* Roonwal and Verma :

1971. Roonwal and Verma, *Indian Zoologist*, 2: 83-91. S, Pw. Holotype: S, in ZSI, Calcutta. Type-locality: Trivandrum (Chackai), Kerala State, India. Type examined.
1975. Chhotani, *Zool. Anz.*, 194 (1 & 2): 112, 115, 117.
1976. Varma, *Bull. ethol. Soc. India*, 1(3): 64-67. Nests and nesting behaviour.
1977. Varma *Indian Forester*, 103(3): 219-224. Im.
1977. Varma, *Indian J. Exptl. Biol.*, 15(7): 564-565.
1979. Roonwal, *Termite Life and Termite Control in Tropical South Asia*: 116. Jodhpur (Sci. Publ.).
1980. Chhotani, *Tech. Monogr. Zool. Surv. India*. No. 4: 9.
1984. Bose, *Occ. Pap. Rec. zool. Surv. India*, No. 49: 18, 19, 20-21.

**IMAGO** : Head-capsule yellowish brown, anteriorly paler; pronotum yellowish brown; antennae, labrum and legs pale yellow; wings brownish, yellowish white in younger forms. Head and body moderately pilose; wings with a few hairs on anterior margin of forewings. Total length with wings 10.0-12.0, without wings 6.5-8.0 mm. Head capsule subcircular; length to base of mandibles 1.85-2.10, width with eyes 1.00-1.5 mm\*; Y-suture present. Eyes fairly large, oval; max. diameter 0.25-0.33 mm. ocelli small, oval; length 0.12 mm; nearly touching eyes. Antennae 15-18 segmented; segment 4 shortest, segments 1, 2 and 3 apilose, rest moderately pilose. Anteclypeus slightly swollen; postclypeus flat, slightly darker than anteclypeus. Mandibles as in genus. Labrum subsquarish; length 0.38-0.45, width 0.50-0.58 mm; anterior margin rounded. Pronotum flat, much broader than long; width 0.98-1.20, length 0.54-0.68 mm; sides subrounded;

---

\* Measurements of head taken from Varma 1977b seem to be incorrect as they do not conform with the figure given by him. The imago specimens of the species were also not available to enable us to check. They are probably lost as informed by Varma (personal communication).

anterior margin substraight. Forewings a little longer than hind wings; wing venation as in genus. Femora swollen; apical tibial spurs 3: 3: 3; a prominent, outer spine present on middle tibia; Tarsi 4-jointed; arolium present. Abdomen, elongate, pilose; cerci 2-jointed.

**SOLDIER (Fig. 100)** : Head dark brown, mandibles dark brown, distally black; anteclypeus whitish; antennae pale brown. Head moderately, and body fairly, densely pilose. Total length with mandibles c 10.0-12.0 mm. Head-capsule subrectangular, subparallel sided and posteriorly rounded; length to lateral base of mandibles 3.16-3.68 mm, maximum width 2.10-2.89 mm; frons sloping distally; Y-suture not visible. Eyes and ocelli absent. Antennae : 12-15 segmented, hairy; antennal carinae well marked; segments 2 and 3 short, subequal; 4 slightly longer than 2 or 3. Anteclypeus, whitish, narrow, trapezoidal, apilose. Postclypeus brownish, narrow, subrectangular, fairly pilose. Labrum large, broad, distally rounded; length 0.39-0.42, width 0.53-0.58 mm. Mandibles stout, long, about 2/3 to 3/4 of head-length, to length 2.37-2.53 mm, index left Mandible - length/ Head-length base of mandibles 0.65-0.75; outer margins substraight, apically incurved. Left mandible with 2-5 marginal teeth; right with 2 marginal teeth.

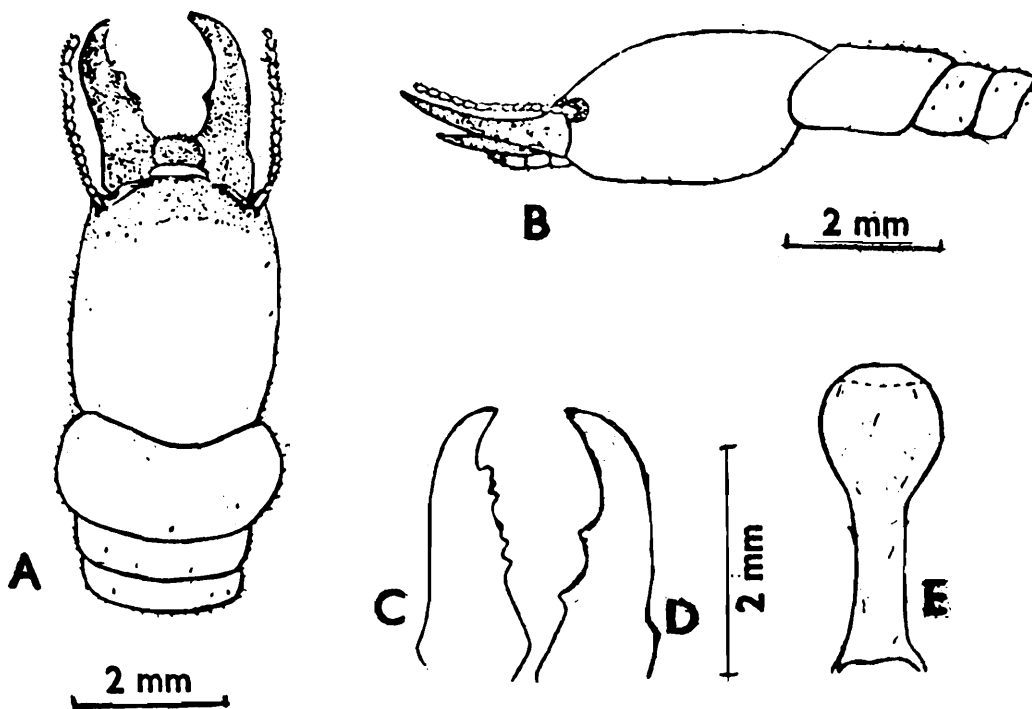

Fig. 100. *Postelectrotermes nayari*. Soldier. (A) Head and thorax, in dorsal view. (B) Same, in side view. (C) and (D) Left and right mandibles, respectively. (E) Postmentum. (Redrawn from Roonwal and Verma 1971).

Postmentum long, club shaped, broadest anteriorly, narrowest in middle, and widening slightly at base; median length 2.37-2.84, maximum width 0.95-1.05, minimum width 0.32-0.42 mm. Pronotum subrectangular with substraight sides, much broader than long; width 2.42-3.16, length 1.26-1.58 mm; broader than head, index Pronotum-width/Head-width 1.19-1.38; anterior margin concave, posterior margin substraight. Meso- and metanota, narrower than pronotum. Legs short; femora and tibia swollen; apical tibial spur formula 3: 3: 3; middle tibia with a large spine above spurs; tarsi 4-segmented. Abdomen oval, elongate; each tergum with two rows of hairs; cerci 2-jointed, short, 0.18 mm long, pilose; styli one-jointed, short.

**PSEUDOWORKER** Head and body dirty pale straw-coloured, moderately hairy; mandibles darker, blackish at toothed edges. Total length c 6.7-7.5 mm. Head-capsule rounded, broader than long; length to base of mandibles 1.58-1.74, max. width 2.05-2.21 mm; moderately pilose with short, stiff hairs. Eyes and ocelli absent. Labrum subsquarish, distal edge rounded. Anteclypeus slightly swollen. Postclypeus flat, darker than frons. Antennae 16-segmented, fairly pilose; segments 2 and 3 shortest, subequal. Pronotum subrectangular slightly broader than head and broader than long; width 2.10-2.37, length 1.05-1.32 mm; anterior margin concave, without median notch; posterior margin almost straight and with a weak median notch.

*Distribution* : India : Trivandrum (Chackai), and Ponmudi and Kula-thupuzha forest areas (Trivandrum District), Kerala State.

*Hosts* : Dead wood of *Pterocarpus marsupium* and of unknown trees.

*Biology* : This termite generally attacks dead and decaying wood. Its nest consists of simple tunnels or galleries which are devoid of any faecal pellets. Faecal matter may be found in plenty in abandoned chambers (Varma, 1976).

### 9. *Postelectrotermes pasniensis* Akhtar (Figs. 101, 102)

1. *Postelectrotermes pasniensis* Choudhury and Ahmed :

1972. Chaudhury and Ahmad, *Termites of Pakistan* (Final Tech. Rept., Pl. 480 Program) : 1. Nom. nud.

2. *Postelectrotermes pasniensis* Akhtar :

1974. Akhtar, *Biologia* (Lahore), 20(1): 24-29. Imago, Soldier. Holotype: S, in Zool. Dept., Panjab Univ., Lahore. Type-locality : Pasni, Baluchistan, Pakistan.

1974. Akhtar, *Pakistan J. Zool.*, 6(1 & 2): 101.

1980. Chhotani, *Tech. Mongr. Zool. Surv. India*, No. 4 : 9.

IMAGO (Fig. 101) Head reddish brown, postclypeus paler; anteclypeus white; antennae light brown; pronotum as dark as head; labrum and legs light brown with reddish tinge; wings almost white, anterior veins light brown; abdominal tergites reddish brown. Head with a few short hairs and scattered long bristles; labrum with a few bristles arranged in a row near tip and a few hairs in middle; pronotum with some short hairs and long bristles on margins and on disc; wings with a few hairs along costal margin. Head semicircular; length to base of mandibles 0.98-1.11, width 1.18-1.25 mm;

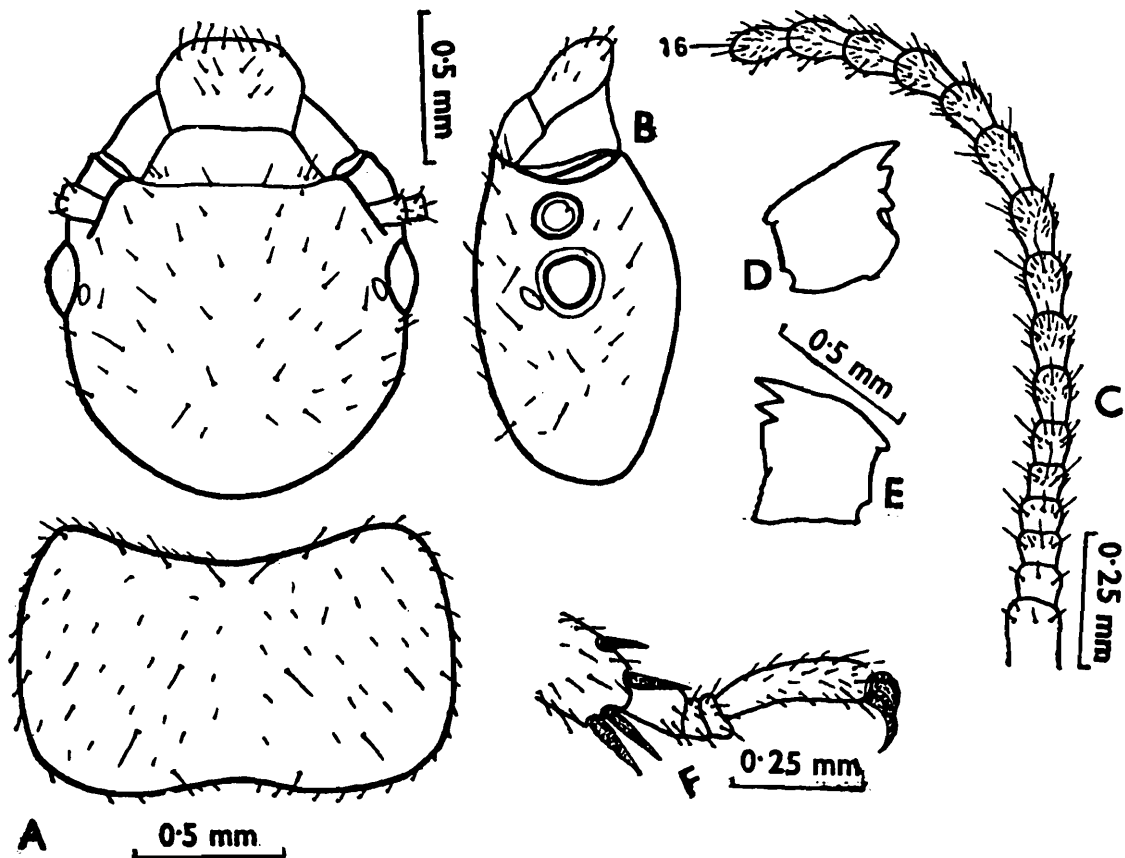

Fig. 101. *Postelectrotermes pasniensis*. Imago. (A) Head and pronotum, in dorsal view. (B) Head, in side view. (C) Antenna. (D) and (E) Left and right mandibles. (F) Lower part of middle leg, showing tibial spurs and the lateral spine. (After Akhtar 1974).

sides subparallel behind eyes; Y-suture with slightly indicated long arm. Eyes broadly oval, long diameter 0.23-0.26, short diameter 0.21-0.24 mm. Ocelli oval; length 0.07-0.09 mm; touching eyes but situated as far away as their diameter from lower margin. Antennae 15-16 segmented; in specimen with 16 segments; segment 2 slightly longer than 3, 4 slightly shorter than 3 and almost as long as 5. Anteclypeus trapezoid. Labrum dome-shaped, wider than long; lateral sides weakly convex; anterior margin almost straight in middle. Mandibles as in genus. Pronotum broader than head; maximum width 1.29-1.47, maximum length 0.70-0.76 mm; anterior margin shallowly concave; lateral sides weakly convex; posterior margin incurved medially. Forewing with all major veins arising independently at wing suture; media less sclerotized than radial sector and running close to radial sector than to cubitus. Tibial spurs 3: 3: 3; mid-tibia with a prominent spine a little above spurs; tarsi 4-jointed.

**SOLDIER (Fig. 102):** Head light reddish brown, slightly paler posteriorly; labrum light brown, with reddish tinge; mandibles reddish brown near base, dark brown to black distally; antennae pale brown; pronotum slightly paler than head; legs and abdomen yellowish brown. Head sparsely hairy; labrum with a few bristles on anterior margin and some on body; postmentum with a few long bristles in anterior third and a few short hairs in posterior half; pronotum with a few short hairs and long bristles on margins and on disc. Head elongate, rectangular; length to mandible-base 1.80-3.19, width 1.28-1.71 mm; sides substraight; posterior margin almost straight; Y-suture present; frons weakly sloping in front, with lateral sides a little below antennal carinae distinctly wrinkled. Eyes oval, large, margins not distinct. Antennae 13 to 15-segmented; segments 2 and 3 subequal; 4 shortest. Labrum dome-shaped, wider than long, lateral sides weakly convex. Mandibles long, stoutly built, basal humps distinct; length of left mandible 1.12-1.51 mm; left mandible with 5 marginal teeth, first and second well developed, third, fourth and fifth weakly developed; right with two marginal teeth. Postmentum long, club-shaped, widest anteriorly, narrowest below middle; length 1.22-2.48; maximum width 0.67-0.91, minimum width 0.20-0.28 mm. Pronotum wider than head; maximum width 1.25-2.10 mm, maximum length 0.70-1.12 mm; anterior margin deeply concave; lateral sides weakly convex; posterior margin distinctly emarginate in middle. Tibial spurs 3: 3: 3; middle tibia with a large, outer spine above apical spurs; tarsi 4-jointed.

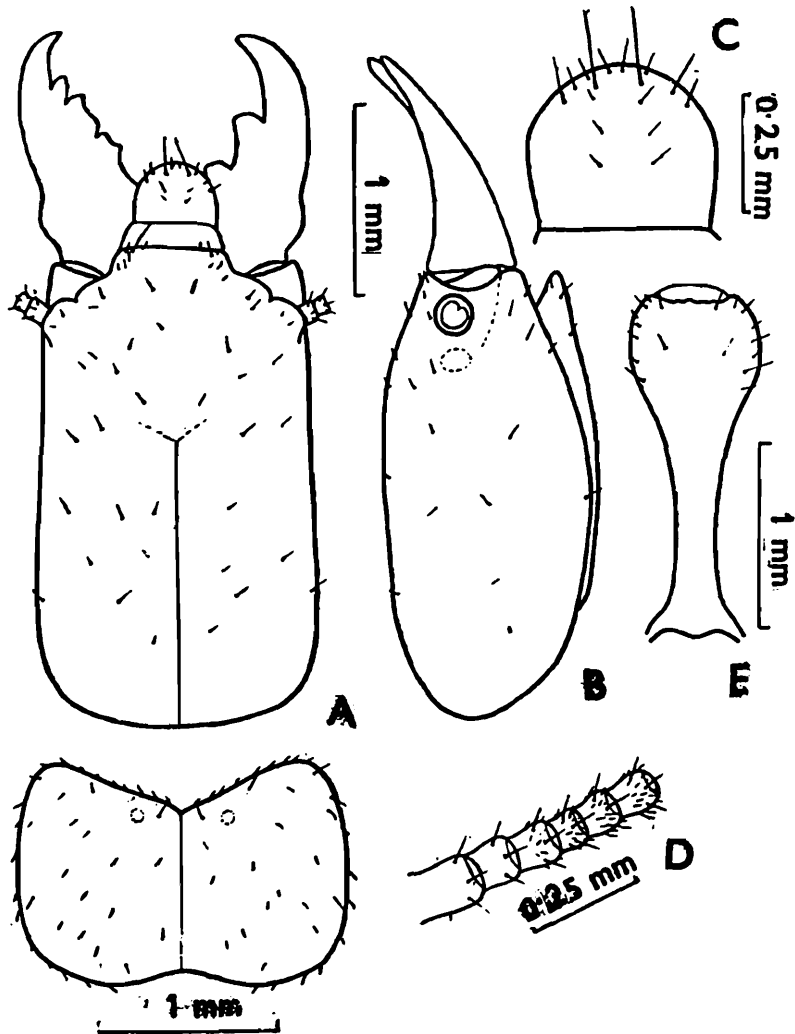

Fig. 102. *Postelectrotermes pasniensis*. Soldier. (A) Head and pronotum, in dorsal view. (B) Head, in side view. (C) Labrum. (D) Basal part of antenna. (E) Postmentum. (After Akhtar 1974).

*Distribution* : Pakistan : Pasni and Gwadar (Baluchistan).

*Biology* : This species has been collected from *Ficus*, *Acacia* and *Zizyphus* trees and wooden pole. The damage to the trees is confined to dead portions. The insect makes longitudinal galleries in which loose faecal pellets are found. The imagos have been collected from the nests in the month of March (Chaudhry and Ahmad 1972).

### 10. *Postelectrotermes pishinensis* (Ahmad)

(Fig. 103)

#### 1. *Neotermes pishinensis* Ahmad:

1955. Ahmad, *Biologia*, (Lahore), 1(2): 206-207. Soldier. Holotype: S, in Zool. Dept., Panjab Univ., Lahore. Type-locality: Pishin (District Quetta-Pishin), Pakistan.

1958. Ahmad, *Biologia*, (Lahore), 4 (1 & 2) : 42.

1979. Roonwal, *Termite Life and Termite Control in Tropical South Asia* : 116. Jodhpur (Sci. Publ.)

#### 2. *Postelectrotermes pishinensis* (Ahmad):

1961. Krishna, *Bull. Am. Mus. nat. Hist.*, 122(Art. 4): 321.

1965. Roonwal and Maiti, *Indian J. Ent.*, 27(3): 255, 261.

1971. Roonwal and Verma, *Indian Zoologist*, 2: 88, 89.

1974. Akhtar, *Pakistan J. Zool.*, 6(1 & 2): 101.

1975. Chhotani, *Zool. Anz.*, 194 (1 & 2): 112, 115, 117.

1980. Chhotani, *Tech. Monogr. Zool. Surv. India*, No. 4 : 9.

1984. Bose, *Occ. Pap. Rec. zool. Surv. India*, No. 49: 15, 18, 269.

IMAGO : Unknown.

**SOLDIER (Fig. 103) :** Head light reddish brown, anteriorly a little darker; mandibles basally dark reddish brown, apically blackish; eyes whitish; pronotum brownish yellow; legs and abdomen pale creamish. Head sparsely pilose; labrum with a few long hairs on tip; postmentum with a few long and short hairs in anterior half; pronotum with scattered short hairs. Head-capsule subrectangular, sides converging anteriorly; one-and-a-half times as long as broad; length to mandible-base 2.11-2.25, maximum width 1.41-1.62 mm; frons sloping anteriorly. Eyes oval; long diameter subequal to scape of antennae. Antennae 16-segmented; segment 3 one-and-a-half times that of 4; 2nd slightly shorter than 3rd. Labrum broader than long, broadly tongue-shaped with subparallel sides. Mandibles fairly long, stout; left mandible with 5 marginal teeth; right with two well separated marginal teeth. Postmentum club-shaped, long; length 1.48-1.66, maximum width 0.70-0.78 mm; twice as broad anteriorly as at waist; narrowest a little below middle. Pronotum broader than head; maximum width 1.72-1.81, maximum length 0.83-1.04 mm; anterior margin weakly concave; antero-lateral corners slightly curved; posterior margin substraight.

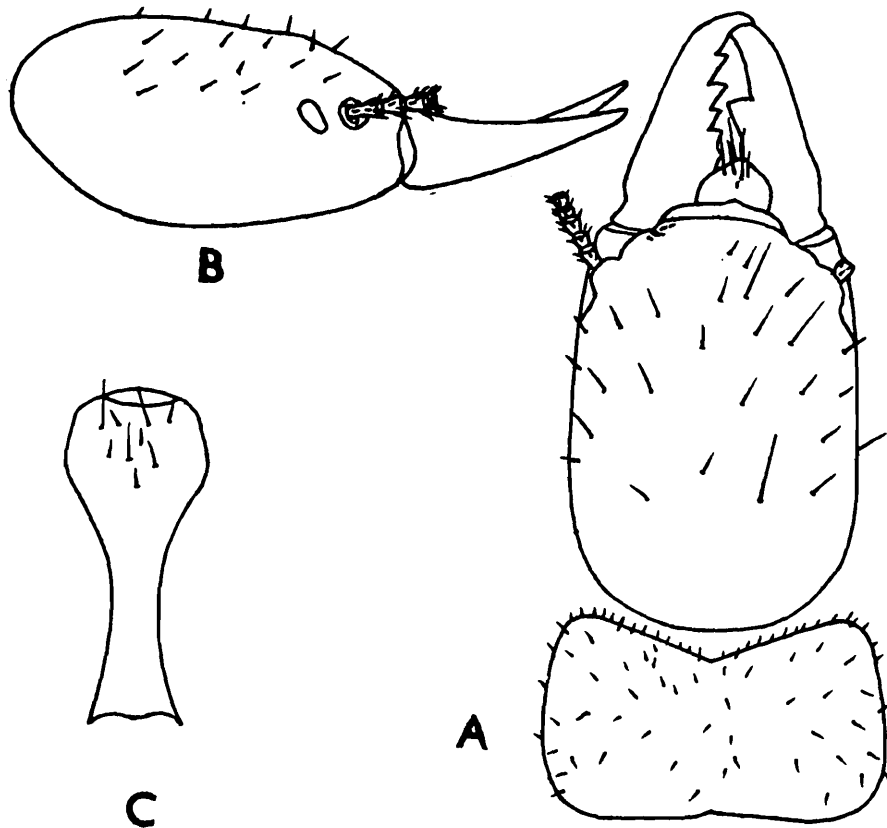

Fig. 103. *Postelectrotermes pishinensis*. Soldier. (A) Head and pronotum, in dorsal view. (B) Head, in side view. (C) Postmentum. (Redrawn from Ahmed 1955).

PSEUDOWORKER : Unknown.

*Distribution* : PAKISTAN : Pishin (District Quetta-Pishin), Baluchistan.

*Biology* : This species was collected from a living willow tree (Ahmad, 1955).

#### Genus 4. *Neotermes* Holmgren

1. Subgenus *Neotermes* (of *Calotermes*) Holmgren :

1911. Holmgren, *K. Sv. Vetensk. Akad. Handl.*, 46(6): 53-54.

1913. Holmgren, *K. Sv. Vetensk. Akad. Handl.*, 50(2): 36-37.

2. Genus *Neotermes* Holmgren :

1912. Silvestri, *Ann. Mus. Civ. Stor. Nat. Genova*, (3) 5 (45): 212.

1949. Snyder, *Smiths. misc. Colls.*, 112: 21, 359.

1958. Ahmad, *Biologia*, Lahore, 4 (1 & 2): 36.

1960. Roonwal and Sen-Sarma, *Contrib. Syst. Orient. Termites* (I.C.A.R. Ent. Mongr. 1): 97, 98, 99, 137-143. (Synonymy, characters, oriental species).
1961. Krishna, *Bull. Am. Mus. nat. Hist.*, 122(Art. 4) : 314, 315, 316, 317, 321-325, 383-384, 385, 389. (Synonymy, characters, species included).
1969. Weesner, In *Biology of Termites* Vol. 1: 27.
1970. Krishna, In *Biology of Termites* Vol. 2: 132, 133.
1970. Roonwal, In *Biology of Termites* Vol. 2: 319, 322-324.
1965. Bouillon and Mathot, *Zooleo*, No. 1: 12, 17-18, 37-38, 80.
1966. Bouillon and Mathot, *Zooleo*, No. 1 (Suppl. 1): Table of generic measurements.
1966. Roonwal and Maiti, *Treubia*, 27(1): 71-73.
1971. Bouillon and Mathot, *Zooleo*, No. 1 (Suppl. 2) : Table of generic measurements.
1972. Chaudhury and Ahmed, *Termites of Pakistan, (Rep. PL-480 Project)*: 1-2.
1973. Chhotani and Bose, *Zool. Anz.*, 190(3/4): 232, 234.
1975. Chhotani, *Zool. Anz.*, 194(1/2): 112-113, 115, 116, 117, 121.
1975. Akhtar, *Bull. Dept. Zool. Univ. Panjab (N.S.)*, Art. 7: 4, 184.
1975. Sen-Sarma et al. *Wood Destroying Termites (Final Tech. Rep. PL-480 Proj)*: 7, 9, 34, 36, 169.
1977. Roonwal and Chhotani, *Ent. Basil.*, 2: 39, 42, 43, 44.
1977. Roonwal, *Proc. zool. Soc.*, 28: 31, 32, 33-34, 37.
1978. Roonwal and Rathore, *Zool. Anz.*, 200 (3/4): 219, 228, 229, 230-231.
1979. Sen-Sarma and Thakur, *Indian For. Rec. (N.S.) Ent.*, 13(1): 4.
1980. Chhotani, *Tech. Monogr. Zool. Surv. India*, No. 4: 3, 9, 12.
1983. Roonwal, *Proc. Indian natn. Sci. Acad.*, (B), 49 (5): 362, 373, 378.
1984. Bose, *Occ. Pap. Rec. Zool. Surv. India*, No. 4: 14, 18, 21.
1986. Grasse', *Termitologia* Vol. 3: 512.

Type of genus : *Termes castaneus* Burmeister.

### 1. Characters of Genus *Neotermes*

*Imago* : Moderately large; total body-length without wings 7-12 mm. Head and body pale brown to dark brown, hairy. Head-capsule generally suboval to rounded. Eyes large, 0.46-0.78 mm in diameter. Ocelli either touching or slightly separated from eyes. Antennae 12 to 21-segmented; length of 3rd segment variable. Postclypeus darker than frons, flat,

subrectangular. Anteclypeus translucent, trapezoidal. Labrum subsquarish. Mandibles each with an apical and 2 marginal teeth. Left mandible with 1st (1st + 2nd of some authors) marginal slightly shorter than apical and with posterior margin equal to anterior margin of 2nd (3rd of some authors). Right mandible with 1st marginal slightly shorter than apical and 2nd with posterior margin subequal to molar plate. Pronotum slightly narrower to slightly wider than head with eyes. Legs long, slender; tibiae each with 3 apical spurs; tarsi 4-jointed; empodium present generally, but sometimes absent. Wings fairly long; wing microsculpturing consists of papillae, pimples and tubercles, the last mentioned i.e. tubercles present in some species while absent in others. All veins except cubitus thick, strongly sclerotized, prominent and running close to each other anteriorly; cubitus weaker and running medially. Forewing: All veins arising separately from scale. Costa running along anterior margin all through length of wing; subcosta short, joining costa a little outside scale. Radius meeting costa-subcosta at middle or a little before middle. Radial sector with 5-7 branches to costal border and running upto distal end. Media running parallel to and close to radial sector all through length. Cubitus with 11-15 branches to posterior margin. Hindwing : Venation as in forewing in general; subcosta fused with costa; radius meeting costa-subcosta before to beyond middle of wing; radial sector as in forewing; media arising from radial sector in wing membrane from near about anterior one-fourth to a little proximal to middle.

*Soldier* : Generally large, total body length c 8-16 mm. Head brownish; body creamish white to pale straw coloured. Head-capsule subrectangular, sides subparallel; frons sloping anteriorly at about 45° angle and depressed medially; Y-suture present or absent. Eyes generally translucent, white and small; sometimes prominent and pigmented black and sometimes hardly discernible. Ocelli absent or present as small, whitish spots at end of lateral arms of Y-suture. Antennae with 12 to 19 segments; 3rd segment as large as 2 or longer and modified; antennal carina weak or quite well developed. Postclypeus flat, rectangular, faintly demarcated from frons; anteclypeus, hyaline, trapezoidal. Labrum subsquarish, rounded at anterior margin. Mandibles strong and stout; either short or fairly long. Left mandible with 2-5 (generally 5) marginal teeth; right with 2 marginals. Postmentum

club-shaped, with a long, narrow stalk (waist); club fairly to strongly bilobed. Pronotum sub rectangular, narrower to broader than head; anterior margin weakly to fairly incurved, with or without median notch. Legs long slender; apical tibial spurs 3 on each leg; tarsi 4-jointed. Abdomen elongate; cerci 2-jointed.

*Pseudoworker* : Small to large; c 7-12 mm long. Head subcircular. Eyes present, ocelli absent. Antennae short, 14 to 17-segmented. Mandibles as in imago. Pronotum, legs and abdomen as in soldier.

## 2. *Distribution and Composition of Neotermes* (Fig. 94)

*Distribution* : Living : The genus is known from all the zoogeographical regions except the Palaearctic and Nearctic; two neotropical species, however, extend in distribution to the southern U.S.A. and one oriental species overlaps into Palaearctic.

Fossil : Eocene of France.

*Composition* : Snyder (1949) catalogued 75 species of the genus from the world, out of which 23 were from the oriental region including 7 from the Indian region. Emerson (1955) recognised 90 species (including 19 undescribed ones) comprising 22 from the Oriental Region. Roonwal and Sen-Sarma (1960) treated 28 species in their revision of oriental species of the genus and Krishna (1961) while revising the family Kalotermitidae recognised 90 (including 17 undescribed) species from the world with 21 from the oriental region. Chhotani (1975b) has taken into account 83 species of the genus from the world with 27 from the oriental region. Since Chhotani (1975b), 8 species have been described, thus a total of 91 species were known till recently including 23 from the Indian Region. Following is the list of the Indian Region species and subspecies taken into account and their distribution :

1. *Neotermes adampurensis* Akhtar. Bangladesh.
2. *N. andamanensis* Snyder. Andaman Islands, India.
3. *N. artocarpi* (Haviland). Burma, Indonesia.

4. *N. assmuthi* Holmgren. Southern India.
5. *N. bosei* Snyder (= *N. gardneri* Snyder). India (Uttar Pradesh, West Bengal), Bhutan.
6. *N. buxensis* Roonwal & Sen-Sarma. India (West Bengal).
7. *N. dhirendrai* Bose. Southern India.
8. *N. eleanorae* Bose. Southern India.
9. *N. fletcheri* Holmgren & Holmgren. India, Bangladesh.
10. *N. greeni* (Desneux). Sri Lanka.
11. *N. kalimpongensis* Maiti. India (West Bengal).
12. *N. kemneri* Roonwal & Sen-Sarma. Sri Lanka.
13. *N. keralai* Roonwal & Verma. Southern India.
14. *N. krishnai* Bose. Southern India.
15. *N. mangiferae* Roonwal & Sen-Sarma. Eastern India.
- 16a. *N. megaoculatus megaoculatus* Roonwal & Sen-Sarma. India.
  - b. *N. megaoculatus lakhimpuri* Roonwal & Sen-Sarma. India (Assam).
17. *N. microculatus* Roonwal & Sen-Sarma. India (Uttar Pradesh).
18. *N. nilamburensis* Thakur. Southern India.
19. *N. paratensis* Sen-Sarma & Thakur. India (Tripura).
20. *N. prosonneratae* Akhtar. Bangladesh.
21. *N. shimogensis* Thakur. India (Karnataka).
22. *N. venkateshwara* Bose. India (Tamil Nadu).

### 3. Keys to Indian Region Species of *Neotermes* IMAGOES

- 1(12). Head-width with eyes 1.5-1.77 mm; eyes smaller 0.45-0.60 mm
- 2(3). Ocelli not touching eyes (eye-ocellus distance 0.013-0.025 mm)..... *greeni*
- 3(2). Ocelli touching eyes
- 4(7). Wings weakly tuberculate
- 5(6). Pronotum almost as wide as head; wings shorter (forewing 11.7-12.15 mm); media in hindwing arising from radial sector at about proximal 1/5 of wing..... *fletcheri*

- 6(5).Pronotum wider than head; wings longer (forewing 14.0-15.2 mm);  
media in hindwing arising from radial sector a little before middle of  
wing..... *nilamburensis*
- 7(4).Wings not tuberculate
- 8(9).Media in hindwing arising from radial sector at proximal 1/3rd..... *andamanensis*
- 9(8). Media in hindwing arising from radial sector at about middle
- 10(11). Head smaller (head-width with eyes 1.50 mm)..... *assmuthi*
- 11(10). Head larger (head-width 1.60-1.70 mm)..... *eleanora*
- 12(1). Head-width with eyes 1.80-2.05; eyes generally larger, 0.57-  
0.73 mm
- 13(14). Ocelli slightly separated from eyes (eye-ocellus distance  
0.013 mm)..... *buxensis*
- 14(13). Ocelli touching eyes
- 15(22). Larger species : Head-width with eyes 1.90-2.05 mm
- 16(17). Eyes smaller (max. diameter 0.60 mm). Y-suture on head not  
clear. Pronotum length comparatively more (1.30 mm)..... *artocarpi*
- 17(16). Eyes larger (max. diameter 0.64-0.73 mm). Y-suture on head  
distinct. Pronotum length comparatively less (1.03-1.2 mm)
- 18(19). Head sides behind eyes bulging out. Pronotum emarginate at  
posterior margin *adampurensis*
- 19(18). Head sides behind eyes not bulging out. Pronotum substraight  
at posterior margin
- 20(21). Wings weakly tuberculate. Eyes rounded anteriorly; ocelli larger  
(0.25-0.30 mm long). Anterior margin of pronotum deeply incurved: *megaoculatus*  
*megaoculatus*
- 21(20). Wings not tuberculate. Eyes truncated anteriorly; ocelli smaller  
(0.20 mm long). Anterior margin of pronotum less so incurved..... *bosei*
- 22(15). Smaller species : Head-width with eyes 1.80-1.88 mm
- 23(24). Eyes truncated in front, smaller and further away from antennae  
[max. diameter 0.57-0.61, eye-antennal distance 0.05 (not 0.5 as in  
Akhtar, 1975) mm]. Pronotum light brown..... *prosonneratae*
- 24(23). Eyes rounded in front, larger and closer to antennae (max. dia-  
meter 0.60-0.63, eye-antennal distance 0.013-0.04 mm). Pronotum  
deep reddish brown..... *paratensis*

## SOLDIERS

- 1(2). Pronotum-width much less than head-width..... *fletcheri*
- 2(1). Pronotum-width subequal to or greater than head-width
- 3(4). Eyes smaller (0.10-0.15 mm long); eye-antennal distance one-and-a-half times that of max. diameter of eye..... *microculatus*
- 4(3). Eyes larger (0.17-0.40); eye-antennal distance one-half to equal to max. diameter of eye
- 5(8). Pronotum deeply incurved at anterior margin and prominently notched medially
- 6(7). Smaller species: Head-length to base of mandibles 2.52-2.82, width 1.86-2.04 mm; antennae generally 13-segmented (occasionally 14-segmented), antennal carina well developed..... *kemneri*
- 7(6). Larger species: Head-length 2.79-3.5, width 2.07-2.40 mm; antennae 14-16 segmented, antennal carina weakly developed..... *greeni*
- 8(5). Pronotum weakly incurved and either not notched or indistinctly notched medially
- 9(20). Larger species: Head-length to base of mandibles 3.60-5.0; head width 2.40-3.00 mm
- 10(17). Eyes larger (max. diameter 0.30-0.40 mm)
- 11(12). Head larger (length to base of mandibles 4.1-5.0, width 2.6-3.0 mm); mandibles shorter (index Mandible-length/Head-length 0.42-0.54)..... *megaoculatus*  
*lakhimpuri*
- 12(11). Head smaller (length to base of mandibles 3.64-4.5, width 2.43-2.88 mm; mandibles comparatively longer (index 0.48-0.65)
- 13(14). Head sides narrowing posteriorly; mandibles shorter in relation to head (index Mandible-length/Head-length to base of mandibles 0.48-0.53)..... *buxensis*
- 14(13). Head sides straight; mandibles longer in relation to head (index Mandible length/Head-length to base of mandibles 0.50-0.65)
- 15(16). Mandibles stouter and thicker; margin between 2nd and 3rd marginal teeth of left mandible shorter; epicranial suture indistinct.. *megaoculatus*  
*megaoculatus*
- 16(15). Mandibles comparatively thinner; margin between 2nd and 3rd marginal teeth of left mandible longer; epicranial suture distinct..... *kalimpongensis*
- 17(10). Eyes smaller (max. diameter 0.17-0.30 mm)

- 18(19). Mandibles shorter in comparison to head-length to base of mandibles (index Mandible-length/Head-length 0.48-0.49); Y-suture distinct; pronotum fairly concave at anterior margin..... *adampurensis*
- 19(18). Mandibles longer in comparison to head-length to base of mandibles (index 0.56-0.62); Y-suture indistinct; pronotum weakly concave at anterior margin..... *artocarpi*
- 20(9). Smaller species: Head-length to base of mandibles 2.67-4.00 (generally less than 3.60); head-width 2.00-2.50 mm
- 21(36). Head-Capsule wider in comparison to length, width 2/3rd of length or more (index Width/Length to base of mandibles 0.61-0.83)
- 22(25). Mandibles shorter (mandible-length 1.50-1.68 mm)
- 23(24). Antenna 17-segmented; mandibles longer in relation to head (index Mandible-length/Head-length 0.53-0.57); postmentum more swollen at club and narrower at waist; anterior angles of pronotum broader..... *andamanensis*
- 24(23). Antenna 13-16 segmented; mandibles shorter in relation to head (index 0.47-0.53); postmentum less swollen at club and broader at waist; anterior angles of pronotum narrower..... *mangiferae*
- 25(22). Mandibles longer (mandible-length 1.70-2.20 mm)
- 26(27). Antenna with 12 segments; mandibles generally longer (1.95-2.00 mm)..... *krishnai*
- 27(26). Antenna with 13 to 16-segments; mandibles generally shorter (1.7-2.0 mm)
- 28(33). 3rd segment of antenna longer than 2nd and strongly sclerotised
- 29(30). Mandibles in comparison to head longer (index Mandible-length/Head-length 0.61-0.66); postmentum club greatly swollen and strongly bilobed..... *assmuthi*
- 30(29). Mandibles shorter (index Mandible-length/Head-length 0.51-0.60); postmentum club less swollen and not strongly bilobed
- 31(32). Antenna with 13-14 segments; eyes smaller (long diameter 0.20-0.28 mm)..... *venkateshwara*
- 32(31). Antenna with 15-16 segments; eyes larger (long diameter 0.40-0.55 mm)..... *shimogensis*
- 33(28). 3rd segment of antenna either shorter or slightly longer than 2nd and not so sclerotised
- 34(35). Eyes smaller (0.18 mm long); pronotum comparatively longer (1.05-1.58 mm long)..... *keralai*
- 35(34). Eyes larger (0.20-0.30 mm long); pronotum comparatively shorter (0.90-1.26 mm)..... *bosei*

- 36(21). Head-capsule narrower in comparison to length, width less than to about 2/3rd of length (index Width/Length to base of mandibles 0.56-0.67)
- 37(38). Head-smaller (length to base of mandibles 2.9-3.2, width 1.94-2.05 mm) ..... *paratensis*
- 38(37). Head larger (length to base of mandibles 3.2-3.84, width 2.00-2.30 mm)
- 39(42). Segment 3 of antenna one-and-a-half times as long as 2, strongly sclerotised
- 40(41). Eyes larger (0.30 mm); Y-Suture distinct; head comparatively wider (index Width/Length 0.66); postmentum narrow at waist ..... *dhirendrai*
- 41(40). Eyes smaller (0.17-0.22 mm); Y-Suture present but indistinct; head comparatively narrower (index Width/Length 0.56 - 0.63); postmentum wider at waist..... *prosonneratae*
- 42(39). Segment 3 of antenna subequal to or slightly longer than 2, less so sclerotised
- 43(44). Club of postmentum swollen and prominently bilobed; 3rd segment of antenna longer than 2nd..... *nilamburensis*
- 44(43). Club of postmentum not swollen and weakly bilobed; 3rd segment of antenna subequal to 2nd ..... *eleanorae*

### 11. *Neotermes adampurensis* Akhtar (Figs. 104, 105)

#### 1. *Neotermes adampurensis* Chaudhury and Ahmad :

1972. Chaudhury and Ahmad, *Termites of Pakistan* (Final Tech Rept. PL 480 Progr.): 1-2. (Nom. nud).

#### 2. *Neotermes adampurensis* Akhtar :

1975. Akhtar, *Bull. Dept. Zool. Panj. Univ., Lahore*, Art. 7: 5-9. Im, S. Holotype : S, in Zoology Dept., Panjab Univ., Lahore. Type-locality: Adampur, Bangladesh.

**IMAGO** (Fig. 104) : Head reddish brown, frons and postclypeus paler; labrum, legs and abdomen yellowish brown; antennae, pronotum and wings light brown. Head and body sparsely pilose. Head-capsule ovoid, weakly converging anteriorly; broader than long (length to lateral base of mandibles 1.7, width with eyes 2.01 mm); Y-suture distinct. Eyes subcircular (maximum diameter 0.64, minimum diameter 0.59 mm); eye-antennal distance 0.04 mm. Ocelli suboval (length 0.26, width 0.21 mm); situated close to and touching ocular sclerite of eyes broadly. Postclypeus not well

differentiated from frons; with a few hairs on body and anterior margin; anteclypeus trapezoidal, anteriorly truncate and concave. Antennae with 18 segments, segment 3 shorter than 2. Labrum broader than long, with a row of bristles near substraight anterior margin and a few hairs near middle.

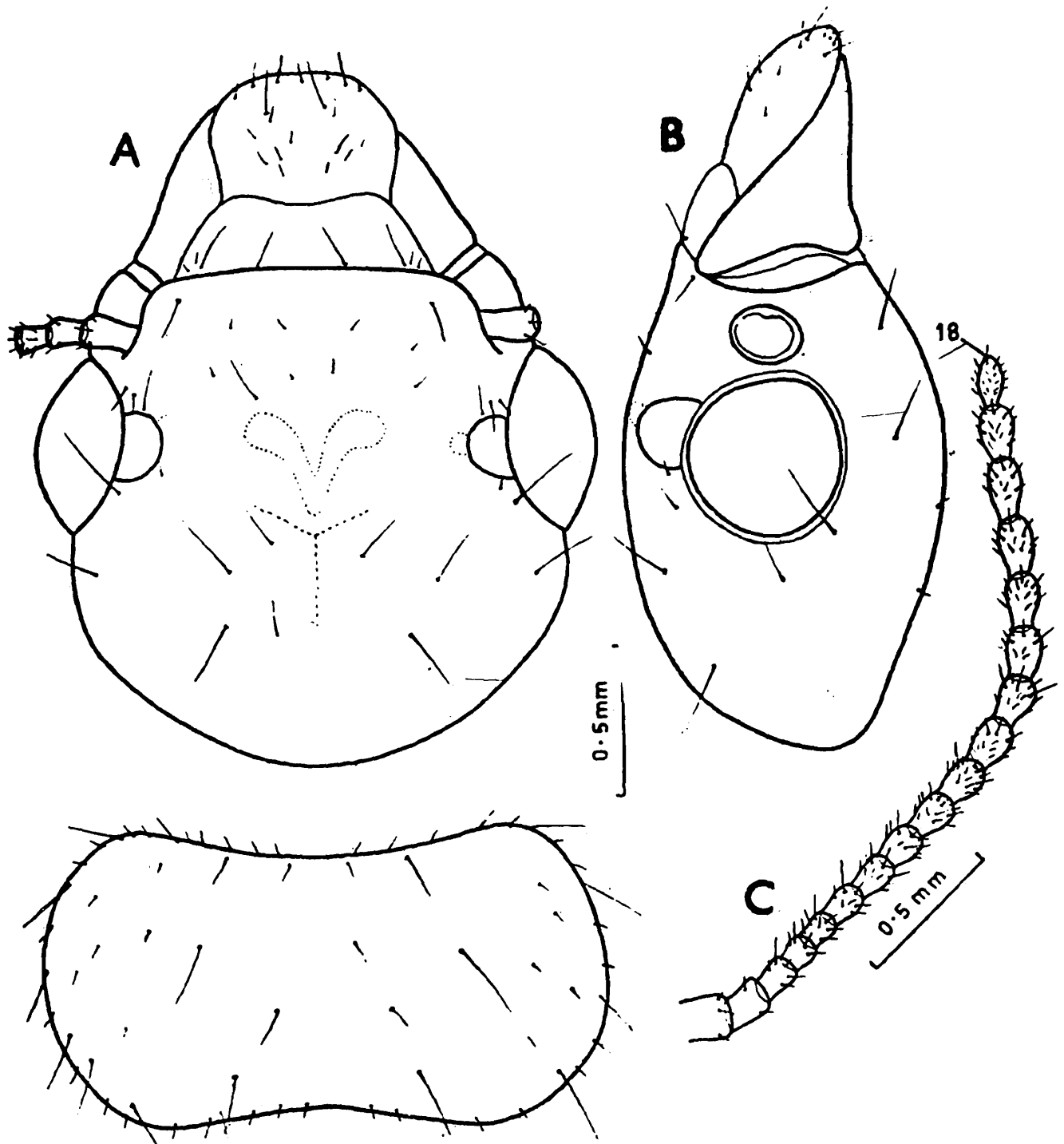

Fig. 104. *Neotermes adampurensis*. Imago. (A) Head and pronotum, in dorsal view. (B) Head, in side view. (C) Antenna. (After Akhtar, 1975).

Mandibles as in genus. Pronotum subrectangular (width 2.08, length 1.03 mm); width a little more than head-width with eyes; anterior margin concave; posterior margin incurved. Wings with short hairs along costal margin; forewing veins arising independently at wing suture, media and radial sector strongly sclerotized and running parallel; cubitus weak and unsclerotised. Apical tibial spurs 3:3:3, arolium present.

**SOLDIER** (Fig. 105) : Head capsule and labrum light reddish brown; frons and postclypeus darker; mandibles basally reddish brown, distally blackish; antennae basally reddish brown, distally lighter; pronotum, abdomen and tibiae brownish yellow; femora and coxae whitish. Head sparsely and pronotum fairly, pilose. Head-capsule subrectangular, much

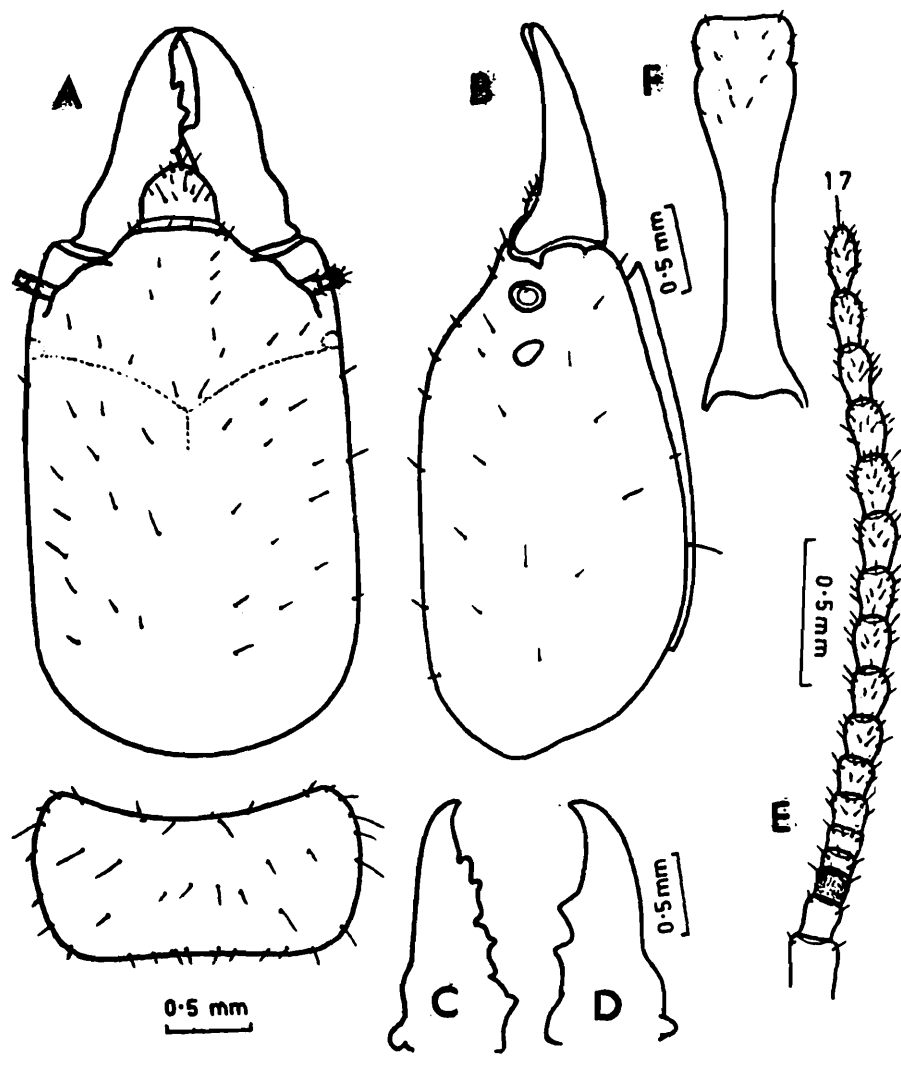

Fig. 105. *Neotermes adampurensis*. Soldier. (A) Head and pronotum, in dorsal view. (B) Head, in side view. (C) and (D) Left and right mandibles. (E) Antenna. (F) Postmentum. (After Akhtar 1975).

longer than broad, (length to base of mandibles 3.63-3.99, width 2.40-2.71 mm); broadest in posterior part, sides subparallel, converging anteriorly; frons sloping anteriorly; Y-suture distinct. Eyes whitish, suboval (length 0.17-0.27, width 0.10-0.17 mm), narrow end pointing downwards; eye-antennal distance 0.22-0.24 mm. Ocelli not visible. Labrum broader than long, subparallel-sided; anteriorly converging to a broadly rounded tip. Antennae with 15-17 segments; segment 3 strongly sclerotized, as long as 2; 4 shortest. Postclypeus not differentiated from frons, with a few hairs; anteclypeus narrow, apilose. Mandibles short, robust; less than half of head-length to base of mandibles (mandible-length 1.89-1.96 mm; mandibular-head index 0.48-0.49); basally humped; left mandible with 5 and right with 2 marginal teeth. Postmentum long (length 2.76-3.07 mm), club-shaped, anterior part broader (maximum width 0.76-0.87 mm), weakly bilobed; thence narrowing to a long waist, width at waist 0.35-0.42 mm. Pronotum subrectangular, as wide as head (width 2.37-2.71, length 0.99-1.12 mm); anterior margin fairly concave; posterior margin substraight. Apical tibial spurs 3:3: 3, tarsi 4-jointed.

*Distribution* : BANGLADESH : Adampur. Known only from type-locality.

*Biology* : This species is recorded from a living Jack fruit tree, *Artocarpus integrifolia*, in humid part of Bangladesh, making longitudinal galleries in dead decaying branch. The infestation extends to living portion also. Imagoes were collected from nest in the month of February.

## 12. *Neotermes andamanensis* Snyder

(Figs. 106, 107)

*Neotermes andamanensis* Snyder :

1933. Snyder, *Proc. U.S. natn. Mus.*, **82**(Art. 16): 2. Holotype: Dealate ♀ in British Museum (Natural History), London. Type locality; North Andaman Island.

1949. Snyder, *Smiths. misc. Colls.*, **112**: 22.

1953. Roonwal and Pant, *Indian For. Leaflet (Ent.)*, No. 121(3): 49.

1960. Roonwal and Sen-Sarma, *Contrib. Syst. Orient. Termites* (ICAR Ent. Monogr. 1): 139, 140, 144-145.

1961. Krishna, *Bull. Am. Mus. nat. History*, **122** (Art 4): 325.

1970. Roonwal and Bose, *Rec. zool. Surv. India*, **62** (3 & 4): 116.

1975. Chhotani, *Zool. Anz.*, **194** (1/2): 117.

1975. Sen-Sarma et al., *Wood Destroying Termites (Final Tech. Rep. PL. 480 Project)*: 64.

1980. Bose, *Rec. zool. Surv. India*. 77: 93-99.

**IMAGO (Fig. 106)** : Head capsule reddish brown; antennae and labrum pale brown; pronotum yellowish brown, somewhat darker posteriorly; abdominal tergites paler than head-capsule; sternites pale yellowish, distal 3-4 pale yellowish brown; legs golden yellow; wings pale brown; all veins except cubitus, brown. Head and body fairly hairy. Total length with wings 14.00-14.6, without wings 7.4-7.9 mm. Head-capsule flat, subcircular; width with eyes (1.70-1.77 mm) more than length to base of mandibles (1.47-1.57 mm); Y-suture present; a pale, V-shaped mark in between lateral arms of suture and two pale, round spots, one on either side, between the antennae, present; frons slightly sloping in front. Eyes fairly large, round (max. diameter 0.53-0.60 mm); situated very close to antennae and well separated from lateral margin. Ocelli oval (max. diameter 0.23-0.30, min. diameter 0.13-0.17 mm), translucent; touching the eyes and almost as far from antennae as their long diameter. Clypeus faintly divided into ante- and postclypeus; postclypeus pale yellowish, flat and with a few bristles; anteclypeus subtrapezoidal, apilose. Antennae with 17 segments; segment 1 long, cylindrical; 2 about half of 1; 3 slightly shorter than 2, somewhat more strongly chitinized. Labrum broadly dome-shaped; broader than long. Mandibles as in genus. Pronotum flat; almost as wide as head with eyes (length 0.90-1.10, width 1.70-1.73 mm); anterior margin fairly incurved; antero-lateral corners narrower than postero-lateral ones; posterior margin substraight or faintly incurved. Legs short; tibia somewhat darker than femora, each with 3 apical spurs; tarsi 4-jointed; empodium between claws present. Wings transparent, not tuberculate, faintly brownish; anterior veins prominent, thick and brownish; running close to each other; cubitus faint and further removed; membrane between media and cubitus with weak reticulation. Forewing : Length 12-12.5 mm. Venation as in genus; subcosta uniting with costa at about 1/5th of wing membrane; radius joining costa at about middle or a little before middle; radial sector giving off 6 oblique branches to costa; media connected to radial sector by 6-7 evanescent branches; cubitus with 13-15 branches to posterior margin. Hindwing : Length 11.2-11.5 mm. Radius fusing with costa-subcosta at about middle; radial sector as in forewing; media arising from radial sector a

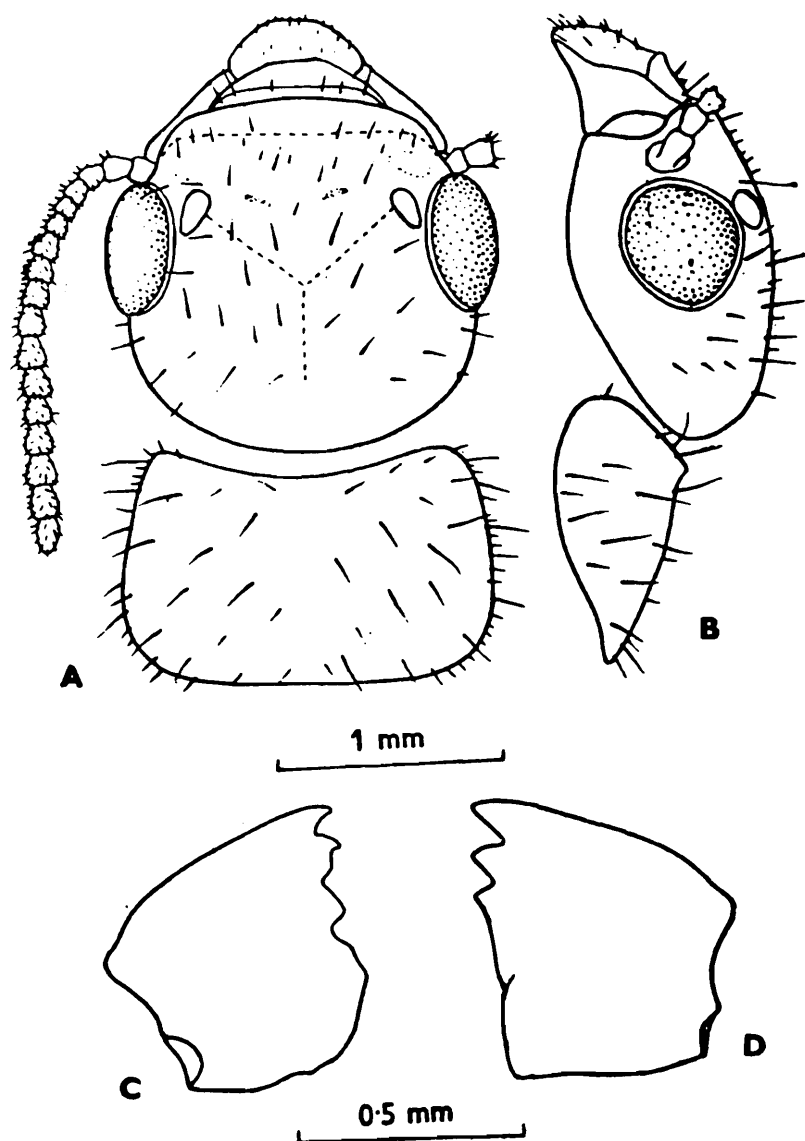

Fig. 106. *Neotermes andamanensis*. Imago. (A) Head and pronotum, in dorsal view. (B) Same, in side view. (C) and (D) Left and right mandibles. (After Bose, 1980).

little before 1/3rd of wing-membrane, otherwise as in forewing; cubitus with about 12 branches to posterior margin. Abdomen oblong; anterior tergites with a row of long bristles near posterior margin; distal tergites somewhat more hairy; cerci 2-jointed, 0.20 mm long; styli (in male) single-jointed, 0.17 mm long.

**SOLDIER (Fig. 107)** : Head-capsule yellowish brown, frons somewhat darker; labrum and antennae light brownish; antennae paler distally; mandibles blackish, dark reddish brown basally; pronotum yellowish, anterior and posterior margins darker; legs pale yellowish; abdomen creamy white to pale yellowish. Head-capsule and pronotum fairly hairy, with long and short bristles; meso- and metanota and abdominal tergites with a row of

long bristles in middle and several short hairs, visible only in reflected light. Total body-length 10.0-11.5 mm. Head-capsule flat, subrectangular (length to base of mandibles 2.67-3.03, width 2.10-2.17 mm); length about 1.3 to 1.45 times of width; epicranial suture fairly marked; frons inclining in front at an angle of about  $45^\circ$ . Eyes oval, unpigmented; 0.23-0.33 mm long and 0.15-0.23 mm wide. Postclypeus slightly darker than frons and demarcated from it by a short line at base of mandibles, pilose near anterior margin; anteclypeus thin, strip-like, apilose. Labrum broad, subrectangular to subsquarish (length 0.23-0.40, width 0.50-0.57 mm); anterior margin weakly curved. Antennae with 14 segments; carinae prominent; segment 1 cylindrical, more than half covered by carina; 2 half of 1; 3 longer than 2, pyriform and somewhat more strongly chitinized; 4 shortest. Mandibles strong and robust; left mandible with 5 and right with 2, marginal teeth (Fig. 107A); fairly humped basally; length 1.53-1.60 mm; slightly longer than half of head-length (index Mandible length/Head length 0.53-0.57).

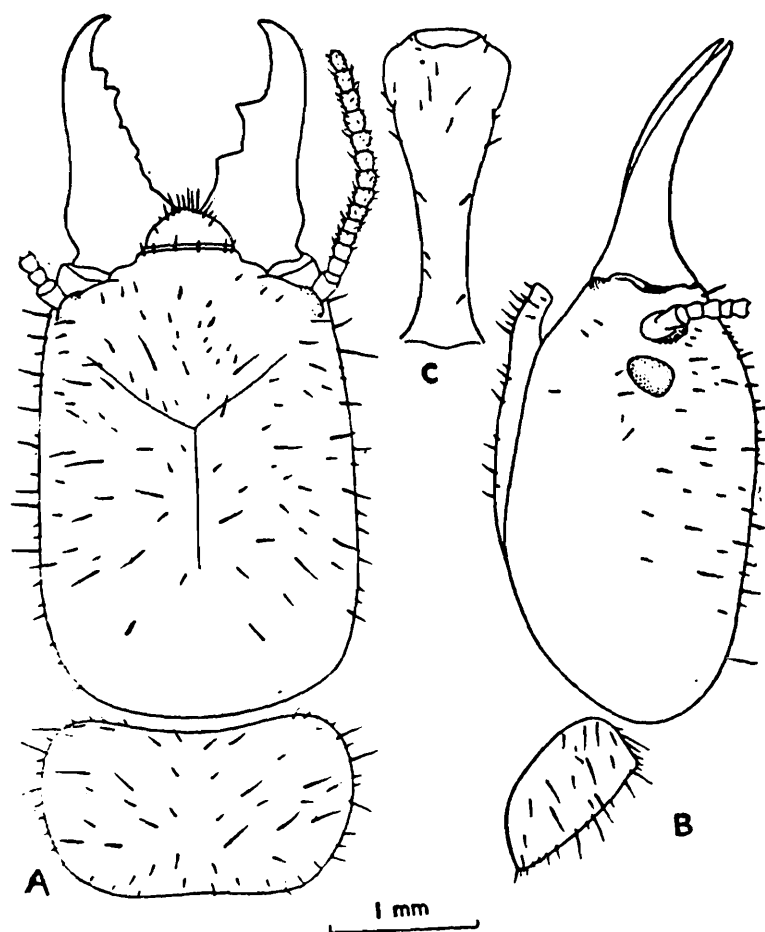

Fig. 107. *Neotermes andamanensis*. Soldier. (A) Head and pronotum, in dorsal view. (B) Same, in side view. (C) Postmentum. (After Bose 1980).

Postmentum long, club-shaped; anterior wider portion weakly divided into 2 halves and about two-and-a-half times as wide as at waist (length 1.93-2.33, max. width 0.73-0.83, width at waist 0.33 mm). Pronotum flat, subrectangular; almost as wide as head (length 1.03-1.17, width 2.00-2.23 mm); anterior margin fairly incurved. Legs short and stout; each tibia with 3 apical spurs; tarsi 4-jointed. Abdomen oblong hairy; cerci 2-jointed, 0.20 mm long; styli single-jointed, finger-like, 0.20 mm long.

**PSEUDOWORKER** : Head-capsule, antennae and labrum pale yellow; body and legs creamy white. Head and body moderately hairy. Total body-length 6.60-9.30 mm. Head-capsule subcircular; broader than or as broad as length to base of mandibles (length 1.57-1.72, width 1.67-1.80 mm). Eye spots unpigmented; oval to subcircular; discernible only in strong light. Antennae with 14 segments; segment 2 half of 1; 3 shorter than 2; 4 shortest. Postclypeus flat, subrectangular, with a few hairs on side margins; anteclypeus, apilose, narrow, strip-like. Mandibles as in genus. Pronotum as wide as head (length 0.87-1.0, width 1.67-1.90 mm). Legs and abdomen as in soldier.

**Distribution** : INDIA : Andaman Islands : North Andamans (Mayabunder) and South Andamans (Humphrygunj).

**Biology** : Attacks decaying trees and logs of wood. The alates have been collected in the month of March from a colony in a log.

### 13. *Neotermes artocarpi* (Haviland) (Figs. 108, 109)

1. *Calotermes artocarporum* Haviland and Sharp :

1896. Haviland and Sharp, *Trans. ent. Soc. Lond.*, 1896: 589-591. (Nom. nud.).

2. *Calotermes artocarpi* Haviland :

1898. Haviland, *J. Linn. Soc. Lond. (Zool.)*, 26(169): 376-377. Im, S. Syntypes: in Zoology Museum, Cambridge University, Cambridge (England). Type-locality: Sarawak, Borneo, Malaysia.

3. *Calotermes (Neotermes) artocarpi* Haviland :

1913. Holmgren, *K. Sv. Vet. Akad. Handl.*, 50(20): 39-40.

1914. Holmgren, *Zool. Jb.*, 36(2-3): 233.

4. *Neotermes artocarpi* Haviland :

1949. Snyder, *Smiths. misc. Colls.*, 112: 22.

1960. Roonwal and Sen-Sarma, *Contrib. Syst. Orient. Termites* (ICAR Ent. Monogr. 1): 140, 143, 145-148, 261, 262, 332-335 (Pls. 38, 39).

1961. Krishna, *Bull. Am. Mus. nat. Hist.*, 122 (Art. 4): 325.

1975. Chhotani, *Zool. Anz.*, 194(1/2): 117.

**IMAGO** (Fig. 108) Head-capsule dark brown with reddish tinge; antennae and labrum much paler; pronotum dark brown; legs and abdomen paler than head. Fairly pilose with long hairs. Total body-length 9.5 mm (10.5 mm vide Havilqnd, 1898 and Holmgren, 1913). Head-capsule oval

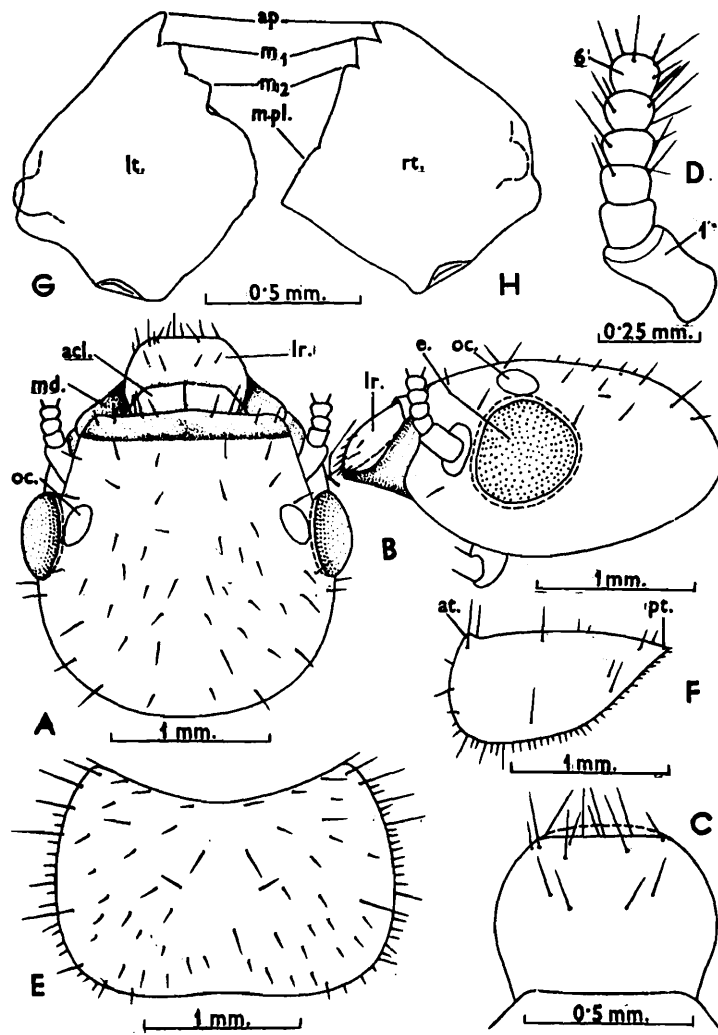

Fig. 108. *Neotermes artocarpi*. Imago (A-F) and Pseudoworker (G-H). Sarawak, Borneo (Kalimanatan). (A) head, in dorsal view. (B) Same, in side view. (C) Labrum. (D) Basal part of antenna. (E) Pronotum, in dorsal view. (F) Same, in side view. (G) Left mandible. (H) Right mandible.

acl., anteclypeus; ap., apical teeth of mandibles; at., anterior; e., eye; lr., labrum; lt., left; m<sub>1</sub> - m<sub>2</sub>, first and second marginal teeth of mandibles; m.pl., molar plate; md., mandible; oc., ocellus; pt., posterior; rt., right. (After Roonwal and Sen-Sarma, 1960).

with rounded sides; width a little more than length to base of mandibles (length 1.80, width 2.05 mm); Y-suture not clear. Eyes large, subcircular (diameter 0.60 mm); situated very close to antennae. Ocelli oval (max. diameter 0.23 mm); touching eyes. Antennae 13+ segmented; segment 3 subequal to 2 or 4; 5 and 6 subequal. Postclypeus darker than head, with a few bristles anteriorly; anteclypeus subtrapezoidal, whitish, apilose. Labrum subsquarish; almost as wide as long (length 0.55, width 0.65 mm); with a few hairs near anterior margin and on body. Pronotum flat, as wide as head; length 1.30, width 2.15 mm (as measured from figure in Roonwal and Sen-Sarma, 1960 and not 2.5 mm as given by them in measurement table 25, p. 261); anterior margin deeply incurved; sides rounded; posterior margin faintly incurved medially; fairly hairy along margins and on body. Wings not examined but according to Holmgren (1913), radius extending beyond middle of wing, radial sector with 5 branches in distal third and cubitus with 14-15 branches. Apical tibial spurs 3:3:3; tarsi 4-jointed. Abdomen elongate, hairy; cerci 2-jointed.

**SOLDIER** (Fig. 109) : Head-capsule pale to dark brown with reddish tinge; antennae darker basally, paler distally; labrum brownish; mandibles blackish brown, dark reddish brown basally. Head and body sparsely hairy with longish hairs. Total body-length 11.6-11.8 mm. Head subrectangular, elongate (length to base of mandibles 3.66-4.10, max. width 2.20-2.80 mm); wider anteriorly and narrowed posteriorly; frons sloping in front at about 45° angle and with a median depression extending behind up to middle of head dorsum; Y-suture not visible. Eyes translucent, oval (0.20-0.30 mm long); situated at their long diameter from antennae. Antennae with 16 segments; antennal carinae not well developed; segment 3 subequal to or slightly shorter than 2, more chitinised; 4 shortest. Postclypeus darker than frons, with a few hairs anteriorly; anteclypeus whitish, apilose, narrow. Labrum subrectangular to squarish (length 0.38-0.50, width 0.60 mm); anterior margin rounded; with a few long bristles and short hairs near tip and on body. Mandibles short, thick, comparatively thinner than in other species; distally weakly incurved and basally weakly humped at outer margin; length 2.2-2.3 mm. Left mandible with 5 and right with 2, marginal teeth (Fig.109 D,E); margin between 2nd and 3rd marginals of left comparatively longer. Postmentum long, club-shaped; anterior broader portion (club) subequally divided into 2; stalk long, narrow waist; width at waist about half of max. width at club (length 2.60-2.90, max. width 0.75-

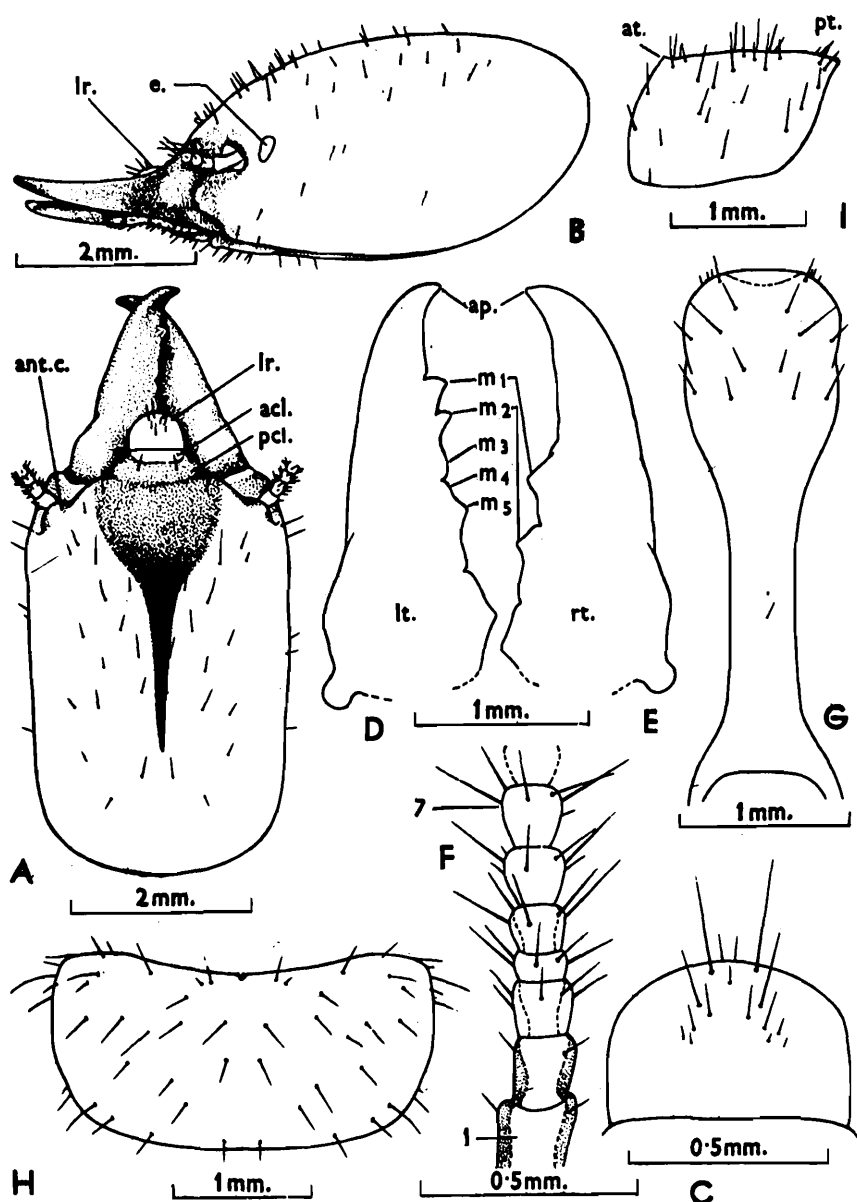

Fig. 109. *Neotermes artocarpi*. Soldier (Cotype). Sarawak, Borneo (Kalimantan). (A) Head, in dorsal view. (B) Same, in side view. (C) Labrum. (D) Left mandible. (E) Right mandible. (F) Basal part of antenna. (G) Postmentum. (H) Pronotum, in dorsal view. (I) Same, in side view.

acl., anteclypeus; ant. c., antennal carina; ap., apices of mandibles; at., anterior; e., eye; lr., labrum; lt., left;  $m_1 - m_5$ , first to fifth marginal teeth of mandibles; pcl., postclypeus; pt., posterior; rt., right. (After Roonwal and Sen-Sarma, 1960).

0.90, width at waist 0.35-0.50 mm). Pronotum flat, subrectangular; almost as wide as head (length 1.10-1.40, width 2.10-2.55 mm); anterior margin weakly incurved; posterior margin substraight; sides rounded. Legs thin and elongate; apical tibial spurs 3:3:3; tarsi 4-jointed. Abdomen elongate, hairy; cerci 2-jointed.

**PSEUDOWORKER** Head pale yellow to pale straw-coloured; antennae, pronotum and legs paler than head; abdomen whitish. Head and body fairly densely hairy. Total body-length 7.20-8.50 mm. Head-capsule subsquarish; almost as wide as its length to base of mandibles (length 1.90-2.0, width 2.0-2.30 mm). Antennae 15-segmented; segment 3 longer than 4 and 5 put together. Postclypeus darker and slightly raised; anteclypeus well developed. Labrum subsquarish, hairy. Mandibles as in genus. Pronotum flat, subrectangular, fairly densely pilose (length 1.10-1.20 mm, width 2.10-2.20 mm); anterior margin deeply incurved; posterior margin subconcave. Legs and abdomen as in soldier.

*Distribution* : BURMA; MALAYSIA (Japore, Sarawak); INDONESIA (Bandar Baroe, Central Sumatra).

*Biology* : It is reported nesting in Jack fruit tree, *Artocarpus integrifolia* Linn., type-host (Haviland and Sharp, 1896), in Sarawak.

#### 14. *Neotermes assmuthi* Holmgren

(Figs. 110-112)

##### 1. *Calotermes/Kalotermes (Neotermes) assmuthi* Holmgren :

1913. Holmgren, *J. Bombay nat. Hist. Soc.*, 22(1): 102-103. Im, S, Pw. Holotype: Not designated; syntypes (Soldiers, alates and pseudoworkers) in Emerson Collection. AMNH, New York. Type-locality: Bangalore (Karnataka, India).

1913. Holmgren, *K. Sv. Vet. Akad. Handl.*, 50(2): 45.

1913. Assmuth, *J. Bombay nat. Hist. Soc.*, 22(2): Explanation of Pl.1.

1934. Margabandhu, *J. Bombay nat. Hist. Soc.*, 37(3): 702.

1953. Rattan Lal and Menon, *Catal. Indian Insects Pt. 27 Isoptera* : 16.

##### 2. *Neotermes assmuthi* Holmgren :

1949. Snyder, *Smiths. misc. Colls.*, 112: 22.

1960. Roonwal and Sen-Sarma, *Contr. Syst. Orient. Termites*, (ICAR, Ent. Monogr. 1): 139, 141, 143, 148-152, 261, 262, 336-339 (Pls. 30, 31). Detailed synonymy, descriptions, etc.

1961. Krishna, *Bull. Am. Mus. nat. Hist.*, 122 (Art. 4): 325.

1975. Sen-Sarma et al., *Wood Destroying Termites. (Final Tech. Rep. PL 480 Project)*: 34, 64.

1975. Chhotani, *Zool. Anz.*, 194(1/2): 117.

1984. Bose, *Occ. Pap. Rec. zool. Surv. India*, No. 49: 15, 22, 23-26, 264.

**IMAGO (Figs. 110, 111) :** Head brown with smoky tinge; remaining parts and body paler than head. Head and body moderately pilose with long hairs. Total length without wings 7.20-8.10 mm. Head-capsule subcircular; width equal to length to base of mandibles (length 1.30-1.45, width 1.50 mm); Y-suture not visible. Eyes subcircular, large (max. diameter 0.5 mm); situated very close to antennae, eye-antennal distance 0.025 mm. Ocelli oval, fairly large (max. diameter 0.20-0.23 mm); touching eyes. Antennae probably 18-segmented (Roonwal & Sen-Sarma, 1960); segment 2 about half of 1, 3 more chitinised and longer than 2 or 4; 5 onwards gradually increasing in length. Postclypeus flat, darker than head; with a few hairs anteriorly. Anteclypeus trapezoidal, whitish, apilose. Labrum subsquarish, length subequal to width (length 0.45, width 0.55 mm); anterior margin rounded; hairy on tip and medially. Pronotum subrectangular, as wide as head and twice its length (length 0.80, width 1.55-1.60 mm); with numerous long hairs; anterior margin weakly incurved; sides rounded; posterior margin

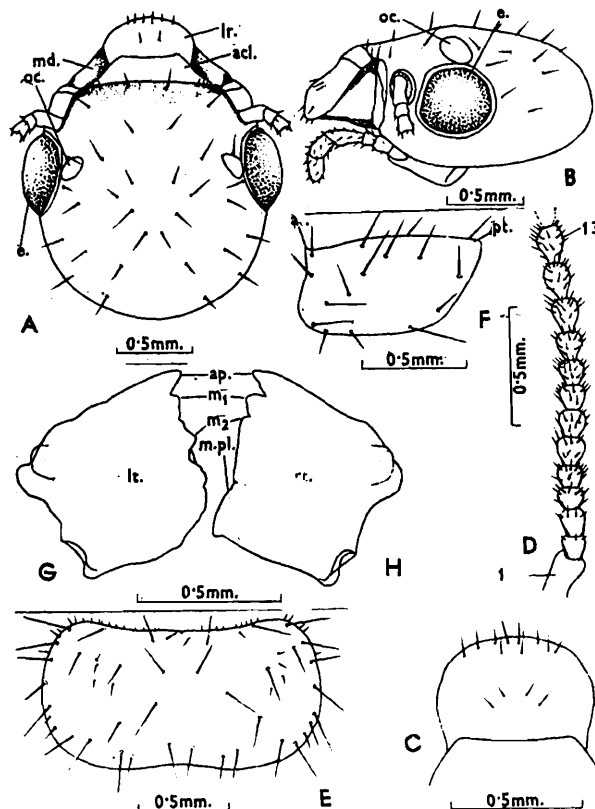

**Fig. 110. *Neotermes assmuthi*. Imago (A-F) and Pseudoworker (G-H). (A) Head, in dorsal view. (B) Same, in side view. (C) Labrum. (D) Right antenna in part. (E) Pronotum, in dorsal view. (F) Same, in side view. (G) Left mandible. (H) Right mandible. Lettering same as in fig. 108. (After Roonwal and Sen-Sarma, 1960).**

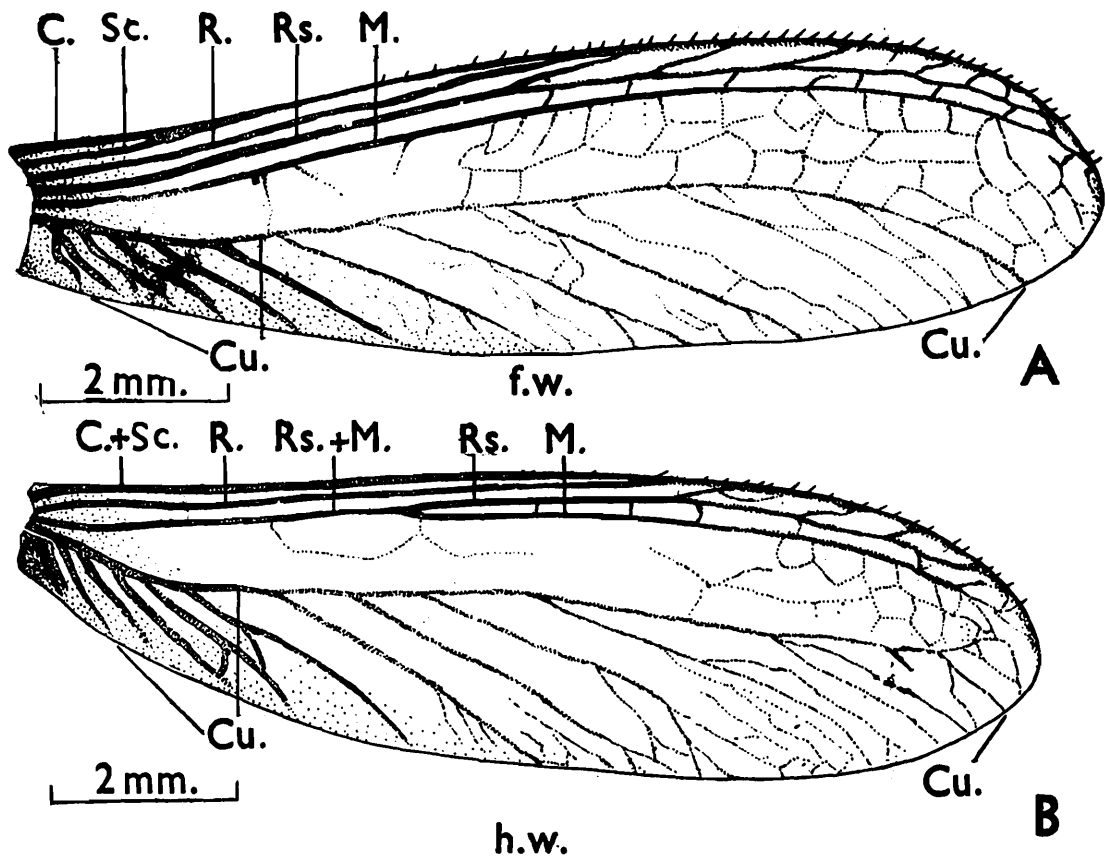

111. *Neotermes assmuthi*. Wings. (A) Right forewing. (B) Right hindwing.

C., costa; C. + Sc., fused costa and subcosta; Cu., cubitus; f.w., forewing; h.w., hindwing; M., Media; R., radius; Rs., radial sector; Rs. + M., fused radial sector and Media; Sc., subcosta. (After Roonwal and Sen Sarma, 1960).

straight with weak median incurving. Legs slender, elongate and hairy; apical tibial spurs 3:3:3; tarsi 4-jointed; empodium present, pale brown. Wings transparent, except for brownish anterior veins and scales. Forewing: 12.1 mm long. Venation as in genus; subcosta extending upto  $1/5$  of wing; radius joining anterior margin at middle; radial sector with 6 branches to anterior margin, first 3 branches prominent; media with 6-7 branches to radial sector; and cubitus with 11-12 branches to posterior margin. Hindwing: Radius extending up to  $2/3$  of wing membrane; radial sector with 3 branches in distal  $1/3$ ; media separating from radial sector just before middle of membrane; and cubitus with 12 branches. Abdomen elongate, moderately hairy; cerci short, 2-segmented.

**SOLDIER** (Fig. 112) : Head-capsule dark brown; antenna and labrum pale brown; mandibles black, basally dark brown; body straw coloured. Head and body fairly hairy. Total body-length 9.5-11.0 mm. Head-capsule

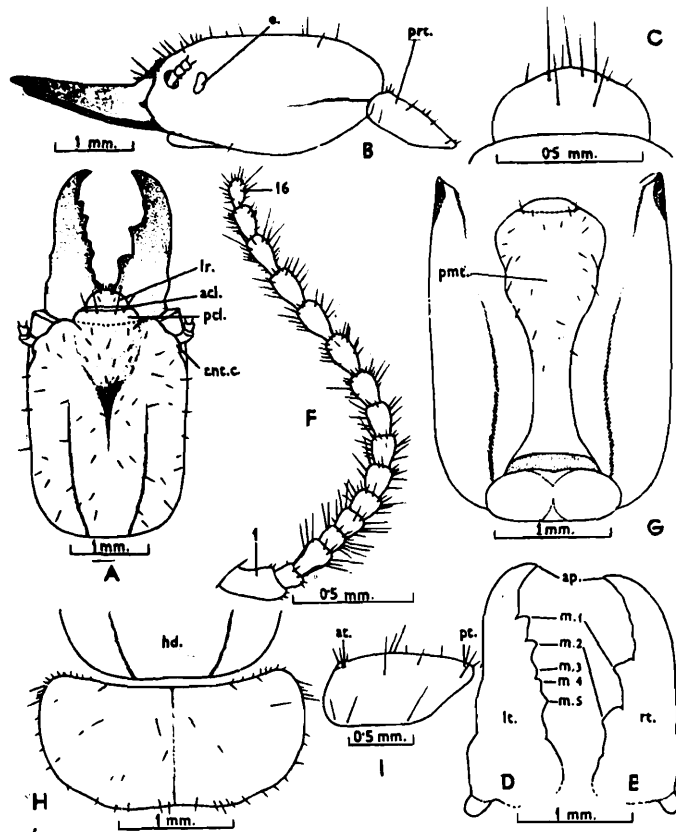

Fig. 112. *Neotermes assmuthi* Soldier. (A) Head, in dorsal view. (B) Head and pronotum, in side view. (C) Labrum. (D) Left mandible. (E) Right mandible. (F) Antenna. (G) Head, in ventral view, showing postmentum. (H) Pronotum, in dorsal view. (I) Pronotum, in side view. Lettering same as in fig. 109 (After Roonwal and Sen-Sarma, 1960).

subrectangular, slightly broader anteriorly; width a little more than  $2/3$ rd of length (length to base of mandibles 2.70-3.40, max. width 2.0-2.23 mm; Width/Length index 0.67-0.74); frons sloping in front at about  $45^\circ$  angle and with a median depression extending behind upto middle of head; Y-suture not visible. Eyes fairly large, oval; situated at about their long diameter from antennae; 0.23-0.35 mm long. Ocelli absent. Antennae with 16 segments; antennal carinae well developed; segment 3 darker and longer than 2; 4 equal to 2. Postclypeus short, flat, darker in colour; with a pair of hairs anteriorly on either side. Anteclypeus thin, apilose, hyaline, strip-like. Labrum short semicircular; with a few hairs anteriorly near tip and on disc. Mandibles thick, stout, weakly humped at outer margin;  $2/3$ rd of head-length or a little less (length 1.80-1.95 mm; Mandibles/Head length index 0.61-0.66). Left mandible with 5 marginal teeth and right with 2 large marginals (Fig. 112 D,E) Postmentum long, club-shaped; anterior part (club) bilobed; anterior lobe broader than posterior lobe; waist narrow, less than half of max. width (length 1.9-2.3, max. width 0.75-0.78, width at waist

0.30 mm). Pronotum subrectangular (length 0.98-1.08, width 1.93-2.20 mm); almost as wide as head; anterior margin slightly incurved, not notched; posterior margin substraight with weak incurving; sides rounded. Legs moderately long, hairy; apical tibial spurs 3:3:3. Abdomen elongate, hairy; cerci 2-jointed.

**PSEUDOWORKER** : Head-capsule straw coloured; labrum paler; antennae, pronotum, legs and body yellowish. Head and body moderately hairy. Total body-length 6.5-7.0 mm. Head-capsule subsquarish, a little wider than its length to base of mandibles (length 1.5-1.6, width 1.8-1.9 mm). Antennae with 15 segments; segment 3 subequal to or shorter than 2; 4 subequal to 5. Postclypeus dark and pilose; anteclypeus well developed. Labrum subsquarish. Mandibles as in genus. Pronotum subrectangular, narrower than head (length 0.80-0.90, width 1.50-1.60 mm); anterior margin fairly deeply incurved; posterior margin convex. Legs and abdomen as in soldier.

*Distribution* : INDIA Karnataka : Bangalore (type-locality), Shanbhoghahalli, Meghalpura and Tallagatpura. Goa.

*Biology* : It attacks *Artocarpus heterophyllus*, *Mangifera indica* (mango), 'Basri' and 'Banyan' trees. The nest is in the form of long, narrow galleries in dead portions of trees extending slowly to the adjacent live tissue also. The galleries are irregular and filled with damp faecal pellets lumped in small masses.

### 15. *Neotermes bosei* Snyder

[Syn. *Kalotermes (Neotermes) gardneri* Snyder]

(Figs. 113-116)

#### 1. *Kalotermes (Neotermes) bosei* Snyder :

1933. Snyder, *Proc. U.S. natn. Mus.*, 82(16): 2-3. S, Ny. Holotype: S, in BM, London. Type-locality: Mathranwala, about 12 km South of Dehra Dun, Uttar Pradesh, India.

1934. Snyder, *Indian For. Rec.*, 29(11): 2-3. Wrong determination.

1935. Margabandhu, *J. Bombay nat. Hist. Soc.*, 38(1): 208-209.

1953. Rattan Lal and Menon, *Catal. Indian Insects Pt. 27 Isoptera* : 16 (Part, specimens from Mathranwala only are *bosei*).

2. *Neotermes bosei* Snyder :

1949. Snyder, *Smiths. misc. Colls.*, 112: 22 (Part, specimens from Mathranwala only are *bosei*).
1953. Roonwal and Pant, *Indian For. Leaf. (Ent.)*, No. 121(3): 49. (Part, specimens from Mathranwala only are *bosei*).
1960. Roonwal and Sen-Sarma, *Contrib. Syst. Orient. Termites* (ICAR Ent. Monogr. 1): 139, 141, 143, 152-161, 261, 262, 340-343 (Pls. 33, 34).
1965. Sen-Sarma and Chatterjee, *Indian Forester*, 91: 805-813.
1967. Roonwal and Chhotani, *J. Bombay nat. Hist. Soc.*, 63(2): 356, 362.
1975. Chhotani, *Zool. Anz.*, 194(1/2): 113, 117.
1975. Sen-Sarma et al., *Wood Destroying Termites (Final Tech. Rep. PL. 480 Project)*: 34-35, 64, 72.
1977. Roonwal and Chhotani, *Ent. Basil.*, 2: 44-45.
1980. Chhotani, *Tech. Monogr. Zool. Surv. India*, No. 4: 4, 13, 14.
1980. Sen-Sarma and Thakur, *Indian For. Rec. (N.S.) Ent.*, 14 (1): 2-3.
1983. Maiti, *Occ. Pap. Rec. zool. Surv. India*, No. 42: 15-16, 22, 27-30.

3. *Kalotermes/Calotermes (Neotermes) gardneri* Snyder :

1933. Snyder, *Proc. U.S. natn. Mus.*, 82(16): 3-4. Imago. Holotype not designated. Syntypes in FRI, Dehra Dun; BM, London; U.S. National Museum, Washington and AMNH, New York. Type-locality : Dehra Dun (U.P., India).
1935. Margabandhu, *J. Bombay nat. Hist. Soc.*, 38(1): 208-209.
1953. Rattan Lal and Menon, *Cat. Indian Insects Pt. 27 Isoptera*: 16.

4. *Neotermes gardneri* Snyder :

1949. Snyder, *Smiths. misc. Colls.*, 112: 25.
1953. Roonwal and Pant, *Indian For. Leaf. (Ent.)*, No. 121(3): 49.
1955. Roonwal and Sen-Sarma, *J. Bombay nat. Hist. Soc.*, 53(2): 234-239.
1960. Roonwal and Sen-Sarma, *Contrib. Syst. Orient. Termites*. (ICAR Ent. Monogr. 1): 139, 153, 160, 161.
1961. Krishna, *Bull. Am. Mus. nat. Hist.*, 122 (Art. 4): 325.
1975. Chhotani, *Zool. Anz.*, 194 (1/2): 113, 117.

IMAGO (Figs. 113, 114) : Head-capsule castaneous brown; pronotum brownish; antennae and legs yellowish. Head and body sparsely hairy. Total body-length with wings 15.5-19.7, without wings 8.5-10.5 mm. Head-capsule subsquarish, length to base of mandibles less than width with eyes

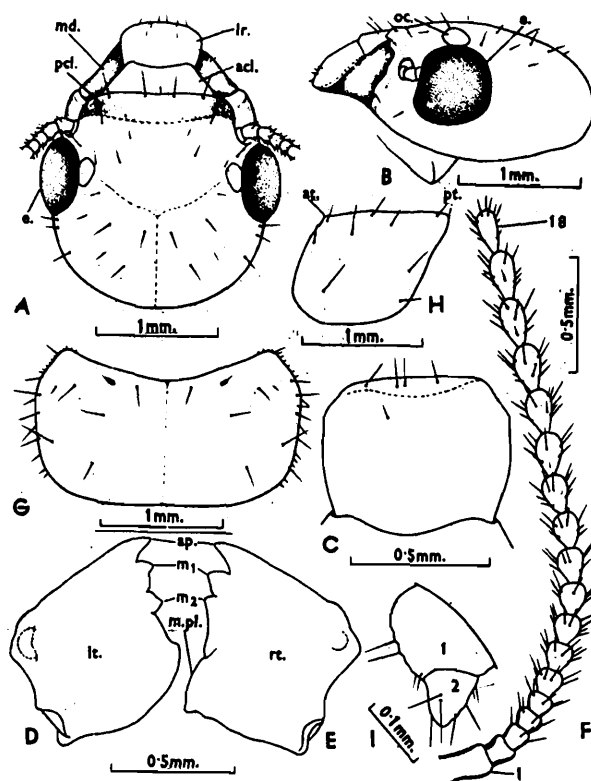

Fig. 113. *Neotermes bosei*. Imago. (A) Head, in dorsal view. (B) Same, in side view. (C) Labrum. (D) Left mandible. (E) Right mandible. (F) Right Antenna. (G) Pronotum, in dorsal view. (H) Same, in side view. (I) Cercus (left). Lettering same as in fig. 108. (After Roonwal and Sen-Sarma, 1960).

(length 1.50-1.90, width 1.90-2.03 mm); Y-suture distinct; posterior margin rounded; sides without eyes substraight. Eyes large, black, subcircular; straight at anterior margin (0.65 mm in max. diameter). Ocelli broadly oval (length 0.20); touching eyes. Antennae with 17 to 18 segments; segment 2 generally longer, sometimes as long as 3; 3 slightly longer than 4; 5 onwards gradually increasing in length. Postclypeus flat, darker than head, with 2 pairs of longish hairs anteriorly; anteclypeus trapezoidal, whitish, longer than postclypeus. Labrum subsquarish, broader than long (length 0.30-0.35, width 0.50-0.65 mm). Mandibles as in genus. Pronotum flat, subrectangular; a little longer than half of width and as wide as head (length 1.10-1.20, width 1.90-2.16 mm); anterior margin strongly concave; sides rounded; posterior margin substraight. Legs long and slender; tibial spurs 3:3:3; tarsi 4-jointed; empodium present, brownish. Wings transparent, not

tuberculate. Forewing: 13.0-16.0 mm long. Venation as in genus; subcosta meeting costa at 1/4th of length or sometimes even shorter; radius extending up to half of wing or a little shorter; radial sector with 7-8 branches to costal

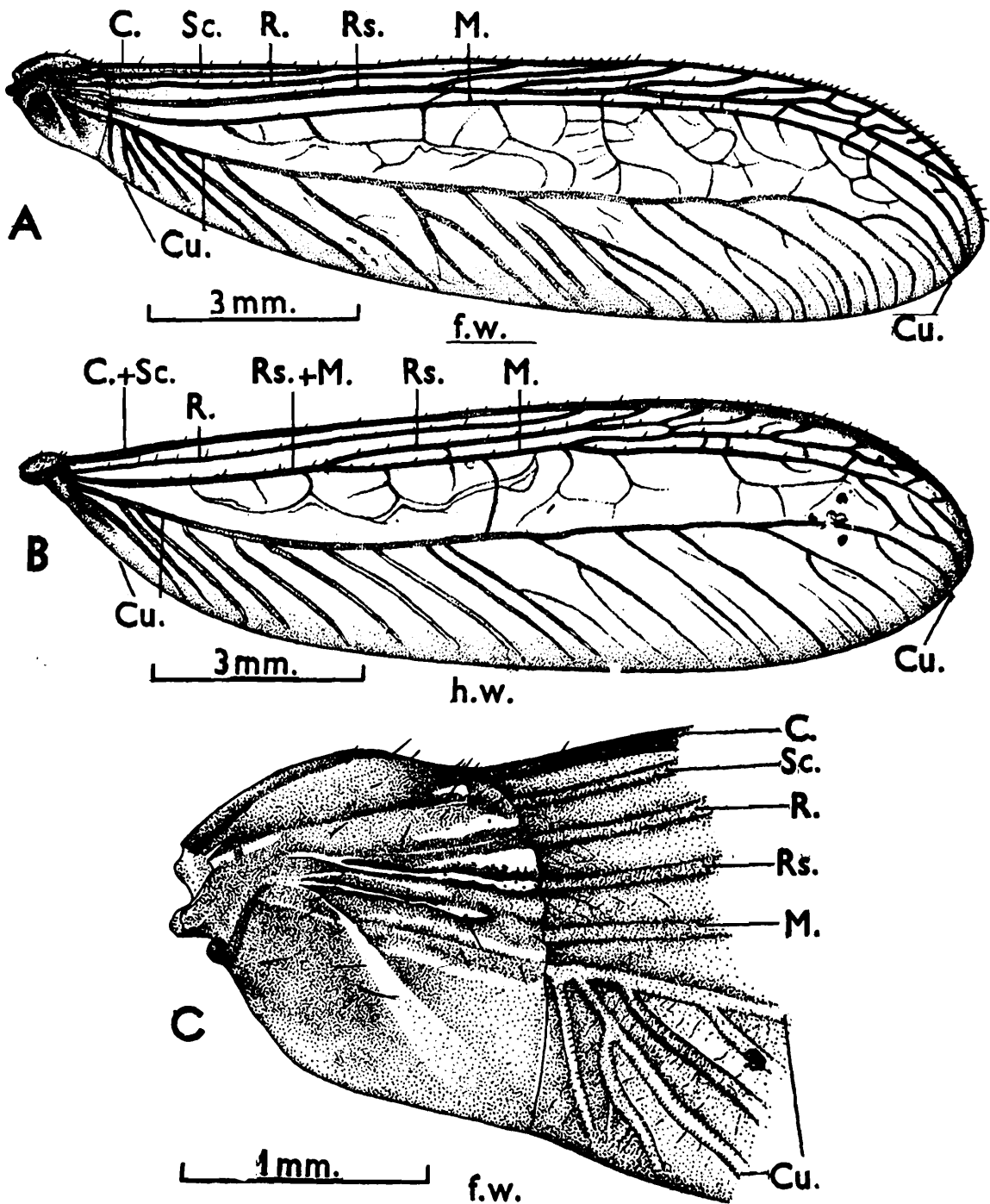

Fig. 114. *Neotermes bosei* Wings. (A) Right forewing. (B) Right hindwing. (C) Right forewing; proximal part including scale, enlarged, to show origin of different veins from scale. Lettering same as in fig. 111. (After Roonwal and Sen-Sarma, 1960).

margin; media with 7-8 branches to radial sector; cubitus with 14-15 branches, distally with ramification. Hindwing: 11.9-15.2 mm long. Radius meeting costa-subcosta at 2/3rd of length of wing; radial sector with 5-6 branches; media arising from radial sector at 1/3rd of wing; cubitus with about 14 branches. Abdomen elongate; hairy; cerci 2-jointed, hairy.

**SOLDIER** (Figs. 115, 116) Head-capsule castaneous brown with reddish tinge, sometimes a little paler; antennae pale brown distally, darker proximally; labrum pale brown; mandibles black, dark brown basally; body and legs straw coloured. Head and body sparsely hairy. Total body-length 9.5-12.00 mm. Head-capsule subrectangular (length 2.9-4.0, width 2.22-2.52 mm; index Width/Length 0.59-0.83); frons sloping in front, with median depression extending behind upto occiput; Y-suture indistinct or not visible. Eyes whitish, oval, 0.20-0.30 mm long; situated at about their length from antennae. Ocelli absent. Antennae 14 to 16- (mostly 14-15) segmented; carinae weak; segment 3 darker, either longer or subequal to 2; onwards segments gradually increasing in length. Postclypeus darker, subrectangular, with 2 pairs of long hairs anteriorly; anteclypeus apilose, trapezoidal, hyaline. Labrum subsquarish to subrectangular (0.24-0.50 mm long and 0.42-0.66 mm wide); with a few hairs anteriorly and on body. Mandibles stout and strong; basally humped at outer margin; length 1.7-2.10 mm, subequal to half to about 2/3rd of head-length (index Mandible-length/Head length 0.46-0.62). Left mandible generally with 5 marginals, sometimes marginals not well marked. Right with 2 large marginals. Postmentum long, club-shaped; club either not or very faintly bilobed; length 2.2-3.0, max. width at club 0.75-0.84, width at waist 0.25-0.36 mm; waist long and narrow. Pronotum flat, subrectangular; a little narrower to as wide as head (length 0.90-1.26, width 2.04-2.50 mm; Pronotum-width/Head-width index 0.84-1.04); anterior margin broadly concave, not notched; sides rounded; posterior margin substraight, not notched. Legs long and slender; apical tibial spurs 3:3:3; tarsi 4-jointed. Abdomen elongate; cerci 2-jointed.

**PSEUDOWORKER** : Head-capsule pale straw-coloured; antennae, legs and body whitish with yellowish tinge; labrum brownish. Head and body moderately hairy. Total body-length 7.0-9.0 mm. Head-capsule subcircular (length to base of mandibles 1.4-1.80, width 1.50-2.0 mm); Y-suture not

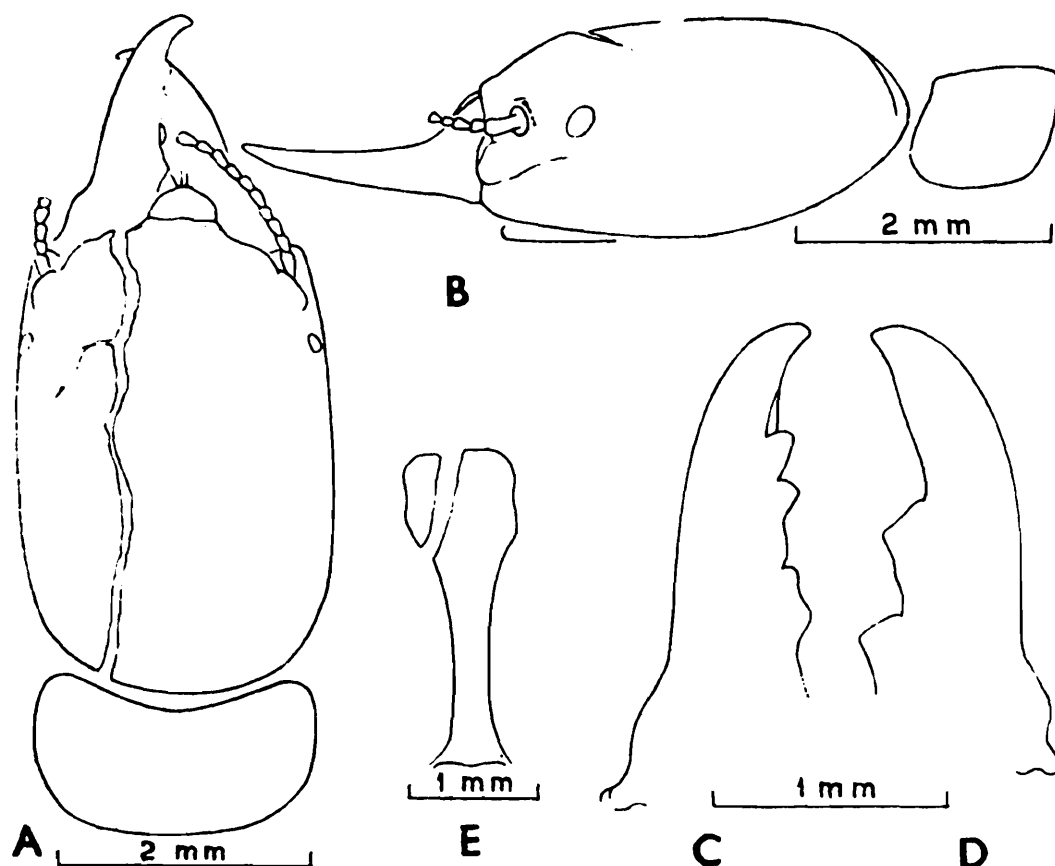

Fig. 115. *Neotermes bosei*. Soldier (Holotype). Specimen slightly damaged. (A) Head and pronotum, in dorsal view. (B) Same, in side view. (C) Left mandible. (D) Right mandible. (E) Postmentum (After Roonwal and Sen-Sarma, 1960).

visible. Eyes and ocelli absent. Antennae with 15 segments; segments 2 and 3, and 4 and 5, subequal. Postclypeus flat, rectangular, pilose, darker than frons; anteclypeus trapezoidal, apilose. Mandibles as in genus. Pronotum subrectangular, as wide as head (length 0.70-1.20, width 1.50-2.0 mm); anterior margin concave; posterior margin subconvex. Legs and abdomen as in soldier.

**Distribution :** INDIA : Uttar Pradesh : Dehra Dun and Mathranwala, Dehra Dun; Bageswar, Kumaon Hills. West Bengal : Samsing, Bagdogra, Cooch Behar For. Range and Chalsa For. Range (Jalpaiguri Dist.). Also Bhutan (Phuntsholing, Samchi).

**Biology :** This species lives in semi-wild state and is quite common in Doon Valley. It is recorded from several trees such as *Acer oblongum*, *Artocarpus heterophyllus*, *A. lakoocha*, *Ficus* spp., *Mangifera indica*, *Pterospermum aceripholium* and *Toona ciliata*. Its nest is in the form of irregular, large (c 30 × 2.4 mm), interconnected galleries running along the

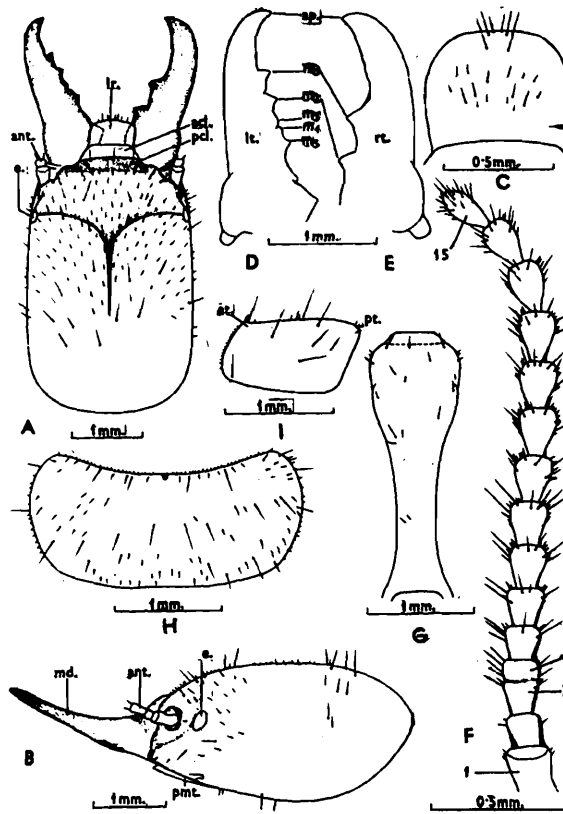

Fig. 116. *Neotermes bosei*. Soldier. (A) Head, in dorsal view. (B) Same, in side view. (C) Labrum. (D) Left mandible. (E) Right mandible. (F) Antenna. (G) Postmentum, in ventral view. (H) pronotum, in dorsal view. (I) Same, in side view. Lettering Same as in fig. 109. (After Roonwal and Sen-Sarma, 1960).

fibre of the plant and penetrating deep into the heartwood. The galleries are filled with brownish faecal pellets which being hygroscopic probably help in maintaining the required level of humidity in the nest. Swarming has been recorded from February to July (Roonwal and Sen-Sarma 1955; Sen-Sarma et al. 1975).

## 16. *Neotermes buxensis* Roonwal and Sen-Sarma (Figs. 117-119)

### 1. *Neotermes buxensis* Roonwal and Sen-Sarma :

1960. Roonwal and Sen-Sarma, *Contrib. Syst. Oriental Termites* (ICAR Ent. Monogr. 1): 139, 140, 143, 161-166, 263, 264, 344-347 (Pls. 34, 35). Im, S, Pw. Holotype : S, in FRI, Dehra Dun. Type-locality: Buxa Forest Division, West Bengal, India. Type examined.

1975. Chhotani, *Zool. Anz.*, 194 (1/2): 117.

1975. Sen-Sarma et al., *Wood Destroying Termites (Final Tech. Rep. PL 480 Project)*: 35, 64.

1983. Maiti, *Occ. Pap. Rec. zool. Surv. India*, No. 42: 4, 16, 21, 30-31, 132, 141.

2. *Neotermes bosei* Snyder (Wrong determinations):

1934. Snyder, *Indian For. Rec.*, 20(11): 2-3. Im, S. Specimens from Buxa Forest Division, West Bengal are *buxensis*.

1949. Snyder, *Smiths. misc. Colls.*, 112: 22. Specimens from Buxa Forest Division only are *buxensis*, others are *bosei* Snyder.

1953. Roonwal and Pant, *Indian For. Leaflet (Ent.)*, No. 121(3): 49. Specimens from Buxa only are *buxensis*, others are *bosei* Snyder.

1953. Rattan Lal and Menon, *Catal. Indian Insects Pt. 27, Isoptera* : 16. Specimens from Buxa only are *buxensis*, others are *bosei* Snyder.

**IMAGO (Figs. 117, 118) :** Head-capsule pale castaneous brown; pronotum and abdomen above somewhat paler than head; antennae, labrum, legs and abdominal sternites pale yellow. Head and body moderately hairy. Total body-length with wings 16.3, without wings 7.0-9.0 mm. Head-capsule subsquarish, sides slightly narrowed and rounded behind eyes; with eyes almost as wide as its length to base of mandibles (length 1.9, width 1.9 mm); Y-suture prominent. Eyes large, subcircular,

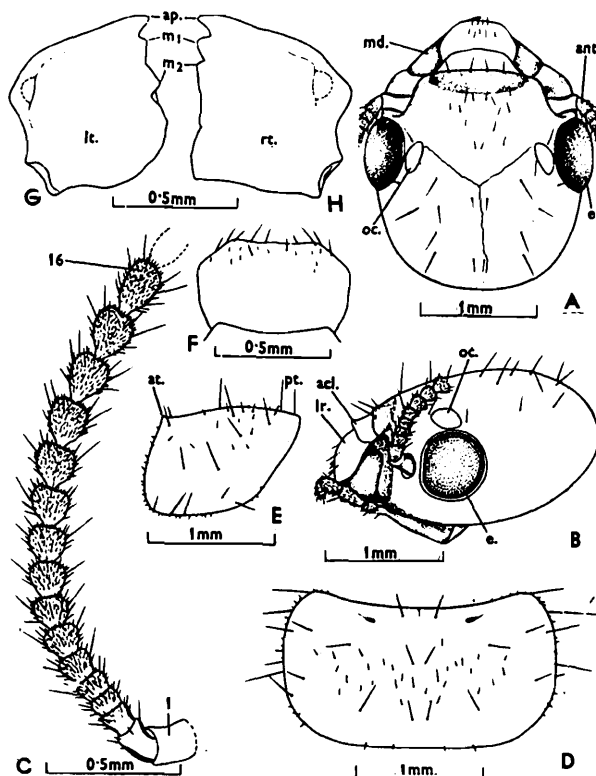

**Fig. 117. *Neotermes buxensis*.** Imago (A-E) and Pseudoworker (F-H). (A) Head, in dorsal view. (B) Same, in side view. (C) Left antenna, distal segments broken. (D) Pronotum, in dorsal view. (E) Same, in side view. (F) Labrum. (G) Left mandible. (H) Right mandible. Lettering same as in fig. 108. (After Roonwal and Sen-Sarma, 1960).

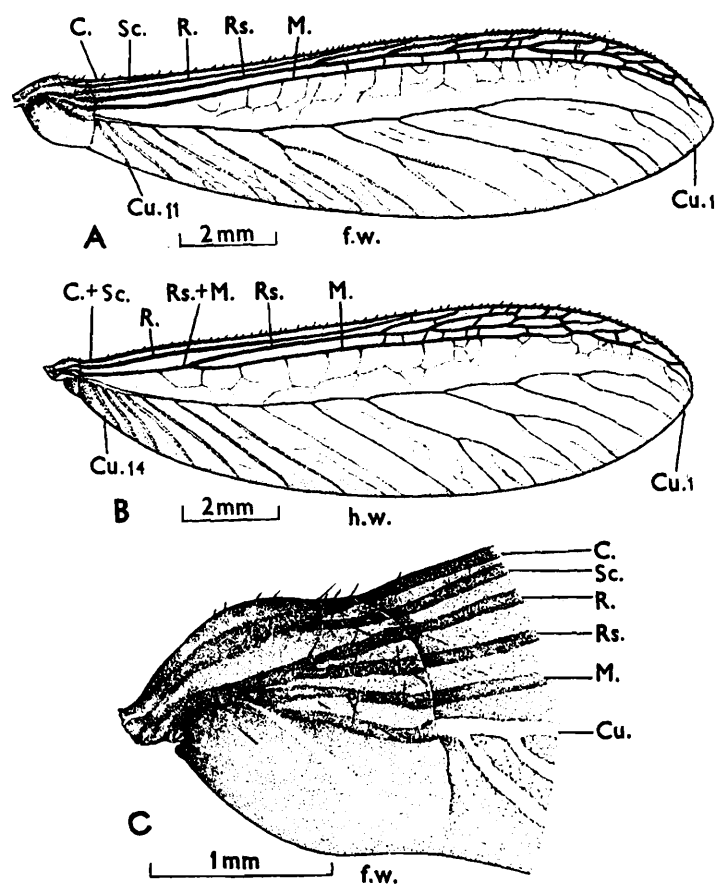

Fig. 118. *Neotermes buxensis*. Wings. (A) Right forewing. (B) Right Hindwing. (C) Right forewing; proximal part including scale, enlarged. Lettering same as in fig. 111 (After Roonwal and Sen-Sarma, 1960).

0.60-0.65 mm in diameter; situated very close to antennae, eye-antennal distance 0.023-0.038 mm. Ocelli oval, translucent; faintly separated from eyes, almost touching (long diameter 0.23, eye-ocellus distance 0.0125 mm).

Antennae with 16+ segments; segment 2 longer than 3; 3 and 4 subequal and 5 onwards gradually increasing in length. Postclypeus subrectangular, darker than frons and with a pair of hairs anteriorly on either side of middle; anteclypeus trapezoidal, apilose, hairy. Labrum subsquarish, round at sides and substraight anteriorly; length 0.50, width 0.60 mm; hairy anteriorly and on body. Pronotum subrectangular; a little wider than head and twice its length (length 1.10, width 2.2 mm); anterior margin weakly incurved, sides rounded, posterior margin substraight; both anterior and posterior margins without median notch; fairly hairy with long and short hairs on margins and on body. Legs slender, hairy, apical tibial spurs 3:3:3; tarsi 4-segmented; empodium yellowish. Wings transparent, non-tuberculate, without hairs.

Forewing: 14.90 mm long. Venation in general as in genus; subcosta meeting costa at 1/4th of wing; radius meeting costa-subcosta almost at middle; radial sector with 5 to 7 branches to costa-subcosta; media with about 12 transverse veins to radial sector; area between media and cubitus reticulate; cubitus with 10 branches to posterior margin. Hindwing: 13.0 mm long. Radius meeting costa-subcosta a little beyond middle; radial sector with 6 branches to costa-subcosta; media originating from radial sector at proximal 1/5th of wing; cubitus with 14 branches. Abdomen elongate hairy; cerci 2-jointed.

**SOLDIER** (Fig. 119): Head-capsule pale brown to brown; antennae brownish basally, paler distally; mandibles blackish, dark brown with reddish tinge at base; legs and body yellowish white. Head and body sparsely hairy. Total body-length 10.5-13.2 mm. Head-capsule subrectangular, widest at base of antennae and slightly narrowing behind (length to base of mandibles 3.69-4.30, width 2.40-2.52 mm); frons sloping in front at about 45°, with a median depression extending behind upto middle of head; Y-suture not visible. Eyes whitish, translucent, oval, 0.30-0.33 mm long, and separated from antennae by about their length. Ocelli absent. Antennae with 14-15 segments; carinae weak; segment 3 subequal to 2; 4 shorter; onwards gradually increasing in length, last slightly shorter than penultimate. Postclypeus subrectangular, with 2 pairs of hairs at anterior margin; anteclypeus subtrapezoidal, whitish, apilose; labrum small, subrectangular, anteriorly rounded (length 0.54, width 0.66-0.78 mm); hairy near anterior margin. Mandibles short and robust; almost half of head-length to base of mandibles (length 1.9-2.07 mm, Mandible-length/Head-length index 0.48-0.53); basally strongly humped at outer margin. Left mandible with 5 marginal teeth, right with 2 large ones in basal half (Fig. 119 D,E). Postmentum long, club-shaped; club strongly bilobed; waist long and narrow; median length 2.90-3.06, maximum width 0.9, width at waist 0.3-0.42 mm. Pronotum subrectangular, length more than half of width and almost as wide as or a little wider than head (length 1.3-1.53, width 2.5-2.79 mm); antero-lateral angles sharply rounded; sides weakly convex and slightly narrowing behind; anterior margin strongly incurved, not notched; posterior margin substraight. Legs short and slender; apical tibial spurs 3:3:3; tarsi 4-segmented. Abdomen elongate; hairy, with a row of hairs on each tergum; cerci 2-jointed; short.

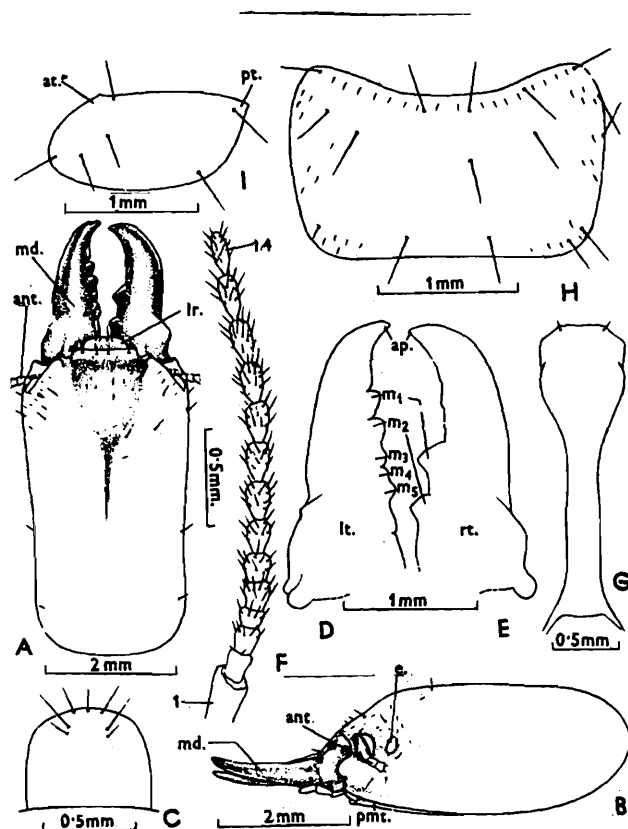

Fig. 119. *Neotermes buxensis*. Soldier. All figures from holotype except (C) and (F). (A) Head, in dorsal view. (B) Same, in side view. (C) Labrum. (D) Left mandible. (E) Right mandible. (F) Left Antenna. (G) Postmentum, in ventral view. (H) Pronotum, in dorsal view. (I) Same, in side view. Lettering same as in fig. 109. (After Roonwal and Sen-Sarma, 1960).

**PSEUDOWORKER** : Head pale straw-coloured; labrum, antennae and body creamish. Head and body moderately hairy. Total body-length 8.5 mm. Head-capsule subsquarish (length to base of mandibles 1.9, width 2.0 mm). Eyes rudimentary, small, whitish, visible only in strong light. Antennae 15-segmented; segment 3 shorter than 2; 3, 4, 5 subequal, shortest. Postclypeus subrectangular, darker than head and with 2 pairs of hairs on anterior margin; anteclypeus trapezoidal, apilose. Labrum subrectangular, anteriorly substraight; hairy at anterior margin and body. Mandibles as in genus. Pronotum subrectangular, wider than head (length 1.2, width 2.4 mm); anterior margin concave; posterior margin substraight. Legs and abdomen as in soldier.

**Distribution** : INDIA : West Bengal; Buxa Forest Division, (Type-locality) Bagdogra.

17. *Neotermes dhirendrai* Bose  
(Figs. 120, 121)

1984. *Neotermes dhirendrai* Bose, *Occ. Pap. Rec. zool. Surv. India*, No. 49: 15, 23, 26-30, 254, 264. S, Pw. Holotype : S, in ZSI, Calcutta. Type-locality: India : Salem (Tamil Nadu). Type examined.

IMAGO : Unknown.

**SOLDIER** (Fig. 120) : Head-capsule reddish brown, paler posteriorly; postclypeus and labrum slightly darker; anteclypeus hyaline; mandibles chestnut brown, basally bright reddish brown; antennae pale golden brown, segment 3 dark, strongly sclerotised; thorax, legs and body creamy yellow. Head and body sparsely hairy. Total body-length 11.3 mm. Head-capsule subrectangular, length one-and-a-half times of width (length to base of mandibles 3.30, width 2.20 mm); sides rounded to a substraight and faintly incurved posterior margin; Y-suture prominent; frons sloping in front at about 45° angle. Eyes translucent, large (0.30 mm long); situated behind antennae at about half their long diameter (0.20 mm). Ocelli small, whitish, spot-like; situated at end of lateral arms of Y-suture. Postclypeus flat, subrectangular, faintly separated from frons; with a pair of short hairs on either side. Anteclypeus apilose, hyaline, strip-like. Labrum short, broad; apically rounded; with short and long bristles on anterior margin and body. Antennae with 13+ segments; segment 3 strongly sclerotised and about one-and-a-half times as long as 2; 4 and 5 subequal, shorter than 2; 6-11 gradually increasing in size; 12 and 13 slenderer than preceding ones. Mandibles short, thick (length 1.80 mm); weakly incurved apically; slightly longer than half of head-length to base of mandibles (index Mandible-length/Head-length 0.54); moderately humped in basal third at outer margin. Left mandible with 7 and right with 2 marginal teeth (as in Fig. 120 A). Postmentum long, club-shaped; club bilobed, anterior lobe a little narrower than posterior one; waist long and narrow, width at waist about 1/3rd of maximum width (length 2.55, max. width at posterior lobe 0.88, width at waist 0.30 mm). Pronotum flat, a little wider than head-capsule and much broader than long (length 1.30, max. width 2.28 mm); with a few long and short bristles on margins and body; anterior margin shallowly incurved; sides weakly rounded; posterior margin substraight, with a faint median incurving. Meso- and metanota semicircular, with substraight sides;

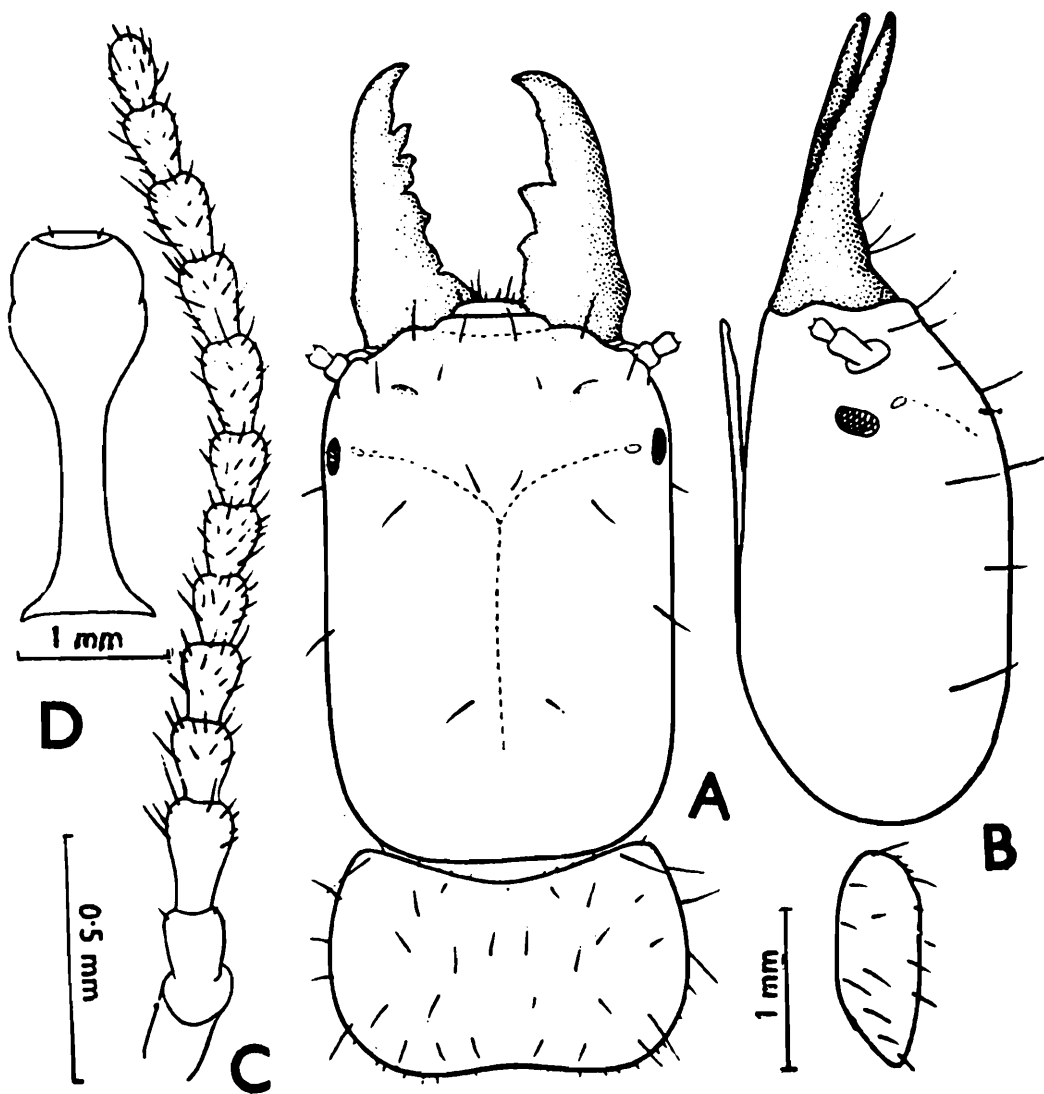

Fig. 120. *Neotermes dhirendrai* Soldier. (A) Head and pronotum in dorsal view. (B) Same, in side view. (C) Antenna. (D) Postmentum. (After Bose, 1984).

**PSEUDOWORKER** (Fig. 121) : Head-capsule pale creamish yellow; antennae, legs and body pale creamy whitish; clypeus and labrum pale brownish; mandibles pale brownish with blackish brown toothed region. Head and body fairly densely hairy. Total body-length 8.40 mm. Head-capsule subcircular; a little broader than long (length to base of mandibles 1.73, max. width 1.88 mm). Eyes large, oval, 0.23 mm long. Antennae with 16 segments, 4 shortest. Postclypeus flat, with 2-3 bristles on either side; anteclypeus narrow, apilose, flat. Labrum broad, tongue-shaped; with several long and short hairs on body. Mandibles as in genus. Pronotum flat; broader than long (length 1.03, max. width 2.03 mm); anterior margin weakly concave; posterior margin slightly convexical. Legs short and hairy;

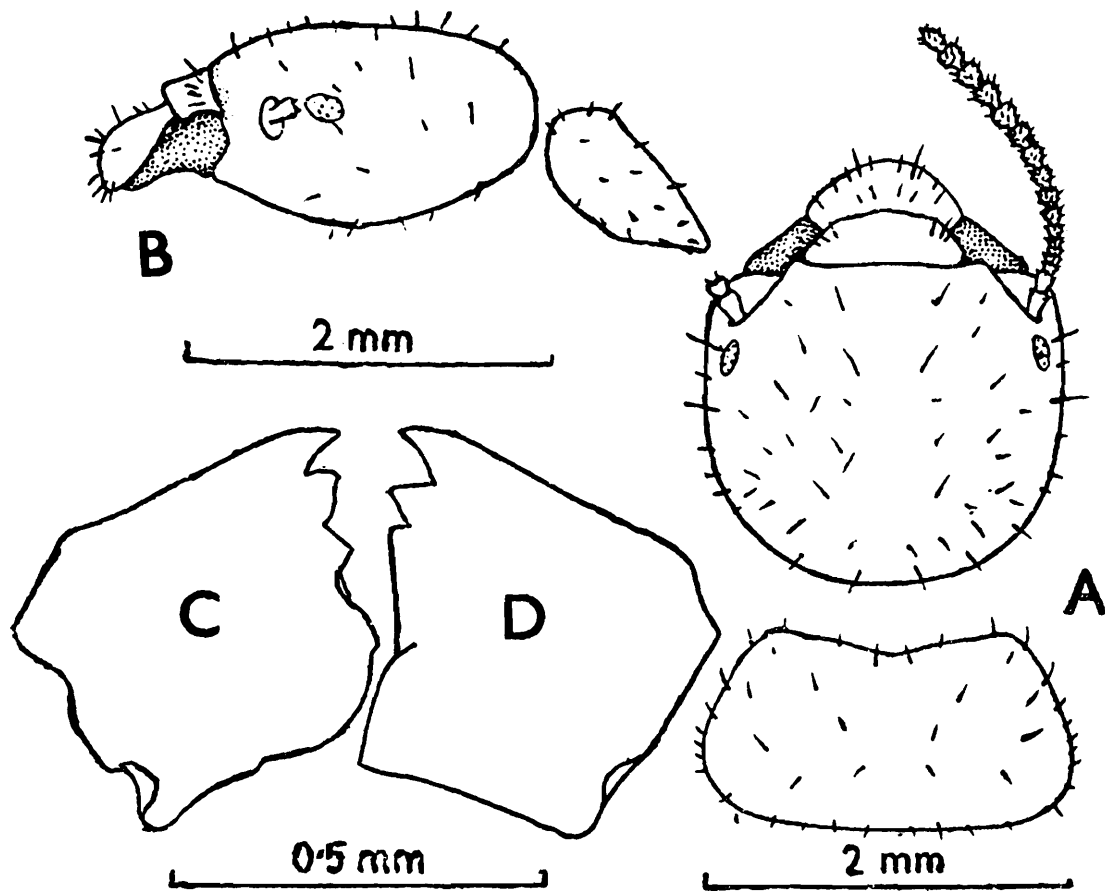

Fig. 121. *Neotermes dhirendrai*. Pseudoworker. (A) Head and pronotum in dorsal view. (B) Same, in side view. (C) and (D) Left and right mandibles. (After Bose, 1984).

apical tibial spurs 3:3:3; tarsi 4-jointed. Abdomen oblong, creamish in colour; cerci 2-jointed, 0.15 mm long; styli single-jointed, 0.19 mm long.

*Distribution* : INDIA : Tamil Nadu : Salem (type-locality), known only from type-locality.

*Biology* : It is reported making narrow, irregular galleries in dead portion of a mango tree at Salem (Tamil Nadu, South India).

### 18. *Neotermes eleanorae* Bose

(Figs. 122, 123)

1984. *Neotermes eleanorae* Bose, *Occ. Pap. Rec. zool. Surv. India*, No. 49: 15, 22, 30-37, 254, 264. Im, S, Pw. Holotype : S, In ZSI, Calcutta. Type-locality : Mangalore (Karnataka, India). Type examined.

IMAGO (Fig. 122) : Head-capsule reddish brown; clypeus, labrum and antennae golden brown; mandibles dark reddish brown apically, paler

posteriorly; thorax and body dull golden brown; legs yellowish; wings brownish hyaline. Head and body fairly and legs sparsely, hairy. Total body-length with wings 14.40-16.60, without wings 7.60-9.40 mm. Head-capsule subsquarishly oval, a little broader than its length to base of mandibles (length 1.45-1.65, width with eyes 1.60-1.70 mm); sides subparallel rounded at postero-lateral angles; Y-suture distinct. Eyes large, oval; shorter than pronotum. Legs short, stout and sparsely hairy; apical tibial spurs 3:3:3; tarsi 4-jointed. Abdomen oblong, hairy; cerci 2-jointed, 0.15 mm long.

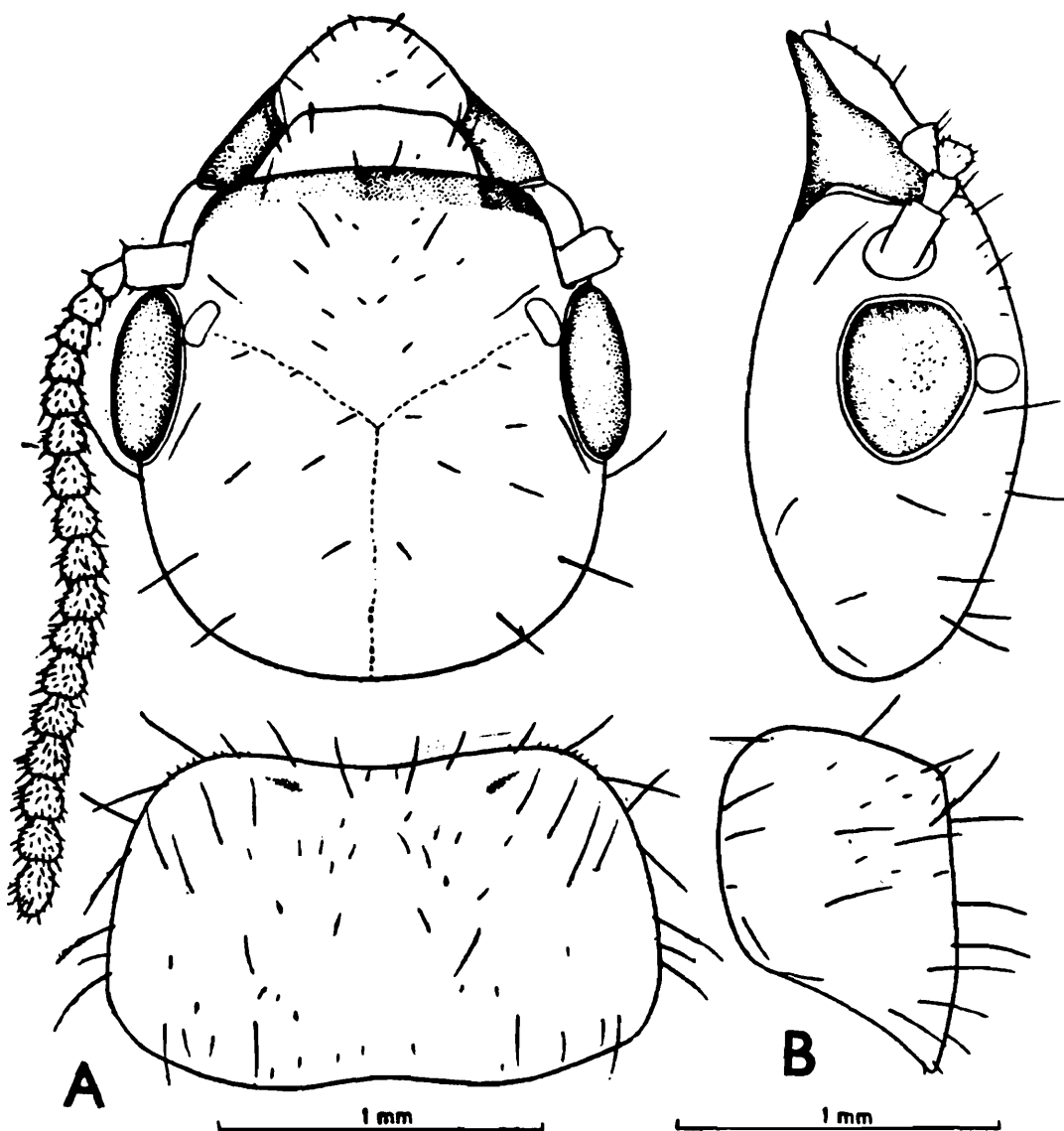

Fig. 122. *Neotermes eleanorae*. Imago (Paramorphotype). (A) Head and pronotum, in dorsal view. (B) Same, in side view. (After Bose, 1984).

anteriorly substraight (max. diameter 0.55-0.60, min. diameter 0.45-0.50 mm). Ocelli broadly oval (max. diameter 0.20-0.28, min. diameter 0.18-0.20 mm); touching eyes. Antennae 18-segmented; segment 3 shorter than 2; 4 shortest. Postclypeus trapezoidal; with a pair of long and one short bristles on either side. Anteclypeus hyaline, apilose, short, strip-like. Labrum broadly dome-shaped; with a few long and short hairs on anterior margin and on body. Mandibles as in genus. Pronotum flat, subrectangular, wider posteriorly; wider than head with eyes; length about 2/3rd of width (length 1.00-1.10, width 1.58-1.88 mm); with short and long hairs on margins and body. Legs long and hairy; tibial spurs 3:3:3; tarsi 4-jointed; empodium present. Wings pale brown, transparent; membrane without tubercles. Forewing : Length 11.40-13.50 mm. Venation as in genus; subcosta meeting costa at a little distance from scale; radius meeting costa-subcosta a little beyond middle; radial sector with 5-6 branches to costal border; media giving 5-6 branches to radial sector in distal half; cubitus with 9-10 branches to posterior margin. Hindwing : Length 10.30-11.70 mm. Scale small. Venation as in genus; radius meeting costa-subcosta beyond middle; radial sector with 4-5 branches; media arising from radial sector from middle or a little before middle of wing-membrane and with 4-6 short branches to radial sector; cubitus with 8-9 branches to posterior margin. Abdomen elongate.

**SOLDIER (Fig. 123) :** Head-capsule yellowish to reddish brown; labrum, postclypeus and antennae yellowish brown; mandibles dark reddish brown, basally paler; thorax, legs and abdomen pale yellowish brown. Head and body fairly hairy. Total body-length 9.80-10.50 mm. Head-capsule subrectangular, longer than wide, width slightly less than 2/3rd of length (length to base of mandibles 3.25-3.31, width 2.00-2.05 mm); sides substraight, rounded posteriorly, anteriorly sometimes converging; Y-suture present; frons sloping at about 45° angle and weakly striated. Eyes oval, unpigmented; situated at about their long diameter from antennae (length 0.23-0.25 mm). Ocelli unpigmented, small spots at end of lateral arms of Y-suture. Antennae with 13+ segments; segment 3 slightly longer than 2; 4 shortest; 5 onwards gradually increasing in length. Postclypeus not clearly differentiated from frons; anteclypeus hyaline, short, strip-like. Labrum broad, tongue shaped; anterior margin rounded; with a pair of short hairs on body and a few longer ones on anterior margin. Mandibles short, thick,

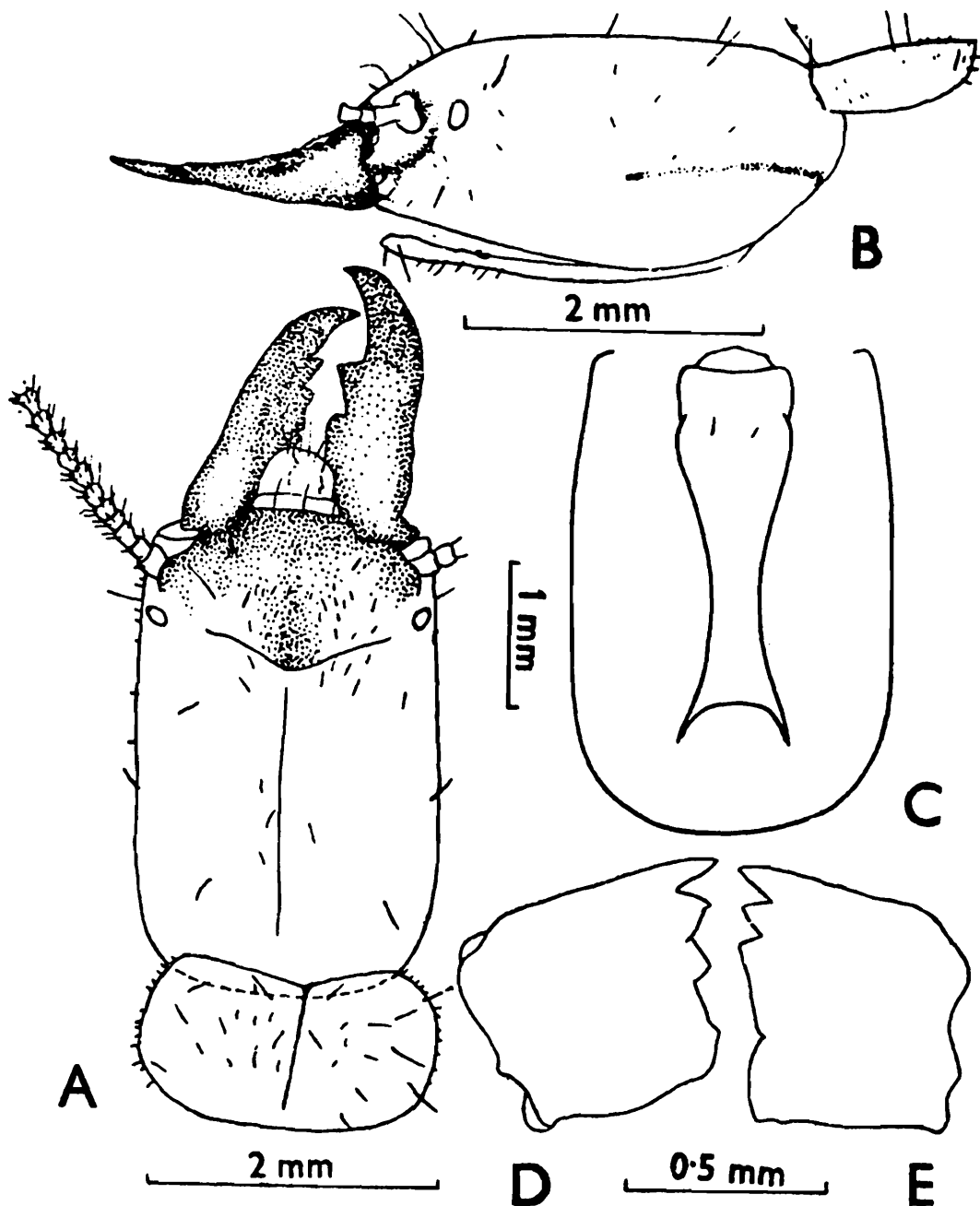

Fig. 123. *Neotermes eleanorae*. Soldier (A-C) (Holotype) and Pseudoworker (D, E). (A) Head and pronotum, in dorsal view. (B) Same, in side view. (C) Head in ventral view, showing postmentum. (D) and (E) Left and right mandibles of pseudoworker (After Bose, 1984).

1.78-1.80 mm long and weakly incurved apically; basal humps on outer margin weakly marked. Left mandible with 5 marginal teeth; 1st marginal triangular, with longer posterior margin; 2nd short and blunt; 3rd shorter and separated from 2nd by a curved margin; 4th and 5th also short. Right mandible with 2 prominent marginal teeth medially. Postmentum long,

club-shaped; club bilobed, anterior lobe, however, with straighter and posterior one with rounded sides; both lobes equally wide; sides gradually incurving to a narrow waist lying behind mid-point; width at waist less than half of maximum width; length 2.25-2.30, max. width 0.70-0.73 and width at waist 0.28-0.30 mm. Pronotum subrectangular; with rounded sides and weakly incurved anterior and substraight posterior, margins; a few short and long hairs present on body and margins. Legs short, stout and weakly pilose; tibial spurs 3:3:3; tarsi 4-jointed. Abdomen oblong, hairy; cerci 2-jointed, 0.15 mm long; styli single-jointed, 0.16 mm long.

**PSEUDOWORKER** Head pale brownish yellow; antennae paler; thorax, legs and abdomen creamish yellow. Head and body fairly hairy. Total body-length 4.80-7.00 mm. Head-capsule subcircular (length to base of mandibles 1.10-1.63, max. width 1.15-1.68 mm). Eyes unpigmented, oval, small spots. Antennae 13-segmented; segment 3 shortest, 4 and 5 subequal. Labrum broadly dome-shaped. Mandibles as in genus. Pronotum flat, subrectangular; with weakly rounded sides and incurved anterior and substraight posterior, margins; length 0.48-0.93, max. width 0.98-1.80 mm. Legs and abdomen as in soldier.

*Distribution* : INDIA : Karnataka: Mangalore (type locality).

*Biology* : This species was collected nesting in a dead branch of a mango tree at Mangalore. The nest is in the form of narrow, longitudinal, intercommunicating galleries filled with faecal pellets. The alates from the nest were collected in the month of November.

### 19. *Neotermes fletcheri* Holmgren and Holmgren (Figs. 124-127)

#### 1. *Calotermes/Kalotermes (Neotermes) fletcheri* Holmgren and Holmgren :

1917. Holmgren and Holmgren, *Mem. Dept. Agric. India (Ent.)*, 5(3): 130. Im, S, Pw. Lectotype : S (designated Roonwal and Sen-Sarma 1960), in FRI, Dehra Dun, India. Type-locality : Coimbatore, Tamil Nadu, India. Type examined.

1934. Margabandhu, *J. Bombay nat. Hist. Soc.*, 37(3): 702.

1953. Rattan Lal and Menon, *Catal. Indian Insects. Pt. 27, Isoptera* : 16.

#### 2. *Neotermes fletcheri* Holmgren and Holmgren :

1949. Snyder, *Smiths. misc. Colls.*, 112: 25.

1960. Roonwal and Sen-Sarma, *Contrib. Syst. Oriental Termites* (ICAR Ent. Monogr., 1) : 139, 141, 171-178, 265, 266, 352-355 (Pls. 38, 39).

1961. Krishna, *Bull. Am. Mus. nat. Hist.*, 122 (Art. 4) : 325.

1975. Chhotani, *Zool. Anz.*, 194 (1/2): 117.

1975. Sen-Sarma et al. *Wood Destroying Termites. (Final Tech. Rep. PL 480 Project)*: 9, 35, 51, 64.

1975. Akhtar, *Bull. Dept. Zool. Panj. Univ. (N.S.)*, Art. 7: 4, 9-10.

1980. Chhotani, *Tech. Monogr. Zool. Surv. India*, No. 4: 4, 13, 15, 71, 83, 86.

1982. Grasse', *Termitologia* vol. 1: 29.

1984. Bose, *Occ. Pap. Rec. zool. Surv. India*, No. 49: 15, 21, 22, 36, 37-39, 40, 264.

**IMAGO** (Figs. 124A, 125, 126) : Head-capsule and body above brown; pronotum somewhat paler; antennae pale brown distally, somewhat darker proximally; sternites yellowish. Head and body moderately hairy. Total body-length with wings 14.0-15.0, without wings 7.7-9.7 mm. Head-capsule subcircular, width with eyes a little more than length to base of mandibles (length 1.30-1.48, width 1.55-1.70 mm); Y-suture faint or absent. Eyes medium sized (max. diameter 0.45-0.55 mm), subcircular. Ocelli oval,

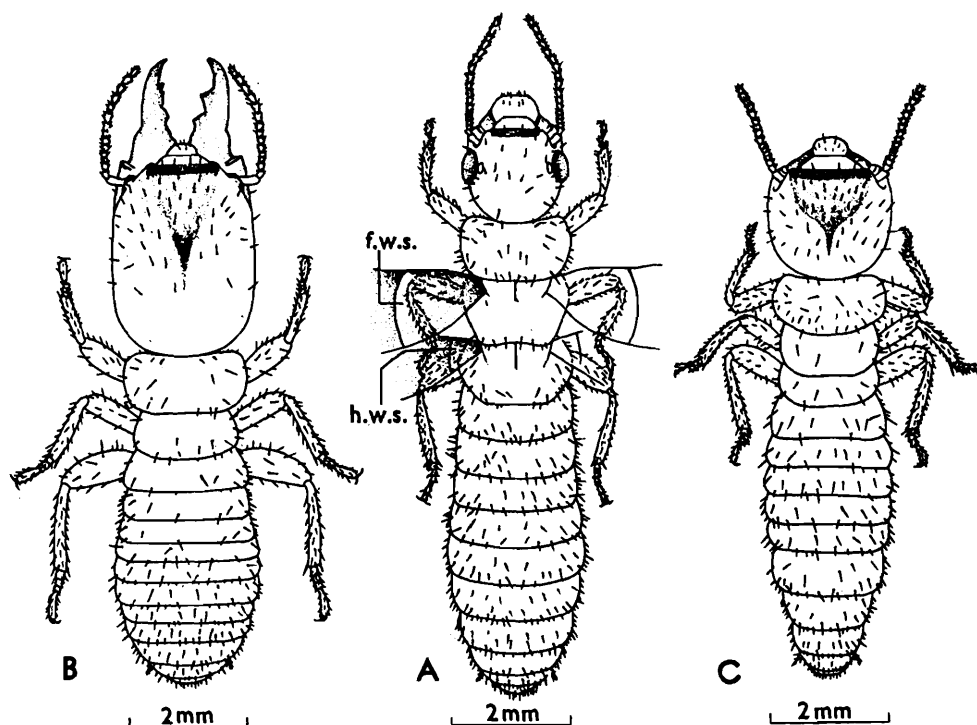

Fig. 124. *Neotermes fletcheri*. Adults, in dorsal view. (A) Imago (alate). (B) Soldier. (C) Pseudoworker. f.w.s., forewing scale; h.w.s., hindwing scl. (After Roonwal and Sen-Sarma, 1960).

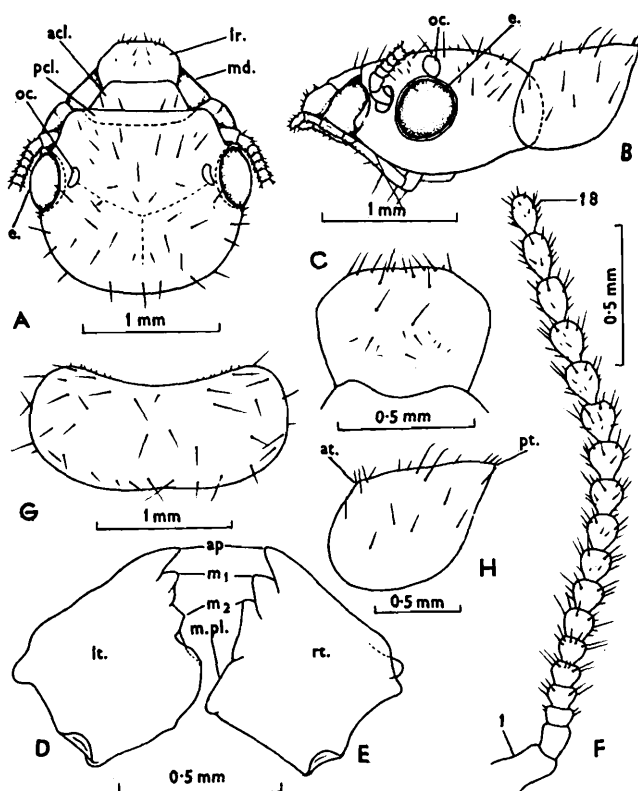

Fig. 125. *Neotermes fletcheri*. Imago. (A) Head, in dorsal view. (B) Same, in side view. (C) Labrum. (D) Left mandible. (E) Right mandible. (F) Right antenna. (G) Pronotum, in dorsal view. (H) Same, in side view. Lettering same as in fig. 108. (After Roonwal and Sen-Sarma, 1960).

translucent, touching eyes; max. diameter 0.17-0.25 mm. Antennae 18-segmented; segment 3 shortest; 4,5 subequal. Postclypeus subrectangular, shorter than in other species; with 2 pairs of hairs anteriorly; anteclypeus subtrapezoidal, hyaline, longer than postclypeus. Labrum subsquarish, rounded anteriorly; length 0.30-0.50, width 0.55-0.65 mm. Mandibles as in genus. Pronotum subrectangular, almost as wide as head with eyes (length 0.90-0.99, width 1.57-1.70 mm); anterior margin fairly incurved, without median notch; sides rounded; posterior margin substraight, with weak median incurving. Wings transparent, weakly tuberculate. Forewing: 11.7-12.15 mm long. Venation generally as in genus; subcosta meeting costa just outside scale; radius extending upto or beyond middle and then joining costa-subcosta; radial sector with 5 branches to costal margin in distal half; media with 6-8 short, transverse branches to radial sector; cubitus with 13-15 branches to posterior margin. Hindwing: 11.0-11.2 mm long. Radius extending upto a little beyond middle; radial sector giving off 5 oblique branches to costal margin; media arising from radial sector at proximal

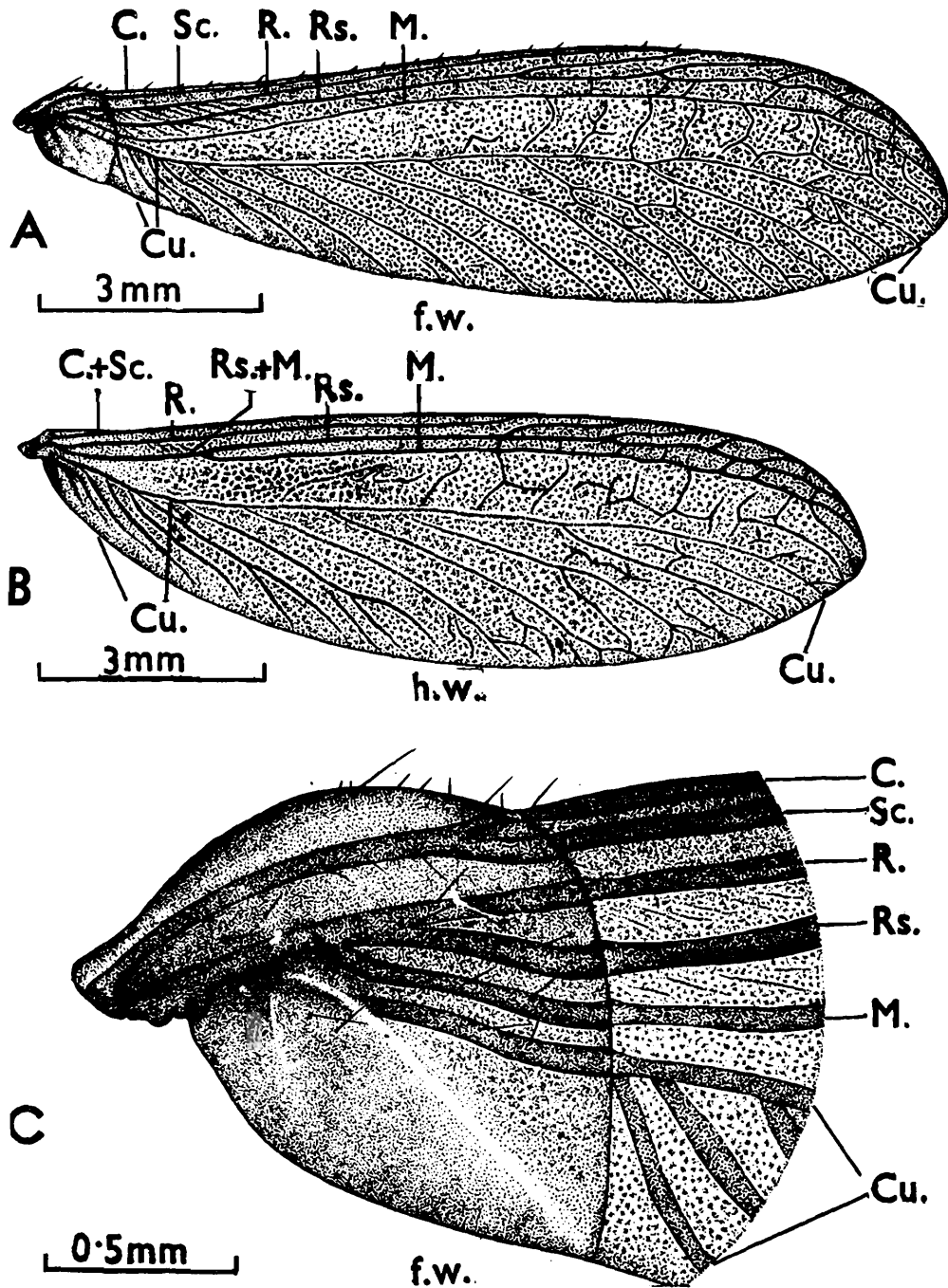
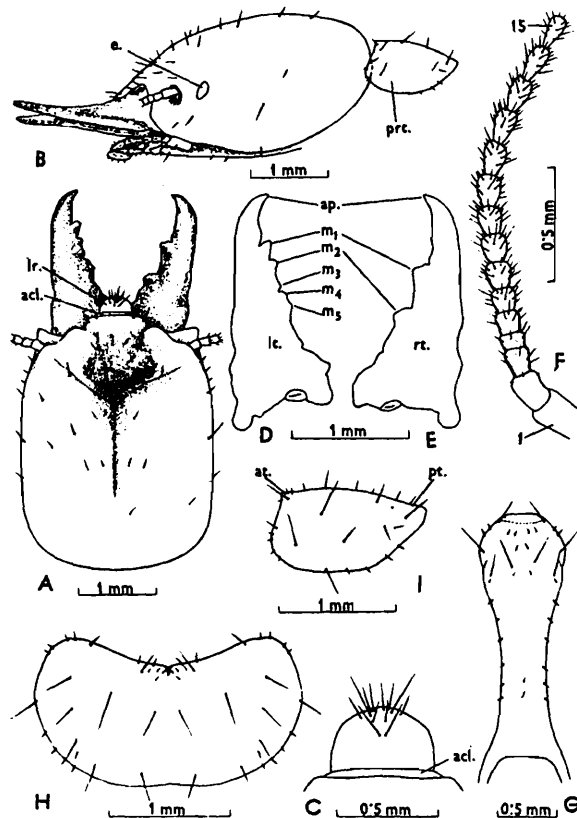

Fig. 126. *Neoterme fletcheri*. Wings. (A) Right forewing. (B) Right hindwing. (C) Basal part of right forewing including scale, enlarged. Lettering as in fig. 111. (After Roonwal and Sen-Sarma, 1960).

1/5th of wing and with 5-6 branches to radial sector; cubitus with 10-11 branches to posterior margin. Abnormally, cubitus in forewing bifurcating from within scale and media arising from it and media in hindwing arising from radial sector just outside scale. Legs slender, elongate; apical tibial spurs 3:3:3; tarsi 4-jointed; empodium darker. Abdomen elongate; cerci 2-jointed.

**SOLDIER (Fig. 127) :** Head-capsule castaneous brown; antennae and labrum brownish; mandibles black, reddish brown basally; pronotum paler than head, deep straw-coloured; body paler than pronotum. Head and body sparsely hairy. Total body-length 10.0-10.7 mm. Head-capsule broadly subrectangular; width 2/3rd to more than 3/4th of length to base of mandibles (length 2.88-3.5, width 2.0-2.46 mm); antero-lateral corners sharply projecting; frons sloping in front at  $45^\circ$  and with a median depression extending behind upto occiput; Y-suture present not prominent; posterior margin rounded. Eyes whitish, oval, maximum diameter 0.20-0.30 mm; situated at a distance of more than their long diameter from antennae. Ocelli absent. Antennae with 15 segments; antennal carinae weak; segment 3 a little shorter than 2, 4 shortest. Postclypeus rectangular, darker and slightly raised; with a pair of hairs on either side at anterior margin; anteclypeus thin, narrow, whitish strip. Labrum subrectangular with rounded anterior margin; length 0.25-0.30, width 0.42-0.54 mm. Mandibles short and stout; with weak basal humps; length 1.62-1.71 mm; a



**Fig. 127. *Neotermes fletcheri*. Soldier. (A) Head, in dorsal view. (B) Head and pronotum, in side view. (C) Labrum. (D) Left mandible. (E) Right mandible. (F) Antenna. (G) Postmentum, in ventral view. (H) Pronotum. Lettering same as in fig. 109. (After Roonwal and Sen-Sarma, 1960).**

little less than 1/2 to more than 1/2 of head, (index Mandible length/Head-length 0.48-0.59). Left mandible with 5 and right with 2 marginals (Fig.127 D, E). Postmentum long, club-shaped, more hairy than in other species; club-bilobed; waist long but not very narrow; length 1.83-2.10, maximum width 0.72-0.80, width of waist 0.30-0.42 mm. Pronotum subrectangular, with rounded sides; anterior margin fairly to strongly incurved with median notch, posterior margin convex with a median invagination; much narrower than head (length 1.0-1.34, width 1.90-2.22 mm). Legs long, slender, hind femora more swollen than in other species, each tibia with 3 spurs; tarsi 4-jointed. Abdomen elongate, each tergum with a row of hairs at posterior margin; cerci 2-jointed.

**PSEUDOWORKER** : Head-capsule deep straw coloured; labrum, antennae and pronotum much paler; abdomen whitish. Head and body sparsely pilose. Total body-length 7.5-9.0 mm. Head-capsule subcircular, width subequal to length to base of mandibles (length 1.7-1.8, width 1.9-2.0 mm). Antennae 15-segmented, segment 3 longer than 4 and 5 put together; 2 longer than 3. Postclypeus subrectangular with 2 pairs of hairs anteriorly; anteclypeus trapezoidal, whitish, longer than postclypeus. Labrum subsquarish with short hairs at anterior margin and body. Mandibles as in genus. Pronotum subrectangular, narrower than head; anterior margin concave; posterior margin weakly convex; sides rounded; length 0.8-0.9, width 1.5-1.8 mm. Legs and abdomen as in soldier.

**Distribution** : INDIA : Tamil Nadu : Coimbatore. BANGLADESH : Rajshahi.

**Biology** : The species is reported to attack stem and branches of *Moringa pterygosperma* and *Delonix regia* trees and dead logs of wood. The nest like that of other species is in the form of irregular galleries filled with faecal pellets. The alates have been found in the nests during September to December.

## 20. *Neotermes greeni* (Desneux) (Figs. 128-130)

### 1. *Calotermes greeni* Desneux :

1908. Desneux, *Ann. Soc. Ent. Belg.*, 51: 388-389. Imago and soldier. Holotype : Repository not known. Type-locality : Sri Lanka.

1911. Holmgren, in Escherich's *Termitenleben auf Ceylon* : 189.
1911. Holmgren, K. *Sv. Vet. Acad. Handl.*, 46(6): 54.
1913. Green, *Spolia Zeylanica*, 9(33): 8.
1914. Bugnion, *Bull. Mus. Hist. nat. Paris*, 20(4): 175-176.
1926. Kemner, *Bull. ent. Res.*, 16(4): 382-383.
1937. King, *Tea Quart.*, 19(3): 166.
2. *Calotermes/Kalotermes (Neotermes) greeni* Desneux :
1910. Bugnion, *Mem. Soc. Zool. Fr.*, 23: 125-137.
1913. Holmgren, K. *Sv. Vet. Akad. Handl.*, 50(2): 44-45.
1914. Holmgren, *Zool. Jb.*, 36(2-3): 233.
1934. Margabandhu, *J. Bombay nat. Hist. Soc.*, 37(3): 703.
1953. Rattan Lal and Menon, *Catal. Indian Insects, Pt. 27, Isoptera* : 17-18.
3. *Neotermes greeni* (Desneux) :
1937. Light, *Pan-Pacific Ent.*, 13(1-2): 15.
1941. Pinto, *Indian J. Ent.*, 3(1): 80-81.
1949. Snyder, *Smiths. misc. Colls.*, 112: 26.
1953. Roonwal and Pant, *Indian For. Leaflet (Ent.)*, No. 121(3): 45.
1960. Roonwal and Sen-Sarma, *Contrib. Syst. Oriental Termites* (ICAR Ent. Monogr. 1): 139, 140, 142, 181-188, 265, 266, 358-361 (Pls. 41, 42).
1961. Krishna, *Bull. Am. Mus. nat. Hist.*, 122 (Art. 4) : 325.
1961. Roonwal and Chhotani, *Proc. Sym. Timber Allied Products* (New Delhi 1960): 89.
1962. Fernando, In *Termites Humid Tropics* (Proc. New Delhi Symp., 1960): 205, 207.
1967. Roonwal and Chhotani, *J. Bombay nat. Hist. Soc.*, 63(2): 356.
1975. Chhotani, *Zool. Anz.*, 194(1/2): 117.
1980. Chhotani, *Tech. Monogr. Zool. Surv. India*, No. 4: 4, 15-16, 83, 85.
1984. Grasse', *Termitologia* Vol. 2: 157.
1984. Bose, *Occ. Pap. Rec. zool. Surv. India*, No. 49: 30, 37, 45, 51.

IMAGO (Figs. 128, 129): Head-capsule, pronotum and abdomen brown above; antennae, legs and abdominal sternites pale brownish yellow; wing-scales and veins brownish, wing membrane transparent. Head and body fairly pilose with long and short hairs. Total length with wings 13.70-15.0, without wings 7.5-9.5 mm. Head-capsule subsquarish, maximum width

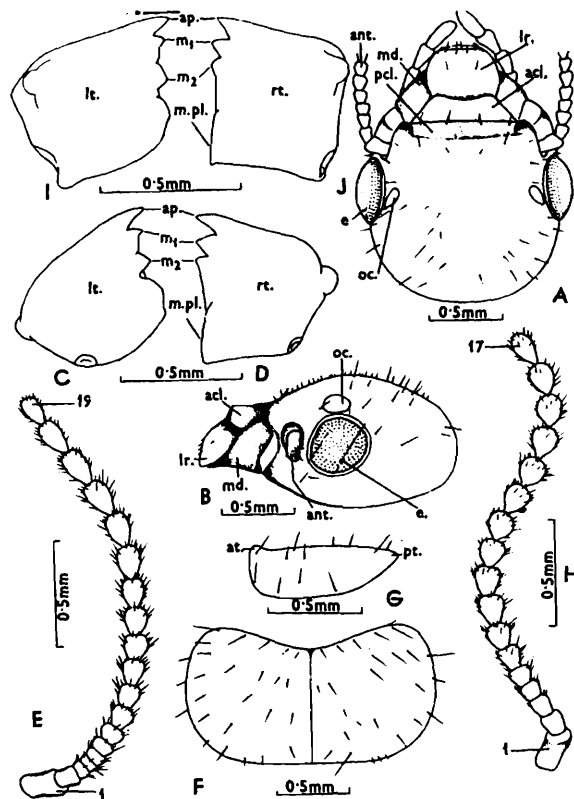

Fig. 128. *Neotermes greeni*. Imago (A-H), Pseudoworker (I-J). (A) Head, in dorsal view. (B) Head, in side view. (C) Left mandible. (D) Right mandible. (E) Right antenna (19-segmented). (F) Pronotum, in dorsal view. (G) Same, in side view. (H) Left antenna (17-segmented). (I) Left mandible. (J) Right mandible. Lettering same as in fig. 108. (After Roonwal and Sen-Sarma, 1960).

subequal to length to base of mandibles (width with eyes 1.40-1.55, length 1.20-1.50 mm); head arched in profile; Y-suture indistinct. Eyes large, subcircular, 0.45-0.55 mm in diameter; lying close to antennae, minimum eye-antennal distance 0.025-0.038 mm. Ocelli elongately oval (long diameter 0.20-0.22 mm), whitish, translucent, lying close to but not touching eyes (eye-ocular distance 0.013-0.025 mm). Antennae with 16-19 segments, 2 twice as long as 3 (19 segmented) or subequal to 3 (17 segmented); 3 longer or subequal to 4; from 5 gradually increasing in length. Postclypeus rectangular, darker than rest of head; with 2 pairs of hairs on anterior margin. Anteclypeus apilose, trapezoidal, narrow; longer than postclypeus. Labrum straw-coloured, subsquarish (length 0.4, width 0.5 mm); with 3-4 hairs on tip and one pair on body. Mandibles as in genus. Pronotum subrectangular, fairly pilose with long and short hairs; anterior margin deeply incurved, not notched; posterior margin straight with a faint median incurving; sides rounded; width about twice length (length 0.8-0.9, width 1.5-1.9 mm); and almost as wide as or a little broader than head-

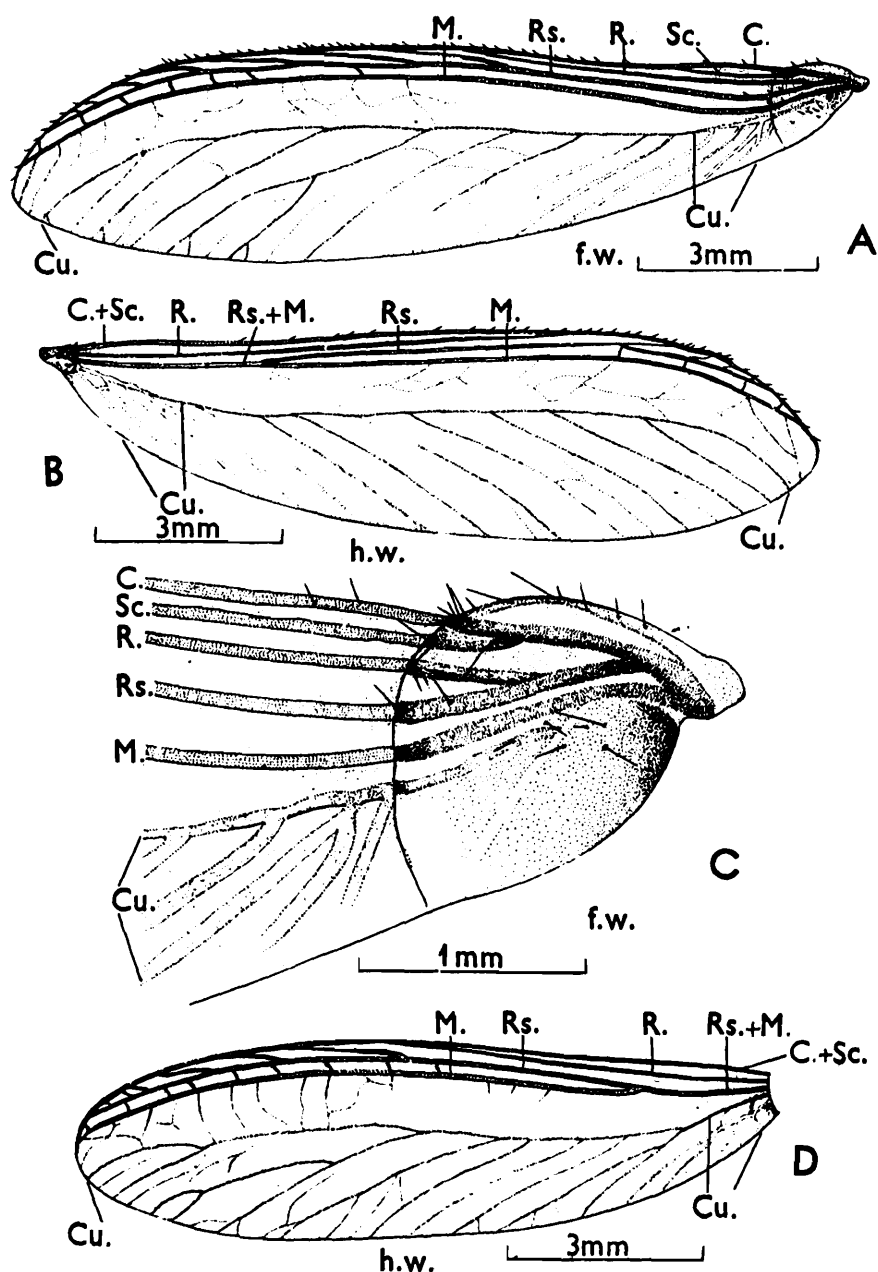

Fig. 129. *Neotermes greeni*. Wings. (A) Left forewing. (B) Right hindwing. (C) Left forewing, proximal part with scale, enlarged. (D) Left hindwing, showing variation in wing venation. Lettering same as in fig. 111 (After Roonwal and Sen-Sarma, 1960).

width with eyes. Legs slender, hairy; apical tibial spurs 3:3:3; tarsi 4-jointed; empodium brown. Wings transparent, neither hairy nor tuberculate. Forewing : Length c 14.5 mm. Subcosta short, meeting costa just outside scale; radius fusing with costa-subcosta little before middle; radial sector with 7 oblique branches to costal border; media with 6 transverse veins to

radial sector; cubitus with 11-13 branches to posterior margin. Hindwing : Length 12.0-13.0 mm. Radius meeting costa-subcosta at 1/2 to 2/3rd of wing-length. Radial sector with 4-6 branches; media arising from radial sector in proximal 1/4 to 1/3rd, and connecting with it by 6-8 transverse veins; cubitus with 10-13 branches. Abdomen elongate, slender, each tergum with 2 rows of sparse hairs; cerci 2-jointed.

**SOLDIER (Fig. 130) :** Head-capsule pale brown to dark brown; antennae brownish, basally paler; mandibles black, basally reddish brown; body and legs yellowish to pale brown. Head and body fairly pilose with long and short hairs. Total body-length 9.0-11.0 mm. Head-capsule subrectangular, sides subparallel; width about 2/3rd to almost 3/4th of length (length 1.8-3.5, width 1.07-2.4 mm; index Width/Length 0.68-0.74); frons sloping in front at about 45° and medially shallowly depressed; Y-suture distinct. Eyes suboval, translucent, 0.18-0.30 mm long; situated at about their length from antennae. Ocelli absent. Antennae with 14-16 segments; antennal

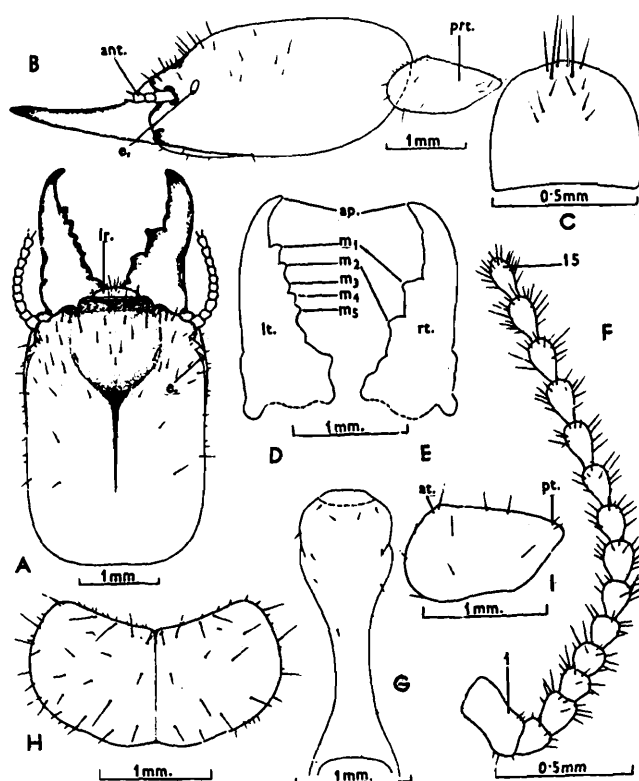

Fig. 130. *Neotermes greeni*. Soldier. (A) Head, in dorsal view. (B) Head and pronotum, in side view. (C) Labrum. (D) Left mandible. (E) Right mandible. (F) Right antenna. (G) Postmentum, in ventral view. (H) Pronotum, in dorsal view. (I) Pronotum, in side view. Lettering same as in fig. 109 (After Roonwal and Sen-Sarma, 1960).

carinae weakly developed, segment 3 somewhat longer than 2, 4 subequal to or slightly smaller than 2. Postclypeus flat, subrectangular, darker than frons and with 2 pairs of hairs on anterior margin; anteclypeus whitish, prominent, narrow, strip-like. Labrum subsquarish; anteriorly rounded; with hairs on tip and body (length 0.25-0.35, width 0.50-0.60 mm). Mandibles thick and stout; length about 1/2 to 2/3 rd of head-length (length 1.62-1.80 mm, index Mandible-length/Head-length 0.51-0.61); not humped basally. Left mandible with 5 marginals and right with 2 large marginals. Postmentum long, club-shaped; anterior broader part bilobed; anterior lobe larger; posteriorly with a long, narrow stalk, width at waist about 1/3rd of max. width; median length 1.98-2.50, max. width 0.75-0.90, width at waist 0.25-0.30 mm. Pronotum subrectangular, about as wide as head and its width nearly twice of length (length 0.81-1.40 mm, width 1.71-2.30 mm); anterior margin deeply concave and medially notched; posterior margin convex, with median incurving; sides rounded. Legs long, slender; apical tibial spurs 3:3:3; tarsi 4-jointed. Abdomen elongate, each tergum with 2 rows of hairs; cerci 2-jointed.

**PSEUDOWORKER** : Head-capsule straw-coloured; antennae, legs and body pale yellowish. Head and body moderately hairy. Total body-length 7.5-9.0 mm. Head-capsule subcircular, almost as wide as length to base of mandibles (length 1.5-1.70, width 1.65-1.80 mm); Y-suture indistinct. Eyes small, whitish spots. Antennae with 15-16 segments; segment 2 longer than 3; 3,4 and 5 subequal. Postclypeus flat, rectangular, darker than frons; anteclypeus whitish, trapezoidal. Mandibles as in genus. Pronotum subrectangular, as wide as head (length 0.75-0.90, width 1.55-1.89 mm); anterior margin deeply incurved and weakly notched medially; posterior margin convex, with or without median incurving; sides rounded. Legs and abdomen as in soldier.

**Distribution** : SRI LANKA : Widely distributed throughout the country from sea-level to 1500 m elevation. For detailed distribution vide Roonwal and Sen-Sarma, 1960.

**Biology** : It is recorded from a number of plants and is a pest of some importance of tea plantations, for host plants vide Chhotani, 1980.

**21. *Neotermes kalimpongensis* Maiti**  
(Figs. 131, 132)

*Neotermes kalimpongensis* Maiti :

1975. Maiti, *Oriental Insects*, 9(2): 139-143. S, Pw. Holotype: S, in ZSI, Calcutta Type-locality : Bong Basti, Kalimpong (West Bengal, India). Type examined.

1983. Maiti, *Occ. Pap. Rec. zool. Surv. India*, No. 42 : 11, 31-32.

IMAGO Unknown.

**SOLDIER (Fig. 131) :** Head-capsule brownish; antennae, postclypeus and labrum somewhat darker; mandibles black, blackish brown basally; legs and body yellowish white. Head and body sparsely hairy. Total body-length 13.50-15.50 mm. Head-capsule subrectangular, parallel sided (length to base of mandibles 3.80-4.20, max. width 2.70-2.80 mm); width about 2/3rd

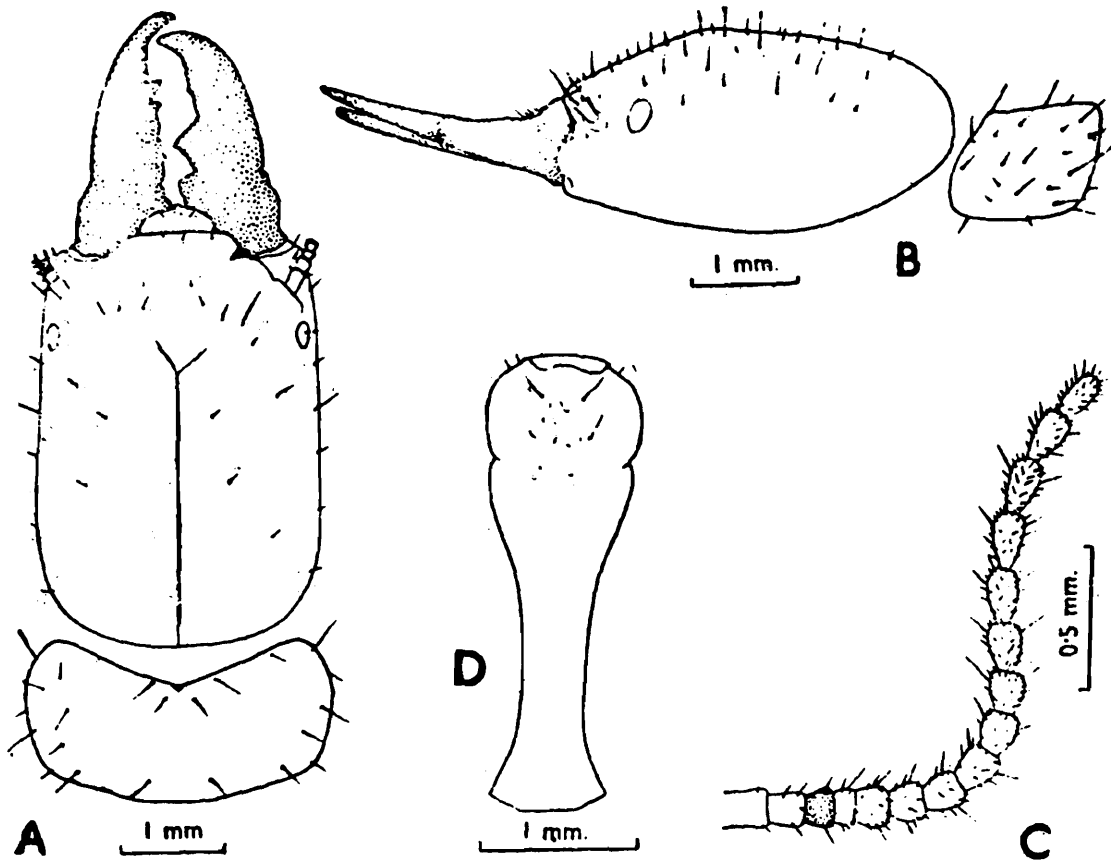

Fig. 131. *Neotermes kalimpongensis*. Soldier. (A) Head and pronotum, in dorsal view. (B) Same, in side view. (C) Antenna. (D) Postmentum (After Maiti, 1975).

of length (index Width/Length 0.64-0.72); posterior margin rounded; frons sloping anteriorly and slightly depressed medially; Y-suture distinct. Eyes oval (long diameter 0.32-0.37, short diameter 0.21-0.25 mm); situated at about their short diameter from antennae. Ocelli absent. Postclypeus not clearly demarcated from frons; with a pair of short hairs anteriorly on either side. Anteclypeus apilose, hyaline, strip-like. Labrum broader than long; anteriorly rounded (length 0.48-0.55, width 0.72-0.81 mm). Antennae with 15-16 segments; segment 3 strongly chitinised, shorter than 2 (16-segmented antennae) or cone-shaped and longer than 2 and about twice as long as 4 (15-segmented antennae). Mandibles short, stout and with prominent basal humps on outer margin near base; a little longer than half of head-length to base of mandibles (length 2.24-2.30 mm, Mandible-length/Head length index 0.53-0.58). Left mandible with 5 marginals; 1st and 2nd marginals fairly prominent; 3rd and 4th weak; margin between 2nd and 3rd long; 5 larger than 3rd or 4th. Right mandible with 2 median, prominent marginals. Postmentum long, club-shaped; broadest at anterior lobe of club; narrowing behind to a long, narrow waist; width at waist a little more than 1/3rd of max. width (length 2.80-3.00, max-width 0.90-0.92, width at waist 0.33-0.37 mm). Pronotum flat, subrectangular; a little broader than head (length 1.16-1.20, max. width 2.85-2.90 mm; Pronotum-width/Head-width index 1.02-1.04); anterior margin fairly deeply incurved and with a median notch; sides rounded; posterior margin convex. Legs short and stout; apical tibial spurs 3:3:3; middle tibia sometimes having an extra spur; tarsi 4-jointed. Abdomen elongate; cerci and styli present.

**PSEUDOWORKER** (Fig. 132) Head creamish white; antennae, legs and body of same colour as head; labrum and postclypeus slightly darker. Total body-length 6.00-11.00 mm. Head-capsule subcircular, a little broader than long (head-length to base of mandibles 1.70-2.10, head-width 2.00-2.20 mm). Eyes rudimentary, unpigmented. Postclypeus flat, short, with a few hairs anteriorly; anteclypeus hyaline, apilose. Labrum dome-shaped, broader than long (length 0.48-0.55, width 0.70-0.80 mm). Mandibles as in genus. Pronotum broader than head, flat, fairly deeply incurved at anterior margin and medially notched; posterior margin convex, medially invaginated (length 1.17-1.30, width 2.30-2.50 mm). Legs and abdomen as in soldier.

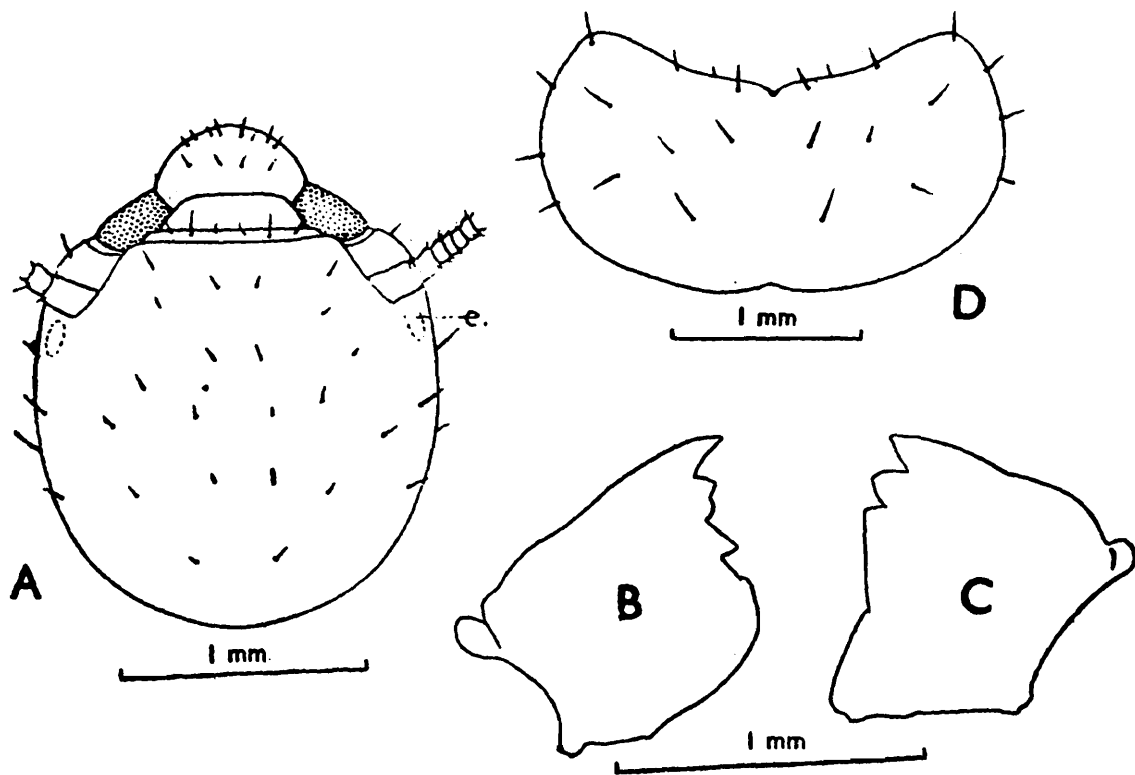

Fig. 132. *Neotermes kalimpongensis*. Pseudoworker. (A) Head in dorsal view. (B) and (C) Left and right mandibles. (D) Pronotum, in dorsal view.<sup>1</sup>

**Distribution :** INDIA : West Bengal : Bong Bosti (Kalimpong, Darjeeling Dist.), alt. 1209 m, known only from type-locality.

**Host :** *Ficus* sp. live tree (type-host).

## 22. *Neotermes kemneri* Roonwal and Sen-Sarma (Fig. 133)

*Neotermes kemneri* Roonwal and Sen-Sarma :

1960. Roonwal and Sen-Sarma, *Contrib. Syst. Oriental Termites* (ICAR Ent. Monogr. 1): 139, 142, 188-190, 267, 362-363 (Pl. 43). S, Pw. Holotype : S, in Entomologiska Avdelningen, Zoological Institute, Lund University, Lund, Sweden. Type-locality : Gannoruwa, Peradeniya, Sri Lanka. Type examined.
1962. Roonwal. *Termites in Humid Tropics* (Proc. New Delhi Symp., 1960) : 40.
1967. Roonwal and Chhotani, *J. Bombay nat. Hist. Soc.*, 63(2) : 362.
1975. Chhotani, *Zool. Anz.*, 194(1/2) : 117.
1982. Grassé, *Termitologia* Vol. 1: 33.

**IMAGO Unknown.**

**SOLDIER** (Fig. 133) : Head-capsule deep yellow to straw-coloured; antennae basally brownish, distally paler; mandibles reddish brown, teeth blackish; pronotum, legs and body yellowish to pale brown. Pilosity fairly thick. Total body-length c 7.40-8.50 mm. Head-capsule fairly long, subrectangular (length of head to base of mandibles 2.52-2.82, width 1.86-2.04 mm); frons sloping in front, with a shallow depression extending backwards upto middle of head; Y-suture distinct. Eyes suboval, whitish, maximum diameter 0.18 mm; minimum eye-antennal distance subequal to or a little more than long diameter of eye (eye-antennal distance 0.18 mm). Ocelli absent. Antennae with 13-14 segments, segment 3 longer than 2, segment 4 subequal or shorter than 2. Postclypeus darker than frons, subrectangular, with 2 pairs of hairs on anterior margin; anteclypeus whitish, fairly prominent. Labrum short, length less than width (length 0.24-0.30, width 0.42-0.48 mm); anterior margin rounded. Mandibles robust, long, about 2/3rd of head-length, length of mandibles 1.62-1.68 mm, index Mandible-length/Head-length 0.58-0.64; left mandible with 6 marginal teeth; right with 2 marginals. Postmentum elongate (length 1.74-2.04 mm), club-shaped; broadest anteriorly (maximum width 0.60-0.72 mm); narrowing to a long waist (width 0.18-0.24 mm); anterior club faintly divided into a larger anterior part and a slightly smaller posterior half; with a few hairs on the anterior half. Pronotum subrectangular (width 1.56-1.92, length 0.90-1.02 mm); fairly pilose; width a little less than to subequal to head-width (Pronotum-width/Head-width index 0.84-0.97); anterior margin convex, invaginated medially. Legs long, slender, sparsely hairy; apical tibial spurs 3:3:3; tarsi 4-segmented. Abdomen elongate with 2 rows of hairs on each tergum; cerci 2-segmented.

**PSEUDOWORKER** : Head-capsule labrum and mandibles straw-coloured; mandibular-teeth brownish; antennae, pronotum, body and legs yellowish; head and body pilose. Total body-length 5.0-6.5 mm. Head-capsule rounded, length of head to base of mandibles 1.2-1.4, head-width 1.25-1.69 mm; Y-suture indistinct. Eyes present as small, whitish spots. Ocelli absent. Antennae 13-14 segmented. Pronotum subrectangular, narrower than head with eyes (length 0.4-0.70, width 0.90-1.35 mm).

*Distribution* : SRI LANKA : Gannoruwa (Peradeniya), type-locality.

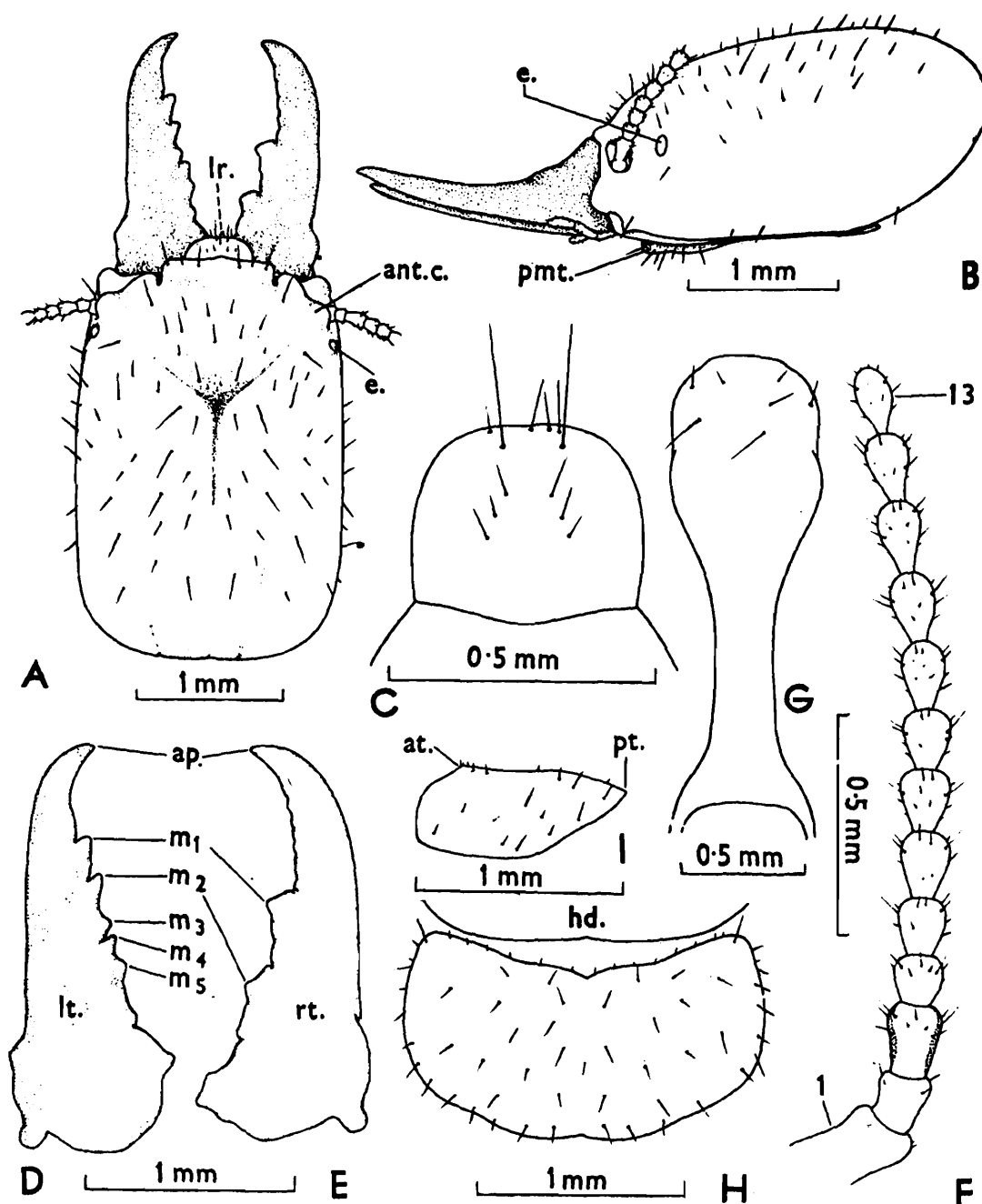

Fig. 133. *Neotermes kemneri*. Soldier. (A) Head, in dorsal view. (B) Same, in side view. (C) Labrum. (D) Left mandible. (E) Right mandible. (F) Right antenna. (G) Postmentum, in ventral view. (H) Pronotum, in dorsal view. (I) Same, in side view. Lettering same as fig. 109. (After Roonwal and Sen-Sarma, 1960).

### 23. *Neotermes keralai* Roonwal and Verma (Fig. 134)

*Neotermes keralai* Roonwal and Verma :

1972. Roonwal and Verma, *Proc. Natnl. Acad. Sci. India*, 41(B) III : 251-256.  
Holotype : S, in ZSI, Calcutta. Type-locality: Chackai, Trivandrum, Kerala, India.  
Type examined.

1975. Chhotani, *Zool. Anz.*, 194 (1/2): 117.

1979. Thakur, *J. Indian Acad. Wood. Sci.*, 9(1): 61.

1984. Bose, *Occ. Pap. Rec. zool. Surv. India*, No. 49: 22, 39-40, 264.

IMAGO : Unknown.

**SOLDIER** (Fig. 134) Head brown, darker distally, mandibles basally dark brown, distally blackish; anteclypeus whitish; antennae whitish,

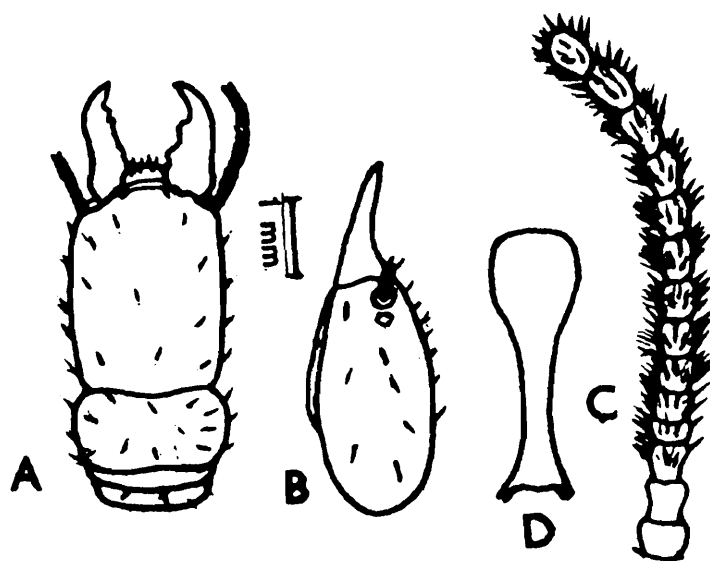

Fig. 134. *Neotermes keralai*. Soldier. (A) Head and thorax, in dorsal view. (B) Head, in side view. (C) Antenna. (D) Postmentum. (Redrawn from Roonwal and Verma, 1972).

proximal segments brownish; thorax and abdomen straw-coloured; legs dirty white. Head sparsely and thorax and abdomen fairly, pilose. Total length c 8.5-10.0 mm. Head long, subrectangular; length of head to lateral base of mandibles 3.16-3.42, head-width 2.10-2.39 mm; frons sloping in front. Eyes small (maximum diameter of eye 0.18, minimum diameter 0.14 mm); situated very close to antennae. Ocelli absent. Antennae pilose, with 14-15 segments, segment 2 longer than 3, 4 shortest. Postclypeus with short hairs, fairly broad; anteclypeus narrow, whitish. Labrum subsquarish, with a few hairs near rounded anterior margin. Mandibles short, robust (length 1.84-1.89); a little longer than 1/2 of head (Mandible-length/Head-length Index 0.54-0.58); left mandible with 5 marginal teeth; right with 2 prominent marginal teeth. Postmentum long (length 2.10-2.53, maximum width 0.68-0.89); anterior part very wide and club-shaped; waist long and

narrow (0.3-0.4 mm). Pronotum as broad as or slightly broader than head, (length 1.05-1.58, width 2.10-2.74 mm), pilose; anterior margin weakly concave, with weak median notch. Legs short, stout, femora somewhat swollen; apical tibial spurs 3:3:3; tarsi 4 jointed. Abdomen pilose; cerci and styli short, pilose.

**PSEUDOWORKER** Head-capsule straw-coloured; antennae and body paler. Head subrounded (length to lateral base of mandibles 1.58, width 1.84-1.89 mm). Eyes and ocelli absent. Labrum dome-shaped (length 0.39-0.42, width 0.47-0.58 mm); anteriorly rounded; with a few short stiff hairs. Antennae short, with 15 segments, 3 shorter than 2, 4 shortest. Mandibles as in genus. Pronotum subrectangular (length 0.95-1.05, width 1.81-2.10 mm); slightly wider than head; anterior margin markedly and posterior margin weakly, concave. Legs and abdomen as in soldier.

*Distribution* : INDIA : Kerala : Trivandrum, type-locality.

#### 24. *Neotermes krishnai* Bose

(Figs. 135, 136)

1984. *Neotermes krishnai* Bose, *Occ. Pap. Rec. zool. Surv. India*, No. 49: 15, 23, 41-45, 254, 264. S, Pw. Holotype : S, in ZSI, Calcutta. Type-locality : Salem (Tamil Nadu, India). Types examined.

**IMAGO** : Unknown.

**SOLDIER** (Fig. 135) : Head-capsule brownish, paler medially; postclypeus and labrum slightly darker; anteclypeus hyaline; mandibles dark brown, reddish brown basally; antennae pale golden yellow; thorax, legs and body creamish yellow. Head and body sparsely hairy. Total body-length 9.8-11.5 mm. Head-capsule subrectangular; width about 3/4th of length or a little less (length to base of mandibles 3.20-3.35, width 2.28-2.45 mm); sides substraight, slightly widening anteriorly near antennae; posteriorly rounded; Y-suture present, prominent; frons slightly depressed and sloping in front at about 45° angle. Eyes translucent, oval (0.33-0.36 mm long); at about their short diameter from antennae. Ocelli minute, whitish spots at end of lateral arms of Y-suture. Postclypeus flat, subrectangular, not clearly separated from frons; with a pair of bristles on either side near anterior margin and a pair medially. Anteclypeus thin, hyaline, apilose, strip-like. Labrum broadly tongue-shaped; apically broadly rounded; with a few, long

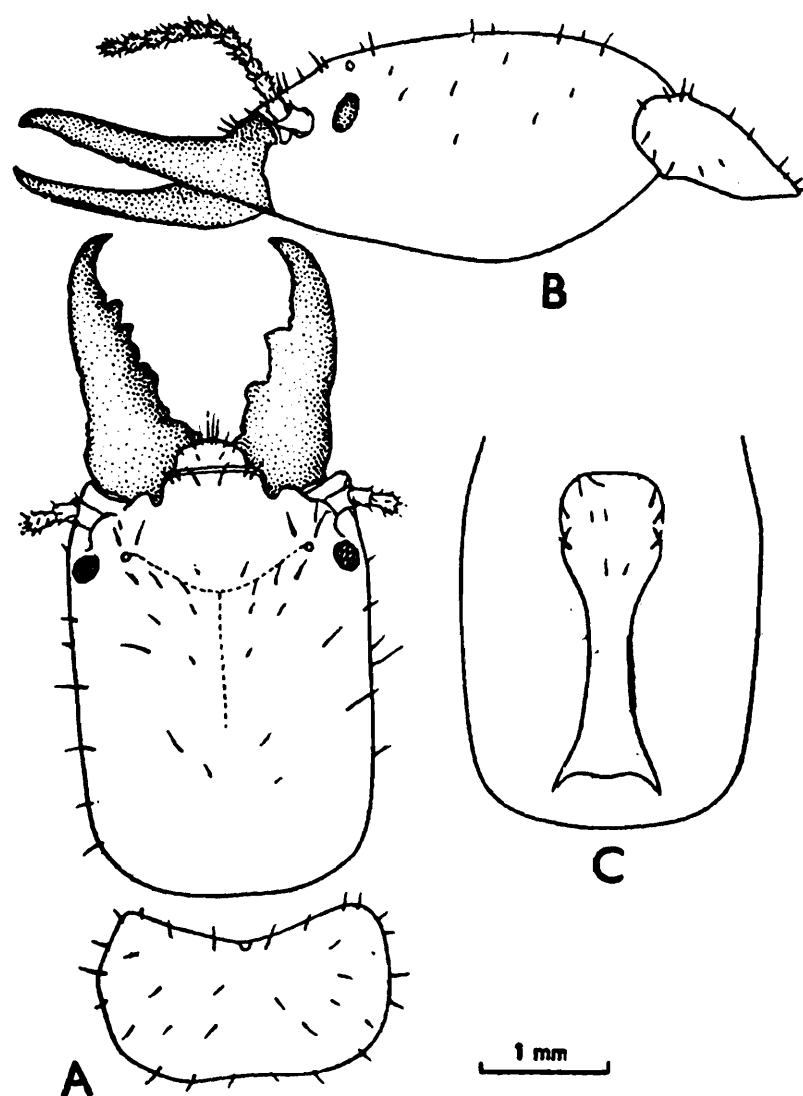

Fig. 135. *Neotermea krishnai*. Soldier. (A) Head and pronotum, in dorsal view. (B) Same, in side view. (C) Head in ventral view, showing postmentum. (After Bose, 1984).

and short hairs near anterior margin and on body. Antennae with 12 segments; segment 3 longer than 2 and strongly sclerotised; 4 shortest. Mandibles short, thick, with weak basal humps on outer margin, 1.95-2.00 mm long; a little less than 2/3rd of head length (index Mandible-length/Head-length to base of mandibles 0.60-0.62). Left mandible with 6 marginal teeth. Right with 2 large marginals, situated medially. Postmentum long, club-shaped; club bilobed with anterior lobe as wide as posterior one; waist long and narrow, width at waist less than half its width at club; median length 2.25-2.45, width at club 0.80-0.85, width at waist 0.30-0.33 mm. Pronotum flat, subrectangular; almost as wide as head (length 1.15-1.23, width 2.13-2.38 mm); anterior margin fairly deeply incurved; sides rounded; posterior margin substraight with slight median incurving. Mesonotum and

metanotum semicircular; former narrower than pronotum and latter a little wider than mesonotum but narrower than pronotum. Legs short, stout, sparsely hairy; apical tibial spurs 3:3:3; tarsi 4-jointed. Abdomen oblong, hairy; cerci 2-jointed, 0.10 mm long; styli single-jointed, long, narrow and 0.15 mm long.

**PSEUDOWORKER** (Fig. 136) Head-capsule creamish yellow; labrum somewhat darker; body a little paler. Total body-length 5.10-7.00 mm. Head-capsule subcircular; slightly wider than its length to base of mandibles (length 1.00-1.70, width 1.18-1.90 mm). Eyes fairly large, translucent and oval; about 0.25 mm in long diameter. Postclypeus flat, subtrapezoidal, not clearly differentiated from frons and with a few short hairs; anteclypeus hyaline, apilose. Labrum roundly tongue-shaped. Antennae 15-17 segmented; segment 4 shortest; 2 longer than 3. Mandibles typically *Neotermes*. Pronotum subrectangular; anterior margin weakly incurved; sides and posterior margin rounded (length 0.55-0.90, width 1.03-1.75 mm). Legs and abdomen as in soldier.

*Distribution* : INDIA Tamil Nadu : Salem (type-locality).

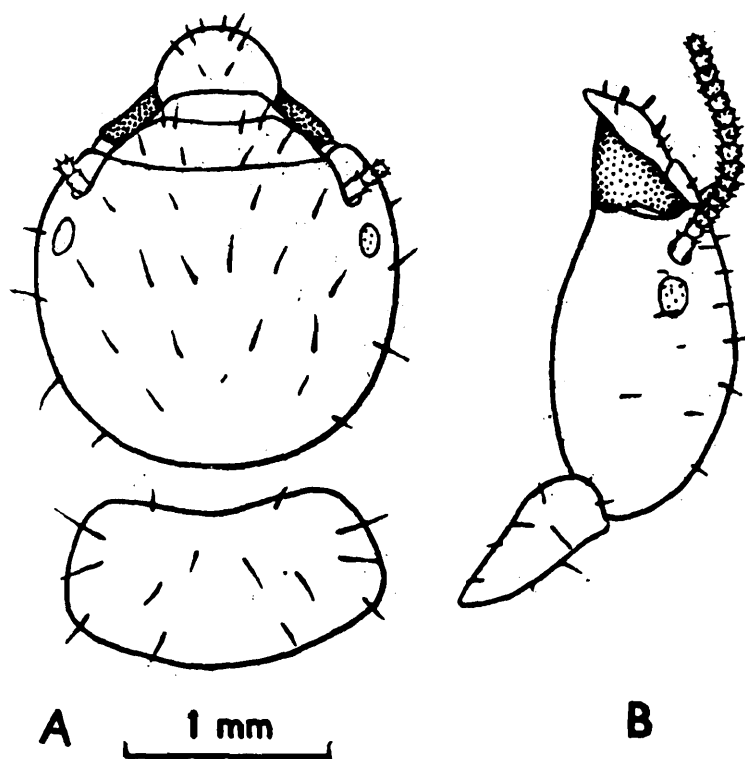

Fig. 136. *Neotermes krishnai*. Pseudoworker. (A) Head and pronotum in dorsal view. (B) Same, in side view. (After Bose, 1984).

## 25. *Neotermes mangiferae* Roonwal and Sen-Sarma (Fig. 137)

*Neotermes mangiferae* Roonwal and Sen-Sarma :

1960. Roonwal and Sen-Sarma, *Contrib. Syst. Orient. Termites* (ICAR Ent. Monogr. 1) : 139, 143, 208-211, 270, 378-379 (pl. 51). S, Pw. Holotype : S, in FRI, Dehra Dun. Type-locality : Eastern India. Type examined.
1962. Roonwal, *Termites in Humid Tropics* (Proc. New Delhi Symp. 1960): 40.
1967. Roonwal and Chhotani, *J. Bombay nat. Hist. Soc.*, 63(2) : 362.
1975. Chhotani, *Zool. Anz.*, 194(1/2): 118.
1975. Sen-Sarma et al. *Wood Destroying Termites of India (Final Tech. Rep. PL 480 Project)*: 10, 35, 64.
1980. Chhotani, *Tech. Monogr. Zool. Surv. India*, No. 4: 4, 16-17.
1983. Maiti, *Occ. Pap. Rec. zool. Surv. India*, No. 42: 22, 23.

IMAGO : Not known.

**SOLDIER** (Fig. 137) : Head-capsule brown, darker anteriorly; antennae brownish, distally somewhat paler; labrum dark brown; mandibles blackish, dark brown basally; pronotum pale straw-coloured to yellowish, with pale irregular patches; abdomen and tibiae yellowish, femora and coxae whitish. Head and body sparsely hairy. Total body-length c 9.8-10.5 mm. Head-capsule elongate, subrectangular; sides subparallel; frons sloping in front at about 45° angle, with median depression extending behind upto middle; Y-suture prominent. Eyes oval, whitish, prominent, 0.25-0.30 mm long; situated at a little less than their length from antennae, 0.18 mm. Antennae with 13-16 segments; antennal carinae weakly developed; segment 3 as long as 2; 4 shortest. Postclypeus subrectangular, not clearly demarcated from frons, with 2 pairs of hairs anteriorly; anteclypeus narrow, whitish strip. Labrum short, rectangular, subsquarish, rounded anteriorly; with an obtuse tip (length 0.18-0.30, width 0.42-5.0 mm). Mandible short, stoutly built, strongly humped basally at outer margin; a little less than to a little more than half of head-length (length 1.50-1.68 mm, index Mandible-length/Head length 0.47-0.53). Left mandible with 4 and right with 2 large marginal teeth (Fig. 137 D,E). Postmentum long, club-shaped; anterior broader part (club) bilobed; stalk thick, width at waist about 1/2 of max. width at club; length 2.10-2.40, max. width 0.70-0.84, min. width 0.36-0.42 mm. Pronotum subrectangular, as wide as head (length 1.0-1.14, width 2.10-2.40 mm); anterior margin broadly incurved, without notch; posterior

margin straight, sometimes with a weak incurving medially; sides round, antero-lateral corners sharp. Legs short, slender; apical tibial spurs 3:3:3; tarsi 4-jointed. Abdomen elongate, each tergum with a row of hairs at posterior margin; styli (in male) single-jointed; cerci 2-jointed.

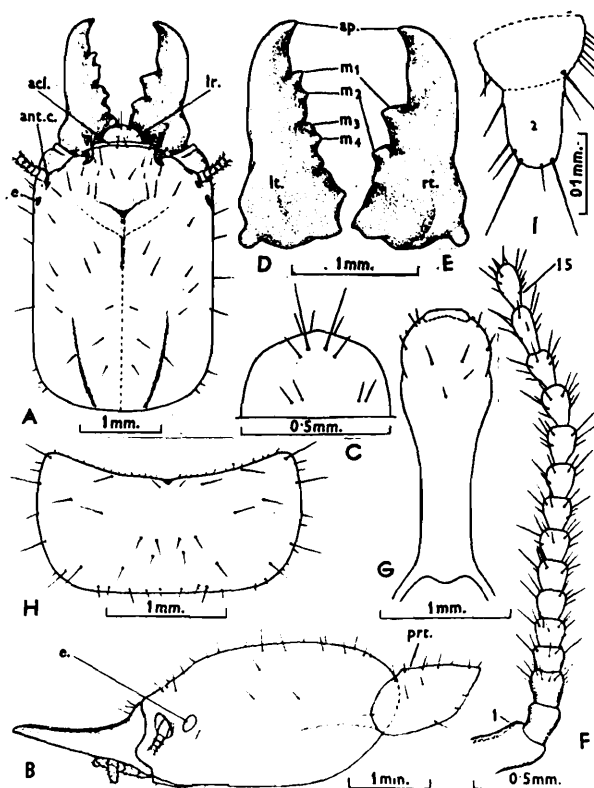

Fig. 137. *Neotermea mangiferae*. Soldier. (A) Head, in dorsal view. (B) Head and pronotum, in side view. (C) Labrum. (D) Left mandible. (E) Right mandible. (F) Right antenna. (G) Postmentum, in ventral view. (H) Pronotum, in dorsal view. (I) Left cercus. Lettering same as in fig. 109. (After Roonwal and Sen-Sarma, 1960).

**PSEUDOWORKER** : Head straw-coloured; labrum slightly darker sometimes; body yellowish white. Total length c 8.0-9.0 mm. Head-capsule squarish; width 1.90-2.0 mm. Eyes and ocelli absent. Antennae with 14 segments; segment 2 longer than 3; 3 subequal to 4 + 5. Postclypeus darker than frons; anteclypeus whitish, trapezoidal, longer than postclypeus. Labrum subsquarish; broader anteriorly, narrow basally; with a few hairs near tip. Mandibles typically *Neotermea*-type. Pronotum subrectangular, as wide as head (length 1.0-1.1, width 2.0-2.1 mm), anterior margin concave; sides sloping behind; posterior margin straight. Legs and abdomen as in soldier; hairs on abdomen sparse and not as prominent.

**Distribution** : INDIA : Eastern India (West Bengal); Tripura.

## 26. *Neotermes megaoculatus* Roonwal and Sen-Sarma

### 26a. *Neotermes megaoculatus megaoculatus* Roonwal and Sen-Sarma (Figs. 138, 139)

*Neotermes megaoculatus megaoculatus* Roonwal and Sen-Sarma :

1960. Roonwal and Sen-Sarma, *Contrib. Syst. Oriental Termites* (ICAR Ent. Monogr. <sup>1</sup>): 139, 143, 214-217, 271, 380-381 (Pl. 52). S, Pw. Holotype : S, in FRI, Dehra Dun. Type-locality : Dehradun, India. Types examined.
1962. Roonwal, *Termites in Humid Tropics* (New Delhi Symp. 1960 Proc.) : 40.
1967. Roonwal and Chhotani, *J. Bombay nat. Hist. Soc.*, 63(2): 362.
1975. Sen-Sarma et al., *Wood Destroying Termites (Final Tech. Rept. PL 480 Proj.)*: 64.
1978. Thakur, *J. Bombay nat. Hist. Soc.*, 75(1): 143-147.
1975. Chhotani, *Zool. Anz.*, 194 (1/2): 17.
1980. Sen-Sarma and Thakur, *Indian For. Rec. (N.S.) Ent.*, 14(1): 3-5.
1982. Grassé, *Termitologia* Vol. 1: 31.

**IMAGO (Fig. 138) :** Head-capsule and postclypeus pale to deep brown; antennae, labrum and pronotum brown; body brownish yellow; head and pronotum sparsely pilose. Total length with wings c 19.35-20.40, without wings c 10.00-11.90 mm. Head-capsule suboval, slightly broader than long (width 1.95-2.15, length to base of mandibles 1.75-1.90 mm); sides gradually converging to rounded posterior margin; frons weakly sloping in front; Y-suture distinct. Eyes large, subcircular (max. diameter 0.65-0.73, min. diameter 0.63-0.70 mm); separated from antennae by a distance of about 0.05 mm. Ocelli translucent, large, oval (maximum diameter 0.25-0.30, minimum diameter 0.20-0.23 mm); broadly touching ocular sclerites. Antennae with 18-19 segments, segment 2 much longer than 3, 3 longer than 4, 4 and 5 subequal. Clypeus trapezoidal. Labrum tongue-shaped, pilose; anterior margin rounded. Mandibles of *Neotermes*-type. Pronotum subrectangular, broader than head-width with eyes (width 2.00-2.20, length 1.05-1.20 mm); anterior margin broadly concave, posterior margin substraight. Legs slender, tibial spurs 3:3:3; tarsi 4-jointed. Wing-membrane not pigmented in distal half, weakly tuberculate. Forewing : Length 16.00-17.30 mm. Venation in general as in genus; subcosta fusing with costa near proximal third of wing-membrane; radius unbranched, meeting costa at nearly half of wing-membrane; radial sector with 7-8 branches to costa; media with 5-7 short branches to radial sector; cubitus

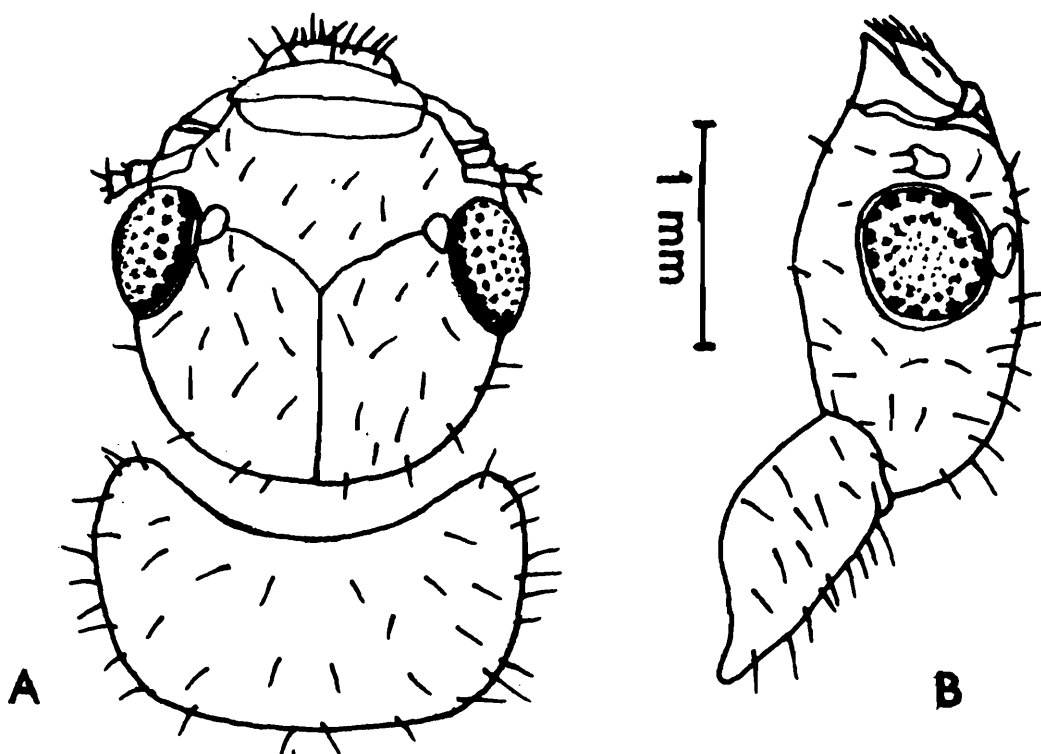

Fig. 138. *Neotermes megaoculatus megaoculatus*. Imago. (A) Head and pronotum, in dorsal view (B) Head and pronotum, in side view.

(Redrawn from Thakur, 1978)

with 12-15 branches. Hindwing : Length 14.0-16.0 mm. Radius meeting costa a little beyond half of wing membrane; radial sector with 5-7 branches to costa in distal half; media arising from radial sector at about  $1/5$  of length of wing; cubitus with 11-14 branches. Abdomen elongate, pilose; cerci 2-segmented.

**SOLDIER (Fig. 139) :** Head-capsule brown to dark brown; antennae basally pale brown, paler distally, 3rd segment dark brown; labrum brownish, mandibles basally dark brown, apically blackish; pronotum and legs straw-coloured, body whitish. Head-capsule subrectangular, length of head to base of mandibles about  $2/3$ rd of width (length 3.60-4.50, width 2.60-2.88 mm); sides subparallel; frons sloping anteriorly and with a median depression extending backwards upto middle of head or a little beyond; Y-suture indistinct. Eyes, large oval, whitish (max. diameter 0.30-0.42 mm); minimum eye-antennal distance equal to diameter. Ocelli absent. Antennae with 14-16 segments, pilose; segment 3 subequal to 2, 4 shortest. Postclypeus darker than frons, subrectangular, with 2 pairs of hairs at anterior margin; anteclypeus weakly developed. Labrum, small to large, much wider than long (length 0.36-0.42, width 0.60-0.78 mm); sides

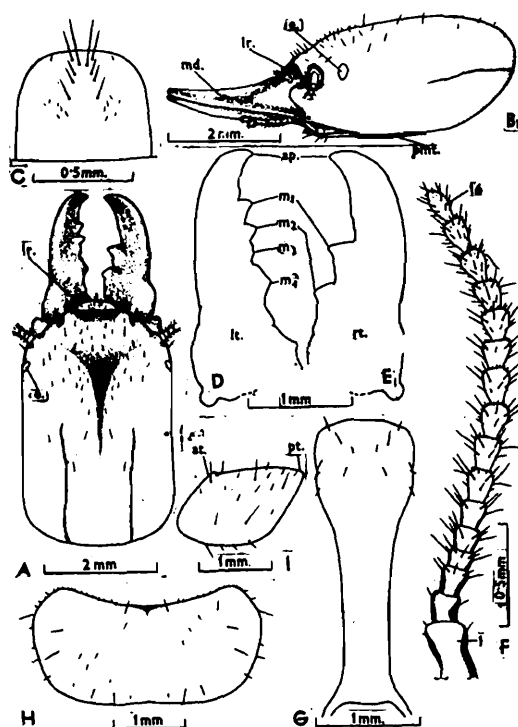

Fig. 139. *Neotermes megaoculatus megaoculatus*. Soldier. (A) Head, in dorsal view. (B) Head, in side view. (C) Labrum. (D) Left mandible. (E) Right mandible. (F) Right antenna. (G) Postmentum. (H) Pronotum, in dorsal view. (I) Same, in side view. Lettering same as in fig. 109. (After Roonwal and Sen-Sarma 1960).

subparallel, anterior margin convex, with a few hairs on tip and body. Mandibles strong, stout, basally weakly humped; length more than half of head-length to base of mandibles (length 2.00-2.76 mm, Mandible-length/Head-length index 0.50-0.65); left mandible with 3-5 small to large teeth; right with 2 large, triangular marginal teeth. Postmentum long (length 2.76-3.36 mm), club bilobed forming fore and hind lobes; anterior lobe more swollen, maximum width 0.90-1.02 mm; stalk narrow, minimum width at waist 0.30-0.43 mm. Pronotum subrectangular, sparsely pilose; as wide as or a little wider than head; width 2.46-3.0, length 1.10-1.62 mm; anterior margin broadly concave, without median notch and posterior margin substraight. Legs slender, sparsely pilose; apical tibial spurs 3:3:3; tarsi 4-segmented. Abdomen, elongate; each tergum with 2 rows of hairs; cerci short, 2-jointed, hairy.

**PSEUDOWORKER** : Head-capsule, labrum and basal part of mandibles straw-coloured, mandibular toothed margins dark brown; antennae legs and body yellowish white. Head and body sparsely pilose. Total length c 7.5-9.5 mm. Head-capsule subcircular, width a little more than length of

head to mandible-base (length 2.0-2.20, width 2.1-2.30 mm). Eyes rudimentary, circular, white spots. Ocelli absent. Antennae with 15-16 segments; segments 2 and 3, and 4 and 5 subequal. Postclypeus rectangular, darker than frons; with a few hairs at anterior margin; anteclypeus trapezoidal, whitish. Labrum subcircular, with a few hairs on body and tip, anterior margin rounded. Mandibles of typical *Neotermes*-type. Pronotum subrectangular, sparsely pilose; almost as wide as head; length 1.1-1.3, width 2.1-2.5 mm; anterior margin deeply concave, not medially notched; posterior margin substraight. Legs slender, pilose, tibial spurs 3:3:3; tarsi 4-jointed. Abdomen elongate; with a row of long, sparse hairs on each tergum; cerci short, 2-jointed, hairy.

*Distribution* : INDIA . Uttar Pradesh : Dehra Dun, type-locality and Kanda.

**26b. *Neotermes megaoculatus lakhimpuri* Roonwal and Sen-Sarma  
(Fig. 140)**

*Neotermes megaoculatus lakhimpuri* Roonwal and Sen-Sarma :

1960. Roonwal and Sen-Sarma, *Contrib. Syst. Oriental Termites* (ICAR Ent. Monogr. 1): 139, 143, 217-220, 271. S, Pw. Holotype : S, in FRI, Dehra Dun. Type-locality : Makum, Lakhimpur (Assam, India). Type examined.
1962. Roonwal and Chhotani, *Proc. natnl. Inst. Sci. India*, (B) 28(4).
1962. Roonwal, In *Termites in Humid Tropics* (New Delhi Symp. 1960 Proc.): 40.
1967. Roonwal and Chhotani, *J. Bombay nat. Hist. Soc.*, 63(2): 362.
1965. Sen-Sarma et al., *Wood Destroying Termites (Final Tech. Rept. PL 480 Proj.)*: 10, 35, 51, 64.
1975. Chhotani, *Zool. Anz.*, 194 (1/2) : 17.

**IMAGO : Unknown.**

**SOLDIER (Fig. 140) :** It is fairly close to that of *Neotermes megaoculatus megaoculatus* R. & S., but differs from it as follows : (1) It has a larger head (head-length to base of mandibles 4.1-5.0 vs. 3.87-4.50 mm in *m. megaoculatus*). (2) Mandibles shorter absolutely (2.00-2.20 vs. 2.10-2.76 mm) and in relation to head-length to base of mandibles (generally less than half of head-length, index Mandible-length/Head-length to base of mandibles 0.42-0.54 usually 0.42-0.47; in *m. megaoculatus* mandibles more

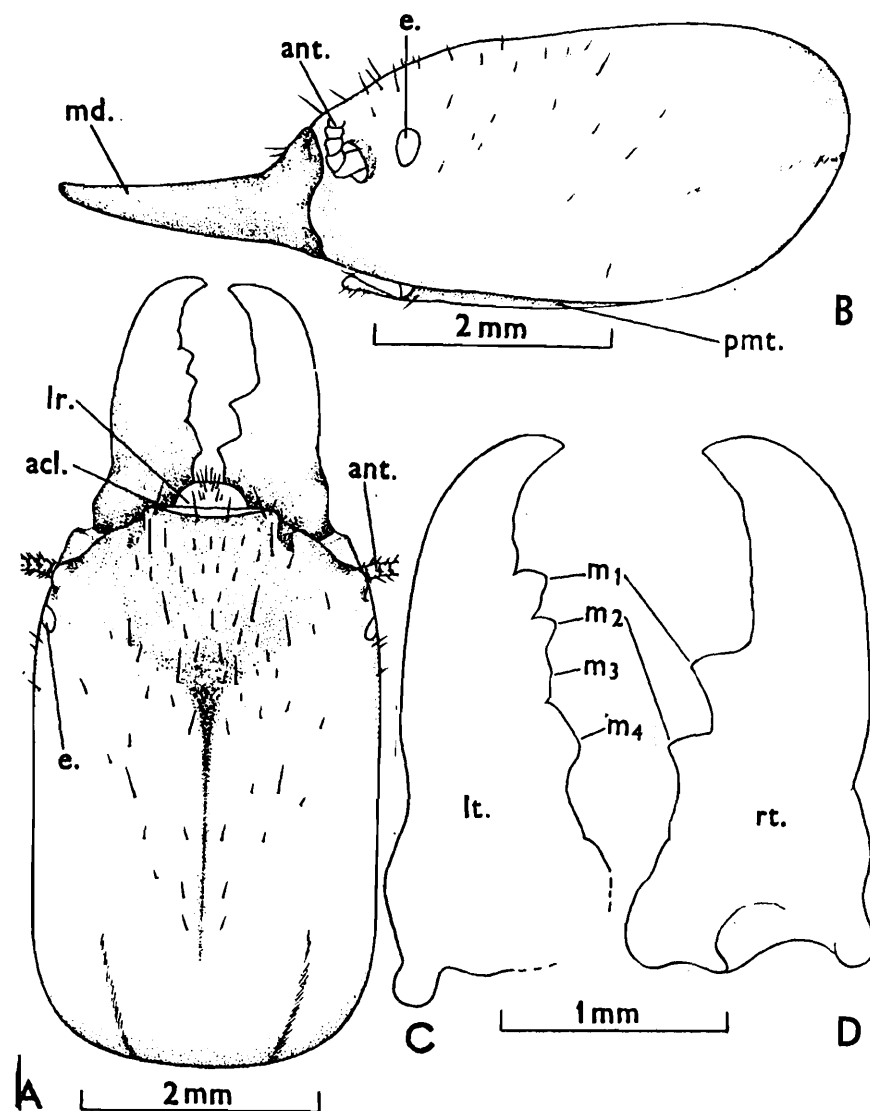

Fig. 140. *Neotermes megaoculatus lakhimpuri*. Soldier. (A) Head, in dorsal view. (B) Same, in side view. (C) Left mandible. (D) Right mandible. Lettering same as in fig. 109. (After Roonwal and Sarma, 1960).

than half of head-length, head-mandibular length index, 0.50-0.65, mostly 0.55-0.65). (3) Antennae 16-17 segmented vs. 14-16 segmented.

**PSEUDOWORKER** : As in *m. megaoculatus* R. & S. but labrum better developed in *m. lakhimpuri*. Total length 7.0-8.5, head-length to base of mandibles 2.0-2.3, head-width 2.1-2.3, pronotum-length 1.1-1.3 and pronotum-width 2.1-2.3.

**Distribution** : INDIA : Makum (Lakhimpur), type-locality.

**27. *Neotermes microculatus* Roonwal and Sen-Sarma  
(Fig. 141)**

*Neotermes microculatus* Roonwal and Sen-Sarma :

1960. Roonwal and Sen-Sarma, *Contrib. Syst. Oriental Termites* (ICAR Ent. Monogr. 1) : 139, 142, 220-223, 270, 382-383 (Pl. 53). S, Pw. Holotype : S, in FRI, Dehra Dun. Type-locality : Dehra Dun (Uttar Pradesh, India). Type examined.
1962. Roonwal, *Termites in Humid Tropics* (Proc. New Delhi Symp., 1960): 40.
1967. Roonwal and Chhotani, *J. Bombay nat. Hist. Soc.*, 63(2): 362.
1975. Chhotani, *Zool. Anz.*, 194 (1/2): 118.

**SOLDIER (Fig. 141) :** Head-capsule and mandibles reddish brown; antennae basally brown, distally paler; mandibles blackish, reddish brown basally; labrum pale brown; pronotum, legs and body yellowish white; head and body sparsely pilose. Total body-length c 10.7 mm. Head-capsule rectangular, length about one-and-a-half times of width; length of head to base of mandibles 3.2-3.3, width of head 2.10-2.2 mm; sides subparallel, frons sloping in front, medially depressed upto middle or little beyond; Y-suture not visible. Eyes whitish, flat, suboval (max. diameter 0.10-0.15, min. diameter 0.05-0.075 mm); minimum eye-antennal distance one-and-a-half times of maximum diameter of eye. Ocelli absent. Antennae with 14 segments; segment 3 longer or subequal to 2; 4 shortest. Postclypeus flat, rectangular, darker than frons; with 2 pairs of long hairs at anterior margin; anteclypeus narrow, whitish, trapezoidal. Labrum squarish (width 0.50-0.55, length 0.30-0.40 mm); with a few short and long hairs at tip and on body. Mandibles long and stout, 1.70-1.80 mm long; almost straight but with weak outward hump at base; apices slightly bent inwards; length a little more than 1/2 of head length to mandible - base (Mandible length/Head-length index 0.53-0.55). Left mandible with 5 prominent, marginal teeth. Right with 2 large, subequal marginals. Postmentum long, club-shaped; club, subsquarish, indistinctly bilobed into subequal anterior and posterior halves, thence gradually narrowing posteriorly to a long waist; length 2.60-2.80, max. width at club 0.75-0.80, min. width at waist 0.30-0.35 mm. Pronotum subrectangular (width 2.10, length 0.90-1.10 mm); width subequal to head-width; sparsely pilose; anterior margin shallowly concave, without a median notch; posterior margin straight with faint median incurving. Legs slender, elongate; tibial spurs 3:3:3; tarsi 4-segmented. Abdomen elongate, each tergum with a row of sparse hairs; cerci short, hairy, 2-segmented.

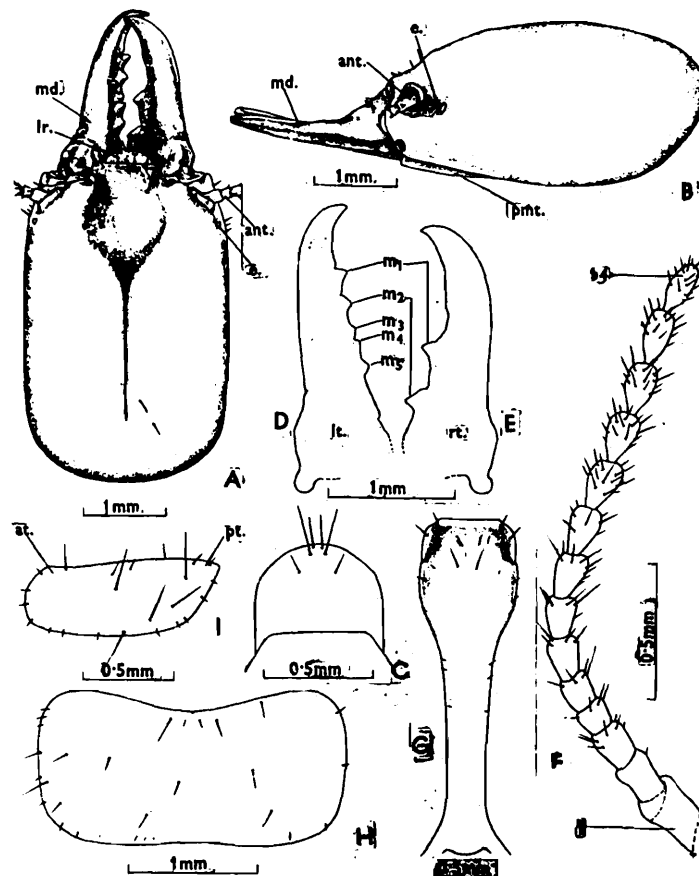

Fig. 141. *Neotermes microculatus*. Soldier. (A) Head, in dorsal view. (B) Same, in side view. (C) Labrum. (D) Left mandible. (E) Right mandible. (F) Left antenna. (G) Postmentum. (H) Pronotum, in dorsal view. (I) Same, in side view. Lettering same as in fig. 109. (After Roonwal and Sen-Sarma, 1960).

**PSEUDOWORKER** : Head-capsule straw-coloured; antennae, body and legs whitish, head and body moderately pilose. Total body-length c 5.6-7.3 mm. Head-capsule subround (length to base of mandibles 1.4-1.7, width 1.6-1.9 mm); with a few long and many short hairs. Eyes rudimentary, present as faint, whitish impressions. Antennae with 13-14 segments; segment 2 longer than 3; 3, 4, 5, subequal. Postclypeus rectangular and darker than frons, with 2 pairs of hairs at anterior margin; anteclypeus whitish, trapezoidal. Labrum subsquarish, with a few hairs on tip and body; anterior margin rounded. Mandibles of typical *Neotermes*-type. Pronotum subrectangular (length 0.8-1.0, width 1.6-1.9 mm); fairly hairy; anterior margin concave, without notch; posterior margin substraight, with shallow incurving. Legs and abdomen as in soldier.

**Distribution** : INDIA : Uttar Pradesh : Dehra Dun, type-locality.

28. *Neotermes nilamburensis* Thakur  
(Figs. 142, 143)

*Neotermes nilamburensis* Thakur :

1978. Thakur *J. Indian Acad. Wood. Sci.*, 9(1): 56-61. Holotype. S, in FRI. Type-locality : Nilambur (Kerala), India. Type examined.

1984. Bose, *Occ. Pap. Rec. zool. Surv. India*, No. 49: 22, 45-47.

**IMAGO** (Fig. 142) Head-capsule yellowish brown to deep reddish brown; pronotum brown to deep brown; antennae and legs yellowish; body yellowish white. Head and pronotum sparsely and body fairly, pilose. Total length without wings c 8.60-9.75, with wings c 15.50-17.30 mm. Head-capsule subsquarish; (length of head to base of mandibles 1.50-1.65, width 1.55-1.75 mm), posteriorly rounded; with long hairs; Y-suture distinct; frons gently sloping in front. Eyes subcircular (max. diameter 0.50-0.58, min. diameter 0.48-0.55 mm); lying very close to antennal sockets, eye-antennal distance 0.03-0.05 mm. Ocelli large, oval (max. diameter 0.20-0.25, min. diameter 0.13-0.18 mm); broadly touching eyes. Antennae with 17-18 segments; segment 3 subequal to or shorter than 2, 4 shortest. Postclypeus subrectangular, darker than frons; anteclypeus whitish, trapezoidal. Labrum tongue-shaped, anterior margin convex. Mandibles of *Neotermes*-type.

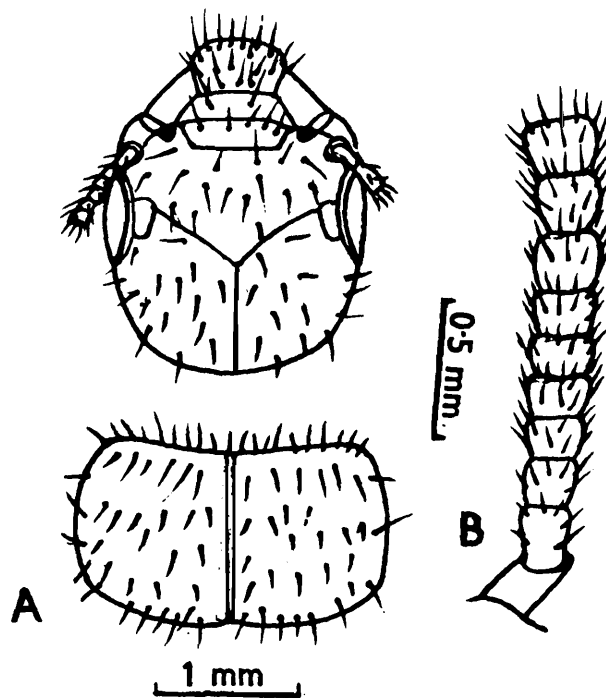

Fig. 142. *Neotermes nilamburensis*. Imago. (A) Head and pronotum, in dorsal view. (B) Antenna (Redrawn from Thakur, 1978a).

Pronotum flat, subrectangular, sides rounded (length 1.00-1.05, width 1.68-1.88 mm); slightly broader than head-width with eyes; anterior margin broadly concave and posterior margin weakly invaginated. Legs with weakly swollen femora; tibiae elongate, tibial spurs 3:3:3; tarsi 4-jointed. Wing-membranes non-pigmented, weakly tuberculate. Forewing 14.00-15.2 mm long; subcosta prominent, joining costa at proximal 1/8th of wing; radius meeting costa at about half of wing; radial sector with 5-7 branches to costa; media with upto 4 transverse branches to radial sector; cubitus well-marked, proximal veins pigmented, with 18-20 main branches. Hindwing 12.2-12.4 mm long; radius joining with costa little beyond middle of wing; media arising from radial sector a little before middle of wing-membrane; cubitus with 15-18 branches. Abdomen elongate, cerci 2-segmented.

**SOLDIER (Fig. 143)** Head-capsule yellowish brown to deep reddish brown; antennae basally deep brown, apically darker mandibles, basally deep reddish brown, apically blackish; pronotum paler than head-capsule; abdomen yellowish. Head and pronotum sparsely and body fairly, pilose. Total length 10.00-11.90 mm. Head-capsule subrectangular (head-length to base of mandibles 3.20-3.50, head-width 2.0-2.18 mm); sides subparallel, head-dorsum flat; Y-suture distinct; frons gently sloping in front. Eyes large, oblong (max. diameter 0.18-0.38, min. diameter 0.10-0.25 mm); eye-antennal distance 0.13-0.23 mm. Ocelli absent. Antennae with 12-15 segments; segment 3 longer than 2; 4 shortest. Postclypeus subrectangular; anteclypeus trapezoidal, whitish. Labrum subsquarish, with a few hairs on anterior margin and on body. Mandibles short, robust, little longer than half of head-length to base of mandibles (length 1.70-1.95 mm, Mandible-length/Head-length index 0.50-0.57); basal humps prominent, apices weakly incurved. Left mandible with 5 and right with 2 marginal teeth. Postmentum club-shaped, long (length 2.20-2.55 mm); anterior part broadest (max. width 0.73-0.85 mm); narrowing posteriorly to a long waist (minimum width at waist 0.28-0.43 mm) and again widening out at base; anterior margin substraight. Pronotum subrectangular, as wide as head-width (width 1.95-2.25, length 1.05-1.20 mm, Pronotum-width/Head width index 0.95-1.04); anterior margin concave with distinct median notch, posterior margin substraight. Legs short, slender; apical tibial spurs 3:3:3; tarsi 4-jointed. Abdomen ovate, cerci 2-segmented, styli single-jointed.

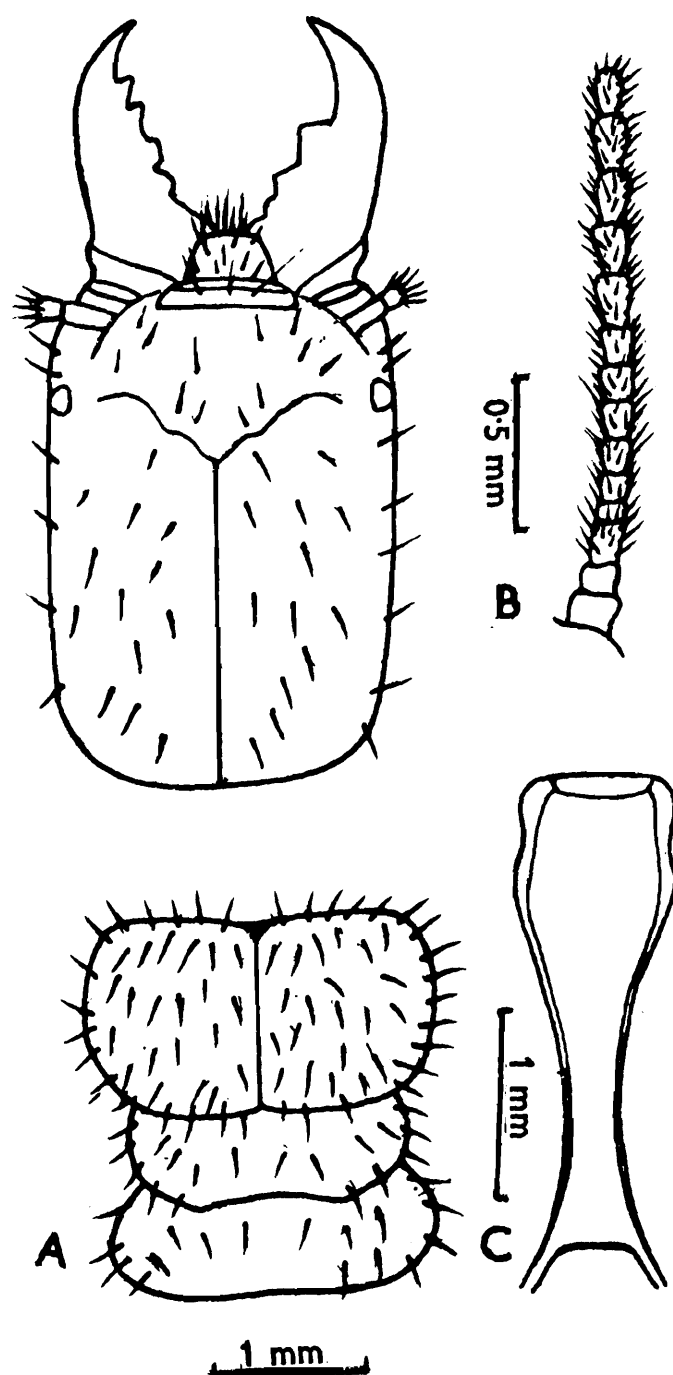

Fig. 143. *Neotermes nilamburensis*. Soldier. (A) Head and thorax, in dorsal view. (B) Antenna. (C) Postmentum. (Redrawn from Thakur, 1978a).

**PSEUDOWORKER** Head-capsule pale; postclypeus pale to deep straw-coloured; labrum and rest of body paler. Head and pronotum sparsely and body fairly pilose. Total length c 7.20-8.30 mm. Head-capsule subrounded (length to mandible-base 1.45-1.75, head-width 1.65-1.78 mm); Y-suture not visible. Eyes flush with head surface, whitish, small; maximum diameter 0.18-0.23, min. diameter 0.13-0.15 mm. Ocelli absent. Antennae short,

with 14-18 segments, segment 2 longer than 3, 4 shortest. Postclypeus flat; anteclypeus whitish, trapezoidal. Labrum dome-shaped. Mandibles of *Neotermes*-type. Pronotum subrectangular (width 1.70-1.85, length 0.85-1.00 mm); anterior margin concave, posterior substraight. Legs short, apical spurs 3:3:3; tarsi 4-jointed. Abdomen elongate; cerci 2-segmented; styli single jointed.

*Distribution* INDIA Kerala Nilambur, known only from the type-locality.

### 29. *Neotermes paratensis* Sen-Sarma and Thakur (Figs. 144, 145)

*Neotermes paratensis* Sen-Sarma and Thakur :

1975. Sen-Sarma and Thakur, In Sen-Sarma, Thakur, Misra and Gupta, *Wood Destroying Termites of India (Final Tech. Rep. Pl. 480 Proj. A7-FS-58)* : 10, 51. (Included in key only, authorship assigned to Sen-Sarma and Thakur).

1979. Sen-Sarma and Thakur, *Indian For. Rec. (N.S.)*, 13(1): 6-9. Im, S, Pw. Holotype : S, in FRI, Dehra Dun. Type-locality : Paratia (Tripura, India).

IMAGO (Fig. 144) : Head-capsule, pronotum and wing scales dark reddish, abdominal tergites paler; antennae, labrum, legs and abdominal sternites deep yellowish brown. Head and pronotum sparsely and body fairly, pilose. Total length without wings c 7.55-8.55 mm. Head-capsule subsquarish (length to base of mandibles 1.50-1.70, width with eyes 1.80-1.88 mm); sides subparallel; posterior margin rounded; Y-suture distinct. Eyes subcircular (max. diameter 0.60-0.63, min. diameter 0.58 mm); lying very close to antennal sockets. Ocelli large, oval (max. diameter 0.23-0.25, min. diameter 0.15-0.20 mm), whitish and translucent; touching eyes. Antennae ? segmented; segment 2 longer than 3; 4 shortest. Postclypeus flat, subrectangular, with a few hairs, anterior margin weakly convex; anteclypeus yellowish white, trapezoidal, apilose. Labrum subsquarish, sides weakly arched, tip and body pilose. Mandibles *Neotermes*-type. Pronotum subrectangular, sparsely pilose; wider than head with eyes, (width 1.88-2.10, length 1.13-1.15 mm); anterior margin broadly concave; posterior margin with a weak medial emargination. Legs short, femora slightly swollen, tibial spurs 3:3:3; tarsi 4-jointed. Abdomen oblong, pilose; cerci 2-segmented.

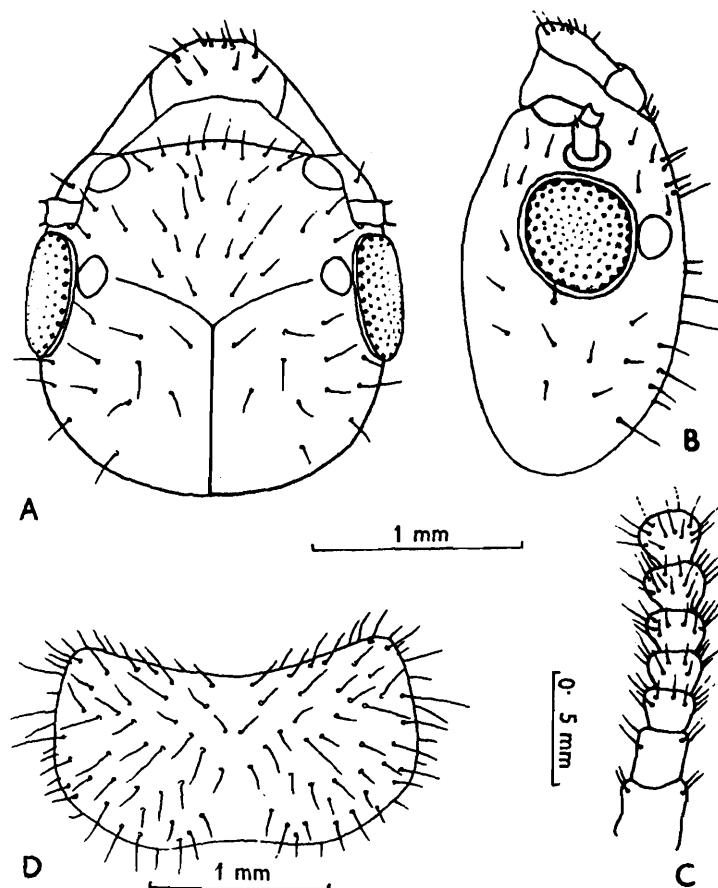

Fig. 144. *Neotermes paratensis*. Imago. (A) Head, in dorsal view. (B) Head in side view. (C) Basal part of antenna. (D) Pronotum, in dorsal view. (Redrawn from Sen Sarma and Thakur, 1979).

**SOLDIER** (Fig. 145) Head capsule golden reddish brown, darker anteriorly; antennae and labrum basally, rusty brown, apically paler; mandibles basally deep reddish brown otherwise blackish; legs and body yellowish white. Head and pronotum moderately and body fairly, pilose. Total length 9.03-9.15 mm. Head-capsule subrectangular, much longer than broad (length to base of mandibles 2.90-3.20, width 1.94-2.05 mm), sides subparallel narrowing slightly to rounded posterior margin; frons gently sloping anteriorly at about  $45^\circ$  angle; Y-suture distinct. Eyes oval, 0.20 mm long, translucent. Antennae with 13-14 segments; segment 2 narrower, but subequal to 3; 4 shortest. Postclypeus subrectangular, with 4-5 hairs on anterior margin; anteclypeus trapezoidal, whitish, apilose. Labrum subrectangular, broader than long; anterior margin rounded; tip and body pilose. Mandibles short, stout; 1.73-1.83 mm long; longer than half of head-length, index Mandible-length/Head-length 0.55-0.60; left mandible

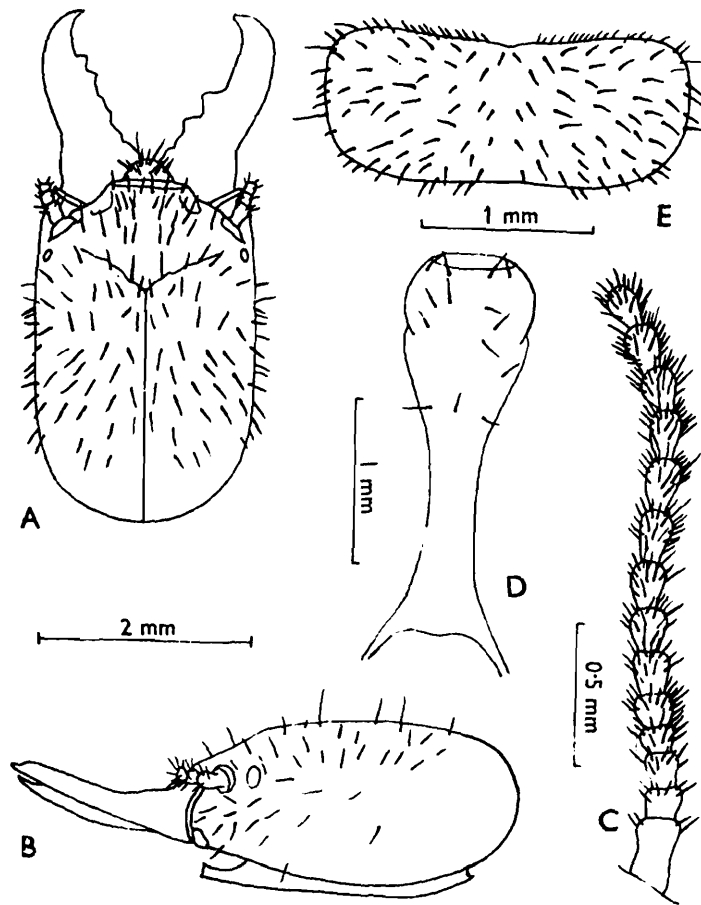

Fig. 145. *Neotermes paratensis*. Soldier. (A) Head, in dorsal view (B) Head, in side view. (C) Antenna. (D) Postmentum. (E) Pronotum, in dorsal view. (Redrawn from Sen-Sarma and Thakur, 1979).

with thinner strongly incurved apex and 5 marginal teeth (2 large triangular and 3 low, smaller); right mandible with thicker incurved apex and 2 large triangular marginal teeth. Postmentum long (2.30-2.40 mm), club-shaped and broadest (0.73-0.80 mm) anteriorly; club bilobed; sharply narrowing behind to a long waist (width at waist 0.30-0.33 mm) and widening out at base. Pronotum subrectangular, much wider than long (width 1.94-2.05, length 0.85-0.95 mm); as wide as head; anterior margin weakly concave, without notch; posterior margin substraight. Legs short, slender, pilose; tibial spurs 3:3:3; tarsi 4-jointed. Abdomen elongate, oval; cerci 2-segmented, short, hairy.

**PSEUDOWORKER** : Head-capsule pale yellow, frons paler; antennae and postclypeus yellowish; labrum and mandibles basally brownish yellow;

pronotum sparsely and body fairly, pilose. Total-length 5.50-6.95 mm. Head-capsule subsquarish (length to base of mandibles 1.30-1.45, width 1.35-1.60 mm), widest at base of antennae, sides gradually converging to a broadly rounded posterior margin; Y-suture indistinct. Eyes visible only in strong light, vestigial, small, oval, flush with head surface. Antennae with 12-13 segments; segment 2 longer than 3; segment 4 shortest. Postclypeus rectangular with a few hairs on anterior margin; anteclypeus trapezoidal, apilose. Labrum dome-shaped, sparsely pilose. Mandibles of *Neotermes*-type. Pronotum flat, subrectangular (length 0.48-0.70, width 1.20-1.65 mm); anterior margin broadly concave, posterior margin substraight. Legs short, slender, tibial spurs 3:3:3; tarsi 4-jointed. Abdomen oblong, pilose; cerci 2-segmented.

*Distribution* : INDIA Tripura : Paratia, known only from type-locality.

### 30. *Neotermes prosonneratae* Akhtar

(Figs. 146, 147)

1975. *Neotermes prosonneratae* Akhtar, *Bull. Dept. Zool. Univ. Panjab*, (N.S.), Art. 7: 11-15. Im, S. Holotype : S, in Zool. Dept., Panjab Univ., Lahore. Type-locality: Dariadighi, Bangladesh.

IMAGO (Fig. 146) : Head-capsule reddish brown; frons, postclypeus, labrum and antennae apically, yellowish brown; pronotum and wings light brown; legs paler. Head sparsely and pronotum fairly pilose; wings with short hairs along costal margin. Head-capsule subsquarish (length to base of mandibles 1.65-1.70, width with eyes 1.80-1.86 mm); posterior margin rounded; frons sloping gently in front; Y-suture distinct, with a Y-shaped depression above. Eyes subcircular, truncated anteriorly (max. diameter 0.57-0.61, min. diameter 0.52-0.57 mm); eye-antennal distance 0.50 mm. Ocelli prominent, touching eyes, suboval (length 0.23-0.25, width 0.18-0.20 mm). Antennae with 17-19 segments; segment 3 shortest; 4 and 5 subequal. Mandibles of *Neotermes*-type; left and right mandibles each with 2 marginal teeth. Postclypeus not differentiated from frons, with a few hairs on anterior margin; anteclypeus trapezoidal. Labrum broader than long, anterior margin weakly concave; with hairs on anterior margin and on body. Pronotum pilose, subrectangular, broader than head with eyes (length

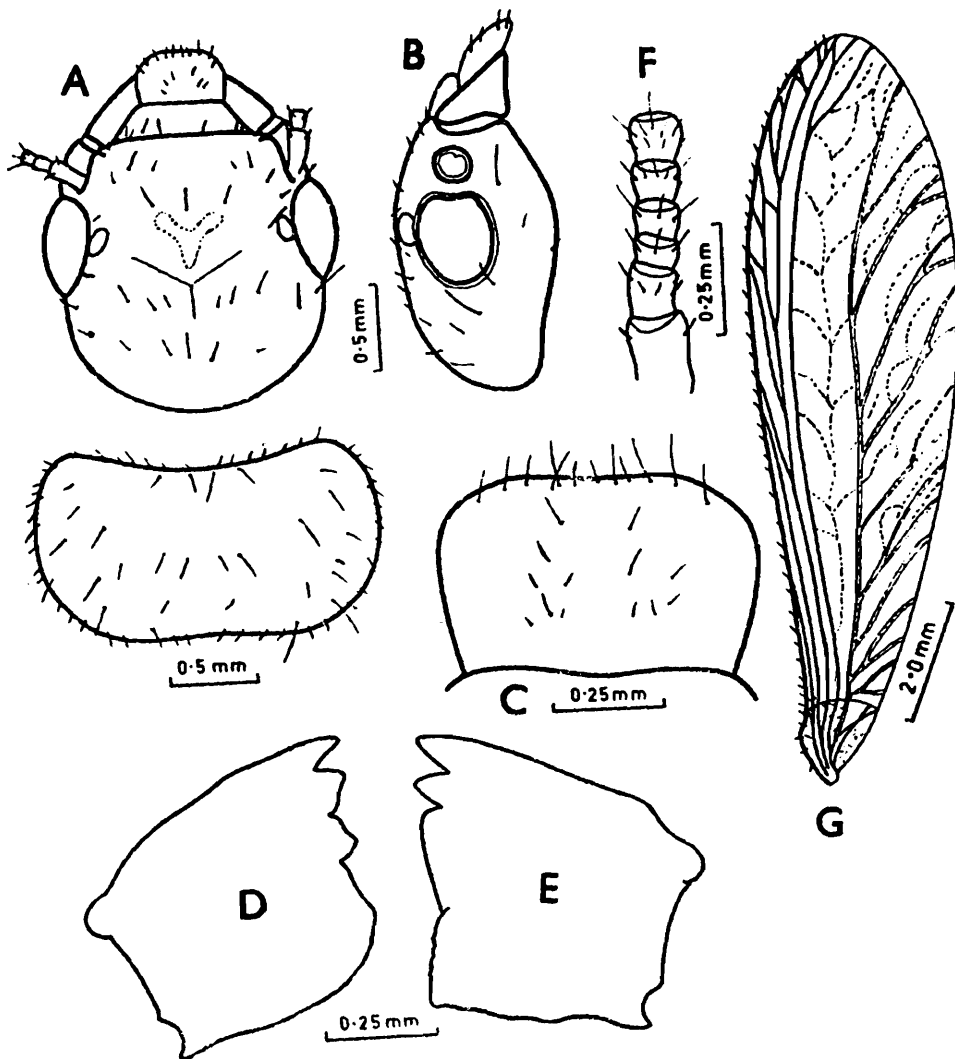

Fig. 146. *Neotermes prosonneratae*. Imago. (A) Head and pronotum, in dorsal view. (B) Head, in side view. (C) Labrum. (D) and (E) Left and right mandibles. (F) basal part of antenna. (G) Right forewing. (After Akhtar, 1975).

0.95-1.08, width 1.93-2.15 mm); anterior margin deeply concave, posterior -one substraight with weak median depression. Legs with apical tibial spurs 3:3:3. Forewings with all major veins arising independently at wing suture, media as strongly sclerotized as radial sector and running close to it; cubitus weak, unsclerotized.

**SOLDIER (Fig. 147) :** Head-capsule and antennae basally light reddish brown, frons and postclypeus darker, anteclypeus whitish; labrum light brown; mandibles basally reddish brown, rest blackish; pronotum and abdomen brownish yellow; legs pale. Head and body sparsely pilose.

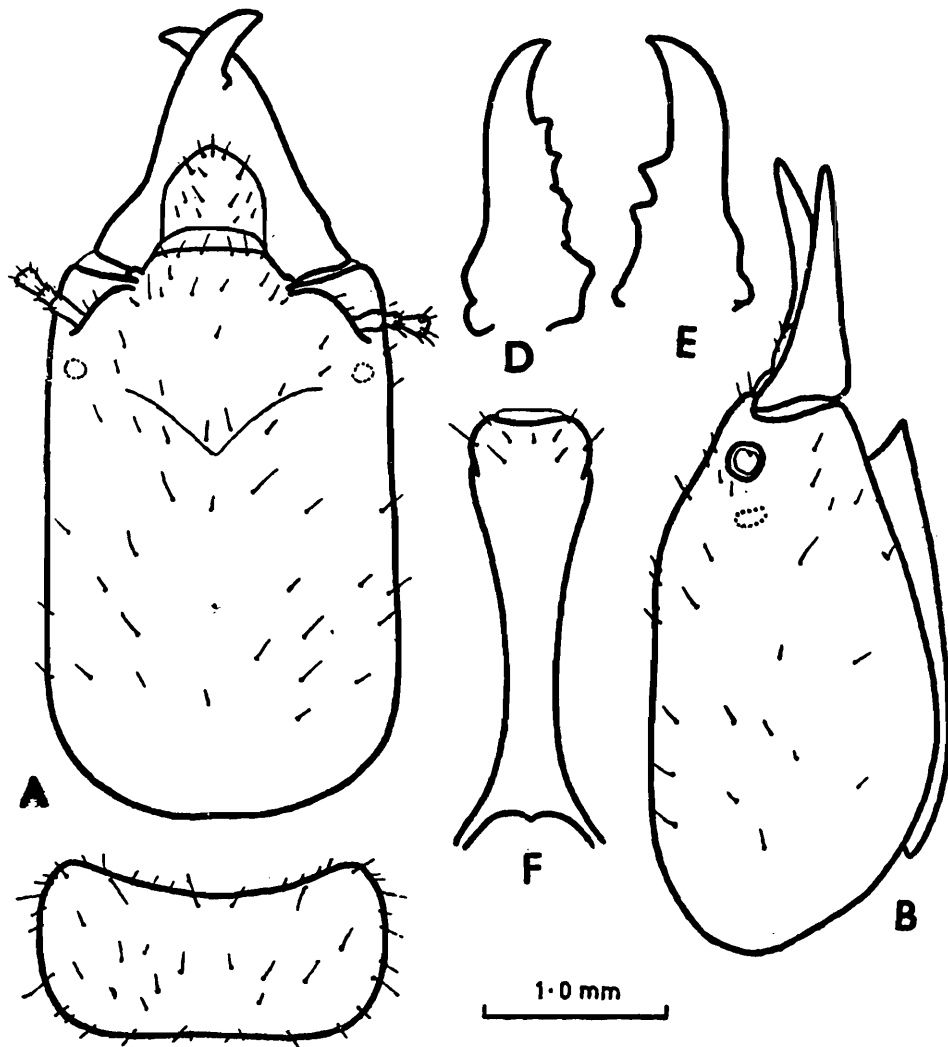

Fig. 147. *Neotermes prosonneratae*. Soldier. (A) Head and pronotum, in dorsal view. (B) Head, in side view. (C) and (D) Left and right mandibles. (E) Postmentum. (After Akhtar, 1975).

Head-capsule subrectangular (length to base of mandibles 3.27-3.64, width 2.11-2.30 mm); sides subparallel; frons sloping in front, with a medial depression; Y-suture indistinctly present. Eyes oval (max. diameter 0.17-0.22, min. diameter 0.10-0.12 mm); eye-antennal distance 0.20 mm. Antennae with 13-14 segments; segment 3 strongly sclerotized, longer than 2; 4 and 5 subequal. Postclypeus not well differentiated from frons, and with a few hairs on margin and on body; anteclypeus whitish, narrow, apilose. Labrum wider than long, sides subparallel, anteriorly tongue-shaped, with a few hairs on body and tip. Mandibles long, robust, with prominent basal humps; length of mandibles approximately half length of

head (Mandible length/Head length index 0.48-0.52); left mandible with 5 and right with 2, marginal teeth. Postmentum club-shaped, broadest at anterior end, narrowing posteriorly to a waist at about basal one-third; postmentum length 2.58-2.81, widest width 0.76-0.83, width at waist 0.30-0.37 mm; club bilobed. Pronotum broad (width 2.20-2.35 mm); slightly wider than head; anterior margin deeply concave, and without notch; posterior margin substraight. Apical tibial spurs 3:3:3.

*Distribution* : Bangladesh Cox's Bazar, Dariadighi and Teknaf.

### 31. *Neotermes shimogensis* Thakur

(Fig. 148)

*Neotermes shimogensis* Thakur :

1975. Sen-Sarma and Thakur, In Sen-Sarma, Thakur, Misra and Gupta, *Wood Destroying Termites of India (Final Tech. Rep. PL. 480 Proj. A7-FS-58)*: 10-51.

(Included in key only, authorship assigned to Sen-Sarma and Thakur).

1980. Thakur, *Bull. Ent.*, 14(1973): 91-96. S, Pw. Holotype : S, in FRI, Dehra Dun. Type- locality: Shimoga, Karnataka, India.

IMAGO : Not known.

**SOLDIER** (Fig. 148) : Head-capsule golden brown, paler posteriorly; antennae brown, paler distally; mandibles blackish, deep reddish brown proximally; thorax and body yellowish brown. Head and pronotum sparsely and abdomen fairly, pilose. Total body-length c 10.0-11.20 mm. Head-capsule subrectangular; width about 3/4th of length or a little less (head-length to base of mandibles 3.30-3.60, width 2.45-2.60 mm, index Width/Length 0.70-0.75); sides subparallel; posterior margin rounded; frons sloping in front at about 45° angle and with a shallow, median depression; Y-suture distinct. Eyes oval, translucent, fairly large (length 0.30, width 0.175 mm). Ocelli minute, situated at ends of lateral arms of Y-suture. Antennae with 15-16 segments; carinae well developed; segment 3 longer than 2 and strongly sclerotised; 4 shortest. Postclypeus subrectangular with a pair of hairs on either side near anterior margin; anteclypeus trapezoidal, translucent, white. Mandibles short and stout, basally humped prominently at outer margin; a little longer than half of head-length (length 1.75-1.93 mm, index Mandible-length/Head-length 0.51-0.56). Left mandible with 5 marginal teeth, marginal 1 and 2 larger; and right with 2 large,

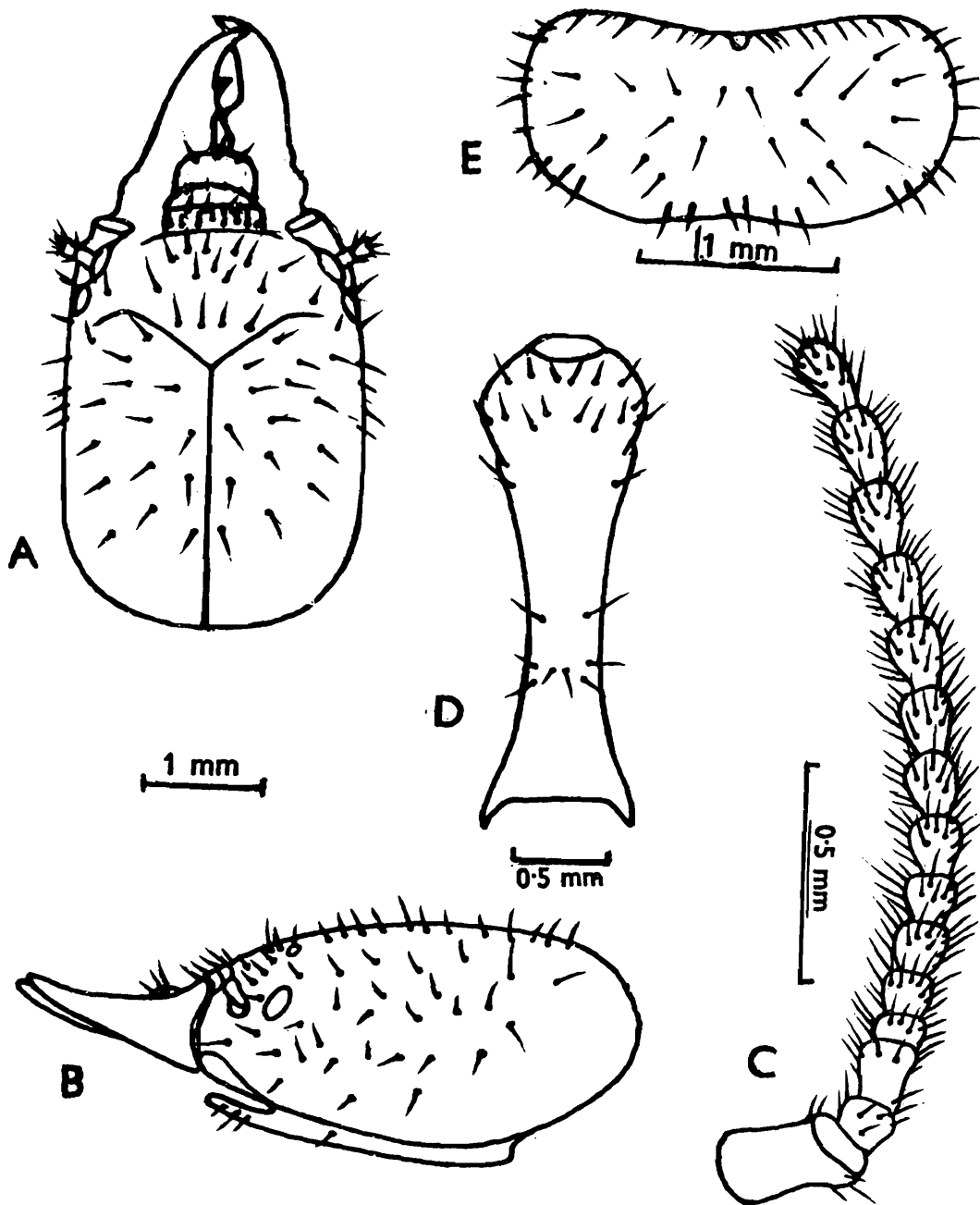

Fig. 148. *Neotermes shimogensis*. Soldier. (A) Head, in dorsal view (B) Same, in side view. (C) Antenna. (D) Postmentum. (E) Pronotum, in dorsal view. (Redrawn from Thakur, 1980c).

triangular, marginals lying medially. Postmentum long, club-shaped; club bilobed; stalk forming a long and fairly wide waist (length 2.3-2.5, max. width 0.75-0.80, width at waist 0.33-0.38 mm). Pronotum subrectangular, slightly narrower than head and a little more than twice as wide as long (length 1.0-1.15, width 2.23-2.35 mm); anterior margin weakly incurved;

sides rounded; posterior margin emarginate medially. Legs short, slender; apical tibial spurs 3:3:3; tarsi 4-jointed. Abdomen elongate; cylindrical; cerci 2-jointed.

**PSEUDOWORKER** Head-capsule pale yellow to yellow; thorax and abdomen creamish white. Head and body moderately hairy. Total body-length 6.5-8.0 mm. Head-capsule subcircular; sides somewhat straighter; wider than long (length to base of mandibles 1.40-1.50, width 1.63-1.70 mm). Eyes rudimentary, whitish. Antennae with 16-18 segments. Postclypeus subrectangular, darker than frons; anteclypeus white, trapezoidal. Labrum subsquarish; almost as wide as long. Mandibles typically *Neotermes*-type. Pronotum subrectangular; narrower than head (length 0.73-0.88, width 1.43-1.50 mm); anterior margin incurved, with a median notch. Legs and abdomen as in soldier.

*Distribution* : INDIA : Karnataka Shimoga. (13°55' N. 75°30' E), type-locality. Known only from type-locality.

### 32. *Neotermes venkateshwara* Bose

(Figs. 149, 150)

1984. *Neotermes venkateshwara* Bose, *Occ. Pap. Rec. zool. Surv. India*, No. 49: 15, 23, 47-52, 254, 264. S, Pw. Holotype : S, in ZSI, Calcutta. Type-locality : Topslip near Pollachi (Tamil Nadu, India). Type examined.

**IMAGO** : Unknown.

**SOLDIER** (Fig. 149) : Head-capsule yellowish brown, paler posteriorly; antennal foveolae, postclypeus and mandibles darker, dark reddish brown; labrum dark brown; thorax, legs and body pale golden yellow. Head and body sparsely hairy. Total body-length 9.2-9.8 mm. Head-capsule subrectangular with subparallel sides, widening a little just behind antennae; width about 2/3rd of head-length to base of mandibles (length 3.15-3.30, width 2.08-2.20 mm); frons sloping in front at about 45° angle; Y-suture prominent. Eyes oval, translucent; 0.20-0.28 mm long; situated about their length from antennae. Ocelli small, whitish, spot-like, situated at end of lateral arms of Y-suture. Postclypeus flat, not clearly differentiated from frons; with a pair of bristles at anterior margin. Anteclypeus narrow, strip-like, apilose, hyaline. Labrum broad, tongue-shaped; with round anterior margin having a few, long bristles. Antennae with 13-14 segments; segment

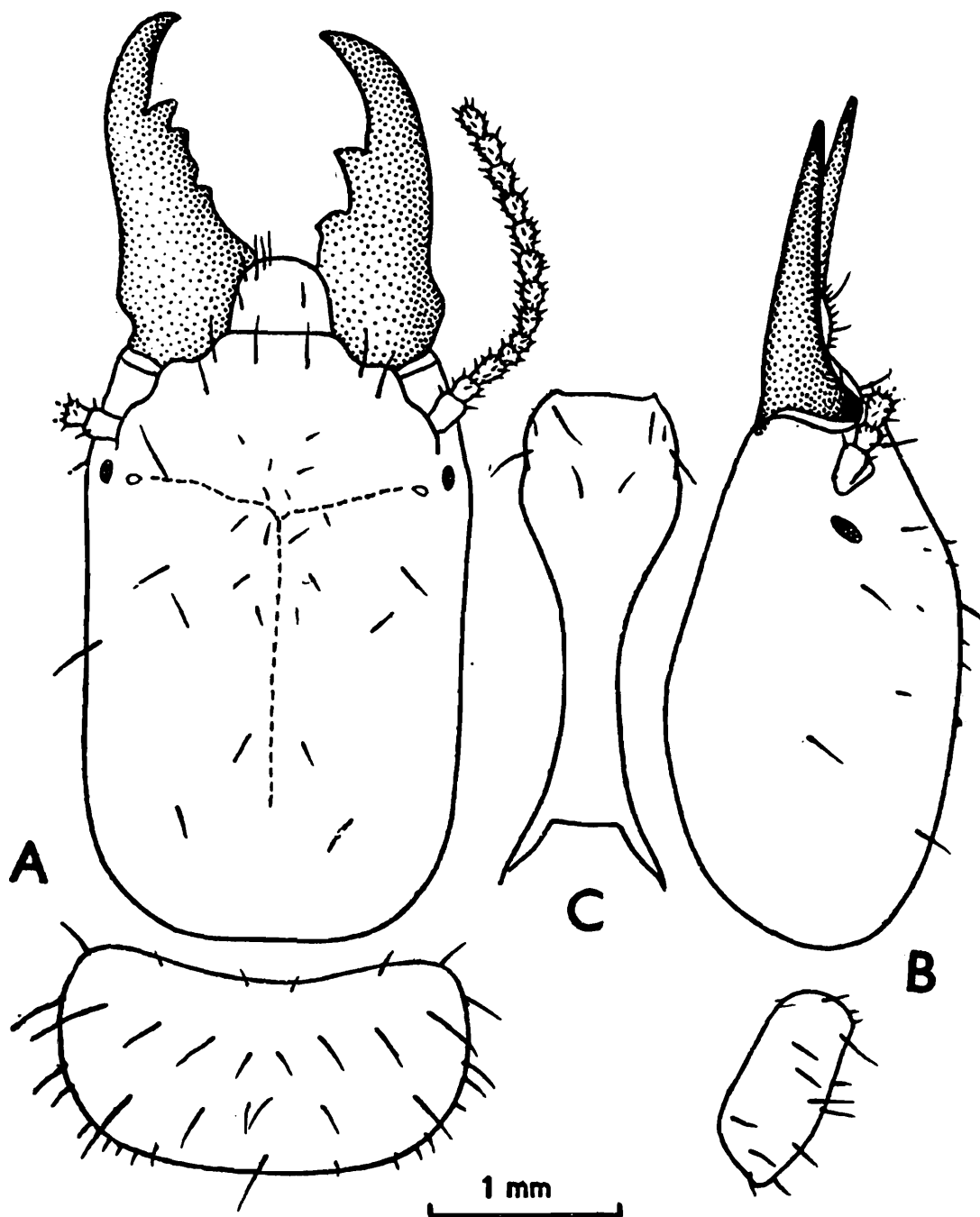

Fig. 149. *Neoterme venkateshwara*. Soldier. (A) Head and pronotum, in dorsal view. (B) Same, in side view. (C) Postmentum. (After Bose, 1984).

3 much longer than 2; 4 shortest. Mandibles short and with prominent humps on outer margin near base; apically narrow and incurved appreciably (length 1.75-1.80 mm, index Mandible-length/Head-length to base of mandibles 0.54-0.60). Left mandible with 4 marginal teeth and right with 2 large marginals situated medially. Postmentum, club-shaped, with a long

narrow waist; club bilobed, posterior lobe a little wider than anterior one; width at waist slightly more than  $1/3$ rd of maximum width of club; median length 2.26-2.40, max. width 0.78-0.84, width at waist 0.28-0.30 mm. Pronotum flat, subrectangular; with rounded sides, substraight posterior and weakly incurved anterior, margins; narrower than head (length 1.00-1.18, width 1.98-2.25 mm). Mesonotum and metanotum semicircular, narrower than pronotum; latter a little wider than former. Legs short and stout; apical tibial spurs 3:3:3; tarsi 4-jointed. Abdomen oblong, pilose; cerci 2-jointed, 0.18 mm long; styli single-jointed 0.15 mm long.

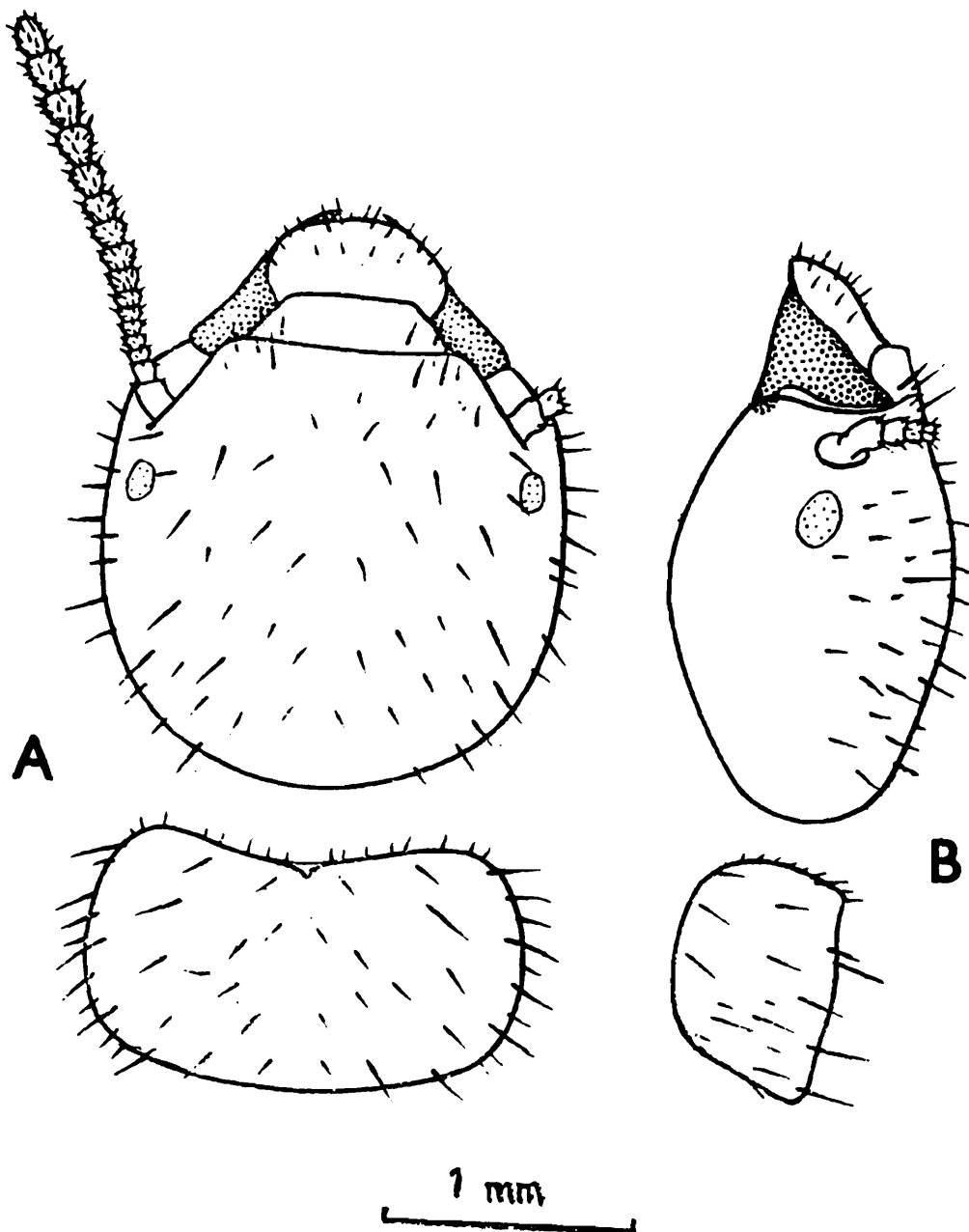

Fig. 150. *Neotermes venkateshwara*. Pseudowrocker. (A) Head and pronotum, in dorsal view. (B) Same, in side view. (After Bose, 1984).

**PSEUDOWORKER** (Fig. 150) : Head-capsule pale yellow; antennae, legs and body pale creamy white; clypeus and labrum pale brown. Head and body fairly pilose. Total body-length 8.6-9.1 mm. Head-capsule subcircular, almost as wide as long (length to base of mandibles 1.65-1.80, max. width 1.70-1.85 mm). Eyes broadly oval, about 0.30 mm in long diameter. Antennae with 15-16 segments; segment 4 shortest. Postclypeus flat, subtrapezoidal with 2-3 long bristles on either side. Anteclypeus flat, apilose. Mandibles typically *Neotermes*-type. Pronotum wider than head, subrectangular, flat; anterior margin slightly incurved; posterior margin weakly convex; length 1.03-1.10, width 2.00-2.10 mm. Legs and abdomen as in soldier.

*Distribution* : INDIA : Tamil Nadu : Topslip near Pollachi (type-locality).

## Genus 5. *Kalotermes* Hagen

### 1. *Kalotermes* Hagen

1853. Hagen, *Ber. K. Preussischen Akad. Wiss. Berlin* : 479, 480.
1960. Roonwal and Sen-Sarma, *Contrib. Syst. Orient. Termites* (ICAR Ent. Monogr. 1) : 97, 98, 99-102. (In part).
1961. Krishna, *Bull. Am. Mus. nat. Hist.*, 122 (Art. 4) : 315, 316, 317, 331-336, 384, 385, 386, 389. (Synonymy, generic characters, species included.)
1969. Emersou, *Am. Mus. Novit.*, No. 2359: 6, 11, 15, 28-31.
1970. Krishna, In *Biology of Termites* (Eds. Krishna and Weesner) Vol. 2 : 132, 133.
1970. Roonwal, In *Biology of Termites* (Eds. Krishna and Weesner) Vol. 2: 324.
1973. Chhotani and Rose, *Zool. Anz.*, 190 (3/4) : 232, 234.
1975. Chhotani, *Zool. Anz.*, 194 (1/2) : 111, 113, 115, 116, 118, 120, 121.
1977. Araujo, *Cat. Isoptera Novo Mundo* : 19.
1978. Roonwal and Rathore, *Zool. Anz.*, 200 (3/4) : 219, 229.
1980. Chhotani, *Tech. Monogr. Zool. Surv. India*, 4: 3, 17.
1983. Roonwal, *Proc. Indian natn. Sci. Acad.*, (B) 45(3) : 378.

Type of genus : *Termes flavicollé* Fabricius.

### 1. Characters of Genus *Kalotermes*

*Imago* : Dark and small in size. Head subcircular, sides without eyes subparallel. Eyes small, broadly oval; 0.25-0.35 mm in long diameter.

Ocelli oval, either touching eyes or faintly separated. Antennae 12-17 segmented. Anteclypeus flat, trapezoidal, whitish. Postclypeus flat, darker than frons. Mandibles each with an apical and two marginals. Left mandible with posterior margin of 1st (1st plus 2nd of some authors) equal to anterior margin of 2nd (3rd of some). Right mandible with posterior margin of 2nd marginal equal to molar plate. Pronotum flat, broader than head; anterior margin incurved. Wings dark; with papillae, pimples and tubercles; forewing with all major veins arising independently from scale; costa, subcosta, radius and radial sector strongly sclerotised; media and cubitus weak, unsclerotised; costa running along anterior margin; subcosta short meeting costa just outside scale; radius simple meeting costa-subcosta before middle; radial sector with 8-13 branches to costal border; media running medially between radial sector and cubitus, sometimes joining radial sector and again separating to meet distal tip; cubitus weak and with a number of branches to posterior margin. Hindwing venation as in forewing except media arising from radial sector in wing-membrane. Apical tibial spurs 3:3:3; arolium present.

*Soldier* : Head generally subrectangular, long, narrow and with subparallel sides; sometimes dorsoventrally flattened; frons generally depressed medially and sloping in front at angle of 40-50 degrees or truncated as in *K. atratus* (Hill) like in *Cryptotermes* soldier; Y-suture present or absent. Eyes small, oval, unpigmented. Antennae 11-18 segmented; segment 3 variable, either shorter or longer than 2. Labrum subsquarish with rounded anterior margin. Anteclypeus trapezoidal, whitish; postclypeus subrectangular, darker than frons. Mandibles strong and stout; with or without basal humps on outer margin. Left mandible with 3-5 and right with 2 marginal teeth. Postmentum long, club-shaped. Pronotum subrectangular, as wide as or wider than head; anterior margin broadly incurved; posterior margin weakly to appreciably convex. Femora generally swollen; apical tibial spurs 3:3:3; tarsi 4-jointed.

*Pseudoworker* : Whitish to creamish in colour. Head subcircular. Eyes present, pigmented. Ocelli absent. Antennae 13-15 segmented. Mandibles as in imago. Pronotum flat, anterior margin deeply incurved. Apical tibial spurs 3:3:3; tarsi 4-jointed.

*2: Distribution and Composition of Kaloterme*  
(Fig. 94)

Krishna (1961) has recognised 18 living and 4 fossil species and Emerson (1969), 18 living and 6 fossil species, from the world. The fossil species are known from Eocene, Oligocene and Miocene of Europe and Upper Burma (Emerson 1969). The living forms are distributed, thus: Oriental (2 species), Australian (7 species), Palaearctic (4 species), Ethiopian (2 species) Malagasy (one species), Nearctic (one species) and Neotropical (one species). Of the two oriental species, only one viz. *K. jepsoni* Kemner, occurs in the Indian region in Sri Lanka.

**33. *Kaloterme jepsoni* Kemner**  
(Figs. 151-153)

*Kaloterme jepsoni* Kemner :

1932. Kemner, *Ent. Tidsk.*, **53**(2-3): 146-149. Im, S. Lectotype : S (selected, Roonwal and Sen-Sarma, 1961), deposited in "Entomologiska Avdelningen" Zoological Institute, Lund University, Lund (Sweden). Type examined. Type locality Maskeliya, Sri Lanka.
1949. Snyder, *Smiths. misc. Colls.*, **112**: 16.
1960. Roonwal and Sen-Sarma, *Contrib. Syst. Orient. Termites*, (ICAR Ent. Monogr. No. 1): 117-122, pls. 22, 23.
1961. Krishna, *Bull. Am. Mus. nat. Hist.*, **122** (Art. 4) : 336.
1967. Roonwal and Chhotani, *J. Bombay nat. Hist. Soc.*, **63**(2): 362.
1970. Roonwal, In *Biology of Termites* (Eds. Krishna and Weesner) Vol. 2: 324-325.
1975. Chhotani, *Zool. Anz.*, **194** (1/2) : 112, 113, 115, 118.
1980. Chhotani, *Tech. Monogr. Zool. Surv. India*, No. 4: 17-18.

IMAGO (Figs. 151, 152) : Head, thorax and abdomen dark brown; antennae, legs and abdominal sternites yellowish brown; mandibles basally deep straw coloured, rest black. Head and body sparsely pilose. Total length with wings 10.50-12.0, without wings 5.5-6.5 mm. Head-capsule subrectangular, very slightly broader than long; length to base of mandibles

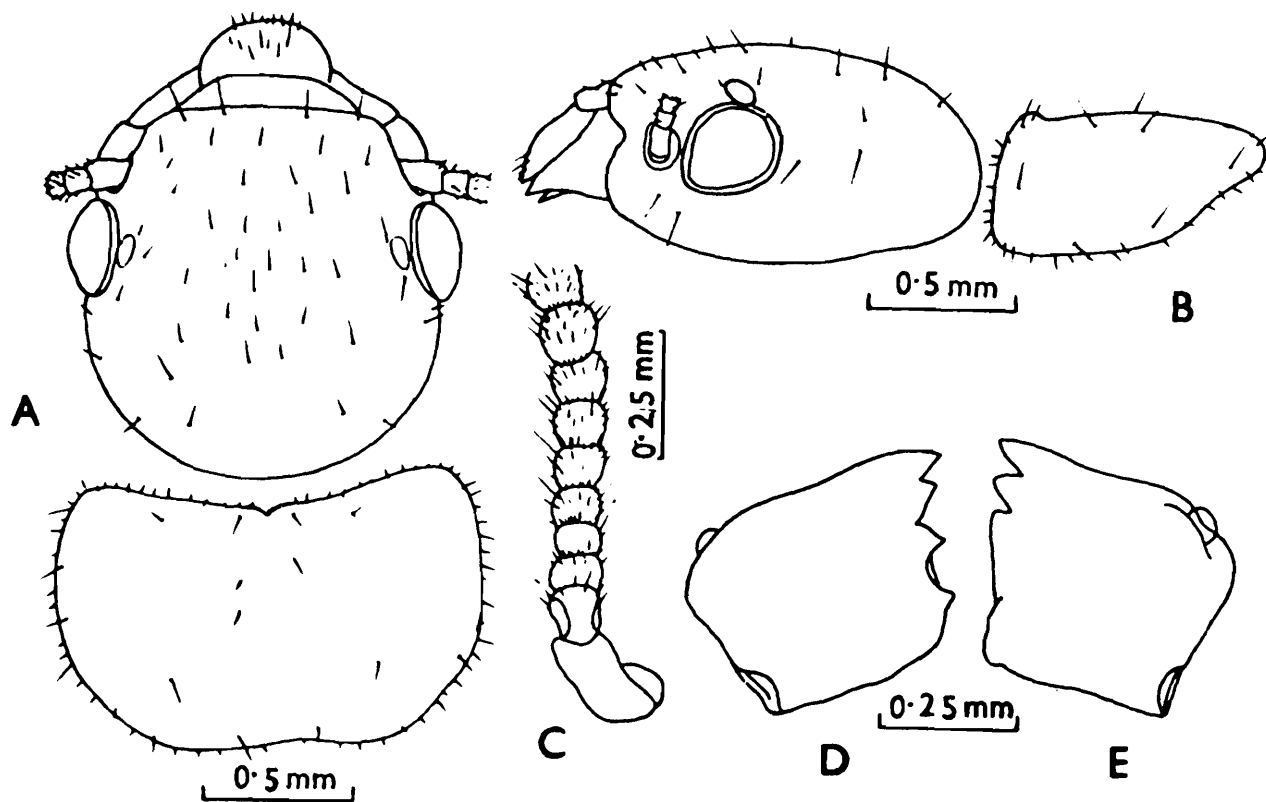

Fig. 151. *Kalotermea jepsoni*. Imago. (A) Head and pronotum, in dorsal view. (B) Same, in side view. (C) Basal part of antenna. (D) and (E) Left and right mandibles. (Redrawn from Roonwal and Sen-Sarma, 1960)

1.2, width with eyes 1.27-1.3 mm; sides subparallel; posterior margin rounded; frons gently sloping in front, medially depressed; Y-suture not visible. Eyes black, small, subcircular (max. diameter 0.35 mm.); lying close to antennal sockets. Ocelli oval, translucent; lying very close to eyes, almost touching ocular sclerite; max. diameter 0.10 mm. antennae 15-16 segmented, thickly pilose; 4th segment shortest. Anteclypeus trapezoidal, whitish, apilose. Postclypeus flat, subrectangular, slightly darker than frons; with 2 pairs of longish hairs on anterior margin. Labrum short, subrectangular; length 0.35, width 0.50 mm; anteriorly rounded; with a few hairs on tip and body. Mandibles as in genus. Pronotum subrectangular, length 0.71-1.0, width 1.27-1.4 mm; generally a little broader than head; sides slightly convergent posteriorly; anterior margin shallowly concave; posterior margin substraight, medially incurved. Legs short, thick, pilose; tibial spurs 3:3:3; tarsi 4-segmented; empodium between claws brownish, prominent. Wings brownish, coarsely tuberculate. Forewing Scale much larger than in

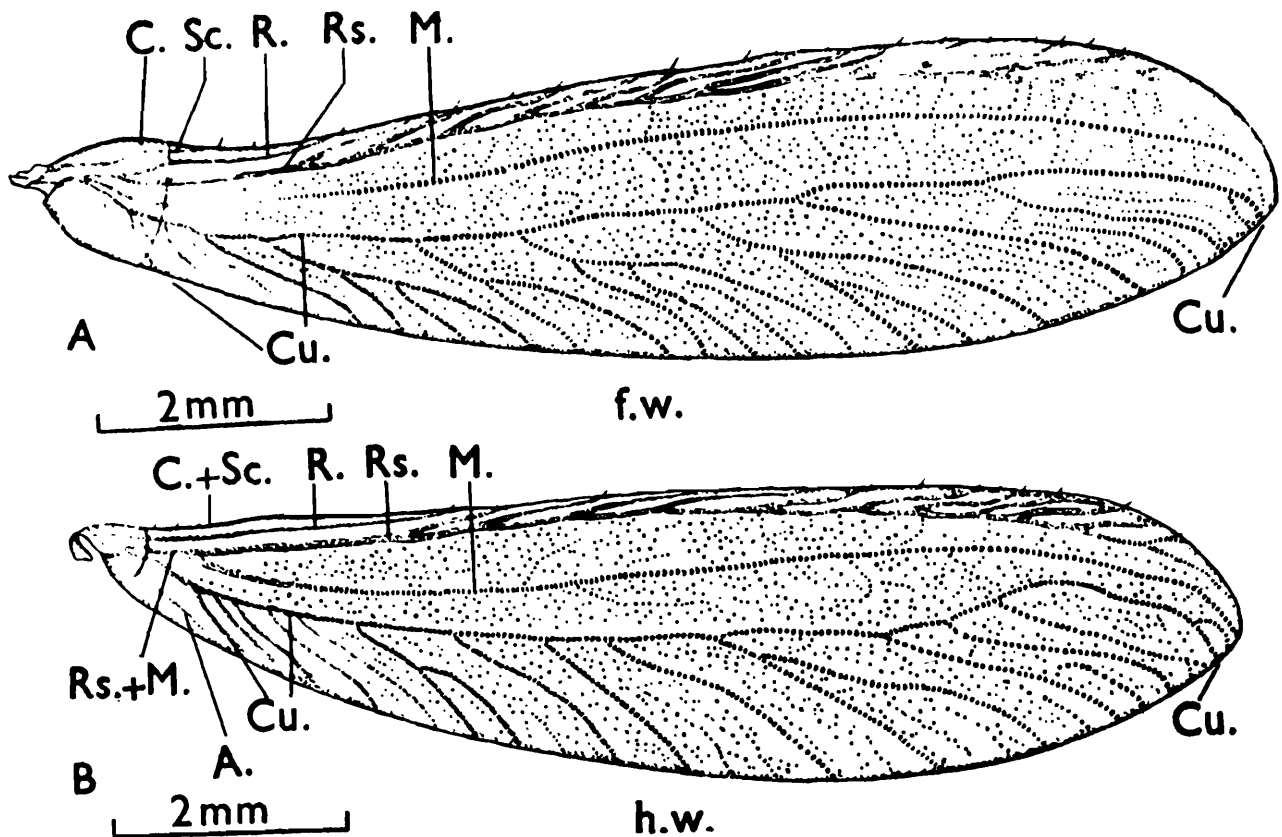

Fig. 152. *Kalotermea jepsoni*. Wings. (A) Right forewing. (B) Right Hindwing.

A., anal; C., costa; Cu., cubitus; f.w., forewing; h.w., hindwing; M., media; R., radius; Rs., radial sector; Sc., subcosta. (After Roonwal and Sen Sarma, 1960).

hindwing; length without scale 8.94-9.33 mm; venation as in genus; radius, however, short and fusing with costa at about the proximal sixth of wing-length, radial sector with 12-13 oblique branches to costal border and cubitus with 10-12 branches to posterior margin; a few cross veins present between media and radial sector and media and cubitus. Hindwing : Venation as in forewing except radius fusing with costa-subcosta at about proximal third or fourth of wing length without scale; radial sector giving off 8-11 branches to costa, media arising from radial sector outside scale, cubitus giving off 12-14 branches to posterior margin and a small anal vein present. Abdomen, elongate, pilose; cerci short, pilose, 2-segmented.

**SOLDIER** (Fig. 153) : Head capsule anteriorly brown, posteriorly paler; head-sides pale brown; antennae proximally brownish, distally yellowish; labrum pale straw coloured; mandibles blackish brown; pronotum and legs

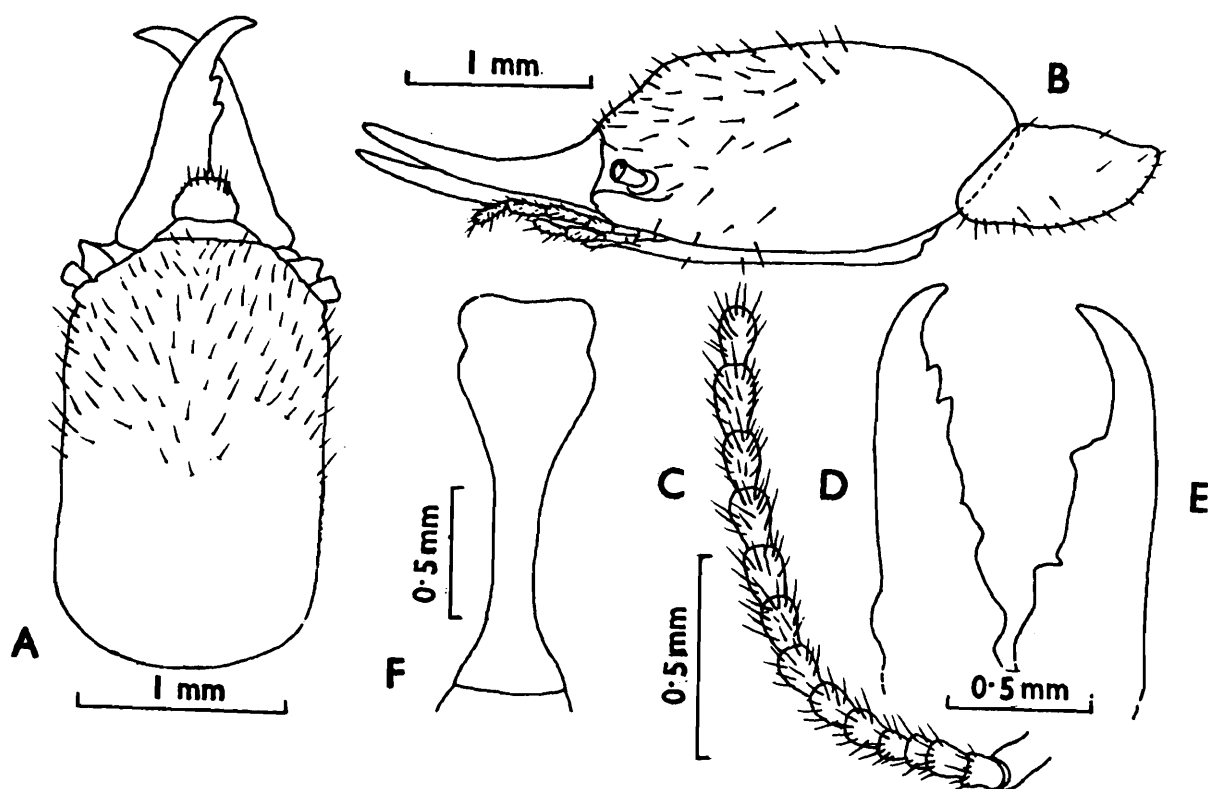

Fig. 153. *Kaloterмес jepsoni*. Soldier. (A) Head, in dorsal view. (B) Head and pronotum, in side view. (C) Antenna. (D) and (E) Left and right mandibles. (F) Postmentum. (Redrawn from Roonwal and Sen-Sarma, 1960).

yellow, abdomen pale. Head and body sparsely pilose. Total length c 6.73-8.81 mm. Head-capsule subrectangular, much longer than broad; length to base of mandibles 2.1-2.4, width 1.34-1.50 mm; sides subparallel and posterior margin round; frons sloping sharply; Y-suture absent. Eyes and ocelli absent. Antennae short, 14-segmented, pilose, pilosity increasing distally; segment 3 strongly chitinized, longer than 2; 4th shortest. Anteclypeus whitish, well developed, apilose; subequal to postclypeus in length. Postclypeus subrectangular; slightly darker than frons; with 2-3 pairs of hairs at anterior margin. Labrum large, tongue-shaped; sides converging to a truncate, weakly rounded anterior margin; with several long hairs near distal margin and body. Mandibles long, slender, apically weakly curved and without basal humps; length about two-thirds of head-length to base of mandibles. Left mandible with 5 marginal teeth and right with 2 large, subequal marginal teeth near about middle. Postmentum long, club-shaped;

anterior part broad, bilobed; narrowing posteriorly to a long, narrow waist and again widening out at base; anterior margin substraight; length 1.80-1.92, maximum width 0.54-0.56 and minimum width 0.12 mm. Pronotum trapezoidal, much broader than long; width 1.26-1.48, length 0.77-1.02 mm; sides converging to weakly convex posterior margin; anterior margin deeply concave with a slight median notch; body sparsely pilose but with numerous hairs on margin. Legs short, thin, pilose; hind femora not swollen; apical tibial spurs 3:3:3; tarsi 4-segmented. Abdomen long, slender, each tergum with a transverse row of sparse hairs; cerci short, 2-segmented, pilose.

**PSEUDOWORKER.** Head-capsule and base of mandibles straw coloured, rest of mandibles blackish brown; antennae, labrum, pronotum and legs yellowish; body pale. Head densely and body sparsely pilose. Total length c 4.7-5.5 mm. Head-capsule subsquarish; length to base of mandibles 1.1-1.2, width 1.15-1.2 mm; frons gently sloping in front. Eyes rudimentary, whitish, flush with head-surface, visible only in strong light. Ocelli absent. Antennae pilose, 13-14 segmented; 3-5 subequal, short. Anteclypeus trapezoidal, whitish; postclypeus rectangular, darker than frons. Labrum subrectangular, pilose at tip; anterior margin rounded. Mandibles as in genus. Pronotum subrectangular, length 0.60-0.7, width 1.1 mm; almost as broad as head; anterior margin concave; sides rounded; posterior margin straight. Legs and abdomen as in soldier.

*Distribution* : SRI LANKA : Maskeliya and Pundaluoya.

### Genus 6. **Glyptotermes** Froggatt

(Synonym : *Lobitermes* Holmgren)

1. *Calotermes* Hagen (Part) :

1858. Hagen, *Linn. Ent.*, 12: 31-38.

2. *Glyptotermes* Froggatt :

1896. Froggatt, *Proc. Linn. Soc. N.S.W.*, 21(4): 518-543.

1949. Snyder, *Smiths. misc. Colls.*, 112: 45, 359 (see for other references also).

1961. Krishna, *Bull. Amer. Mus. nat. Hist.*, 122 (Art. 4) : 313, 314, 315, 316, 317, 343-348, 384, 385, 386 (see for other references also).

1970. Roonwal, In *Biology of Termites* (ed. Krishna and Weesner) Vol. 2: 325.

1972. Chhotani, In *Termite Problems in India* (ed. M.L. Roonwal) : 23, 24.
1973. Chhotani and Bose, *Zool. Anz.*, **190**: 232, 234.
- 1975a. Chhotani, *Zool. Anz.*, **194**: 113-116, 118, 121, 122.
- 1975b. Chhotani, *Rec. zool. Surv. India*, **68**: 109, 110, 111-118, 157 (see for detailed synonymy also).
1975. Akhtar. *Bull. Dept. Zool. Univ. Punjab* (N.S.), Art. 7: 4, 15-27.
1980. Chhotani, *Tech. Monogr. Zool. Surv. India*, No. 4: 3, 18-19.
1983. Maiti, *Occ. Pap. Rec. zool. Surv. India*, No. 42: 16, 20, 33-40.
1984. Fan and Xia, *Contr. Shanghai Inst. Entomol.*, 1982-83 : 163-164, 170-171.
1984. Bose, *Occ. Pap. Rec. zool. Surv. India*, No. 49: 16, 17, 18, 52-53.
1986. Grassé, *Termitologia* Vol. 3: 516.
3. *Lobitermes* Holmgren :
1911. Holmgren, *K. Sv. Vet. Akad. Handl.*, **46**(6): 53, 56, 59-61.
1975. Chhotani, *Rec. zool. Surv. India*, **68**: 116.

Type of genus (i). *Glyptotermes tuberculatus* Froggatt (by subsequent designation), (ii). Of *Lobitermes* : *L. lobicephalus* (Silvestri).

### 1. Characters of Genus *Glyptotermes*

*Imago* : Head-capsule quadrate or subcircular; epicranial suture generally present. Eyes moderately large, broadly oval. Ocelli oval; either touching the eyes or separated. Antennae with 11-17 segments. Clypeus flat, trapezoidal, not clearly differentiated into ante- and postclypeus. Labrum broadly tongue-shaped. Mandibles each with an apical and two marginal teeth; apical finger-like; margin between 1st and 2nd marginals either notched or incurved, when notched posterior margin of 1st subequal to anterior margin of 2nd; posterior margin of 2nd marginal of right mandible slightly longer than molar plate. Pronotum flat, narrower than or as wide as head with eyes. Wings smoky brown, strongly tuberculate; all veins strongly chitinised and thick, except cubitus; costa running along anterior margin; subcosta short, fusing with costa just outside scale in forewing, absent in hindwing; radius fusing with costa a little away from scale; radial sector and media running close to and parallel with costa upto distal tip, the latter arising independently in forewing and from radial sector in hindwing; cubitus weak, running medially and with a number of branches

to posterior margin. Legs with 3:3:3 apical tibial spurs; tarsi 4-jointed; arolium present. Abdomen elongate, cerci 2-jointed.

*Soldier* : Head-capsule subrectangular, cylindrical; sometimes phragmotic with frons sharply sloping in front and incurved as in *Cryptotermes*; bilobed in front with U-or V-shaped depression; with antero-dorsal protuberences which may be faintly marked to fairly prominent; epicranial suture generally present. Eye-spots present, minute, dot-like. Antennae with 10-15 segments. Clypeus divided into ante- and postclypeus; distinctly or faintly demarcated from frons. Labrum tongue-shaped. Mandibles generally thick and stout, either humped or not above condyle at outer margin; dentition prominent. Postmentum long or short, club-shaped. Pronotum flat, weakly narrower to somewhat broader than head. Legs with 3:3:3 apical tibial spurs and 4-jointed tarsi. Abdomen elongate; cerci 2-jointed.

*Pseudoworker* : Head-capsule subcircular, broader than its length to base of mandibles. Eyes rudimentary, unpigmented. Ocelli absent. Antennae with 9-12 segments. Mandibles as in imago. Pronotum narrower to a little wider than head-capsule. Legs and abdomen as in soldier.

## 2. *Distribution and Composition of Glyptotermes* (Fig. 154)

Fortyfive living and one fossil species of the genus *Glyptotermes* were recorded by Snyder 1949. Chhotani (1975a), while revising the Indian species and taking into account all the species described till then, reported 73 living and one fossil species and gave their number in different zoogeographical regions. Since Chhotani (1975a), 27 more living species have been described thus 5 from the Indian subregion, 7 from Sabah (Malaysia), one each from Thailand and Japan and 13 from China. From the Indian subregion the following 12 species are known :

1. *Glyptotermes almorensis* Gardner. India.
2. *G. arshadi* Akhtar. Bangladesh.
3. *G. ceylonicus* Holmgren. Sri Lanka.
4. *G. coorgensis* Holmgren and Holmgren. India.
5. *G. dilatatus* (Bugnion and Popoff). Sri Lanka.

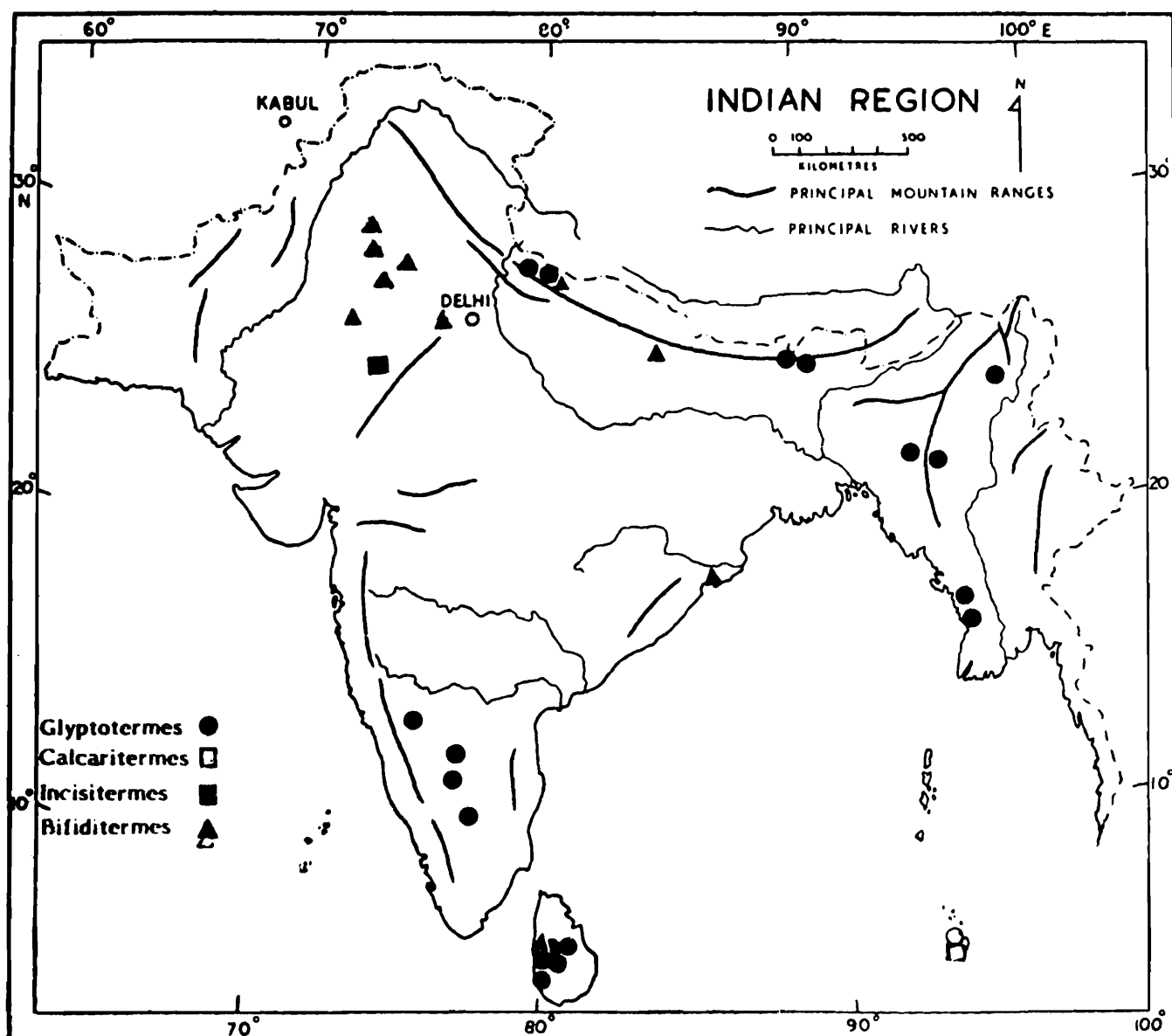

Fig. 154. Map of the Indian Region, showing distribution of genera *Glyptotermes*, *Calcaritermes*, *Incisitermes* and *Bifiditermes* (Kalotermitidae).

6. *G. minutus* Kemner. Sri Lanka.
7. *G. nicobarensis* (Maiti and Chakraborty). India.
8. *G. sensarmai* Maiti. India.
9. *G. teknaensis* Akhtar. Bangladesh, India.
10. *G. tikaderi* Chhotani and Bose. India
11. *G. tripurensis* Thakur. India
12. *G. ukhiaensis* Akhtar. Bangla Desh, India.

### 3. Keys to Indian Region Species of *Glyptotermes* IMAGOES

- 1(6) Larger species. Head-width with eyes over 1.0 mm (1.03-1.30 mm); antennae 13-15 segmented
- 2(3) Darker species. Head dark brown with smoky tinge..... *teknafensis*
- 3(2) Paler species. Head brownish yellow or pale brown
- 4(5) Y-suture on head distinct; pronotum with narrowly rounded antero-lateral corners..... *ceylonicus*
- 5(4) Y-suture on head not distinct; pronotum with broadly rounded antero-lateral corners..... *dilatatus*
- 6(1) Smaller species. Head-width with eyes less than 1.0 mm (0.73-0.97 mm); antennae 11-12 segmented
- 7(8) Head smaller; head-width 0.73-0.86 mm..... *ukhiaensis*
- 8(7) Head larger; head-width 0.85-0.97 mm
- 9(12) Ocelli larger, 0.09 mm long and 0.07-0.09 mm wide
- 10(11) Head width 0.90-0.97; Y-suture on head distinct; pronotum-width 0.77-0.83 mm..... *almorensis*
- 11(10) Head-width 0.85; Y-suture on head indistinct; pronotum-width 0.73 mm..... *minutus*
- 12(9) Ocelli smaller, 0.07-0.08 mm long and 0.05-0.07 mm wide
- 13(14) Ocelli touching the eyes [Head-width 0.87-0.93 mm; Y-suture distinct; pronotum with weakly incurved anterior margin]..... *coorgensis*
- 14(13) Ocelli not touching the eyes [Head-length to base of mandibles 0.88-0.95 and width with eyes 0.84-0.92 mm; pronotum length 0.53-0.56 and width 0.82-0.86 mm]..... *nicobarensis*

### SOLDIERS

- 1(8) Larger species: Total body-length 6.5-11.2, head-length to base of mandibles 1.90-3.5, head-width 1.30-2.05 mm
- 2(7) Frons sharply inclined in front, angle of inclination more than 60°
- 3(6) Head-length to base of mandibles 2.6-3.5, head-width 1.5-2.05 mm; frontal protuberances on head broad and weak and antero-lateral corners of head rounded; mandibles shorter in comparison to head
- 4(5) Larger species: head-length to base of mandibles 3.2-3.5, head-width 1.90-2.05 mm; antennae 14 to 15-segmented; mandibles longer in comparison to head-length (index left mandible-length/head-length to base of mandibles 0.44-0.46)..... *tikaderi*

- 5(4) Smaller species: Head-length to base of mandibles 2.67-3.00, head-width 1.50-1.67 mm; antennae 12-segmented; mandibles shorter in comparison to head-length (index left mandible-length/head-length to base of mandibles 0.33-0.36..... *ceylonicus*
- 6(3) Head-length to base of mandibles 1.90-2.33, head-width 1.30-1.40 mm; frontal protuberances on head sharp and prominent and antero-lateral corners pointed; mandibles longer in comparison to head *dilatatus*
- 7(2) Frons less so sharply inclined, angle of inclination 45°-50° [Head-length without mandibles 1.93-2.27, head-width 1.25-1.40 mm] ... *teknafensis*
- 8(1) Smaller species: Total body-length 4.0-7.0, head-length to base of mandibles 1.13-1.73, head-width 0.80-1.20 mm
- 9(16) Head width less than 1.00 mm
- 10(11) Eyes absent; tenth abdominal tergite not strongly sclerotised; antero-lateral corners of head sharply pointed..... *arshadi*
- 11(10) Eyes present; tenth abdominal tergite strongly sclerotised; antero-lateral corners of head rounded
- 12(13) Ocelli absent and epicranial sutures faint or absent..... *ukhiaensis*
- 13(12) Ocelli present and epicranial sutures prominent
- 14(15) Postmentum with broader portion large and sharply and strongly incurving at waist..... *tripurensis*
- 15(14) Postmentum with broader portion small and gradually and weakly incurving at waist..... *minutus*
- 16(9) Head width more than 1.00 mm
- 17(20) Antero-lateral corners of head-capsule sharply pointed in front.
- 18(19) Mandibles with prominent basal humps on outer margin and comparatively weakly incurved anteriorly; margin between 2nd and 3rd marginal teeth of left mandible sharp, angularly incurved; ocelli present; postmentum broader at waist..... *coorgensis*
- 19(18) Mandibles with weaker basal humps on outer margin and comparatively strongly incurved anteriorly; margin between 2nd and 3rd marginal teeth of left mandible roundly incurved; ocelli absent; postmentum narrower at waist ..... *sensarmai*
- 20(17) Antero-lateral corners of head-capsule rounded in front
- 21(22) Head comparative to length wider (width/length to base of mandibles 0.67-0.77); Y-suture incomplete; lateral arms indistinct; mandibles longer in comparison to head-length to base of mandibles, index mandible length/head-length 0.45-0.47..... *almorensis*
- 22(21) Head comparative to length narrower (width/length to base of mandibles 0.59-0.66); Y-suture complete, lateral arms distinct; mandibles shorter in comparison to head-length to base of mandibles, index 0.53-0.41..... *nicobarensis*

### 34. *Glyptotermes almorensis* Gardner (Figs. 155-158)

#### 1. *Kalotermes (Glyptotermes) almorensis* Gardner:

1944. Gardner, *Indian J. Ent.*, 6: 104-105, fig. 1 (Soldier mandibles). Im, S. Lectotype: S, in FRI, Dehra Dun (examined). *Type-locality* : Bajwar (Almora District, Uttar Pradesh, India).

#### 2. *Glyptotermes almorensis* Gardner:

1949. Snyder, *Smiths. misc. Colls.*, 112: 45.

1975. Chhotani, *Zool. Anz.*, 194: 118.

1975. Chhotani, *Rec. zool. Surv. India*, 68: 110, 113, 114, 117, 118, 128, 141, 155, 157 (see for other references also).

1975. Sen-Sarma et al., *Wood Destroying Termites of India (Final Tech. Rept. PL 480 Project)*: 52.

1980. Sen-Sarma and Thakur, *Indian For. Rec. (N.S.) Ent.*, 14(1): 5-7.

1980. Chhotani, *Tech. Monogr. Zool. Surv. India*, No. 4: 4, 19-20.

1981. Maiti and Chakraborty, *Bull. zool. Surv. India*, 4(1): 83.

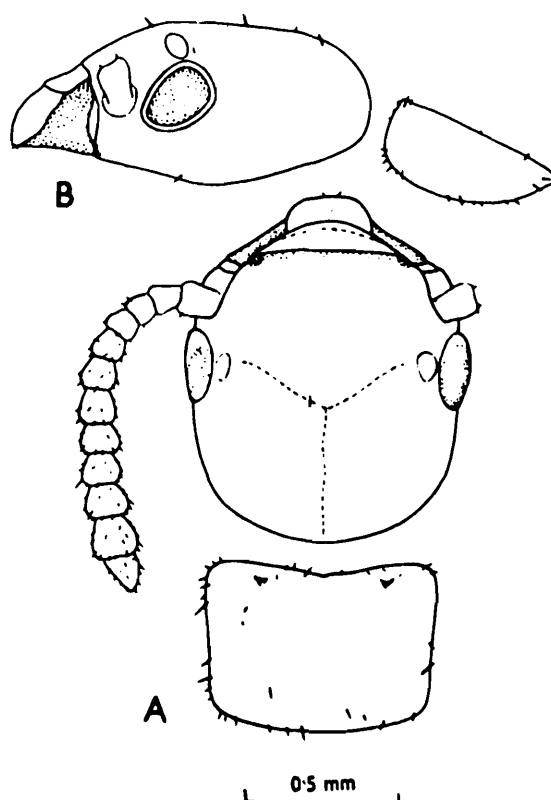
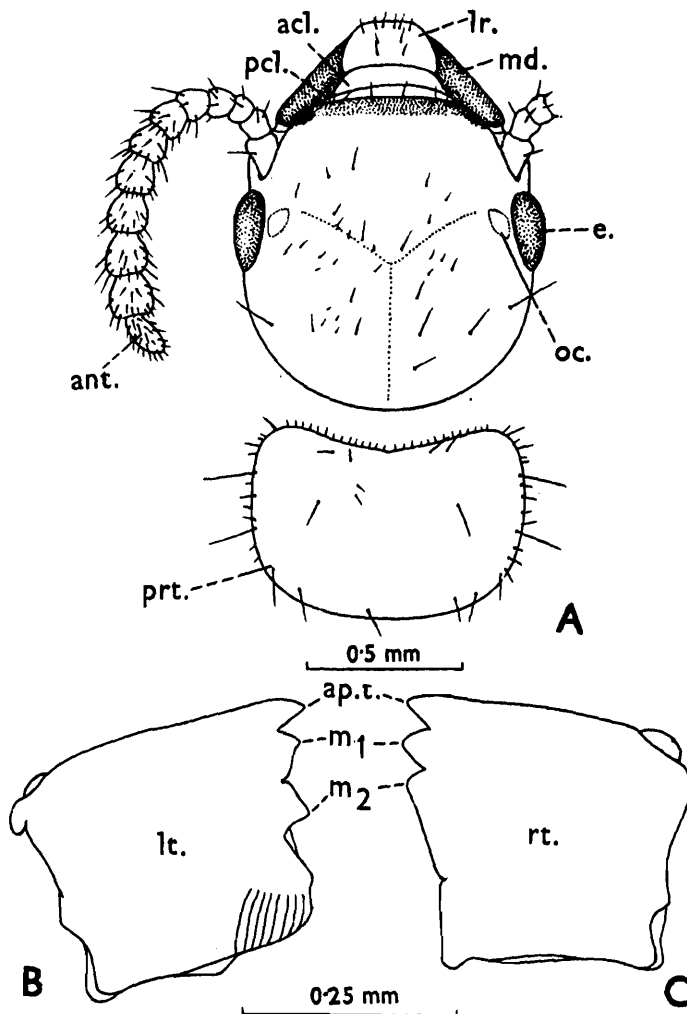

Fig. 155. *Glyptotermes almorensis*. Imago (Paralectotype). (A) Head and pronotum, in dorsal view. (B) Same, in side view. (Redrawn from Chhotani 1975a).

**IMAGO (Figs. 155-157) :** Head-capsule, pronotum and abdominal tergites castaneous brown; sternites paler; coxae and femora dark brown; labrum, antennae, tibiae and tarsi pale brown; wings dark brown. Head and body sparsely hairy. Total body length with wings c 7.2-8.1, without wings 4.2-5.4 mm. Head-capsule generally as long as or sometimes shorter than its width with eyes (length to base of mandibles 0.90-0.97, width 0.90-0.97 mm); head-sides without eyes substraight. Eyes small, oval, narrow in front 0.23-0.25 mm in long diameter; from lateral margin of head situated at a distance of two-thirds their diameter. Ocelli small (0.09 mm diameter), oval, translucent, either touching eyes or slightly separated; from antennae situated at about twice their diameter. Antennae with 12 segments; segment 2 longer than half of 1 and slightly longer than 3. Clypeus subtrapezoidal, indistinctly divided into ante- and postclypeus. Labrum broadly tongue



**Fig. 156.** *Glyptotermes almorensis*. Imago. (A) Head and pronotum in dorsal view. (B) and (C) Left and right mandibles.

acl., anteclypeus; ant. antenna; ap. t., apical tooth of mandibles; e., eye; lr., labrum; lt., left; m<sub>1</sub>, m<sub>2</sub>, 1st and 2nd marginal teeth of mandibles; md., mandible; oc., ocellus; pcl., postclypeus; prt., pronotum; rt., right. (After Chhotani, 1975a).

-shaped (length 0.17-0.25, width 0.30-0.33 mm), hairy near anterior margin and on body. Mandibles typically *Glyptotermes*-type. Pronotum sub-rectangular, narrower than head with eyes; anterior margin weakly incurved; posterior margin substraight; sides rounded (length 0.53-0.60, width 0.77-0.83 mm). Wings dark brown, covered with tubercles; venation as in genus; radius fusing with costa at about one-sixth of wing membrane in

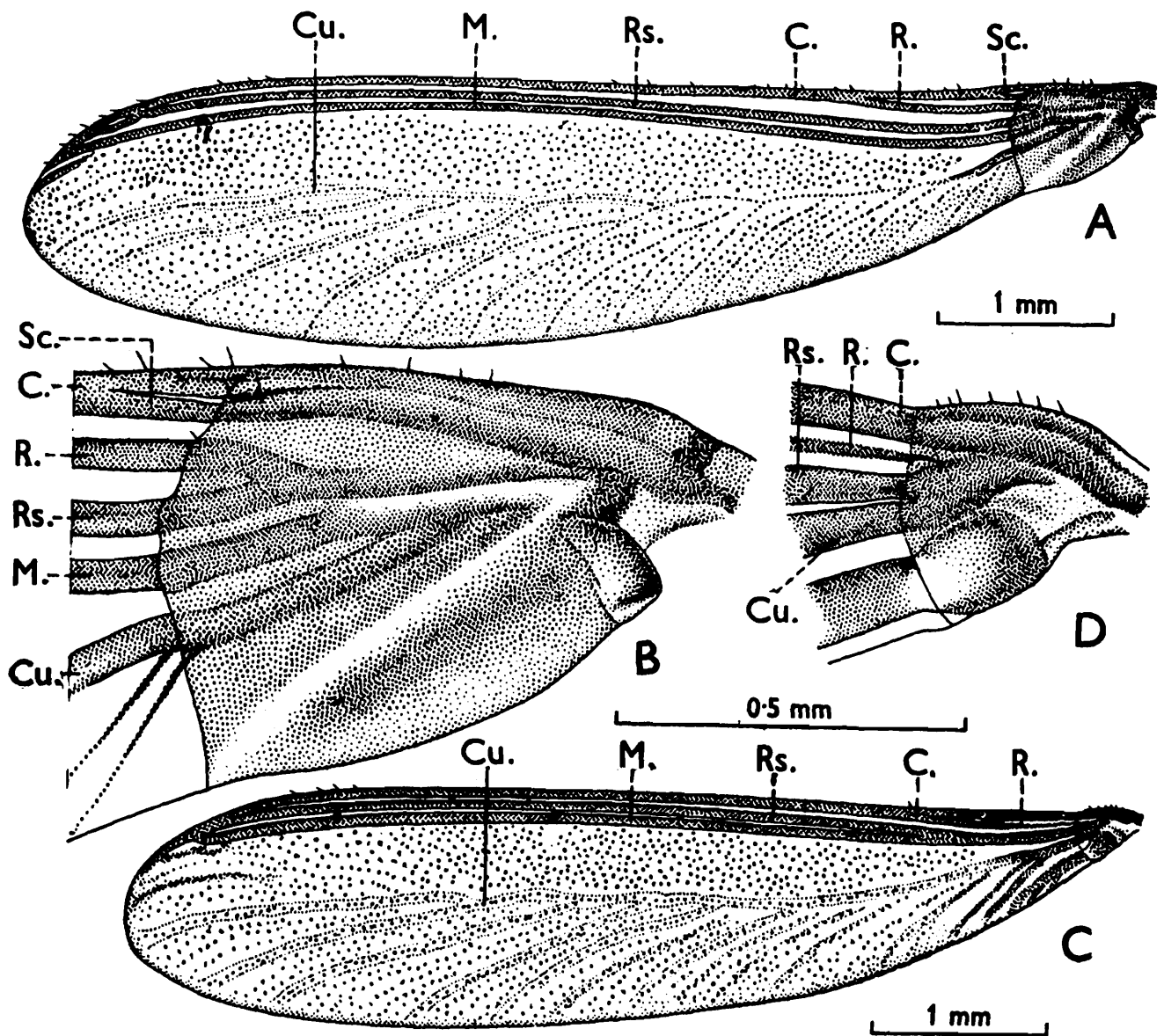

Fig. 157. *Glyptotermes almorensis*. Wings. (A) Left forewing. (B) Basal part of forewing, enlarged. (C) Left hindwing. (D) Basal part of hindwing, enlarged.

C., costa; Cu., cubitus; M., media; R., radius; Rs., radial sector; Sc., subcosta. (After Chhotani, 1975a).

both wings; media in hindwing arising from radial sector at about one-fourth to one-sixth of wing-membrane; cubitus with 11-14 and 12-13 branches to posterior margin in fore- and hindwings, respectively; cross veins between media and cubitus sometimes present. Forewings 5.70-6.3 and hindwing 5.40-5.80 mm in length. Legs short, hairy, otherwise as in genus; apical tibial spurs 3:3:3. Abdomen oblong, hairy; cerci 2-jointed; styli in males single-jointed.

**SOLDIER (Fig. 158)** Head-capsule reddish brown, paler posteriorly and darker anteriorly; mandibles blackish; antennae, labrum, legs and abdomen pale yellowish brown; last abdominal tergite dark testaceous. Head and body sparsely hairy. Lectotype paler and has lost hairs due to faulty preservation. Total body-length 4.8-5.7 mm. Head-capsule flat, subrectangular, about one-and-a-half times as long as wide; length to base of mandibles 1.43-1.73, width 1.07-1.13 mm; frons sloping in front, weakly depressed medially, antero-dorsal protuberances at base of frons absent or weak; Y-suture faint, lateral arms indistinct. Eyes oval, small, unpigmented, flush with head surface; from antennal sockets situated at distance of their short diameter. Antennae with 11-12 segments; segment 2 about half of 1, 3 shorter than 2, subequal to or slightly longer than 4, sometimes subdivided. Clypeus subtrapezoidal; anteclypeus thin, apilose, strip-like; postclypeus pilose, differentiated from frons by thin groove. Labrum broadly tongue-shaped, weakly wider than long (length 0.10-0.25, width 0.27-0.30 mm). Mandibles short, stout, 0.67-0.77 mm long; shorter than half of head-length. Left mandible with 3 marginal teeth; 1 and 2 short, situated in distal third; 3 larger, situated in middle third and separated from 2nd by roundly incurved margin. Right mandible with 2 marginal teeth in middle third. Postmentum long, club-shaped; at waist about half of its maximum width; length 0.90-1.10, max. width 0.40-0.43 and width at waist 0.20-0.21 mm. Pronotum subrectangular, weakly narrower than head; anterior margin weakly concave and faintly notched medially; posterior margin nearly straight; length 0.60-0.63, width 1.03-1.07 mm. Mesonotum narrower and metanotum as wide as pronotum, both substraight at posterior margin. Legs short, hairy; apical tibial spurs 3:3:3. Abdomen oblong; cerci 2-jointed.

**PSEUDOWORKER** : Head-capsule pale brown; antennae, labrum and body paler. Head and body sparsely hairy. Total body-length 4.5-5.0 mm.

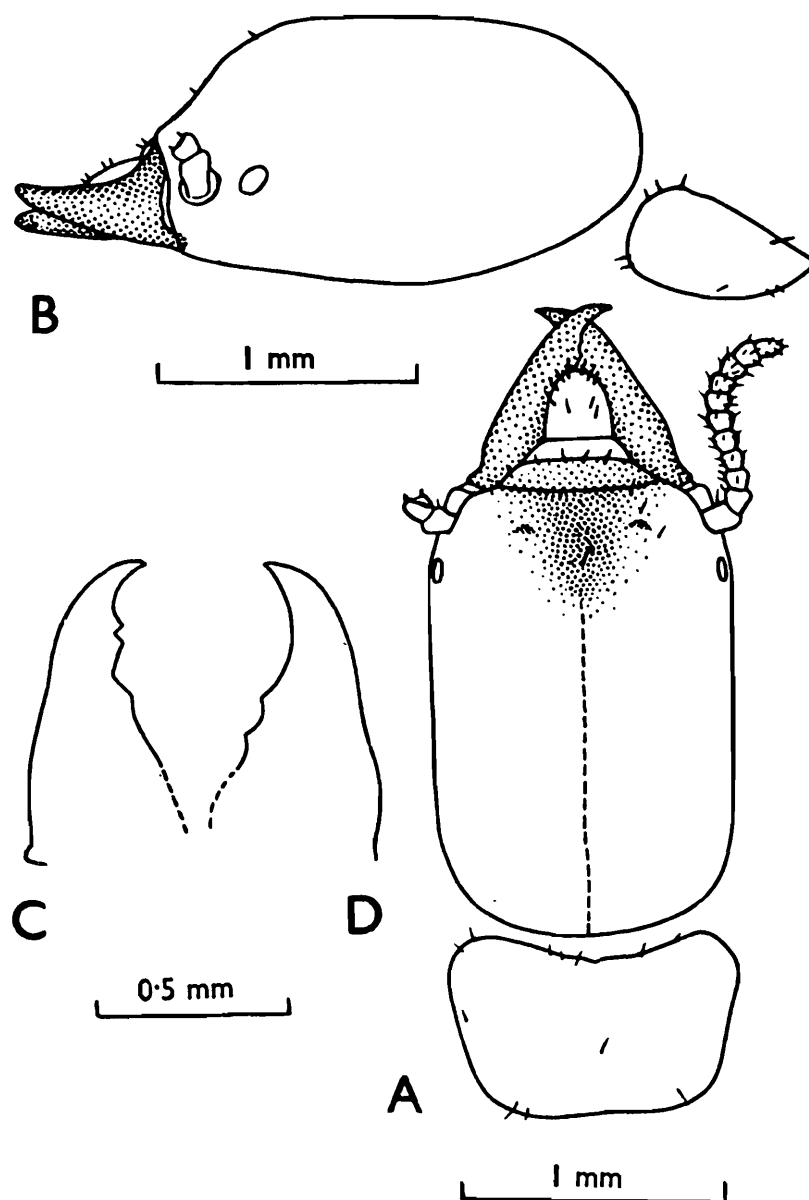

Fig. 158. *Glyptotermes almorensis*. Soldier (Lectotype). (A) Head and pronotum, in dorsal view. (B) Same, in side view. (C) and (D) left and right mandibles. (Redrawn from Chhotani 1975a).

Head-capsule subcircular; length to base of mandibles 1.00, width 0.93-1.03 mm. Eye spots present, unpigmented. Antennae with 10-11 segments; segment 2 little longer than half of 1, 3 shortest. Clypeus, labrum and mandibles as in genus. Pronotum subrectangular, as wide as or slightly narrower than head-capsule; anterior margin concave, posterior margin substraight; length 0.57, width 0.90-1.00 mm. Legs and abdomen as in soldier.

**Distribution :** This species is reported only from Kumaon Hills in Uttar Pradesh, India, thus Bajwar, Almora (type-locality); Barachina Range, Almora; Kandadhar Forest Dholakot, Askot; Bageshwar; and Paithani (Garhwal District).

**Biology :** *Glyptotermes almorensis* has been reported from dead and dry branches and main stem of *Celtis australis*, *Mangifera indica*, *Rhododendron arboreum* and *Shorea robusta*. It is an important wood destroying species in Kumaon Hills and the wood it infests is riddled with galleries sometimes damaging the entire piece.

### 35. *Glyptotermes arshadi* Akhtar (Fig. 159)

1. *Glyptotermes arshadi* Chaudhry and Ahmad :

1972. Chaudhry and Ahmad, *Termites of Pakistan, Final Tech. Rept. PL 480 Proj No. A 17-F.S.-12*: vii, 3 (Nom. Nud.).

2. *Glyptotermes arshadi* Akhtar :

1975. Akhtar, *Bull. Dept. Zool. Univ. Panjab (N.S.)*, Art. 7: 15-17, 190, Soldier. Holotype : Soldier, in Dept. of Zoology, Panjab Univ., Lahore. *Type-locality*: Adampur (Bangladesh).

IMAGO Unknown.

**SOLDIER (Fig. 159) :** Head-capsule brown at frons, paler posteriorly; postclypeus brown, anteclypeus yellowish brown; labrum pale brown; mandibles pale reddish brown, blackish anteriorly; antennae brownish yellow; pronotum brownish yellow; legs and abdomen pale. Head sparsely hairy; labrum with a few bristles on anterior margin and on body. Head longer than broad, length to base of mandibles 1.13-1.23, width 0.80-0.88 mm; sides parallel, posterior margin round; frons slightly sloping, weakly bilobed; Y-suture absent; anterolateral corners of head sharply pointed. Eyes indistinct. Antennae with 9 to 10 segments; in specimens with 10 segments, 2 one-and-a-half times as long as 3; 3 shortest; in 9 segmented ones, 2 and 3 subequal. Labrum a little wider than long, sides weakly convex, anterior margin broadly rounded. Mandibles long (0.61-0.63 mm) and thin, head-mandibular index 0.51-0.54; basal humps weak. Left mandible with three

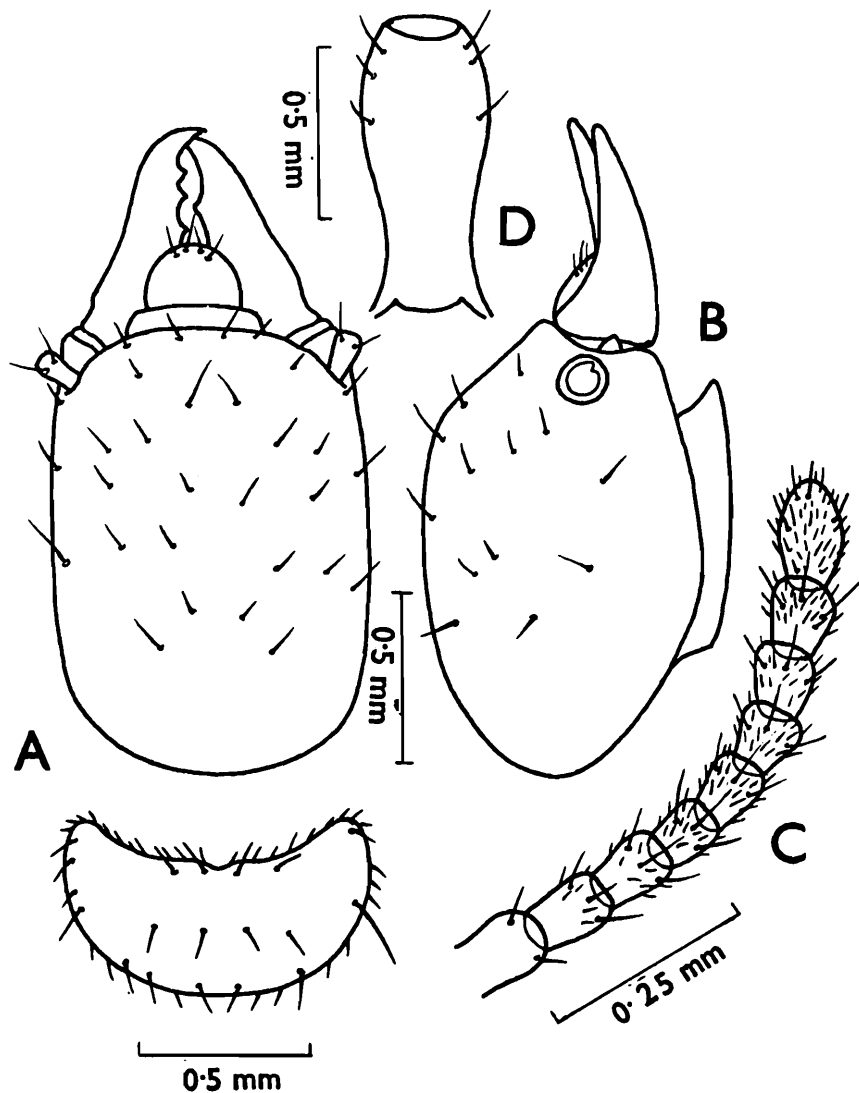

Fig. 159. *Glyptotermes arshadi*. Soldier. (A) Head and pronotum, in dorsal view. (B) Head, in side view. (C) Antenna. (D) Postmentum. (After Akhtar, 1975).

and right mandible with two marginal teeth. Postmentum long, club-shaped, widest in anterior half; length 0.65-0.67, maximum width 0.32-0.35, width at waist 0.17-0.20 mm. Pronotum half-moon-shaped; length 0.30-0.32, width 0.73-0.83 mm; anterior margin moderately concave, lateral sides weakly convex; posterior margin convex. Legs with 3:3:3 apical tibial spurs.

**Distribution :** BANGLADESH : Adampur (type locality).

*Biology* : This species is reported (Chaudhry and Ahmad, 1972) from a rotten log in the interior of thick rain forest in Bangladesh, making irregular, longitudinal galleries, and also from outer portion of *Eugenia* sp. log. The galleries are inter-connected by triangular holes.

### 36. *Glyptotermes ceylonicus* Holmgren (Figs. 160, 161)

*Calotermes (Glyptotermes) ceylonicus* Holmgren :

1911. Holmgren, in Escherich's *Termitenleben auf Ceylon*: 187-189. Imago. Holotype : Imago, in Mus. Vienna. *Type-locality* : Peradeniya (Sri Lanka).

*Glyptotermes ceylonicus* Holmgren :

1949. Snyder, *Smiths. misc. Colls.*, **112**: 47 (see for other references also).

1970. Roonwal, In *Biology of Termites* (ed. Krishna and Weesner) Vol. 2: 325.

1975. Chhotani, *Rec. zool. Surv. India*, **68**: 113, 117, 128-139, 150, 157 (see for other references also).

1975. Chhotani, *Zool. Anz.*, **194**: 118.

1980. Chhotani, *Tech. Monogr. Zool. Surv. India*, No. 4: 4, 12, 20-21.

1985. Chhotani and Bose, *Rec. zool. Surv. India*, **82**: 56.

**IMAGO** Head pale brown, paler in front (yellowish brown to brown). Pronotum paler than head. Abdomen brownish above, paler below; legs rust yellow. Wings iridescent, with brownish anterior veins. Pilosity of head and thorax very thin. Total length with wings 8.5-11.0, without wings 4.7-6.0 mm. Head thick, almost quadrately oval; length 1.33-1.52, width 1.15-1.30 mm. Eyes and ocelli small, ocelli separated from the eyes by their diameter or a little more [touching the eyes vide Holmgren 1913]. Clypeus short. Antenna 13 to 14-segmented, distinctly thickened distally; segment 2 almost as long as 3. Pronotum narrower than to almost as wide as head posteriorly; anterior corners acutely rounded, posterior corners strongly rounded, posterior margin hardly sinuate; longer than half width (length 0.52-0.72, width 0.96-1.22 mm). Wings moderately long (forewing 7.3 mm), narrow, marked, weakly iridescent; subcosta not visible; radius fusing with anterior margin before middle of wing; radial sector single; media running near radial sector; transverse branches absent; cubitus only basally strongly marked, with generally 10-13 branches.

**SOLDIER (Fig. 160)** Head-capsule brownish yellow, frons reddish brown; labrum and antennae pale yellow to reddish yellow; mandibles black; body and legs straw yellow. Head sparsely and body moderately hairy; mandibles with short hairs at basal humps. Total body length c 6.5-10.4 mm. Head-capsule subrectangular, length a little less than twice width (length to base of mandibles 2.67-3.00, width 1.5-1.67 mm); sides subparallel or faintly incurved medially; antero-dorsal protuberances at base of frons fairly prominent; Y-suture present. Eyes oval, translucent; situated behind antennae at less than their long diameter. Ocelli small, dot-like, situated at end of lateral arms of Y-suture. Antennae with 12 segments; segment 2 about half of 1 or a little longer; 3 shortest. Clypeus divided into anteclypeus and postclypeus; anteclypeus apilose, translucent, rectangular, strip-like; postclypeus pilose, of same colour as frons and demarcated from frons at lateral corners. Mandibles thick, stout, and short (0.90-1.00 mm long); broadly narrowed at tips. Left mandible with 2 large, broad marginal teeth; 1st marginal situated at about one-fourth from distal tip or closer to tip; 2nd broader and situated medially or just below 1st. Right mandible also with 2 medially situated marginals. Postmentum long (1.90-2.33 mm), club-shaped; widest (0.5-0.6 mm) anteriorly at one fourth; waist long and narrow, minimum width of waist (0.23 mm) less than half to about half of maximum width. Pronotum flat, subrectangular, either narrower or as wide as head (length 0.73-0.97, width 1.33-1.67 mm); anterior margin incurved and with a faint median notch; posterior margin weakly invaginated medially or notched. Mesonotum narrower or as wide as and metanotum narrower to a little wider than, pronotum; both weakly incurved medially at posterior margin. Legs thick, stout and hairy; apical tibial spurs 3:3:3. Abdomen oblong; cerci 2 jointed; styli single-jointed.

**PSEUDOWORKER (Fig. 161)** Head-capsule pale yellow; antennae, labrum, legs and body paler. Head and body moderately hairy. Total body length 8.6 mm. Head-capsule subcircular, a little broader (1.5 mm) than its length to base of mandibles (1.40 mm). Eyes translucent, round. Ocelli absent. Antennae with 8 + segments; segment 3 shortest. Clypeus flat, trapezoidal, not clearly divided into ante- and postclypeus. Labrum broadly tongue-shaped (length 0.47, width 0.43 mm); hairy near anterior margin and on body. Mandibles typically *Glyptotermes*-type. Pronotum flat, subrectangular (length 0.90, width 1.60 mm); wider than head; anterior

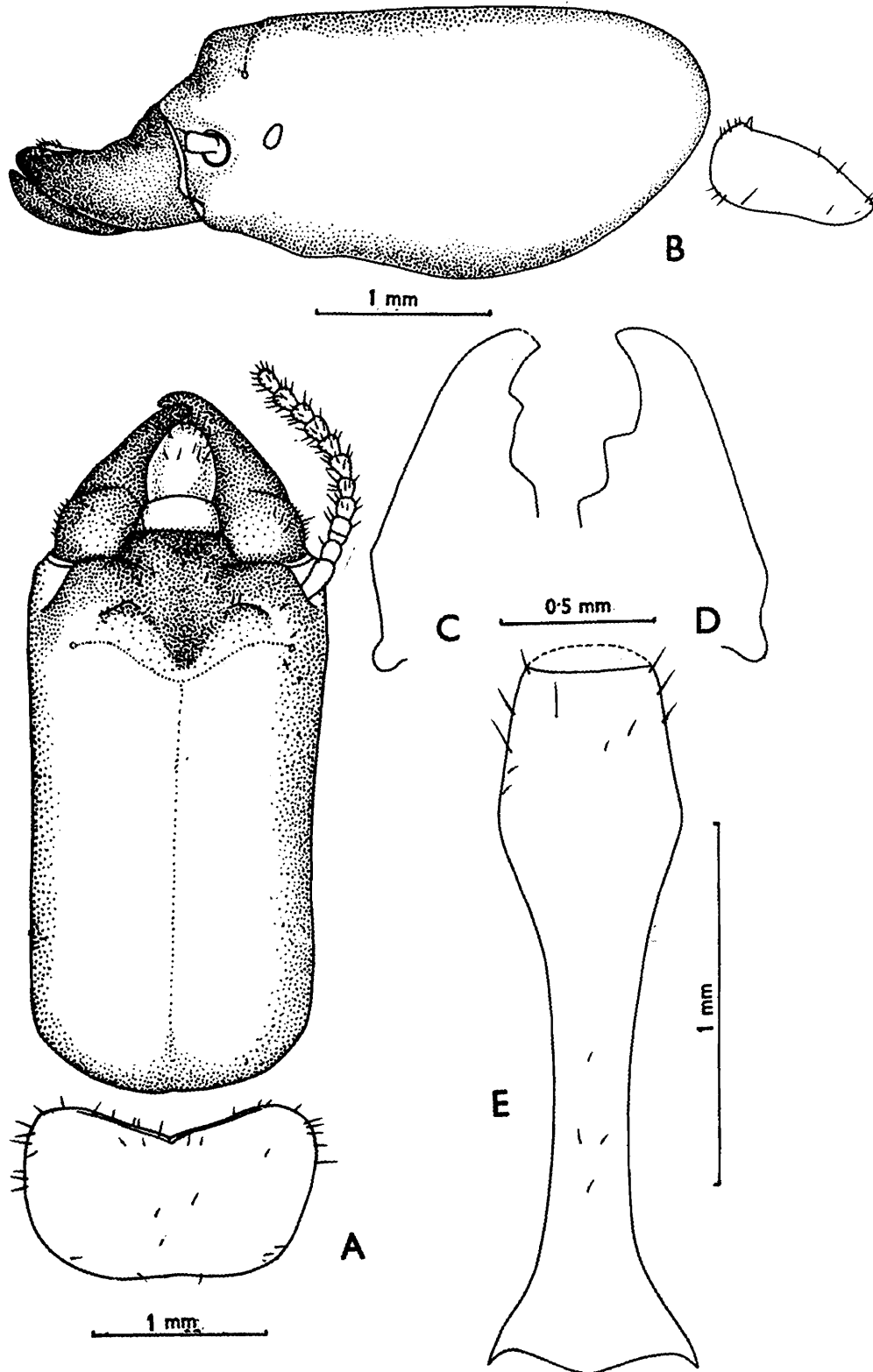

Fig. 160. *Glyptotermes ceylonicus*. Soldier. (A) Head and pronotum, in dorsal view. (B) Same, in side view. (C) and (D) Left and right mandibles. (E) Postmentum. (After Chhotani 1975a).

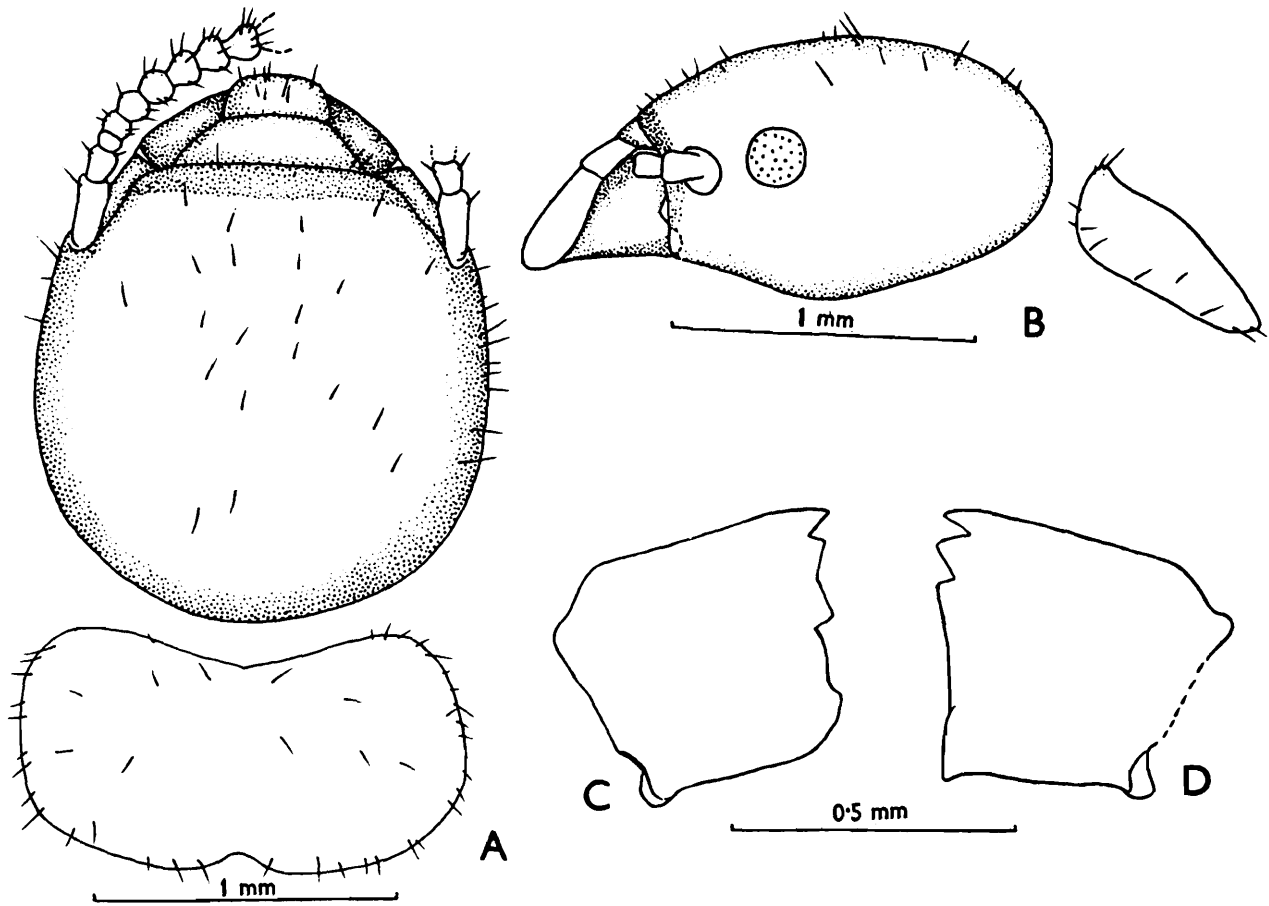

Fig. 161. *Glyptotermes ceylonicus*. Pseudoworker. (A) Head and pronotum, in dorsal view. (B) Same, in side view. (C) and (D) Left and right mandibles. (After Chhotani 1975a).

margin incurved, with a medial notch; posterior margin broadly notched medially. Abdomen and legs as in soldier.

**Distribution :** This species is restricted to Sri Lanka and is reported from Chilaw, Hewaheta, Elpitiya, Kurunegala, Pasara and Peradeniya.

**Biology :** This is not a very common species in Sri Lanka and is reported from dead, decaying logs and branches of *Hevea*, *Acacia*, *Artocarpus integrifolia* and some unknown species and also attacks living trees. The nest is in the form of longitudinal galleries.

**37. *Glyptotermes coorgensis* Holmgren and Holmgren**  
 (Synonym *Glyptotermes nigrifrons* Mathur & Sen-Sarma)  
 (Figs. 162-165)

1. *Calotermes (Glyptotermes) coorgensis* Holmgren & Holmgren :

1917. Holmgren and Holmgren, *Mem. Dept. Agric. India*, 5(3): 139-140. Soldier. Holotype not designated; syntypes probably in Holmgren Coll. at Naturhist. Riksmuseet, Stockholm; one soldier and several Nymphs in AMNH, New York and one pseudoworker FRI, Dehra Dun. *Type-locality* : Sidapur, Coorg (Karnataka State, India).

2. *Glyptotermes coorgensis* Holmgren & Holmgren :

1975. Chhotani, *Rec. zool. Surv. India*, 68: 113, 117, 118, 124, 127, 134-142, 157 (see for other references also).

1975. Chhotani, *Zool. Anz.*, 194: 118.

1984. Bose, *Occ. Pap. Rec. zool. Surv. India*, No. 49: 16, 53-56.

3. *Glyptotermes nigrifrons* Mathur and Sen-Sarma:

1960. Mathur and Sen-Sarma, *Entomologist*, 1960: 77-85.

1975. Chhotani, *Rec. zool. Surv. India*, 68: 110, 111, 113, 114, 118, 155-157.

1984. Bose, *Occ. Pap. Rec. zool. Surv. India*, No. 49, : 52, 53, 54, 56.

1985. Verma, *Indian J. For.*, 8(3): 176.

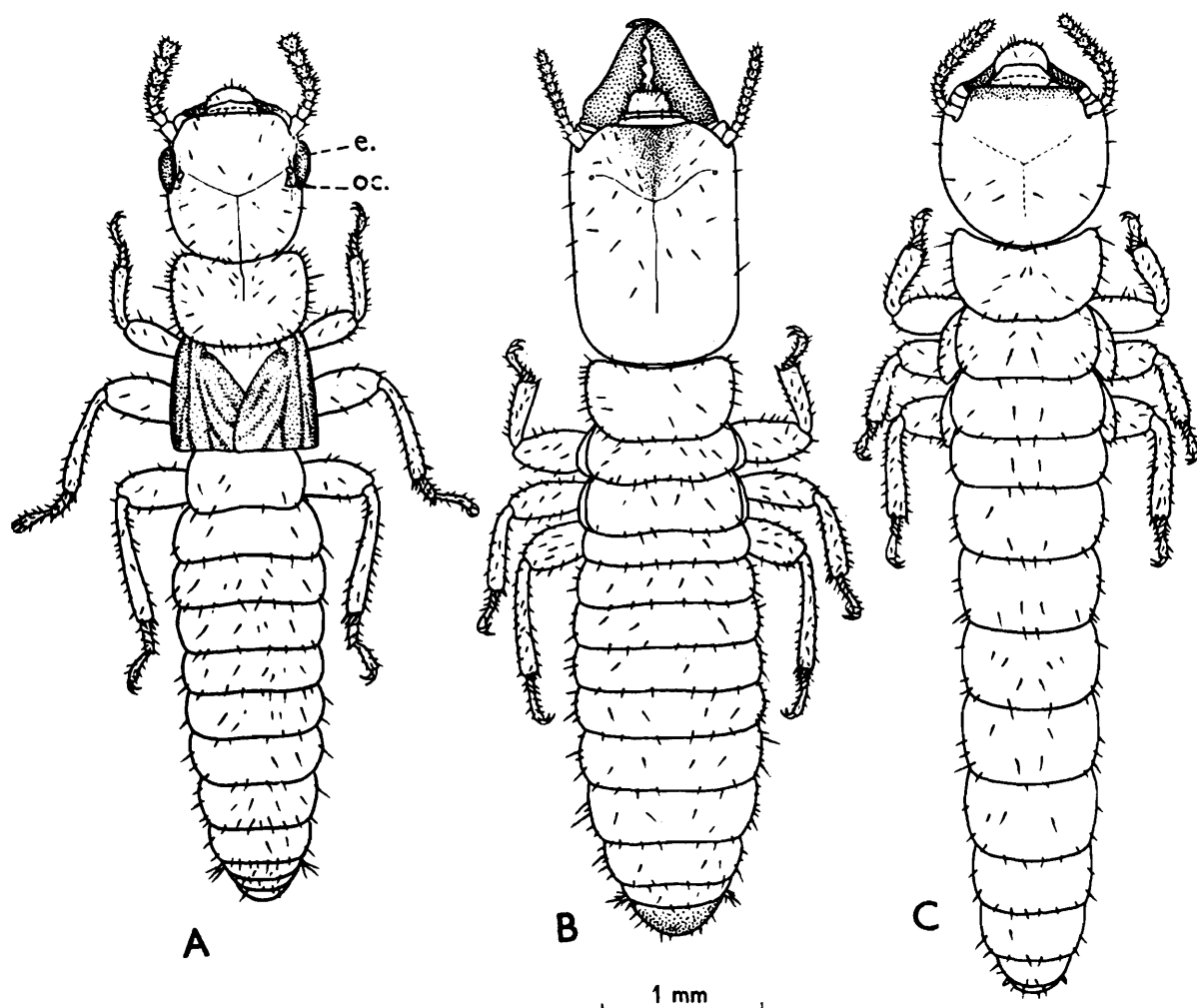

Fig. 162. *Glyptotermes coorgensis*. (A) Imago (B) Soldier. (C) Pseudoworker. e., eye; oc., ocellus. (After Chhotani, 1975a).

IMAGO (Figs. 162-164) : Head-capsule dark castaneous brown; labrum and legs brownish; antennae a little darker; thorax and abdomen a little paler than head; abdominal sternites paler than tergites, basal 4 sternites pale yellowish medially. Head and body fairly pilose. Total body-length with

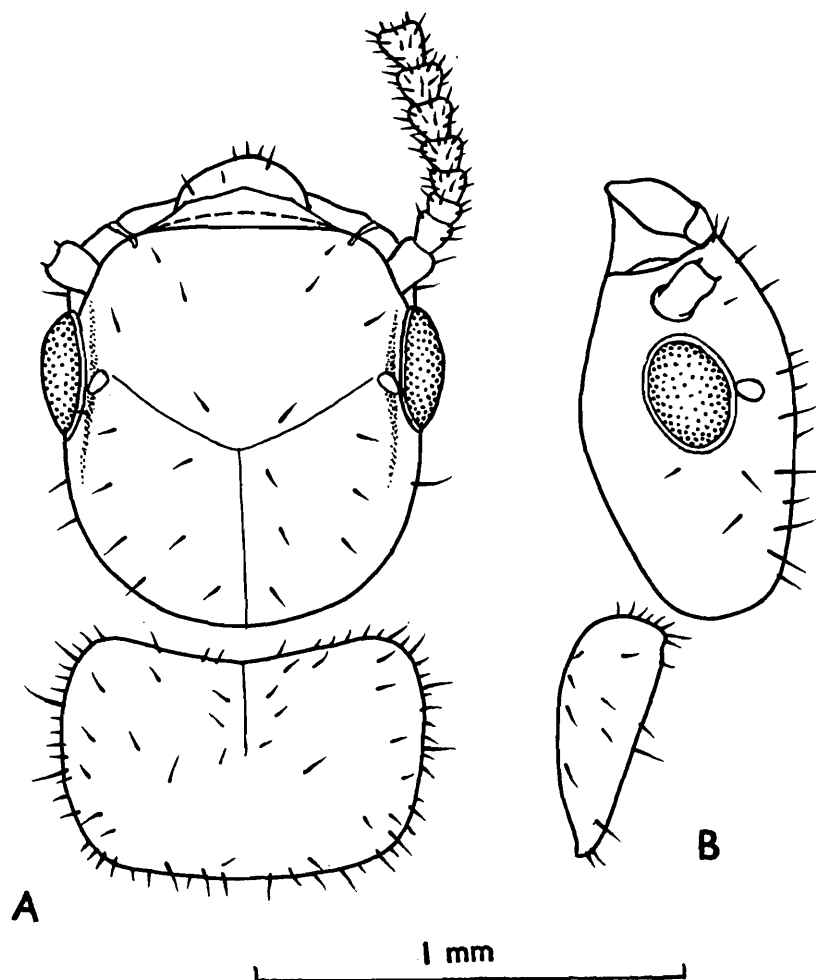

Fig. 163. *Glyptotermes coorgensis*. Imago. (A) Head and pronotum, in dorsal view. (B) Same, side view. (Redrawn from Chhotani, 1975a).

wings 6.40-6.70, without wings 4.00-4.70 mm. Head-capsule subsquarish (length to base of mandibles 0.87-0.90, width 0.85-0.93 mm); Y-suture present. Eyes oval (long-diameter 0.25 mm), black, separated from lower margin of head by less than their short diameter. Ocelli small, oval (0.07 mm long, 0.05 mm wide), translucent, touching the eyes and directed vertically in lateral view. Antennae with 11-12 segments; segment 2 about half of 1, 3 slightly shorter than 2. Clypeus subtrapezoidal, indistinctly divided into ante- and postclypeus; anteclypeus apilose, medially weakly projected in front; postclypeus with a few, short hairs near posterior margin.

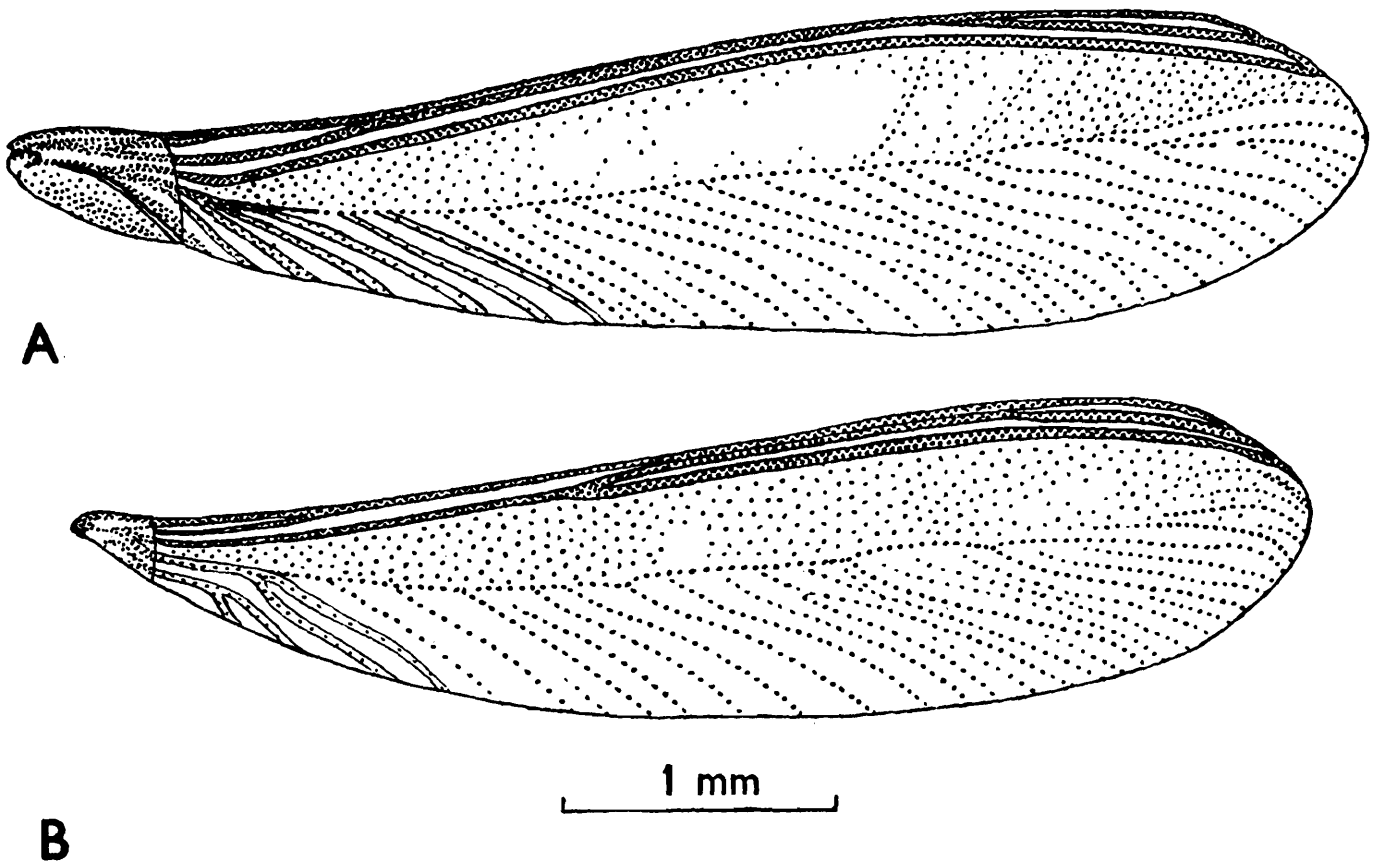

Fig. 164. *Glyptotermes coorgensis*. Wings. (A) Right forewing. (B) Right hindwing. (After Bose, 1984).

Labrum broader than long (length 0.23, width 0.33 mm); with a few hairs near anterior margin and on body. Mandibles typically *Glyptotermes*-type. Pronotum subrectangular, slightly narrower than head with eyes (length 0.50-0.57, width 0.80-0.83 mm); anterior margin weakly concave, posterior margin substraight. Legs short, hairy; apical tibial spurs 3:3:3; arolium present. Wings pale brown; forewing 4.9-5.0 and hindwing 4.6-4.75 mm long; with minute, pimple-like markings (tubercles); all veins except cubitus thick and chitinised. Radius meeting costa at proximal 1/6 of wing in forewing and at proximal 1/4 in hindwing. Abdomen oblong, sparsely hairy.

**SOLDIER**(Figs. 162, 165): Head-capsule reddish yellow, reddish brown anteriorly and somewhat paler posteriorly; antennae yellow to pale brown; labrum pale brown; thorax and abdomen yellowish to pale reddish yellow, pronotum somewhat darker; last abdominal tergite weakly to strongly more

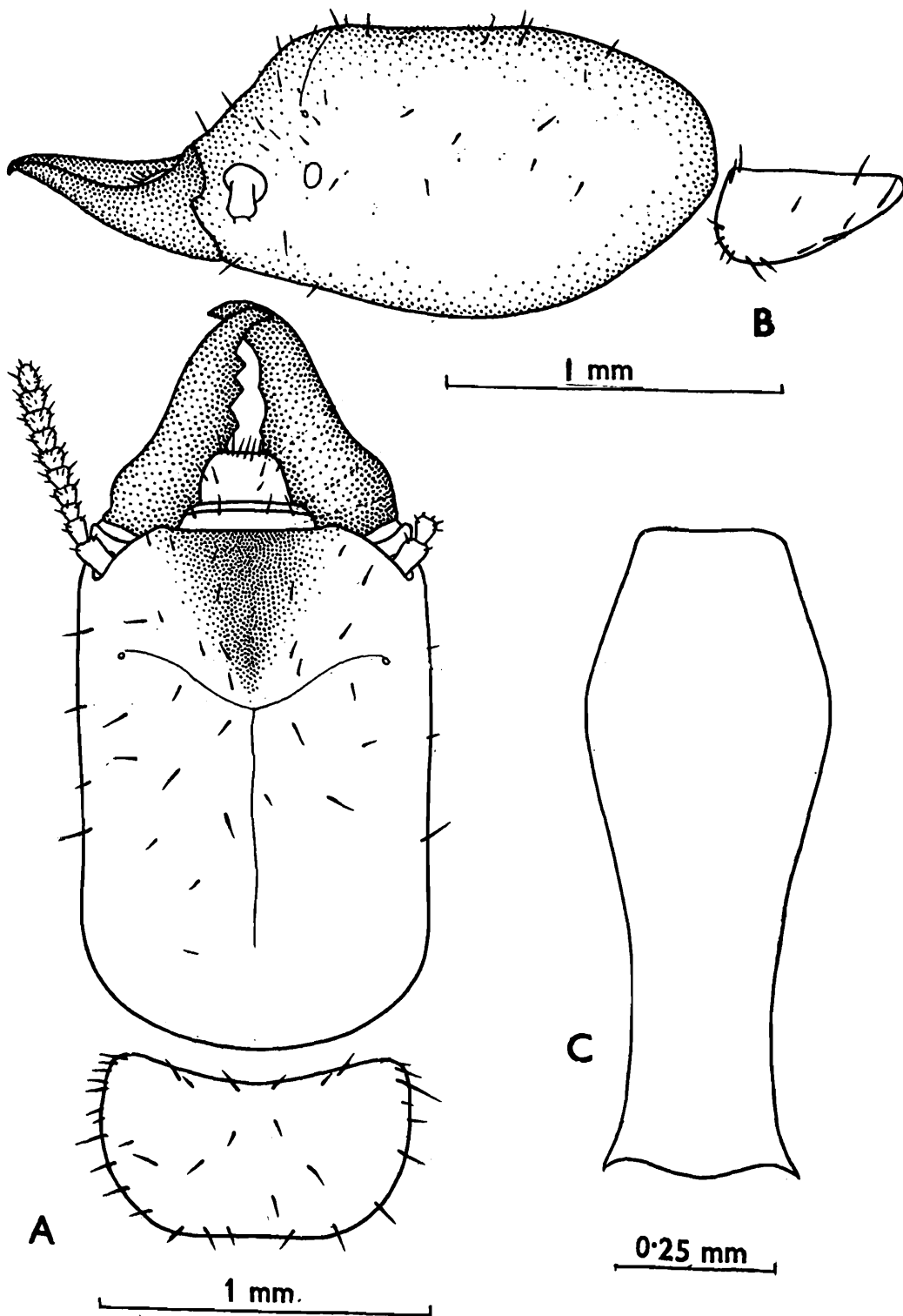

Fig. 165. *Glyptotermes coorgensis*. Soldier. (A) Head and pronotum, in dorsal view. (B) Same, in side view. (C) Postmentum. (After Chhotani, 1975a).

chitinised than preceding-ones. Head and body sparsely hairy. Total body-length 4.20-6.00 mm. Head-capsule subrectangular (length to base of mandibles 1.33-1.70, width 1.00-1.20 mm); frons bilobed sloping in front at about 45° and depressed medially; Y-suture distinct; antero-lateral corners sharply projected in front. Eyes oval, unpigmented. Ocelli minute, dot-like, each situated at end of lateral arm of Y-suture. Antennae with 9-11 segments; segment 2 about 1/2 of 1; 3 variable, either short, or subequal to or longer than 2, sometimes subdivided into two. Clypeus subtrapezoidal; anteclypeus pale brown, apilose, either shorter than or as long as postclypeus; postclypeus as dark as frons and pilose, separated from frons by a thin groove. Labrum broadly tongue-shaped (length 0.13-0.23, width 0.27-0.30 mm); pilose near tip and on body. Mandibles short, 0.63-0.77 mm long; less than half of head without mandibles; outer margin near base with a weak to prominent hump. Left mandible with 3 marginal teeth, 1st and 2nd close together, 3rd widely separated by a curved and notched margin and larger; right with 2 small marginals in middle-third. Postmentum long, club-shaped; waist long, narrowest behind the middle; length 0.83-1.17, max. width 0.35-0.44 and width at waist 0.19-0.27 mm. Pronotum subrectangular, length 0.5-0.6, width 0.87-1.05 mm; narrower than head; anterior margin fairly incurved; posterior margin rounded or sometimes faintly incurved medially. Mesonotum narrower and metanotum wider than pronotum, both having slightly invaginated posterior margins. Legs short and hairy; apical tibial spurs 3:3:3. Abdomen oblong; 10th tergite slightly to strongly sclerotised; cerci short, 2 segmented; styli single-jointed.

**PSEUDOWORKER (Fig. 162) :** Head-capsule pale yellow to pale reddish yellow; antennae, labrum and legs paler; body creamish white, pronotum slightly chitinised. Head and body fairly pilose. Total body-length 4.90-6.20 mm. Head-capsule subcircular (length to base of mandibles 0.90-1.07, width 0.93-1.10 mm). Eyes unpigmented; sometimes not discernible. Antennae with 10-11 segments; segment 3 as long as or shorter than 2. Clypeus, labrum and mandibles as in imago. Pronotum subrectangular, length 0.53-0.70, width 0.83-1.00 mm, narrower than head; anterior margin incurved; posterior margin slightly incurved medially. Legs and abdomen as in soldier.

**Distribution :** This species is fairly well distributed in southern India and is recorded from the following localities: India : Karnataka: Anekad Forest Range (Coorg), Janserigoda (Bababudin Hills, Chickmagalur Dist.), Sidapur (Coorg, type-locality). Tamil Nadu : Mylar (Kulasekarum Forest Range, Nagarcoil district), Top Slip (nr Pollachi). Kerala Sholary.

**Biology :** The nests of this species have been found in dead portions of *Ficus religiosa* Linn., red cedar and Silver oak trees; slowly and slowly the nest is extended to the adjoining living portions also. The galleries and chambers are filled with blackish masses of faecal matter. The termite has also been collected from dead logs of unknown plants lying on the ground.

### 38. *Glyptotermes dilatatus* (Bugnion and Popoff) (Figs. 166, 167)

#### 1. *Calotermes dilatatus* Bugnion & Popoff :

1910. Bugnion and Popoff, *Mem. Soc. Zool. Fr.*, 23: 137-147, text fig. 13 (Soldier), pl. 4, Soldier, Nymph, Larva), Holotype; Repository not known. Type-locality: Ambalangoda, Sri Lanka.

#### 2. *Glyptotermes dilatatus* (Bugnion & Popoff)

1932. Hutson, *Adm. Rep. Dir. Agric. Ceylon*, 1931: 114-115.

1949. Snyder, *Smiths. misc. Colls.*, 112: 47 (see for other references also).

1962. Fernando, In *Termites Humid Tropics* (Proc. New Delhi Symp., 1960): 205, 208.

1970. Roonwal, In *Biology of Termites* (ed. Krishna and Weesner) Vol. 2: 327.

1975. Chhotani, *Rec. zool. Surv. India*, 68: 109, 110, 113, 117, 134, 142-150, 157 (see for other references also).

1975. Chhotani, *Zool. Anz.*, 194: 118.

1980. Chhotani, *Tech. Monogr. Zool. Surv. India*, No. 4: 4, 19, 21-22.

**IMAGO** (Fig. 166) Head-capsule brownish yellow; antennae, labrum, legs and body paler than head. Head and body sparsely hairy. Total length with wings 10.0-10.5, without wings 4.3-6.0 mm. Head-capsule subcircular, with eyes wider (1.03-1.28 mm) than its length to base of mandibles (1.00-1.17 mm); sides without eyes weakly convex. Eyes medium sized, subcircular (max. diameter 0.37-0.43 mm); separated from lower margin of head by half its short diameter. Ocelli oval (length 0.13, width 0.10 mm),

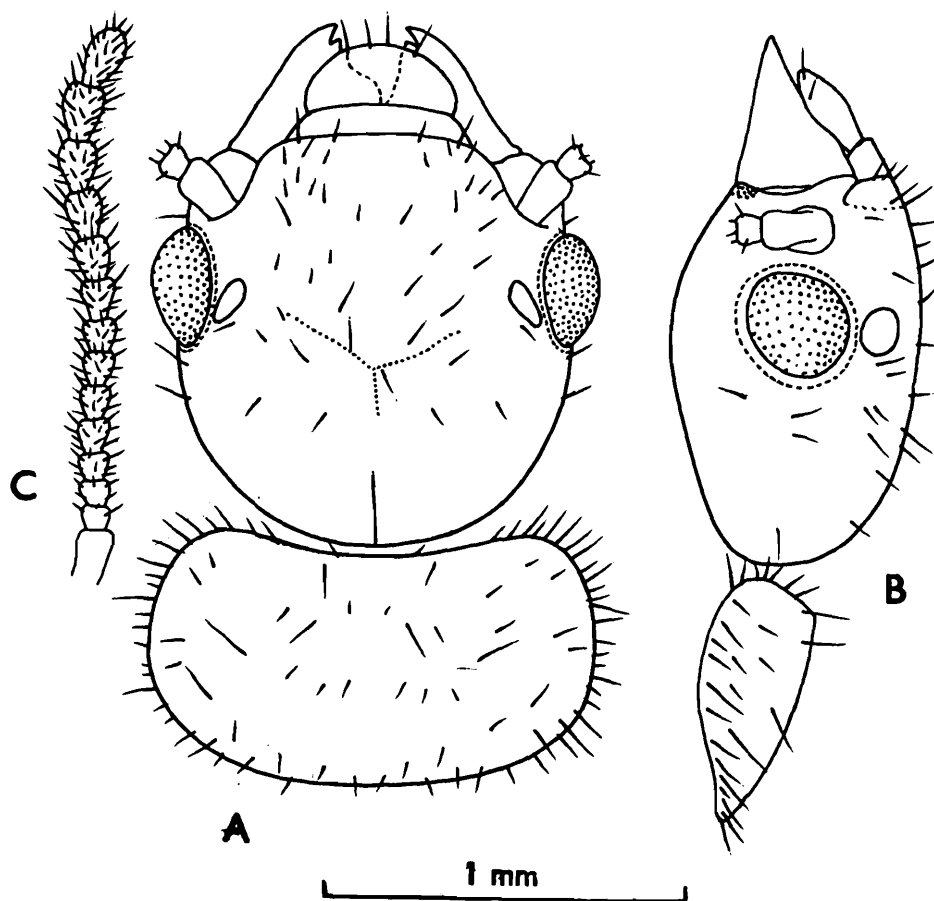

Fig. 166. *Glyptotermes dilatatus*. Imago. (A) Head and pronotum in dorsal view. (B) Same in side view. (C) Antenna.

translucent, only faintly separated from or touching the eyes. Antennae with 13-15 segments; segment 3 variable, either equal to or shorter than or longer than 2 or 4. Clypeus flat, subtrapezoidal; anteclypeus strip-like, apilose, hyaline; postclypeus pale yellow, anteriorly weakly convex. Labrum broad, tongue-shaped, broader than long, length 0.30 width 0.37-0.43 mm; hairy near anterior margin. Mandibles typically *Glyptotermes*-type. Pronotum flat, subrectangular, length 0.70, width 1.0-1.13 mm; narrower than to as wide as head with eyes; anterior margin fairly deeply incurved, medial notch not distinct; posterior margin weakly outcurved, without any notch or medial invagination. Mesonotum and metanotum with weakly convex to substraight posterior margin. Legs short, thick and pilose; apical tibial spurs 3:3:3; arolium present. Wings as in genus except as follows : Forewing

Radius short, meeting costa between one-fifth to one third of wing-membrane; cubitus with a number of vague branches. Hindwing; Radius meeting costa at about one-seventh of wing-membrane; cubitus as in forewing. Abdomen oblong; cerci 2-jointed; styli (in male) single-jointed.

**SOLDIER (Fig. 167)** Head-capsule yellowish brown to brownish red, darker anteriorly; antennae, labrum, thorax, and body straw yellow to yellowish brown; mandibles black. Head and body sparsely hairy. Total length 5.90-8.00 mm. Head-capsule subrectangular (length to base of mandibles 2.03-2.33, width 1.30-1.37 mm); frons sloping in front sharply, bilobed, fairly deeply depressed medially and with two prominent protuberances at base of slope; sides substraight; Y-suture distinct. Eyes small, oval, 0.13 mm long, unpigmented; situated a little behind antennal sockets. Ocelli small, dot-like; each situated near the end of lateral arm of Y-suture. Antennae with 11-13 segments, segment 1 strongly chitinised; 3 slightly longer or shorter than 2. Clypeus divided into ante- and postclypeus; anteclypeus thin, strip-like, apilose; postclypeus not distinctly separated from frons, weakly pilose. Labrum broadly tongue-shaped, either longer or shorter than wide (length 0.20-0.37, width 0.33-0.37 mm). Mandibles long and fairly strong, 1.03-1.13 mm long; left with 4 marginal teeth of variable size; right with 2 large, medial, marginal teeth. Postmentum long, club-shaped; club weakly bilobed; broadest anteriorly at one-fifth; waist long and narrow but shorter than in *ceylonicus*; length 1.5-1.6, max. width 0.40-0.50 and width of waist 0.2-0.23 mm. Pronotum flat, subrectangular; length 0.73-0.77, width 1.17-1.23 mm; narrower to wider than head; anterior margin fairly incurved, without median notch; posterior margin fairly outcurved and not notched medially. Mesonotum and metanotum narrower than pronotum, not notched posteriorly. Legs short and pilose; apical tibial spurs 3:3:3; tarsi 4-jointed. Abdomen oblong, hairy; cerci 2-jointed and styli single - jointed.

**PSEUDOWORKER** : Head-capsule straw yellow, rest of body pale. Sparsely pilose. Head-capsule subcircular; wider than its length to base of mandibles (length 1.03-1.17, width 1.10-1.23 mm). Eyes oval to round, rudimentary. Antennae with 11-12 segments; segment 3 shortest (12-segmented antenna), slightly longer than 2 (11-segmented antenna). Clypeus, labrum and mandibles as in imago. Pronotum flat, wider than

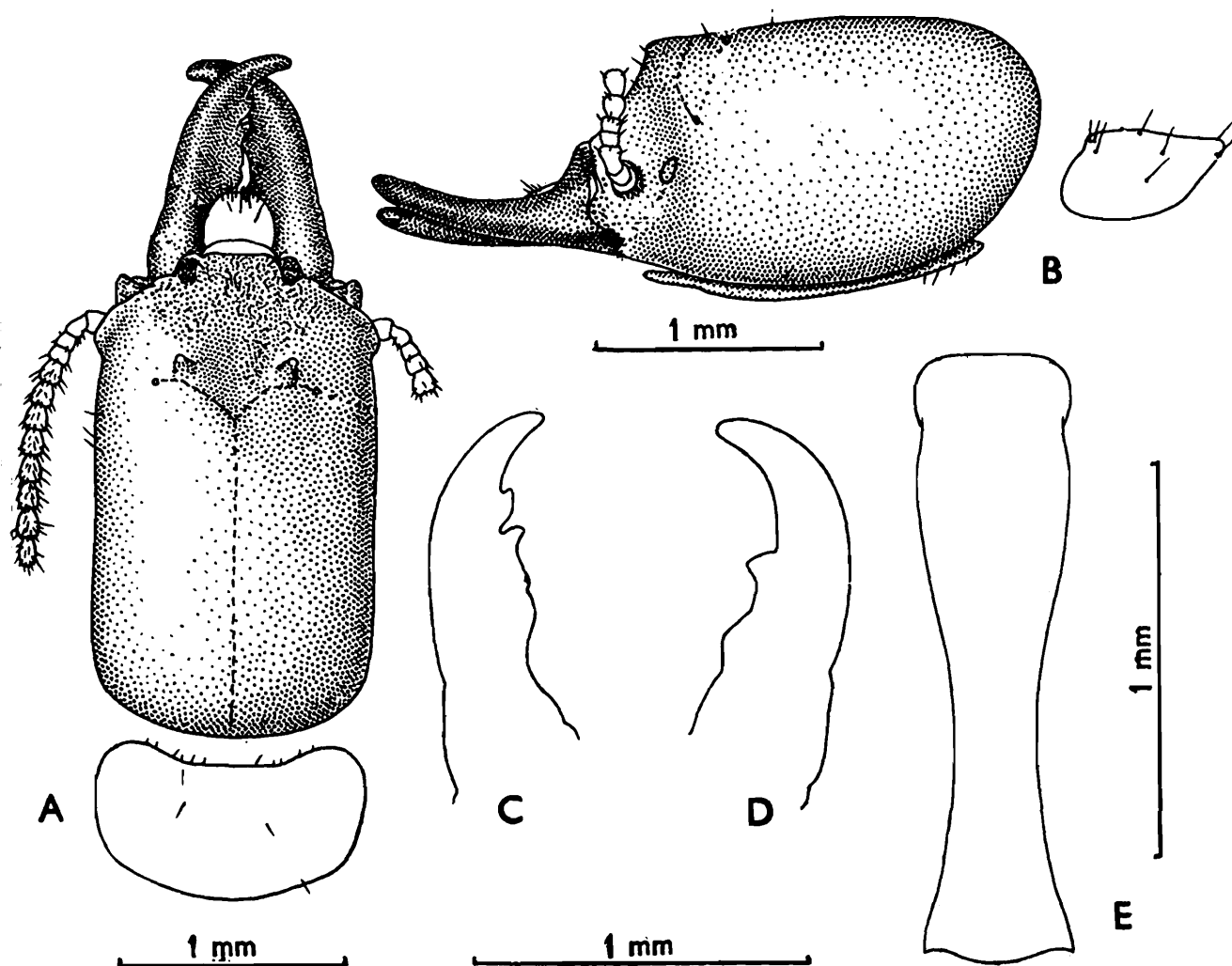

Fig. 167. *Glyptotermes dilatatus*. Soldier. (A) Head and pronotum in dorsal view. (B) Same, in side view. (C) and (D) Left and right mandibles. (E) Postmentum. (After Chhotani, 1975a).

head (length 0.60-0.70, width 1.23-1.40 mm); incurved at anterior and outcurved at posterior, margins. Legs and abdomen as in soldier.

*Distribution* : *Glyptotermes dilatatus* is restricted to and widely distributed in Sri Lanka; the Indian records are not correct. In Sri Lanka it is recorded from the following several localities : Ambalangoda, Avissawella, Balangoda, Chilaw, Deniyaya, Elpitiya, Galaha, Galle, Gampola, Horana, Ingiriya, Kadduganawa, Kandy District, Katugastata, Kegalla, Kelani Valley, Kiriella, Matugama, Opanake, Pelmadulla, Peradeniya, Ratnapura, Udugama and Yatiyantota.

*Biology and economic importance* : It is an important pest of tea below 610 m altitude in Sri Lanka and has been reported from several other plants including rubber, coffee and cocoa. The nest is in the form of longitudinal, inter-connecting galleries and tunnels in the heartwood, giving the wood a honeycomb appearance. The trees show very little evidence of the damage or attack externally. It takes nearly five years to produce winged adults if the colony is raised from eggs laid by neotenic pair (Bugnion, 1915; Pinto, 1941).

### 39. *Glyptotermes minutus* Kemner (Figs. 168, 169)

*Glyptotermes minutus* Kemner :

1932. Kemner, *Ent. Tidskr.*, 53: 149-150. Im and S. Lectotype : S, in Zoologiska Institute. Lund University. Lund. Sweden. *Type-locality* : Peradeniya. Sri Lanka. (Types examined).
1949. Snyder, *Smiths. misc. Colls.*, 112: 49.
1975. Chhotani, *Rec. zool. Surv. India*, 68: 109, 110, 113, 117, 118, 141-142. 150-155, 157 (see for other references also).
1975. Chhotani, *Zool. Anz.*, 194: 118.
1981. Maiti and Chakraborty, *Bull. zool. Surv. India*, 4(1): 83.

IMAGO ♀ (Lectomorphotype) (Fig. 168) : Head-capsule and body dark brown; labrum and antennae brownish yellow; clypeus yellow. Head and body sparsely hairy. Head-capsule subcircular, width with eyes (0.85 mm) more than length to base of mandibles (0.80); sides weakly convex and narrowed posteriorly. Eyes oval; max. diameter 0.25 mm; situated closer to basal margin of head than in other species. Ocelli oval, length 0.09, width 0.07 mm; situated horizontally and touching the eyes. Antennae incomplete, segment 3 subequal to 2. Clypeus indistinctly separated into ante- and postclypeus; anteclypeus translucent, apilose, substraight at anterior margin; postclypeus with a few short hairs and weakly convex at anterior margin. Labrum subsquarish, wider than long (length 0.20, width 0.29 mm); hairy near anterior margin and on body. Mandibles not examined. Pronotum subrectangular, length 0.49, width 0.73 mm; narrower than head-capsule with eyes; anterior margin incurved and faintly notched medially; posterior margin outcurved and with a weak medial

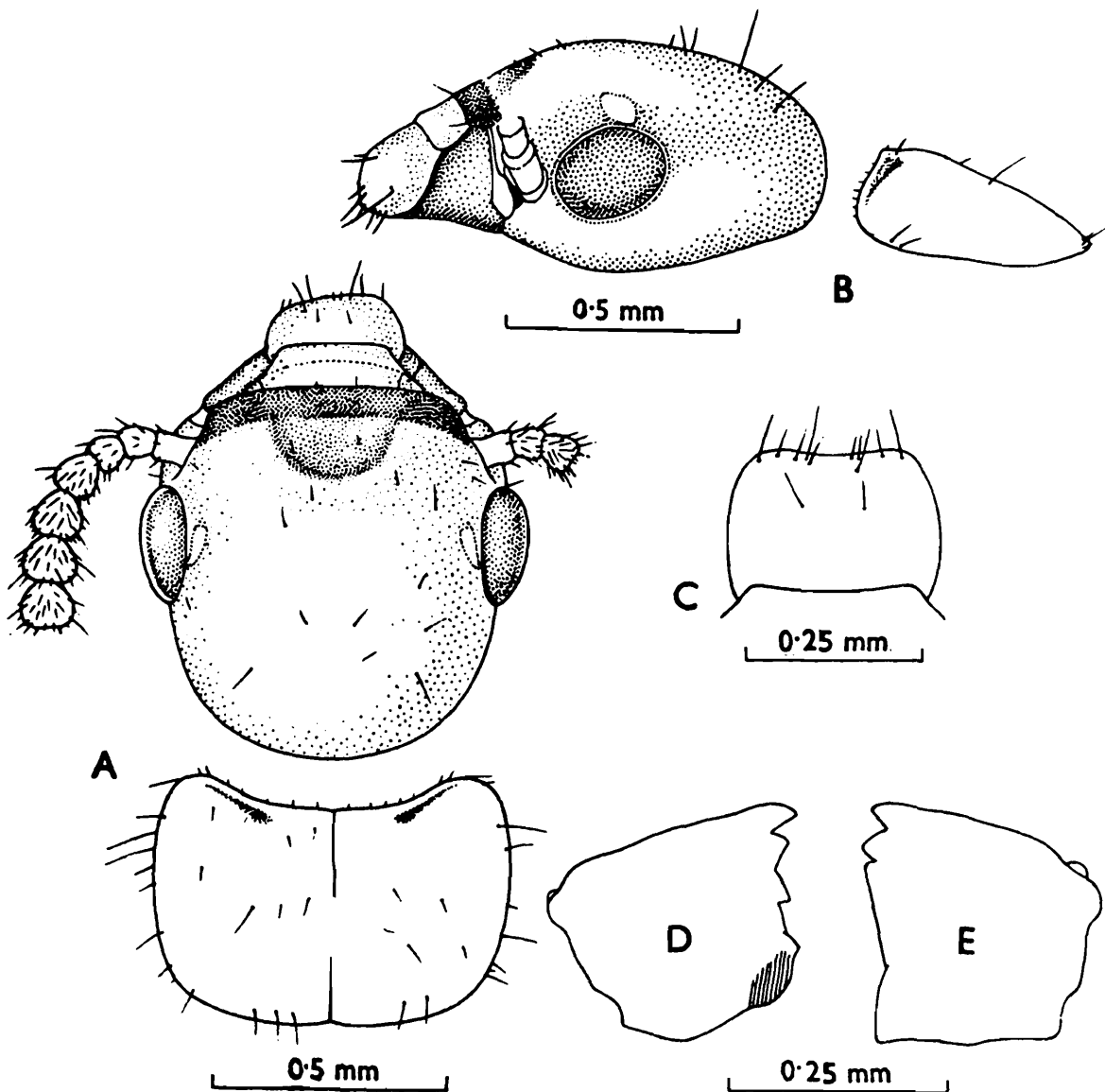

Fig. 168. *Glyptotermes minutus*. Imago (A-C) and Nymph (D, E). (A) Head and pronotum, in dorsal view. (B) Same, side view. (C) Labrum. (D) and (E) Left and right mandibles of nymph. (After Chhotani, 1975a).

notch. Mesonotum and metanotum incurved medially at posterior margin. Legs and wings broken in the specimen, only wing scales present; forewing scale large, shield-like, covering more than half of hindwing scale; hindwing scale short, triangular. Abdomen oblong, hairy; cerci present, 2-jointed; styli absent.

**SOLDIER (Lectotype) (Fig. 169) :** Head-capsule yellowish brown, anteriorly reddish brown; antennae, labrum and legs little paler than head;

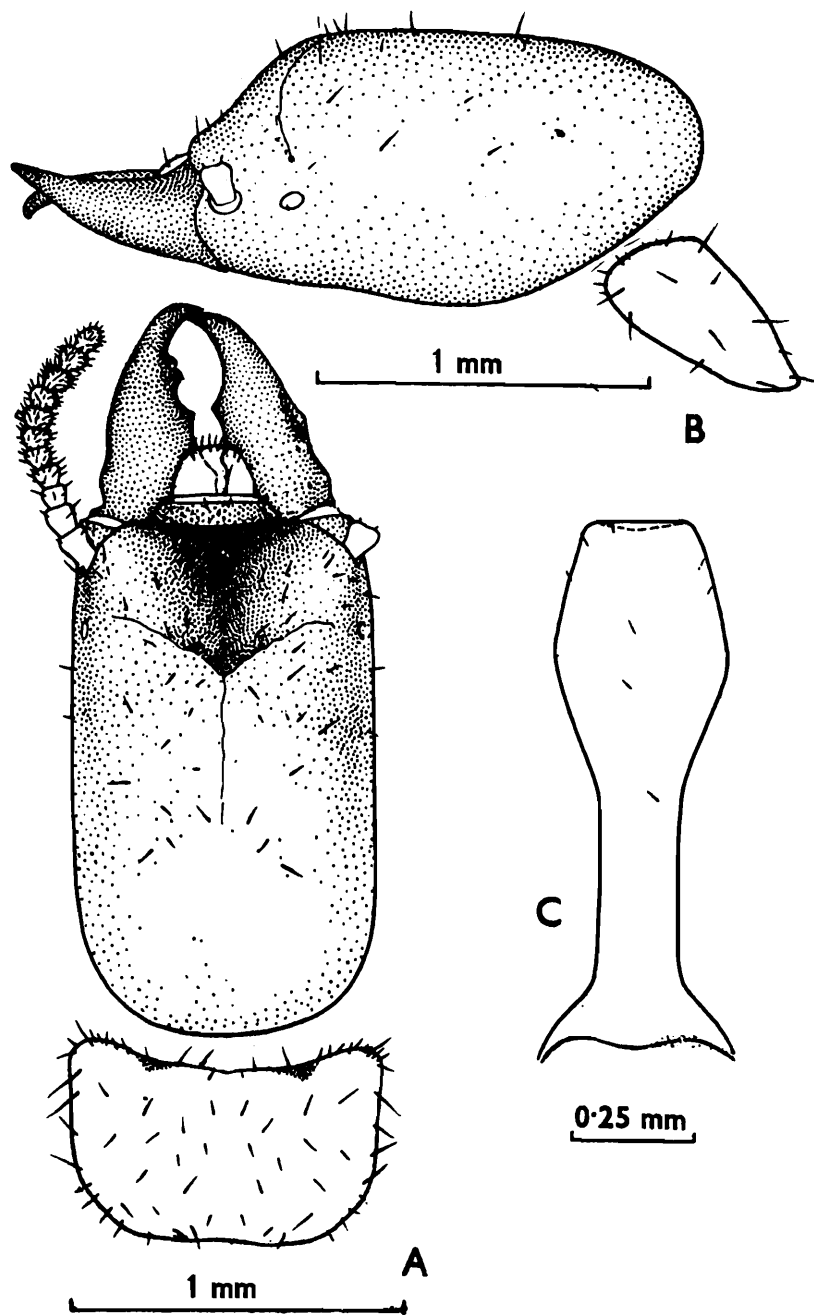

Fig. 169. *Glyptotermes minutus*. Soldier (lectotype). (A) Head and pronotum, in dorsal view. (B) Same, side view. (C) Postmentum (After Chhotani, 1975a).

mandibles black; pronotum yellowish brown, little darker than posterior portion of head and darker at anterior margin; abdomen pale yellowish brown. Head and body moderately pilose. Total length 4.1-5.1 mm. Head subrectangularly long, flat, length to base of mandibles 1.16-1.50, width 0.74-0.90 mm; frons gradually sloping at about  $45^\circ$  angle and somewhat

depressed medially; frontal protuberances at base of frons not present; antero-lateral corners rounded; Y-suture present. Eyes oval, small, spot-like (0.07 mm in diameter). Ocelli minute, hardly discernible. Antennae with 9-11 segments (9-10 *vide* Kemner, 1932); segment 2 about half of 1, 3 shortest or subequal to 2 or 4. Anteclypeus thin, apilose, strip-like; postclypeus with a few, short hairs and separated from frons by a thin groove. Labrum broadly tongue-shaped; broader (0.23 mm) than long (0.17 mm), much longer than broad *vide* Kemner, 1932; with a few short hairs near tip. Mandibles short, thick and strongly incurved at tip, length 0.70 mm; left mandible with 3 (2 *vide* Kemner, 1932) and right with 2, marginal teeth. Postmentum long, club-shaped; maximum width at distal one-fourth; waist long and narrower than half maximum width; length 1.07, max. width 0.37, width at waist 0.17 mm. Pronotum subrectangular, slightly broader than head (as broad as or narrower than head according to Kemner, 1932); length 0.60, width 0.93 mm; anterior margin incurved and with a weak median notch; sides substraight; posterior margin weakly outcurved, faintly incurved medially. Mesonotum narrower than and metanotum as wide as, pronotum; both somewhat incurved medially. Legs short and stout; apical tibial spurs 3:3:3. Abdomen oblong, hairy; last tergite more strongly chitinised than preceding ones; cerci 2-jointed; styli single-jointed.

**PSEUDOWORKER** Head-capsule pale yellowish brown, somewhat paler anteriorly; antennae, legs and body paler. Head and body moderately hairy. Total body-length 4.0 mm. Head-capsule subcircular, a little broader (0.77 mm) than length to base of mandibles (0.73 mm). Eyes hardly discernible (0.1 mm in diameter). Antennae 9-segmented, segment 2 longer than half of 1; 3 shorter than or as long as 2 and subdivided. Clypeus subtrapezoidal; anteclypeus hyaline, apilose; postclypeus pilose, convex anteriorly. Labrum subsquarish, length 0.20, width 0.23 mm; anteriorly weakly incurved medially. Mandibles typically *Glyptotermes*-type. Pronotum subrectangular (length 0.43, width 0.67 mm), flat, with a pair of median, brownish markings a little behind anterior margin; anterior margin incurved, with a weak median notch; anterior angles projecting in front; posterior margin with a weak median notch. Legs and abdomen as in soldier.

*Distribution* : This species is known only from Peradeniya, Sri Lanka.

*Biology* : *G. minutus* is reported from dead wood of rain tree *Samanea saman* and living *Cupressus knightiana*.

**40. *Glyptotermes nicobarensis* Maiti and Chakraborty**  
(Figs. 170, 171)

*Glyptotermes nicobarensis* Maiti & Chakraborty :

1981. Maiti and Chakraborty, *Bull. zool. Surv. India*, 4(1): 78-83. Im, S, Pw.  
Holotype : S, in ZSI, Calcutta. *Type-locality* : Laksman Beach, Campbell Bay,  
Rajendranagar, Great Nicobar Island, India.

IMAGO (Fig. 170) Head and body above chestnut brown; antennae, labrum, legs and sternites paler. Head and pronotum sparsely and abdomen

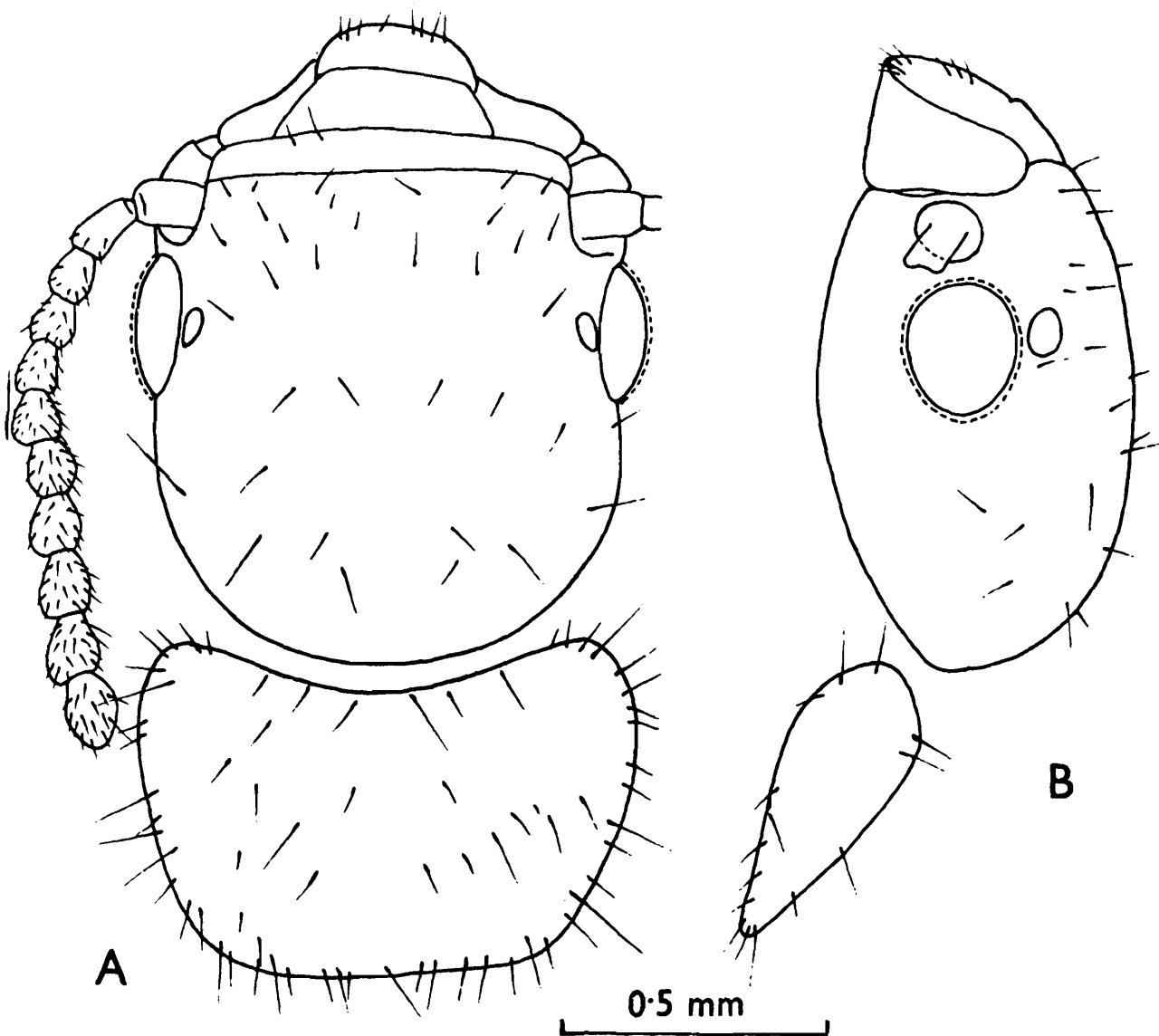

Fig. 170. *Glyptotermes nicobarensis*. Imago. (A) Head and pronotum, in dorsal view. (B) Same, in side view.

fairly densely hairy. Total body-length with wings 6.0-7.0, without wings 4.0-4.3 mm. Head capsule subcircular, almost as long as its width with eyes; length to base of mandibles 0.88-0.95, width with eyes 0.84-0.92 mm; epicranial sutures not discernible; sides without eyes faintly incurving at level of eyes; posterior margin round. Eyes medium sized, oval; situated at a distance of less than half of long diameter from lower margin of head; max. diameter 0.26 mm. Ocelli small, oval, 0.07-0.08 mm long and 0.05-0.07 mm wide; slightly separated from eyes. Antennae 11-segmented; segment 1 longest, cylindrical; 2 shorter than 1 and subequal to 3 and 4; 5 onwards gradually increasing in size and becoming pyriform; last ovate, shorter than penultimate. Clypeus subtrapezoidal; anteclypeus hyaline, strip-like, apilose; postclypeus faintly demarcated, depressed. Labrum broadly tongue-shaped, with a few hairs on body and anterior margin; length 0.23-0.26, width 0.26-0.30 mm. Mandibles typically *Glyptotermes*-type. Pronotum almost as wide as head; length 0.53-0.56, width 0.82-0.86 mm; anterior margin deeply incurved and without a median indentation; sides roundly converging behind; posterior margin weakly curved or substraight. Legs short, stout and pilose; tibial spurs 3:3:3; tarsi 4-jointed. Wings dark-brown, densely covered with tubercles. Forewing: subcosta short, meeting costa near scale; radius meeting costa at about 1/6 of wing-length; radial sector and media running upto distal tip, without any branches; cubitus with 11-12 branches to posterior border; otherwise venation as in genus. Hindwing Venation as in forewing except media arising from radial sector at proximal end outside wing-scale and cubitus with 12-13 branches. Abdomen oblong, sparsely hairy; cerci 2-segmented; styli in male, single-jointed.

**SOLDIER** (Fig. 171) : Head-capsule reddish brown, paler posteriorly; antennae, labrum and body pale yellowish brown; mandibles blackish. Head and body sparsely hairy. Total body-length 5.0-6.5 mm. Head-capsule subrectangular (length to base of mandibles 1.58-1.60, width 1.03-1.05 mm); frons gradually inclining in front at an angle of about 45°, smooth and faintly incurved; sides substraight, posterior margin rounded; Y-suture present; protuberances at base of frons weak. Eyes oval (0.14-0.19 mm long); situated close to antennae at a distance of less than their long diameter. Ocelli absent. Antennae with 10-12 segments; segment 1 long, cylindrical; 2 about half of 1; 3 small and thin, smaller than all others. Anteclypeus thin, strip-like, apilose; postclypeus, pilose not clearly

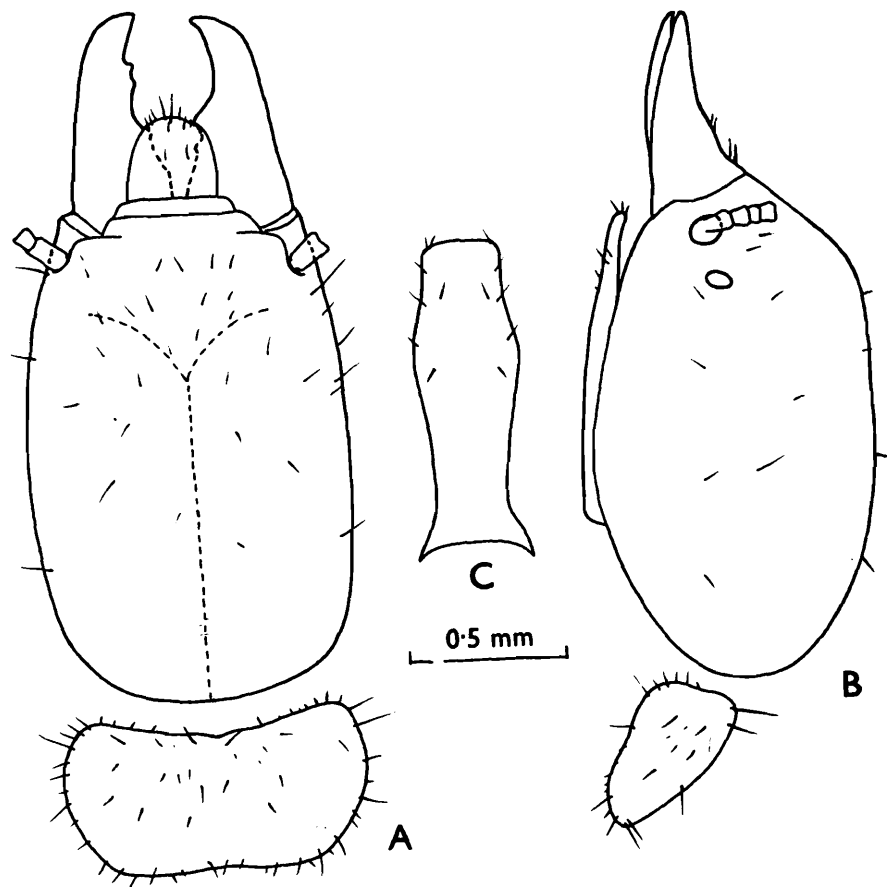

Fig. 171. *Glyptotermes nicobarensis*. Soldier. (A) Head and pronotum, in dorsal view. (B) Same, in side view. (C) Postmentum.

demarcated from frons. Labrum subsquarish (length 0.20-0.23, width 0.25-0.28 mm) with a round anterior margin. Mandibles thick and stout (0.61-0.69 mm long); less than half of head-length; left with 3 marginals, first and second lying close to each other at about distal third, third small, pointed, situated at proximal third and separated from second by a long incurved margin; right with 2 prominent marginals, first placed medially, second a little smaller than first and situated a little below it. Postmentum club-shaped; broadest at about anterior one-third; waist lying posterior to middle between widest point and posterior margin (length 0.95-1.11, max. width 0.30-0.37, width at waist 0.19-0.23 mm). Pronotum flat, almost as wide as head (length 0.53-0.61, width 0.95-1.03 mm); anterior margin broadly and weakly incurved, with a faint median notch; posterior margin slightly incurved medially. Legs short, stout and pilose; tibial spurs 3:3:3; tarsi 4-jointed. Abdomen elongate, hairy; cerci 2-jointed; styli single-jointed.

**PSEUDOWORKER** : Head-capsule pale yellowish white; body creamish white. Head and body sparsely hairy. Total length 5.0-6.0 mm. Head-capsule subcircular, as wide as long; length to base of mandibles 0.76-1.00, width 0.78-1.00 mm. Eyes faintly marked, subcircular. Ocelli absent. Antennae with 9 segments, segment 2 longer than 3 and latter longer than 4. Labrum broadly tongue-shaped; with a few hairs near anterior margin and on body; length 0.16-0.23, width 0.26-0.30 mm. Mandibles typically *Glyptotermes*-type. Pronotum a little narrower than head; length 0.38-0.57, width 0.65-0.88 mm; anterior margin substraight with a faint notch medially. Legs and abdomen as in soldier.

**Distribution** : INDIA Andaman and Nicobar Islands Laksman Beach, Campbell Bay, Great Nicobar Island (type-locality) and Rajendra Nagar, 35 km from Campbell Bay, Great Nicobar.

#### 41. *Glyptotermes sensarmai* Maiti

(Fig. 172)

##### 1. *Glyptotermes sensarmai* Maiti :

1974. Maiti, *Proc. zool. Soc.*, 27(2): 117-122. S, Pw. Holotype: S, in ZSI (Types examined). *Type-locality* : Khagribari, Antiamochar Beat, Coochbehar Forest Range, Koch Bihar District. West Bengal, India.

1983. Maiti, *Occ. Pap. Rec. zool. Surv. India*, No. 42 : 21, 38-40.

##### 2. *Glyptotermes nigrifrons* Mathur and Sen-sarma (wrong determination):

1975. Akhtar, *Bull. Dept. Zool. Univ. Panjab* (N.S.), Art. 7: 15, 17-19.

**IMAGO** : Unknown.

**SOLDIER** (Fig. 172) : Head-capsule brown, dark brown anteriorly and paler posteriorly; antennae yellow; labrum pale brown; mandibles blackish brown, dark brown posteriorly; pronotum slightly paler than posterior part of head; abdomen creamish white, tenth tergite brown, highly chitinized. Head and body sparsely hairy. Total body-length 5.0-7.0 mm. Head-capsule subrectangular, about one-and-a-half times as long as wide; length to base of mandibles 1.34-1.58, width 1.04-1.13; sides substraight or narrowing anteriorly a little; antero-lateral corners sharply projected; posterior margin round, antero-dorsal protuberances present, frons inclining at an angle of about 45° anteriorly and depressed medially; Y-suture faint. Eyes oval (0.10-0.13 mm long, 0.07-0.09 mm wide), whitish, situated at a

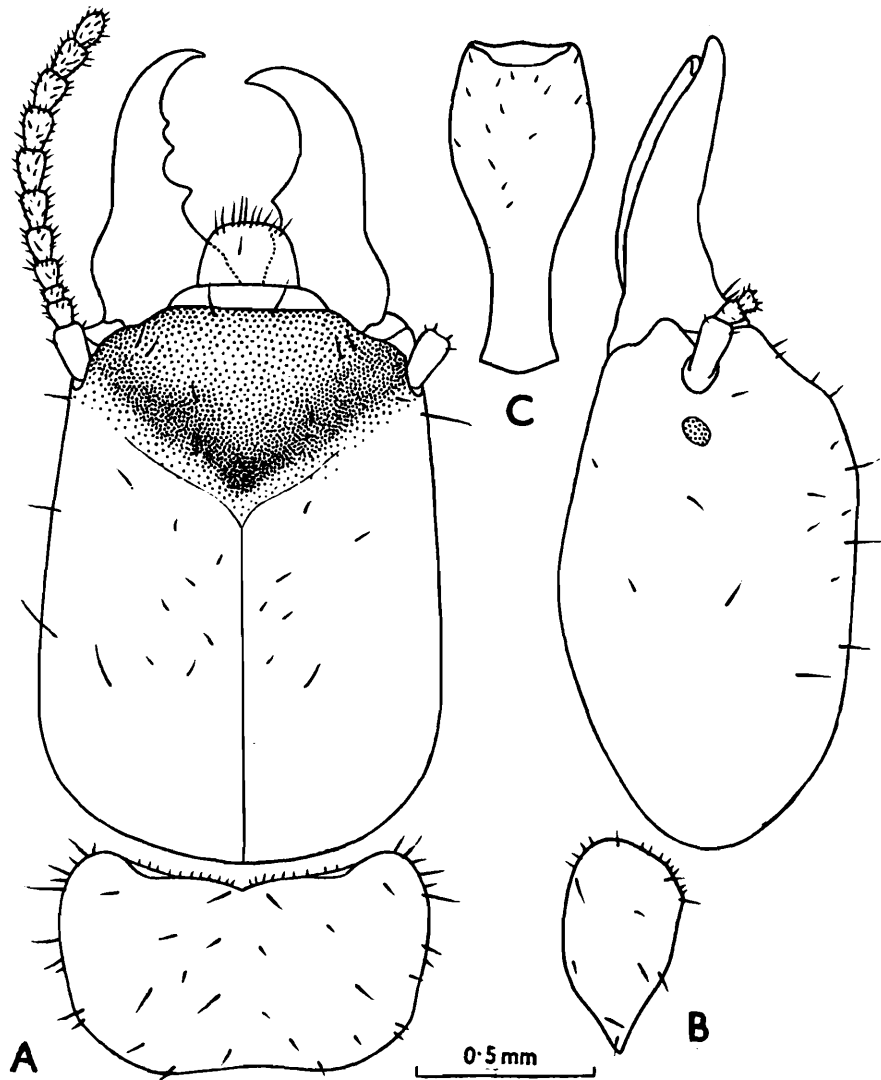

Fig. 172. *Glyptotermes sensarmai*. Soldier. (A) Head and pronotum, in dorsal view. (B) Same, in side view. (C) Postmentum.

distance of short diameter from antennae. Ocelli absent. Antennae with 11-12 segments; segment 1 long, cylindrical; 2 shorter than 1; 3 smallest and thin, 4 a little longer than 3. Clypeus subtrapezoidal; anteclypeus apilose, thin, hyaline, strip-like; postclypeus pilose, faintly demarcated from frons. Labrum subsquarish, rounded in front; hairy anteriorly and on body. Mandibles thick and short, about half of head-length (length 0.65-0.78); left with 3 marginals, 1st and 2nd small and closely situated, 3rd larger, separated from 2nd by a concavely rounded margin and situated medially; right with 2 fairly prominent marginals in basal half. Postmentum club-shaped; waist lying in posterior half, width at waist less than half to about half of maximum width; length 0.90-1.17, max. width 0.35-0.43, width at

waist 0.16-0.20 mm. Pronotum flat, subrectangular, only a little narrower than head-capsule; length 0.50-0.63, width 0.90-1.13 mm; anterior margin weakly incurved and with a faint median notch; sides rounded; posterior margin outcurved. Meso- and metanota shorter than pronotum, with weak emargination posteriorly. Legs short and pilose; apical tibial spurs 3:3:3; tarsi 4-jointed. Abdomen oblong and sparsely hairy; tenth tergite highly chitinised; cerci 2-jointed; styli single-jointed.

**PSEUDOWORKER** : Head and body creamish white and sparsely hairy. Total-length 5.0-6.0 mm. Head-capsule subcircular; length to base of mandibles 0.90-1.03, width 0.92-1.00 mm. Eyes small, oval and faintly marked. Antennae 10 to 11-segmented. Labrum broadly tongue-shaped. Mandibles typically *Glyptotermes*-type, each with an apical and two marginals. Pronotum flat, subrectangular, length 0.53-0.61, width 0.96-1.03 mm; about as wide as head or slightly wider; anterior margin fairly incurved medially. Legs and abdomen as in soldier.

**Distribution** : INDIA West Bengal.: Khagribari Forest (26° 20'N, 89°35' E), Koch Bihar District (type-locality).

#### 42. *Glyptotermes teknafensis* Akhtar

(Figs. 173, 174)

1. *Glyptotermes teknafensis* Chaudhry and Ahmad :

1972. Chaudhry and Ahmed, *Termites of Pakistan (Final Tech. Rep. PL 480 Proj.)*: vii, 4 (Nom. nud.)

2. *Glyptotermes teknafensis* Akhtar :

1975. Akhtar, *Bull. Dept. Zool. Univ. Panjab (N.S.)*, Art. 7: 15, 19-23, 190. Imago and Soldier. Holotype : Soldier, in Ahmad Coll., Dept. of Zoology, Panjab Univ., Lahore. *Type-locality* : Teknaf (Bangladesh).

3. *Glyptotermes chinpingensis* Tsai and Chen (Wrong determination) :

1983. Maiti, *Occ. Pap. Rec. zool. Surv. India*, No. 42 : 21, 35-36.

**IMAGO** (Fig. 173) : Head dark brown with smoky tinge; anteclypeus brownish yellow; labrum and antennae pale brown; pronotum dark brown; femora brown and tibiae and tarsi yellowish brown; wings light smoky brown; abdomen dark brown. Head sparsely hairy; labrum with a few bristles on margins and on body. Head round, sides subparallel; length to

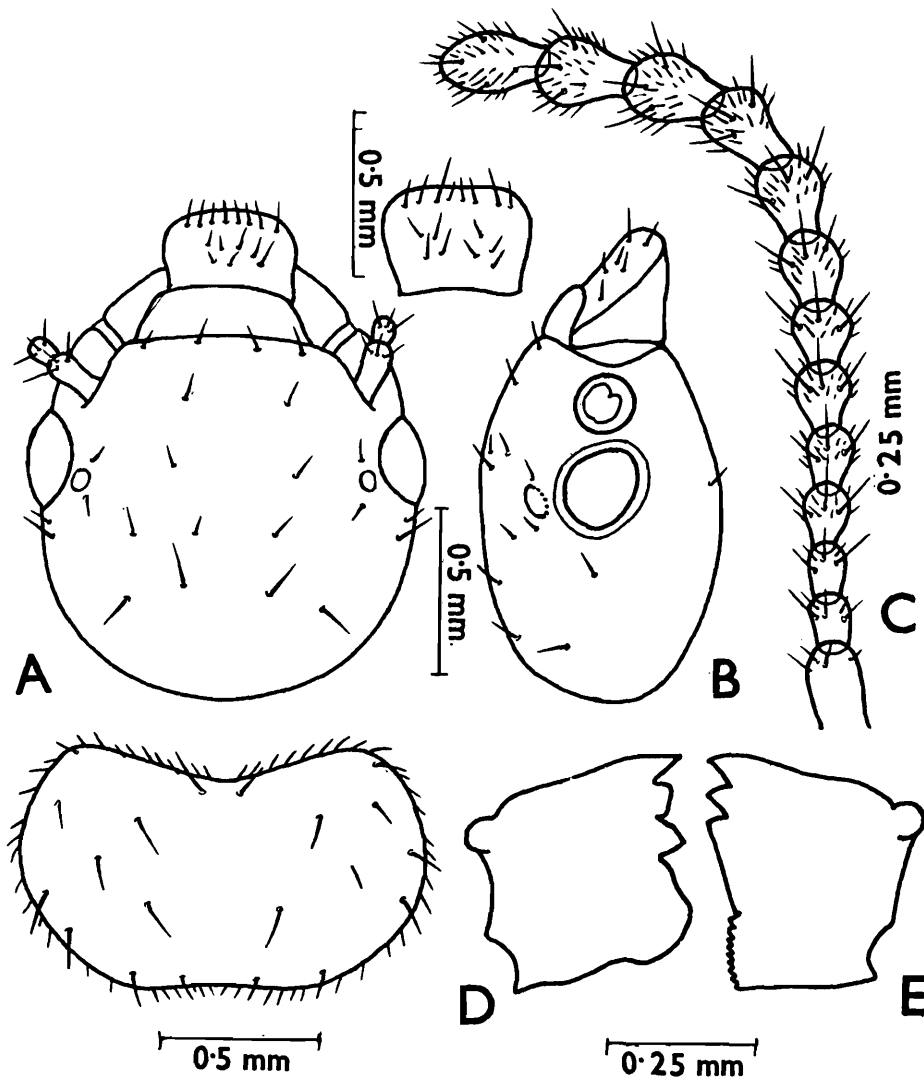

Fig. 173. *Glyptotermes teknaensis*. Imago. (A) Head and pronotum, in dorsal view. (B) Head, in side view. (C) Antenna. (D) and (E) Left and right mandibles. (After Akhtar, 1975).

base of mandibles 1.07-1.17, width 1.11-1.22 mm; Y-suture not visible. Eyes weakly bulging, ventral margin substraight; maximum diameter 0.28-0.31, minimum diameter 0.23-0.25 mm. Ocelli small, oval (0.07-0.10 mm long and 0.06-0.09 mm wide); not touching the eyes (eye-ocellus distance 0.02-0.03 mm). Antennae 13 to 15 segmented; second and third segments subequal. Labrum wider than long, sides slightly convex; anterior margin somewhat straight. Mandibles typically *Glyptotermes*-type. Pronotum subrectangular, length 0.64-0.71, width 1.10-1.32 mm; anterior margin

deeply incurved, antero-lateral corners broadly rounded; lateral sides convex; posterior margin slightly incurved. Tibial spurs 3:3:3. Wings as in genus.

**SOLDIER (Fig. 174) :** Head reddish brown, frons dark brown near base of mandibles; mandibles blackish, reddish black posteriorly; antennae and labrum brownish yellow; pronotum pale brownish; legs pale brown, paler than pronotum; abdomen pale brownish. Head and body sparsely hairy. Total body length 7.62-8.10 mm. Head-capsule subrectangular, much longer than broad, length (1.93-2.23 mm) about 1.6 times that of width (1.3-1.4 mm); sides substraight, posterior margin round; epicranial suture present; frons sloping in front at about 45° angle and depressed medially; frontal protuberances present at base of slope; antero-lateral corners of head rounded, not sharply pointed. Antennae 12-14 segmented; segments 3 and 4 shortest. Anteclypeus thin, hyaline, strip-like; postclypeus not clearly

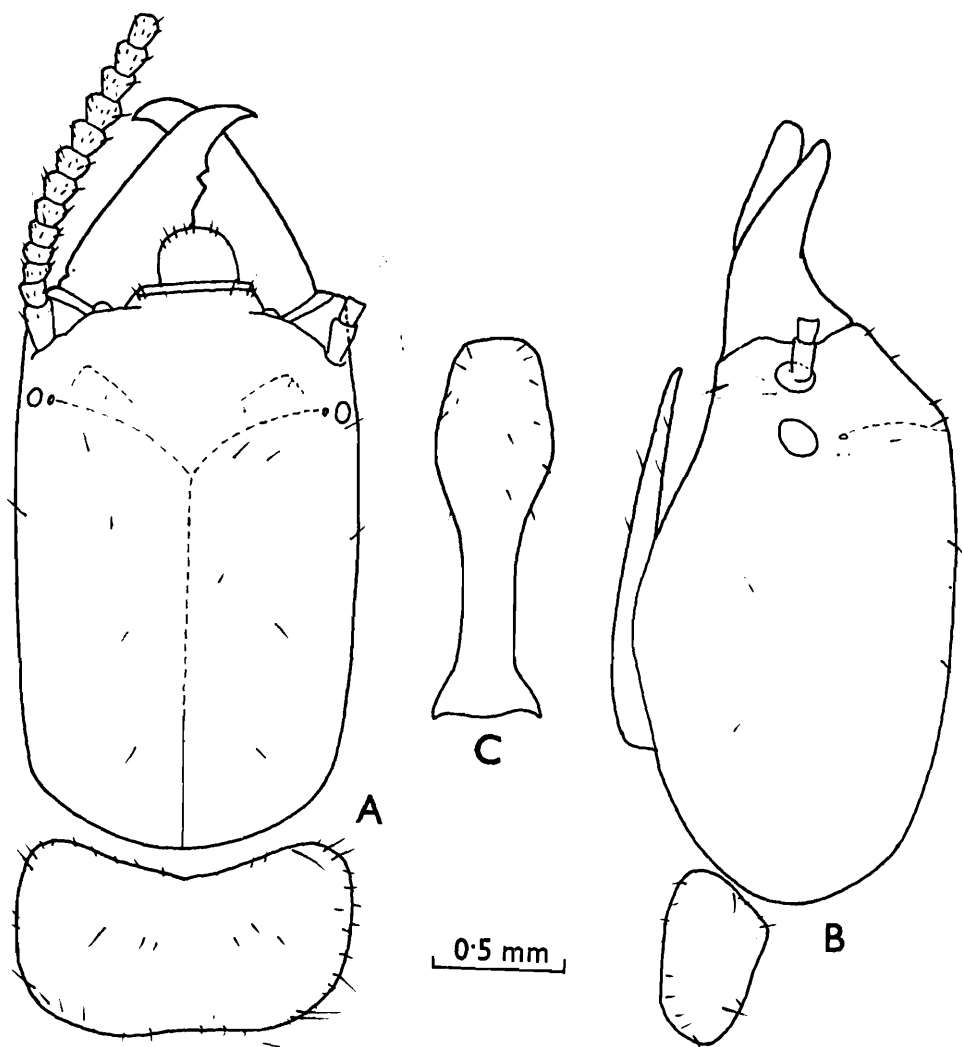

Fig. 174. *Glyptotermes teknaensis*. Soldier. (A) Head and pronotum, in dorsal view. (B) Same, in side view. (C) Postmentum.

demarcated from frons, dark brown in colour and hairy. Labrum subrectangular, broader than long; length 0.18, width 0.38 mm. Mandibles short (0.93-1.06 mm long), thick, less than half to about half of head without mandibles; left with three marginals, 1st and 2nd close to each other at distal third and 3 separated by a roundly incurved margin in middle; right with two marginals, first at about middle point and second below it. Postmentum long, club-shaped, with a long narrow waist; width at waist less than half of maximum width; length 1.27-1.53, max. width 0.50-0.53, width at waist 0.20-0.26 mm. Pronotum flat, rectangular, narrower than head (length 0.56-0.75, width 1.19-1.44 mm); anterior margin fairly deeply incurved; sides weakly convex; posterior margin substraight, with a weak incurving at middle. Meso- and metanotum almost as wide as pronotum. Legs short and stout, apical tibial spurs 3:3:3; tarsi 4-jointed. Abdomen oblong, tenth tergite not sclerotised.

**PSEUDOWORKER** : Head-capsule and antennae pale brown; labrum little darker; pronotum a little paler than head; abdomen creamish. Head-capsule subcircular, almost as broad as its length to base of mandibles (length to base of mandibles 1.25, width 1.25-1.28 mm). Eyes and ocelli not discernible. Antennae short, 12 segmented; segments short and broad. Mandibles typically *Glyptotermes*-type. Pronotum flat, a little narrower than head; anterior margin fairly incurved. Legs and abdomen as in soldier.

**Distribution** : INDIA : West Bengal Gailikhola Forest (Darjeeling Dist.)  
BANGLADESH : Teknaf (type-locality) and Ukhia.

**Biology** : In Bangladesh, this species is reported from dead portions of *Eugenia* sp., making longitudinal galleries, interconnected with each other by small holes (Chaudhry and Ahmad, 1972). It is also reported from *Syzigium* sp. (Akhtar, 1975). From Gailikhola Forest, West Bengal it is collected from a nest around a fire-scar on the trunk of an unknown tree.

### 43. *Glyptotermes tikaderi* Chhotani and Bose (Fig. 175)

*Glyptotermes tikaderi* Chhotani and Bose :

1985. Chhotani and Bose, *Rec. zool. Surv. India*, 82(1-4): 53-56. Soldier and Pseudoworker. Holotype : Soldier, in ZSI (Types examined). *Type-locality* : Hornbill, Namdapha (Tirap Dist., Arunachal Pradesh, India).

IMAGO Not known.

**SOLDIER (Fig. 175) :** Head-capsule dark brown, somewhat paler posteriorly; antennae brownish; labrum dark brown; mandibles blackish; pronotum, mesonotum and metanotum brownish; abdominal tergites pale brown, sternites creamish. Head and body sparsely hairy. Total body-length 10.0-11.2 mm. Head-capsule subrectangular, much longer than wide (length 3.20-3.50, width 1.90-2.05 mm); length 1.7 to 1.84 times that of width; when viewed laterally upper margin straight; frons sharply inclining in front (angle of inclination c 70°) and with faint striations; a weak protuberance present on either side in middle at beginning of slope; Y-suture present. Eyes translucent, small, elongately oval; 0.23-0.28 mm long. Ocelli minute, dot-like, situated at end of lateral suture, one on either side. Antennae short, with 14-15 segments; segment 1 long, cylindrical and strongly sclerotised; 2 cylindrical, shorter than 1; 3 or 4 shortest; onwards segments gradually becoming larger and broadly pyriform in shape; last segment short, ovate. Labrum short, broader than long, length 0.28-0.35,

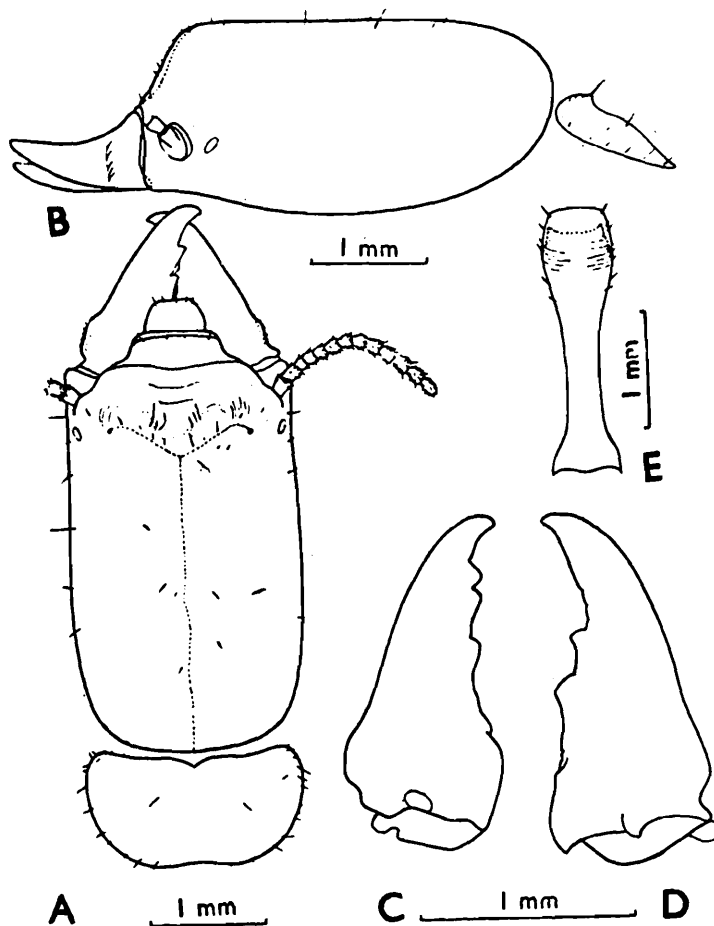

Fig. 175. *Glyptotermes tikaderi*. Soldier. (A) Head and pronotum, in dorsal view. (B) Same, in side view. (C) and (D) Left and right mandibles. (E) Postmentum. (After Chhotani and Bose, 1985b).

width 0.45-0.50 mm. Mandibles thick, short and stout; 1.48-1.58 mm long, less than half of head-length; apically weakly incurved; outer margin near base swollen and with a few short hairs. Left mandible with 4 marginal teeth; 1st and 2nd marginals close to each other, latter with a long posterior margin; 3rd with a long, curved posterior margin; 4th short. Right mandible with two marginal teeth in middle. Postmentum long, club-shaped; anterior broader portion with faint grooves and a few bristles, sometimes faintly bilobed; waist long and narrow, width at waist less than half to about half of maximum width; length 2.15-2.60, max. width 0.60-0.65 mm, width at waist 0.28-0.33 mm. Pronotum flat, much wider than long and almost as wide as head; length 1.05-1.08, width 1.93-2.03 mm; anterior margin deeply incurved; posterior margin faintly incurved. Meso- and metanota narrower than pronotum; latter only slightly wider than former. Legs short and stout; apical tibial spurs 3:3:3; tarsi 4-jointed. Abdomen elongate; cerci 2-jointed; styli single-jointed, finger-like.

**PSEUDOWORKER** : Head-creamish white; mandibles creamish with dark brown toothed margins; pro, meso- and metanota pale yellowish brown; abdomen creamish, paler than head. Head and body sparsely hairy. Total body - length c 7.0-9.5 mm. Head subcircular, slightly wider than its length to base of mandibles; length 1.35-1.53, width 1.50-1.58 mm. Antennae 14 to 15 segmented; segments 3-6 or 7 short, ring-like; 8 onwards broadly pyriform. Eye-spots translucent or faint grayish, round. Labrum broad, dome-like. Mandibles typically *Glyptotermes*-type. Pronotum semilunar; anterior margin deeply incurved; slightly narrower to slightly wider than head; length 0.88-0.95, width 1.40-1.60 mm. Legs and abdomen as in soldier.

**Distribution** : INDIA : Arunachal Pradesh: Hornbill, Namdapha (Tirap District), type-locality.

#### 44. *Glyptotermes tripurensis* Thakur

(Fig. 176)

*Glyptotermes tripurensis* Thakur :

1975. Sen-Sarma and Thakur, In Sen-Sarma, Thakur, Misra and Gupta, *Wood Destroying Termites of India (Final Tech. Rep. PL. 480 Proj. A7-FS-58)*: 11-52. (Included in key only, authorship assigned to Thakur).

1979. Thakur, In Sen-Sarma and Thakur, *Indian For. Rec. (N.S.) Ent.*, 13(1): 10-11, 60. S, Pw. Holotype : S, in FRI, Dehra Dun. *Type-locality* : Teliamura, Tripura, India.

1984. Thakur, *Bull. Ent.*, 25(2): 151-155. S, W.

IMAGO : Not known.

**SOLDIER (Fig. 176) :** Head-capsule yellowish brown, paler posteriorly, near base of mandibles dark brown; antennae yellowish; labrum pale brown; mandibles blackish; pronotum yellowish; abdomen creamish white, tenth tergite pale brownish, sclerotised. Head and body fairly pilose. Total body-length c 4.00-5.00 mm. Head-capsule subrectangular, longer than wide; width  $2/3$  to  $3/4$  of length; length 1.18-1.40, width 0.88-0.93 mm; sides substraight, posterior margin round; Y-suture present; frons sloping in front at an angle of nearly  $45^\circ$ , with a weak V-shaped depression. Eyes small, oval, whitish, situated at about long diameter from antennae. Ocelli minute, point-like, from eyes situated at a distance of about half the long diameter of eyes. Antennae 8 to 10 - segmented; segment 1 long, cylindrical; 2 about half of 1, shortest in 8-segmented antennae and almost as long as 3 in 9 or 10 segmented - ones; in the paratype examined, 3rd shortest; 4 to penultimate pyriform; last narrower, ovate and shorter than the preceding

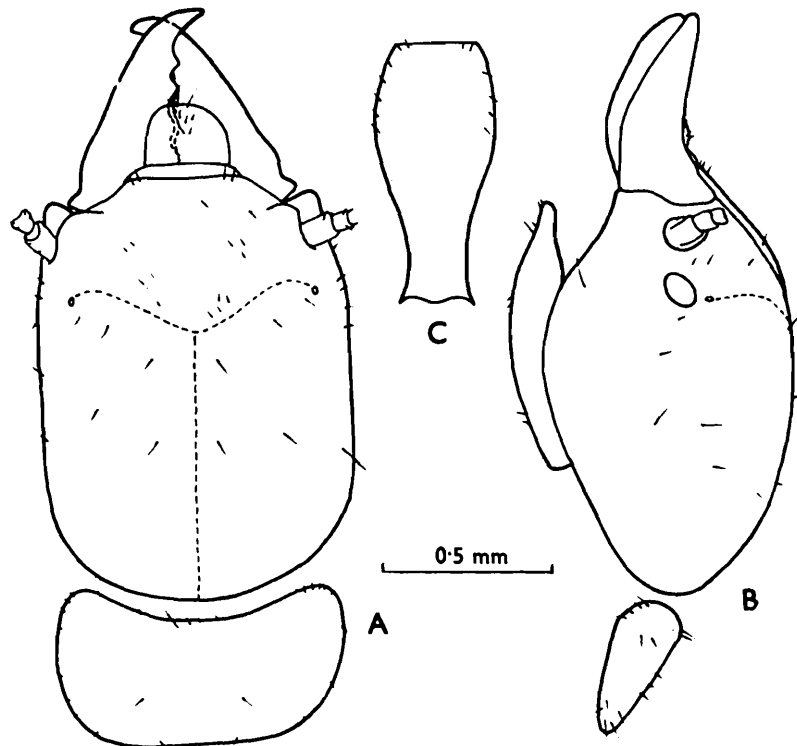

Fig. 176. *Glyptotermes tripurensis*. Soldier (Paratype). (A) Head and pronotum, in dorsal view. (B) Same, in side view. (C) Postmentum.

-ones. Mandibles short, stout; 0.58-0.70 mm long; about half of head-length; basally humped at outer margins; left with 3 marginals, 1st and 2nd marginals small, lying close to each other in distal half, 3rd marginal large, prominent, situated below middle, margin between 2nd and 3rd appreciably incurved; right with one or two large marginals in basal half. Postmentum short, club-shaped; waist narrow, width at waist about half of maximum width and lying near posterior end, length 0.70-0.93, maximum width 0.33-0.40, minimum width 0.15-0.20 mm). Pronotum flat, rectangular; anterior margin fairly deeply incurved and medially very faintly notched; posterior margin weakly outcurved and faintly invaginated medially; sides narrowing posteriorly; width 0.75-0.85, length 0.38-0.49 mm. Mesonotum as wide as or slightly wider and metanotum somewhat wider, than pronotum; both with substraight posterior margins. Legs short and stout; tibial spurs 3:3:3; tarsi-4-segmented. Abdomen oblong; 10th tergite sclerotised and pale brownish; cerci 2-segmented; styli single-jointed.

**PSEUDOWORKER** : Head and body creamish white and sparsely hairy. Total body length 3.45-4.70 mm. Head-capsule subcircular, slightly wider than long; length to base of mandibles 0.70-0.85, width 0.80-0.90 mm. Eyes suboval, faintly marked. Antennae 9 to 11-segmented; segment 3 longer than 4; latter shortest. Clypeus subtrapezoidal. Mandibles typically *Glyptotermes*-type. Pronotum, flat; deeply incurved at anterior and straight at posterior, margins; length 0.35-0.48, width 0.70-0.80 mm. Legs and abdomen as in soldier.

*Distribution* : INDIA : Tripura : Teliamura (type-locality).

#### 45. *Glyptotermes ukhiaensis* Akhtar

(Figs. 177, 178)

1. *Glyptotermes ukhiaensis* Chaudhry and Ahmad :

1972. Chaudhry and Ahmad, *Termites of Pakistan (Final Tech. Rept. PL 480 Proj.)* : vii, 4 (Nom. nud.)

2. *Glyptotermes ukhiaensis* Akhtar :

1975. Akhtar, *Bull. Dept. Zool. Univ. Panjab (N.S.)*, Art. 7: 15, 23-27. Im and S. Holotype : S., in Dept. of Zoology, Panjab University, Lahore. *Type-locality*. Ukhia (Bangladesh).

3. *Glyptotermes caudomunitus* Kemner :

1983. Maiti, *Occ. Pap. Rec. zool. Surv. India*, No. 42: 16,21, 32-35 (Wrong determination).

**IMAGO (Fig. 177) :** Head-capsule reddish brown to blackish brown; anteclypeus hyaline, postclypeus pale brown; labrum and antennae brownish, not darker than head (darker than head vide Akhtar, 1975); pronotum paler than head; coxae and femora brown, tibiae and tarsi pale; wings pale brownish; abdomen above darker than pronotum. Head sparsely hairy; labrum with a few short hairs at tip and in middle; pronotum fairly hairy with short and long hairs on margins and body. Total body-length with wings 5.5-6.00, without wings 4.0-4.3 mm. Head-capsule as wide as long, sides subparallel; Y-suture not discernible; length to base of mandibles 0.75-0.86, width with eyes 0.78-0.86 mm. Eyes oval, slightly bulging; max. diameter 0.25-0.27 mm. Ocelli small, broadly oval, not or slightly touching the eyes; 0.07-0.08 mm long, 0.05-0.06 mm wide. Labrum broad, tongue-shaped, wider than long; anterior margin nearly straight. Mandibles typically *Glyptotermes*-type. Left mandible without distinct notch between first and

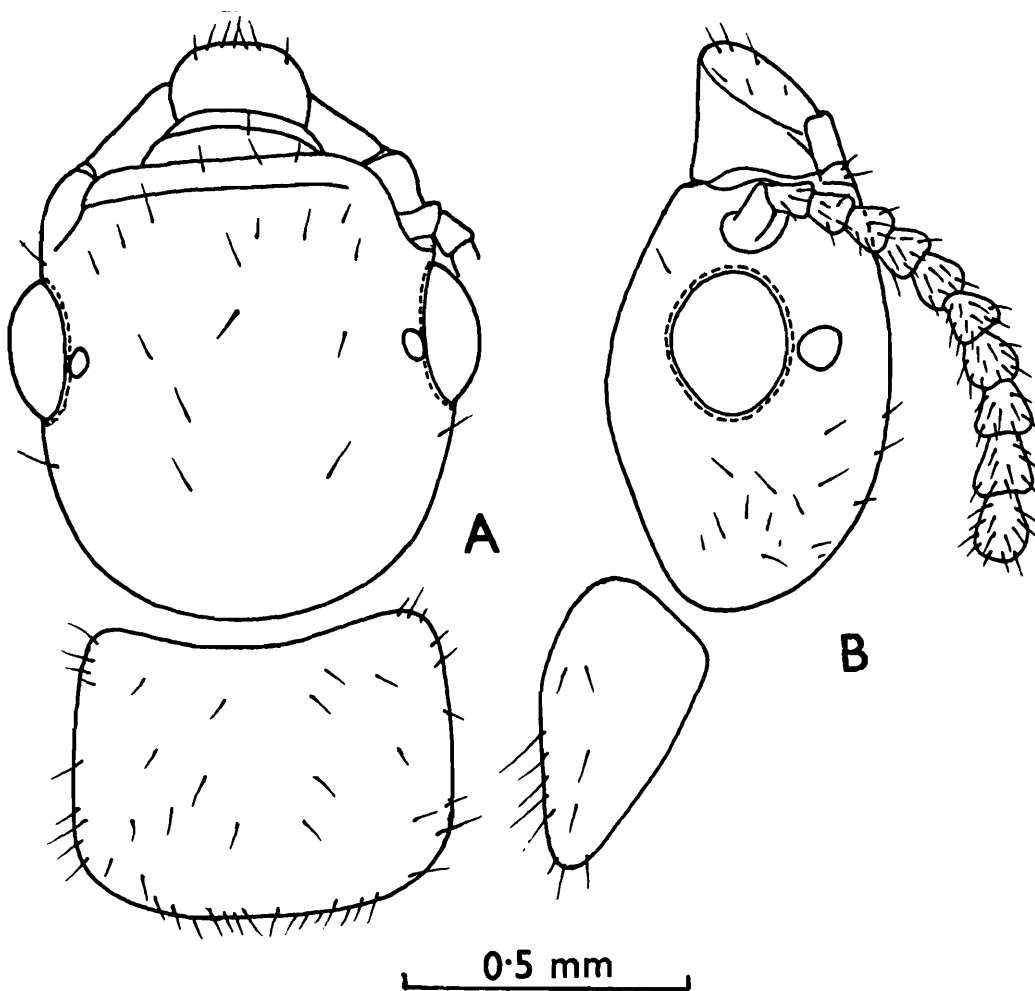

Fig. 177. *Glyptotermes ukhiaensis*. Imago. (A) Head and pronotum, in dorsal view. (B) Same in side view.

second marginals, antennae with 11-12 segments; 3rd segment very slightly shorter than 2nd (11-segmented antenna), short ring-like (12-segmented antenna); remaining segments gradually becoming longer. Pronotum a little narrower than head, anterior margin weakly incurved; antero-lateral corners sharp; lateral sides substraight or convex. Posterior margin convex, not emarginate; length 0.45-0.50, width 0.65-0.73 mm. Legs short and stout; tibial spurs 3:3:3. Abdomen oblong; cerci 2-jointed; styli in male finger-like, single-jointed.

**SOLDIER (Fig. 178) :** Head-capsule brownish, darker in region near postclypeus and frons; anteclypeus brownish yellow; labrum yellowish brown; mandibles reddish black; antennae brownish yellow; pronotum brownish; legs brownish yellow; abdomen yellowish brown, tenth abdominal tergite sclerotised, reddish brown. Head sparsely hairy; labrum with long bristles near anterior margin and a few in middle; thorax and abdomen fairly hairy. Total body-length 4.25-5.20 mm. Head-capsule subrectangular, sides subparallel; length 1.3-1.45 mm, about 1.44 times that of width (0.90-0.99 mm); antero-dorsal protuberances indistinct; frons sloping anteriorly at an angle of approximately  $45^\circ$ . Eyes present, not distinctly marked. Ocelli not discernible. Antennae with 10-11 segments; segment 2 longer than 3 or 4; 3 shorter than 4. Labrum as long as wide (length 0.18, width 0.23 mm); anterior margin slightly rounded. Mandibles short (0.50-0.57 mm long), basal humps weakly developed; length less than half of head-length (index 0.39-0.42); left mandible with three marginal teeth, first and second close to each other, 3rd almost at middle; margin between second and third incurved, without notch; right mandible with two medially placed marginal teeth. Postmentum club-shaped, waist long and weakly narrowed (length 0.89-0.93, max. width 0.40-0.41, width at waist 0.21-0.23 mm). Pronotum subrectangular, flat, slightly narrower than head; anterior margin weakly incurved; antero-lateral corners narrowly rounded; posterior margin nearly straight, with or without faint incurving in middle; length 0.44-0.48, width 0.66-0.78 mm. Legs short, stout; tibial spurs 3:3:3. Abdomen oblong, tenth abdominal tergite more strongly sclerotised.

**PSEUDOWORKER :** Head-capsule pale creamish yellow to pale brownish yellow; antennae, body and legs paler and labrum slightly darker. Head and body sparsely hairy. Total body length c 4.0-5.0 mm. Head-capsule subcircular; length to base of mandibles (0.75-0.88 mm) equal to width

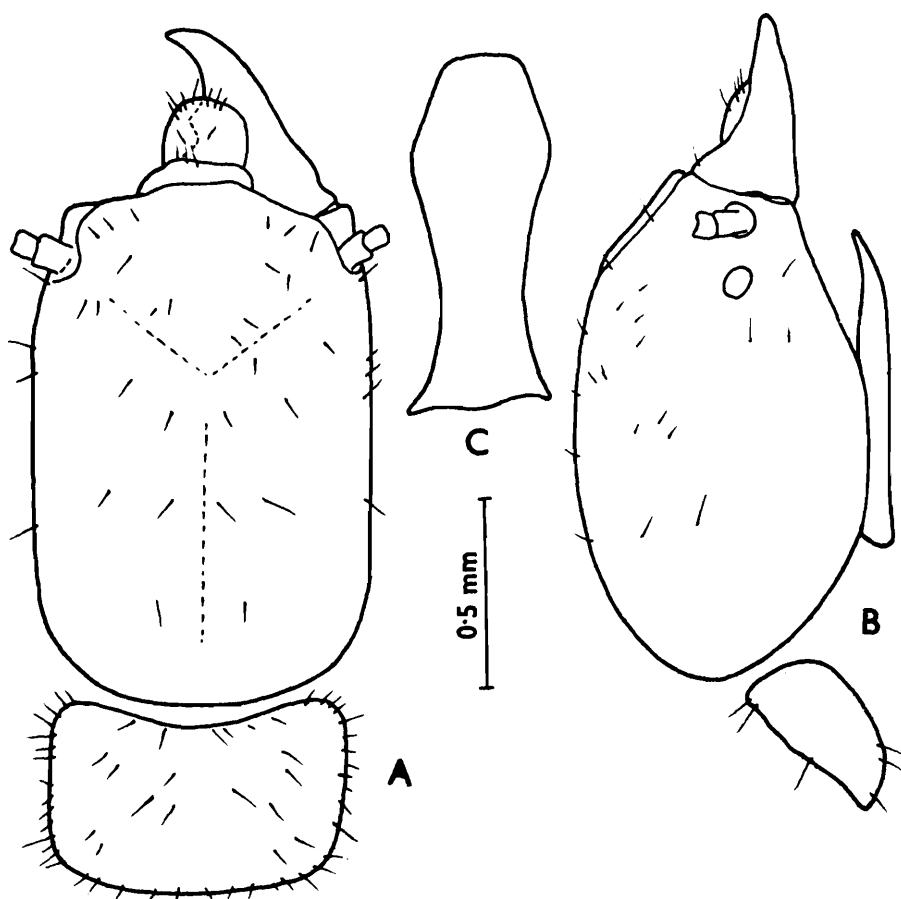

Fig. 178. *Glyptotermes ukhiaensis*. Soldier. (A) Head and pronotum, in dorsal view. (B) Same, in side view. (C) Postmentum.

(0.75-0.85 mm); sutures not discernible. Eyes very faintly marked 0.1-0.13 mm in diameter. Antennae short, with 10-11 segments; segment 3 short; 4 onwards gradually increasing in length and becoming broadly pyriform. Labrum broad, tongue-like; wider than long (length 0.18-0.20, width 0.38 mm); anterior margin substraight; with a few hairs at anterior margin and on body. Mandibles typically *Glyptotermes*-type; margin between 1st and 2nd marginals roundly incurving. Pronotum subrectangular, narrower than head (length 0.43-0.48, width 0.65-0.70 mm); anterior margin appreciably incurved. Legs as in soldier. Abdomen oblong.

**Distribution :** INDIA : Gailikhola Forest (Darjeeling Dist., West Bengal)  
Bangladesh Ukhia.

**Biology :** This species has been recorded making irregular galleries in *Syzigium* sp. trees in humid areas of Ukhia in Cox bazar Sub-division of Bangladesh and generally the main trunk was found to be attacked. It has also been reported from dead, fallen branch. The galleries are filled with

brownish excreta (Chaudhry and Ahmad, 1972). In Gailikhola Forest, West Bengal, its nest is reported to be formed of irregular, flattened tunnels inter communicated through small holes. Imagos have been collected from nest during April in Ukhia and November in Gailikhola Forest.

### Genus 7. *Calcaritermes* Snyder

*Calcaritermes* Snyder :

1925. Snyder, *J. Wash. Acad. Sci.*, 15(7) : 155.
1960. Roonwal and Sen-Sarma, *Contrib. Syst. Orient. Termites* (ICAR Ent. Monogr. 1) : 97, 98.
1961. Krishna, *Bull. Am. Mus. nat. Hist.*, 122(Art. 4) : 315, 316, 348, 349, 383, 384, 385, 386, 389. See for detailed synonymy, generic characters and species included.
1969. Emerson, *Am. Mus. Novit.*, No. 2359 : 3, 36-39, 53.
1970. Krishna, In *Biology of Termites* (Eds. Krishna and Weesner) Vol. 2: 132-133.
1970. Araujo, In *Biology of Termites*, (Eds. Krishna and Weesner) Vol. 2: 532.
1977. Araujo, *Cat. Isoptera Novo Mundo* : 10.
1981. Maiti and Chakraborty, *Bull. zool. Surv. India*, 4(1): 77, 78.
1986. Grassé, *Termitologia* vol. 3: 516.

Type of genus : *Calcaritermes imminens* Snyder.

#### 1. Characters of Genus *Calcaritermes*

*Imago* : Yellow brown to dark smoky brown in colour and sparsely hairy. Head subcircular, Y-suture present or absent. Eyes small, oval. Ocelli small, oval, generally touching eyes or faintly separated. Antennae 13 to 14-segmented. Mandibles each with an apical and two marginals. Left mandible with posterior margin of 1st marginal (1st + 2nd of some authors) equal to anterior margin of 2nd (3rd of some); margin between the two marginals generally concave, without notch in most species. Right mandible with posterior margin of 2nd marginal a little longer than molar plate. Pronotum a little narrower than or as wide as head with eyes; incurved at anterior margin. Wing membrane with pimpules (nodules of Emerson, 1969; in fossil termite *C. vetus* Emerson); venation as in *Glyptotermes*; costa, subcosta, radius, radial sector and media strongly chitinised and running close to anterior margin; cubitus weakly sclerotised and running medially. Subcosta in forewing short, meeting costa just outside scale (absent in hindwing); radius fusing with costa-subcosta a little further off; all veins

arising independently in forewing; in hindwing media arising from radial sector outside scale; faint cross veins between radial-sector and media and between media and cubitus present near distal end. Apical tibial spurs 3:3:3; tarsi 4-jointed; arolium present.

**Soldier** : Head dark, getting darker anteriorly; thick, squarish or subcylindrical; bilobed with V- or U- shaped depression in between lobes; frons sloping in front steeply at an angle of a little less than 90° to more than 90°, incurved in some species with dorsal rim overhanging; either only the ventral tubercle i.e. prolongation of ventral genae or two tubercles, a ventral-one as above and a dorsal-one above antennal socket (*C. krishnai*) may be present. Eyes oval, white, spot-like; either distinct or faint and indistinct. Ocelli absent or present as small, oval spots (*C. krishnai*). Antennae with 10-12 segments; segment 3 or 4 smallest, or subequal in size. Mandibles short, stout and with or without basal humps on outer margin; left mandible generally with 3 and right with 2 marginal teeth. Postmentum shape and size variable depending upon size and shape of head. Pronotum narrower to broader than head; anterior margin weakly to appreciably incurved; posterior margin either incurved appreciably or not incurved. Femora not swollen; tibial spurs 3:3:3; dorsal spur on fore-tibia thick, stout and larger than other two spurs; tarsi 4-jointed.

**Pseudoworker** : Pale, whitish to pale brownish white; fairly pilose. Head subcircular. Eyes unpigmented, oval. Antennae generally with 12 segments. Mandibles as in imago. Pronotum almost as wide as head. Apical tibial spurs 3:3:3; tarsi 4-jointed.

## 2. *Distribution and Composition of Calcaritermes* (Fig. 154)

Fifteen species (including one fossil species) of this genus are known. Of the living 14 species, 12 occur in the Neotropical, one in warm temperate Nearctic and one in tropical Oriental (Great Nicobar Island), regions. The fossil species is known from Chiapas, Mexico in the Neotropical region. There is some anomaly in the distribution of this genus since all the species except one in the oriental Great Nicobars are concentrated in Central America, warm temperate Florida and one as far South as Rio de Janeiro, Brazil. Maiti and Chakraborty (1981), while describing the species *krishnai* had placed it under *Glyptotermes* on the plea that the distribution of

*Calcaritermes* becomes anomalous as also thought by Krishna (in Maiti and Chakraborty, 1981). But the main character i.e. prominent outer foretibial spur in soldier, which separates *Calcaritermes* from *Glyptotermes* and found in the soldier of the Great Nicobar species, tends us to place the species in *Calcaritermes*. There are some other characters, such as the colour and size of tibial spurs in middle and hind legs and the tubercle on top of antennal socket which separate the only Indian species from the other *Calcaritermes*. But, we think that the size of tibial spurs does not warrant placing it in *Glyptotermes* and that the tubercles may be variable as found in the *Cryptotermes* species and may have evolved independently as in some Kalotermitid genera. It is perhaps a case of parallel evolution.

**46. *Calcaritermes krishnai* (Maiti and Chakraborty)**  
(Figs. 179-181)

*Glyptotermes krishnai* Maiti and Chakraborty :

1981. Maiti and Chakraborty, *Bull. zool. Surv. India*, 4(1): 71-78, figs. 1 and 2. Im, S, Pw. Holotype : S, in ZSI, Calcutta. Type-locality : Champa Bay, Great Nicobar Island, India.

1983. Maiti, *Occ. Pap. Rec. zool. Surv. India*, No. 42: 21, 37-38. Report from West Bengal not correct.

**IMAGO DEALATE (Fig. 179):** Head-capsule, pronotum, wing-scales and abdominal tergites dark brown; antennae, labrum, legs and sternites paler. Head and body sparsely pilose. Total length without wings 4.25 mm. Head-capsule subrounded, length to base of mandibles (0.88 mm) a little more than width including eyes (0.84 mm); posterior margin rounded. Eyes black, suboval, maximum diameter 0.25 mm; situated at a distance of 0.14 mm from lower margin of head-capsule. Ocelli oval, translucent, small; maximum diameter 0.07 mm; situated very close to ocular sclerite. Antennae 5+ segmented; segment 2 shortest. Anteclypeus whitish, subtrapezoidal; much broader than long. Postclypeus paler than frons, strip-like; anterior margin substraight. Labrum broadly tongue-shaped, pilose; anterior margin rounded; width much more than length (width 0.38, length 0.26 mm). Pronotum subrectangular, much broader than long (width 0.80, length 0.57 mm); about as broad as head without eyes; anterior margin deeply concave, without a median notch; posterior margin substraight; antero-lateral corners narrower than postero-lateral corners; with a few erect

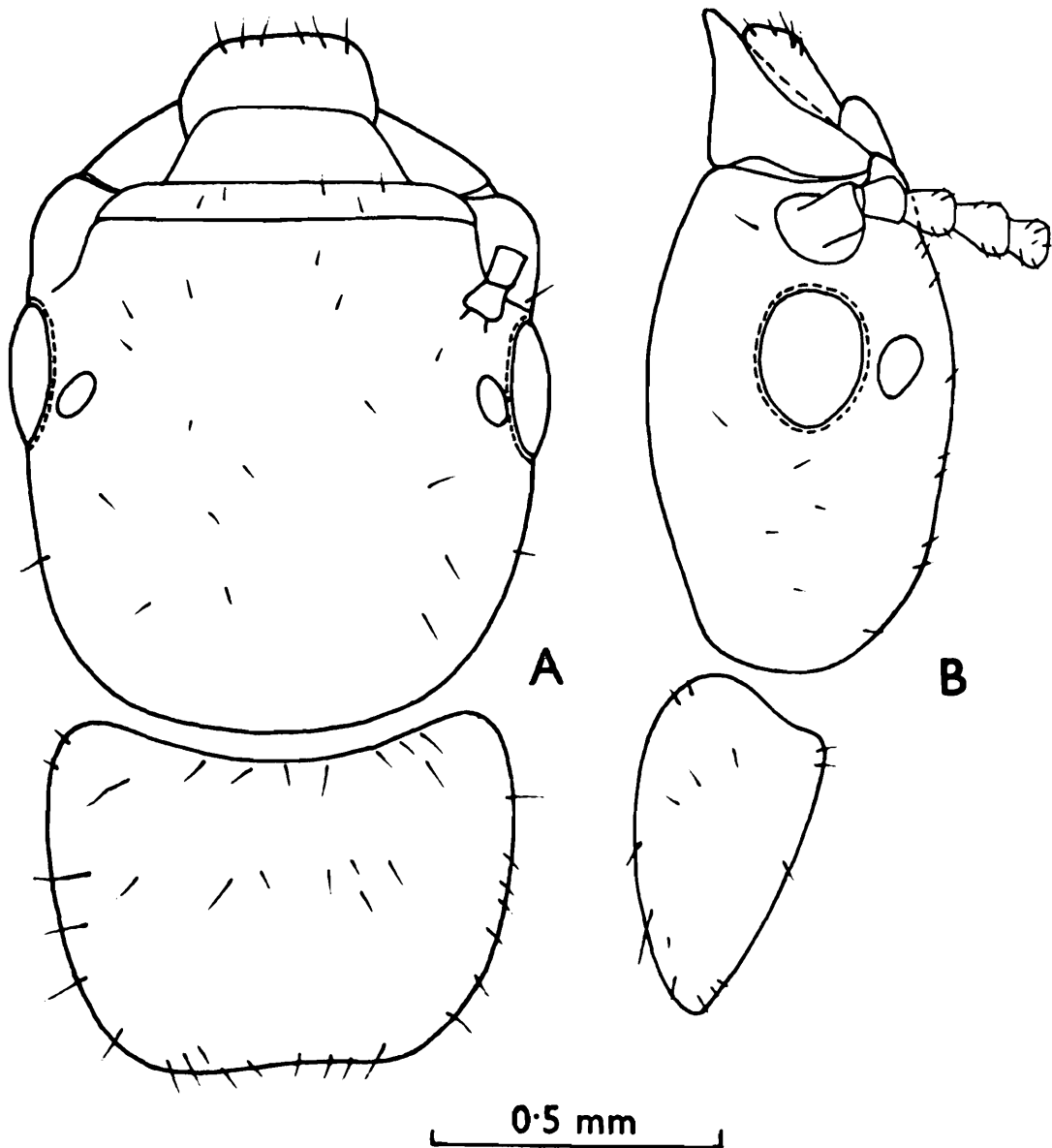

Fig. 179. *Calcaritermes krishnai*. Imago. (Paratype). (A) Head and pronotum, in dorsal view. (B) Same, in side view.

hairs on margins and on body. Legs short, pilose; apical tibial spurs 3:3:3; tarsi 4-segmented; arolium present. Forewing scale much longer than and covering hindwing scale. Abdomen oblong, pilose; cerci 2-segmented, styli one-segmented.

**SOLDIER** (Fig. 180, 181) : Head-capsule brown, anteriorly blackish; mandibles blackish brown; labrum dark brown; antennae pale brown; anteclypeus whitish, postclypeus black; pronotum brown; legs and abdomen yellowish brown, foreleg a little darker. Head and thorax moderately and abdomen fairly pilose; each tergum with a row of hairs on posterior margin.

Total length 5.4-6.0 mm. Head-capsule subsquarish, a little longer than broad; length to base of mandibles 1.15-1.123, width 1.15-1.20 mm; sides subparallel, sharply narrowed in region of antennal carinae; anterior part of head bilobed with a deep V-shaped depression in between lobes; surface of lobes very rough; frons sharply truncated in front; a prominent tubercle above each antennal socket and a ventral, horn-like projection of genae below antennal socket, present on either side; head dorsum, weakly depressed medially; Y-suture absent. Eyes suboval, whitish, dot-like; situated a little below antennal socket; eye-antennal distance 0.15-0.17 mm. Ocelli absent. Antennae 11-12 segmented, fairly pilose; segments 3 and 4 subequal, shortest. Anteclypeus whitish, narrow, much broader than long, weakly-narrowing in front to slightly convex margin. Postclypeus strongly chitinized, broader than long, anterior margin substraight; posterior margin not clearly differentiated from frons; at sides a little raised forming a shallow medial depression. Labrum weakly longer than broad, reaching

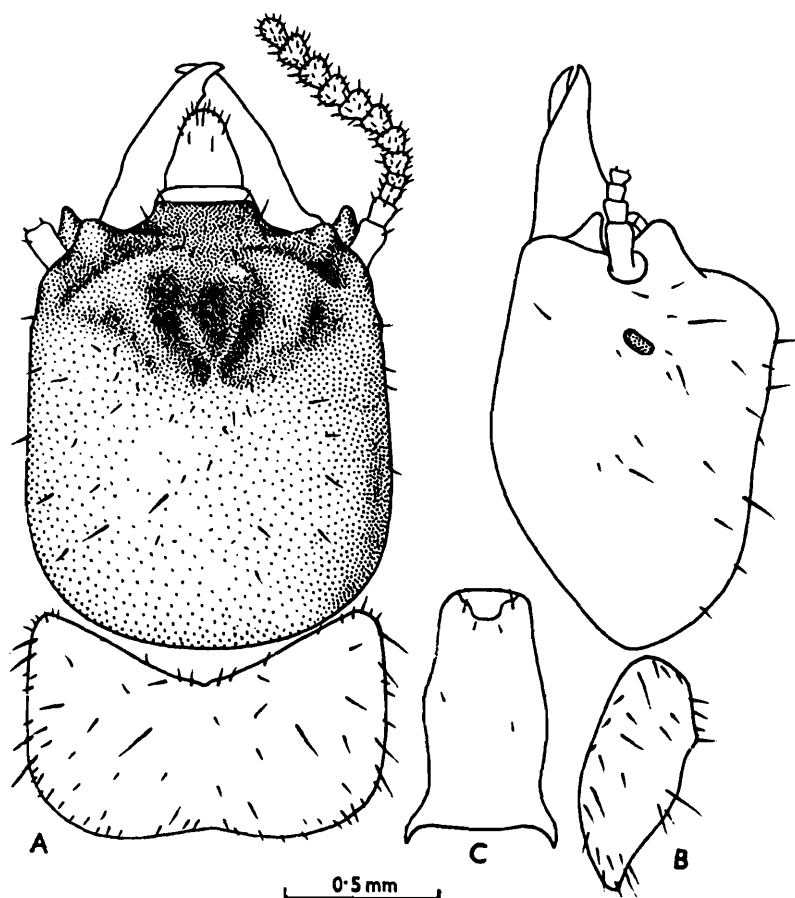

Fig. 180. *Calcaritermes krishnai*. Soldier (Holotype). (A) Head and pronotum, in dorsal view. (B) Same, in side view. (C) Postmentum.

beyond half of mandibles; length 0.25-0.27, width 0.23-0.26 mm; anterior margin subrounded, sides weakly convex; sparsely pilose. Mandibles a little longer than half of head to base of mandibles, short and with weak basal hump on outer margin. Left mandible with 3 marginal teeth; right with 2 stout marginal teeth. Postmentum longer than broad; maximum width at anterior one-third; length 0.65-0.75, width 0.38-0.45, minimum width 0.25-0.28 mm; sides narrowing both anteriorly and posteriorly; anterior margin concave; posterior margin weakly convex. Pronotum much broader than long (width 1.13-1.22, length 0.67-0.75 mm); almost as broad as head; anterior margin broadly and deeply concave; posterior margin deeply emarginate; a few hairs present on margins and on body. Legs short, stout, sparsely pilose; foreleg stouter than others; apical tibial spurs 3:3:3; foretibia with outer spur much thicker and stouter than the other two spurs; tarsi 4-segmented. Abdomen elongate; sparsely pilose; cerci 2-segmented; styli one - segmented.

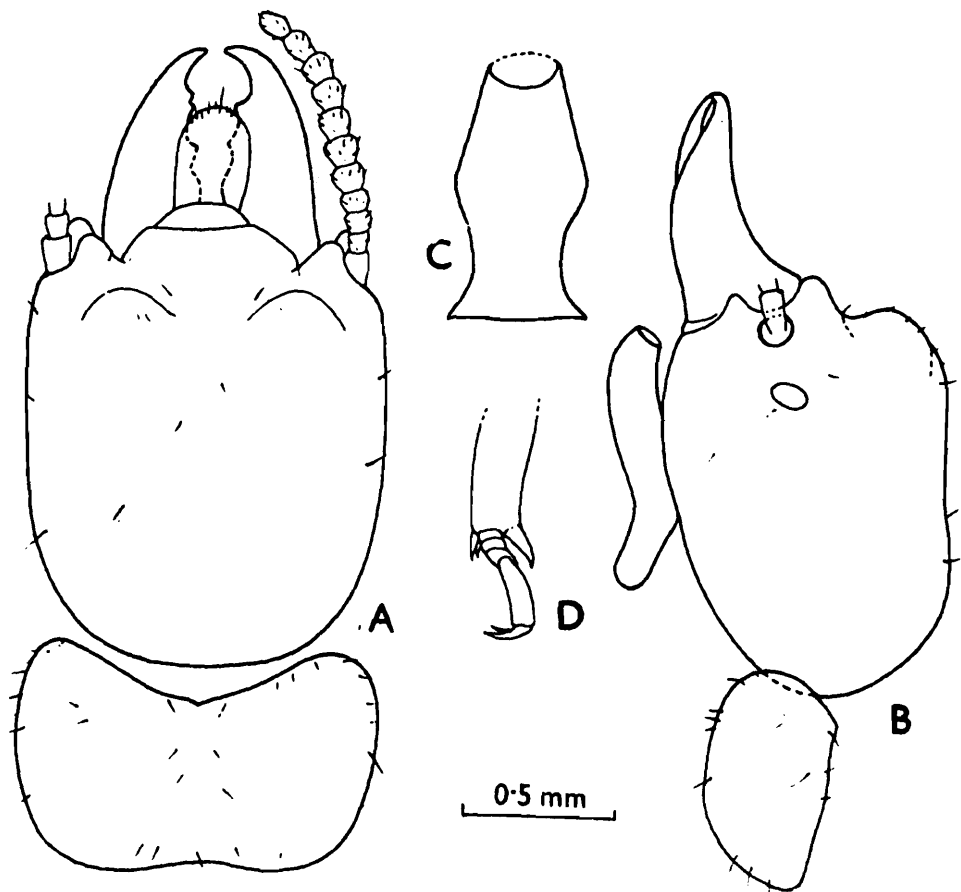

Fig. 181. *Calcaritermes krishnai*. Soldier (Paratype). (A) Head and pronotum, in dorsal view. (B) Same, in side view. (C) Postmentum. (D) Distal part of foreleg, showing the thick outer spur.

**PSEUDOWORKER** : Head-capsule and antennae white; rest of body brownish white. Head-capsule subcircular; length to base of mandibles 0.92-1.00; width 1.00-1.11 mm. Eyes suboval, large, whitish. Ocelli absent. Antennae 12-segmented, sparsely pilose; segment 4 shortest. Labrum broadly tongue-shaped; width 0.29-0.37, length 0.15-0.24 mm; anterior margin substraight; with a few hairs on margin and on body. Mandibles as in genus. Pronotum broader than long (width 0.90-1.03, length 0.60-0.69 mm); slightly narrower than head; anterior margin broadly concave; posteriorly weakly emarginate. Legs short, pilose; tibial spur formula 3:3:3; tarsi 4-segmented. Abdomen elongate pilose; cerci 2-segmented; styli one-segmented.

*Distribution* : INDIA : Great Nicobar Island : Champa Bay (type-locality). Record of the species from West Bengal (Maiti 1983), is due to mistake in identity of locality.

*Host* : Dead stump of "jungle Mewa"

*Remarks* : This species has been transferred here from *Glyptotermes* to *Calcaritermes*, for discussion see under composition and distribution of the genus.

### Genus 8. *Incisitermes* Krishna

*Incisitermes* Krishna :

1961. Krishna, *Bull. Am. Mus., nat. Hist.*, 122(Art. 4) : 315, 316, 317, 353-358, 383, 384, 385, 387, 389. (Synonymy, characters and species included.)
1969. Emerson, *Am. Mus. Novit.*, No. 2359 : 43-46.
1970. Krishna, In *Biology of Termites* Vol. 1(Eds. Krishna and Weesner): 132, 133, 134.
1973. Roonwal and Verma, *Zool. Anz.*, 191(5 & 6) : 390.
1975. Chhotani, *Zool. Anz.*, 194(1 & 2) : 114, 117, 119, 121.
1979. Araujo and Fontes, *Rev. bras. Ent.*, 23(1): 31.
1986. Grasse', *Termitologia* Vol. 3: 510.

Type of genus : *Kalotermes schwarzi* Banks.

#### 1. *Characters of Genus Incisitermes*

*Imago* : Pale brown to dark brown but usually pale brown; moderately hairy. Head subcircular. Eyes suboval, 0.25-0.50 mm in diameter. Ocelli

oval, generally touching eyes (except in *I. minor*). Antennae with 13-20 segments. Mandibles each with 2 marginals; left mandible with anterior margin of 2nd (3rd of some authors) marginal slightly longer than posterior margin of 1st (1st and 2nd of some authors); right mandible with molar plate subequal to posterior margin of 2nd marginal tooth. Pronotum as wide as or wider than head with eyes. Wings transparent, clear, lacking pimples-like nodules (in fossil species, *Incisitermes krishnai* with tubercles). Costa, subcosta, radius and radial sector strongly sclerotised; media and cubitus weak; media midway between radial sector and cubitus, a few cross veins between radial sector and media present; cubitus with 10-11 main branches. In forewing all veins arising independently from scale; in hindwing media arising from radial sector outside scale. Tibial spurs 3:3:3; tarsi 4-jointed; arolium generally present, sometimes absent.

*Soldier* : Head long, subrectangular, dorso-ventrally flattened; frons sloping in front; Y-suture present or absent. Eyes oval, generally unpigmented, sometimes pigmented, blackish. Ocelli absent. Antennae with 10-17 segments; segment 3 longest, club-shaped, strongly sclerotised. Mandibles short, stout, thick and massive; with or without basal humps; left with 3-5 marginal teeth, variable in size; right with 2 well developed marginals in middle; inner margin sometimes with serration; Postmentum club-shaped. Pronotum as broad as or broader than head; anterior margin deeply roundly or angularly incurved; sides rounded. Femora usually swollen; tibial spurs 3:3:3; tarsi 4-jointed.

*Pseudoworker* : Head subcircular, almost as wide as length to base of mandibles. Eyes small, suboval, pigmented. Ocelli absent. Antennae 12-15 segmented. Mandibles as in imago. Pronotum slightly wider than head. Legs as in soldier.

## 2. *Distribution and Composition of Incisitermes* (Fig. 154)

Twentyseven species (including one fossil species) are known in the genus. The living species are distributed in the Oriental (3 species), Papuan (5 spp.), Australian (one sp.), Nearctic (6 spp.) and Neotropical (15 spp.) zoogeographical regions. A few species are, however, common between papuan and Neotropical regions. From the Indian region only one species viz. *Incisitermes didwanaensis* Roonwal and Verma is reported so far.

47. *Incisitermes didwanaensis* Roonwal and Verma  
(Figs. 182, 183)

*Incisitermes didwanaensis* Roonwal and Verma :

1973. Roonwal and Verma, *Zool. Anz.*, **191**(5/6): 390-397. Im, S, Pw. Holotype: S, in ZSI, Calcutta. Type-locality : Didwana, Nagaur District, Rajasthan, India.

1976. Roonwal, *Zool. Jb. (Syst.)*, **103**: 464, 465, 467, 468, 480-481.

1977. Roonwal and Verma, *Rec. zool. Surv. India*, **72**: 425, 427, 432-433, 474.

1979. Roonwal, *Termite Life and Termite Control in Tropical South Asia* : 116.

IMAGO (DEALATE ♀) (Fig. 182) : Head light brown, thorax and abdomen paler; antennae dirty brownish white; postclypeus brownish; eyes black; labrum whitish; mandibles dark brown, margins blackish; legs dirty white, tibiae pale brownish. Head and body moderately pilose with short and long hairs. Total length c 8.9 mm. Head-capsule subrounded (length to mandibles base 1.47, width with eyes 1.47 mm); frons weakly sloping anteriorly. Anteclypeus slightly swollen, trapezoidal, translucent;

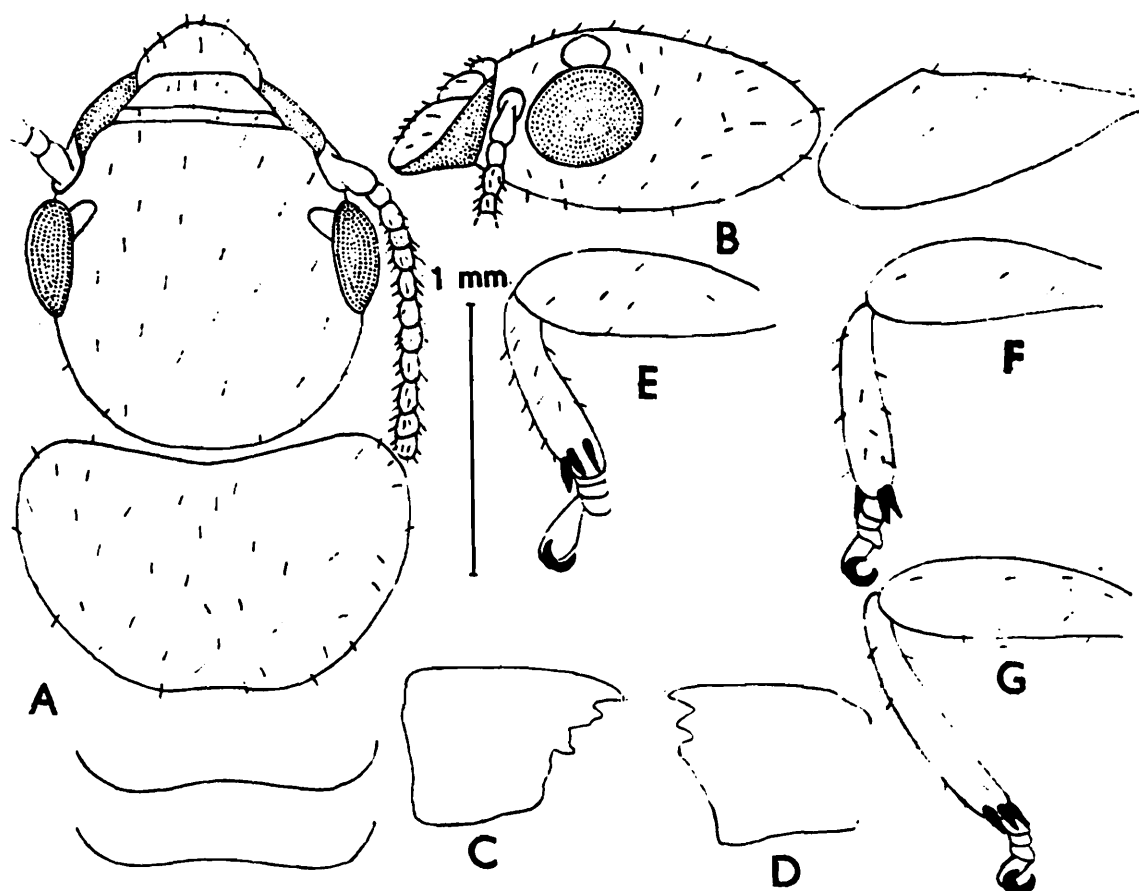

Fig. 182. *Incisitermes didwanaensis*. Imago. (A) Head and thorax, in dorsal view. (B) Same, in side view. (C) and (D) Left and right mandibles. (E) to (G) Fore-, middle - and hindlegs. (After Roonwal and Verma, 1973).

postclypeus broader than long. Eyes large, suboval, maximum diameter 0.45 mm. Ocelli oval, white spots, touching eyes. Antennae with 11-12 segments; segmen. 4 shortest. Labrum large, translucent, dome-shaped with a few small hairs all over. Mandibles as in genus. Pronotum large, subtrapezoidal, sides subrounded; broader than head with eyes (width 1.74, maximum length 0.95); anterior margin concave, posterior margin faintly convex, both without median notch. Meso- and metanota narrower than pronotum; posterior margin concave, without median notch. Hind femora short, swollen; hind tibiae slender, long; apical tibial spurs 3:3:3; tarsi 4-segmented; arolium absent. Abdomen weakly pilose; cerci short, 0.18 mm long, 2-jointed; styli short, single jointed.

**SOLDIER** (Fig. 183) : Head-capsule dark brown anteriorly, paler posteriorly; mandibles basally dark brown, anteriorly blackish; antennae proximally brownish, distally paler; pronotum pale straw-coloured, meso- and metanota paler; abdomen and legs whitish. Head and body moderately pilose with small hairs all over. Total length with mandibles 9.7-10.3 mm. Head-capsule subrectangular (length to mandible-base 2.10-2.37, width 1.84-2.00 mm); anteriorly weakly convergent; posterior margin weakly concave; frons gently sloping in front; Y-suture not visible. Eyes present as small, suboval, blackish spots, flush with head-surface; maximum diameter

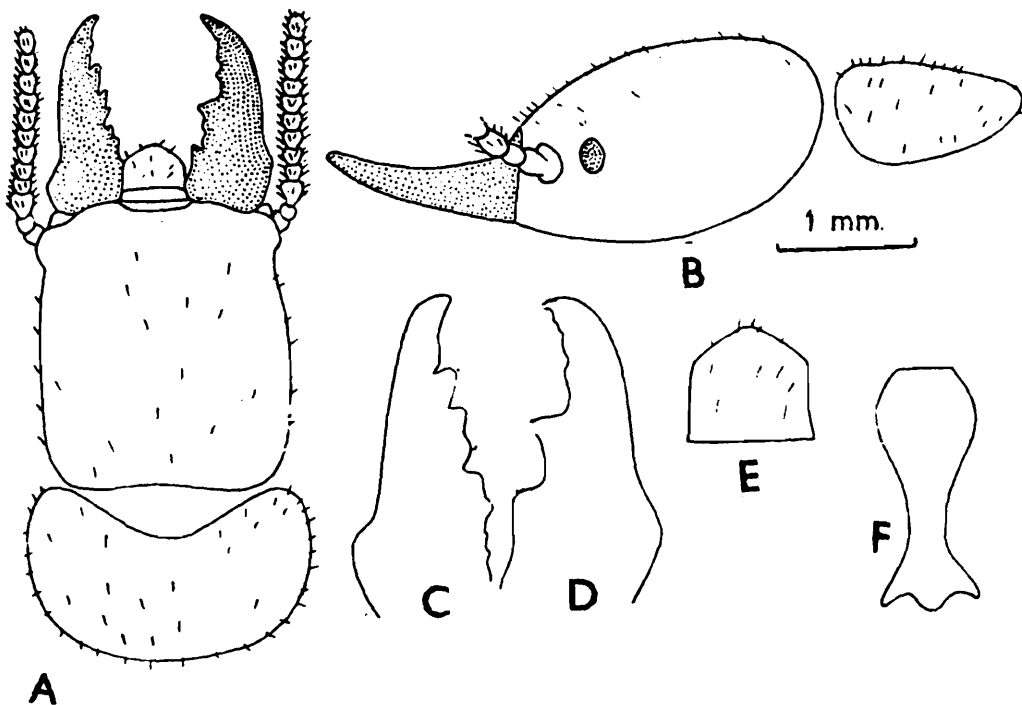

Fig. 183. *Incisitermes didwanaensis* Soldier. (A) Head and pronotum, in dorsal view. (B) Same, in side view. (C) and (D) Lef. and right mandibles. (E) Labrum. (F) Postmentum (After Roonwal and Verma, 1973).

0.26 mm. Ocelli absent. Antennae 12 to 15 (mostly 13)-segmented; segment 2 shortest. Anteclypeus narrow, translucent; postclypeus also narrow, dark brownish. Labrum translucent, whitish, sparsely pilose; with a weak, medial tip. Mandibles thick and stout; distally weakly incurved and with a basal hump on outer margin; length of mandibles 1.63 mm. Left mandible with 5 marginal teeth; Right with 2 marginals behind middle point. Postmentum long (median length 1.74 mm), club-shaped or inverted vase-shaped; broadest anteriorly and curving behind into a narrow waist (maximum width 0.74-0.79, minimum width 0.37 mm) in posterior one-fourth; anterior margin straight; posterior margin wavy (concave and projected out medially). Pronotum subrectangular, slightly broader than head (maximum width 2.05-2.21 mm); anterior margin deeply concave, posterior margin weakly convex, both without median notch. Meso- and metanota narrower than pronotum. Legs short, hind femur greatly swollen; fore and hind femora less so swollen; tibiae short, apical tibial spurs 3:3:3; tarsi 4-segmented. Abdomen sparsely pilose; cerci 2-segmented, 0.18 mm long; styli one-jointed, 0.09 mm long.

**PSEUDOWORKER** : Head and mandibles dirty white; mandible margins blackish; rest of body dirty translucent white. Body moderately pilose. Total length 6.6-8.9 mm. Head capsule subrounded; length to base of mandibles 1.32-1.58, width 1.37-1.58 mm. Eyes small, suboval, blackish spots; flush with head. Anteclypeus narrow, trapezoidal, with weakly concave anterior margin; postclypeus broader. Labrum dome-shaped, as in Imago; with a few hairs. Antennae whitish, 12 to 15 (mostly 15)-segmented; segments 3 and 4 subequal, shortest. Mandibles as in genus. Pronotum broader than head (width 1.42-1.84, length 0.63-1.05 mm); anterior and posterior margins weakly concave, both without median notch. Legs as in soldier. Abdomen longish, pilose; cerci 2-jointed, short; styli single-jointed, minute.

*Distribution* : INDIA : Rajasthan : Didwana (Nagaur Dist.), type-locality.

### Genus 9. **Bifiditermes** Krishna

*Bifiditermes* Krishna :

1961. Krishna, *Bull. Am. Mus. nat. Hist.*, 122 (Art. 4): 315, 316, 317, 365-370, 384, 385, 387-388, 389. (Synonymy, characters, species included.)

1965. Bouillon and Mathot, *Zooleo*, No. 1 : 12, 18, 38-39.

1966. Bouillon and Mathot, *Zooleo*, No. 1 (Suppl. 1) : Table Measurements.
1971. Bouillon and Mathot, *Zooleo*, No. 1 (Suppl. 2) : Table Measurements, 7.
1972. Chaudhry and Ahmad, *Termites of Pakistan* (Final Tech. Rep. PL 480 Programme): 5.
1972. Coaton and Sheasby, *Cimbebasia Mem.*, No. 2 : 21, 22, 24, 46, 48, 101, 102.
1973. Chhotani and Bose, *Zool. Anz.*, 190(3/4): 232, 234.
1974. Akhtar, *Pakistan J. Zool.*, 6(1 & 2) : 88, 89, 96, 98-99, 100, 101.
1975. Sen-Sarma et al., *Wood Destroying Termites of India* (Final Tech Rept. PL 480 Progr.) : 7, 32.
1975. Chhotani, *Zool. Anz.*, 194(1/2): 114, 116, 117, 119, 121, 122.
1980. Chhotani, *Tech Monog. Zool. Surv. India*, No. 4 : 22.
1986. Roonwal, *Zool. Anz.*, 216(1/2) : 81, 82, 86.
1986. Roonwal, Verma and Bisen, *Proc. Indian natn. Sci. Acad.*, (B) 52(2): 242, 265.
1986. Grasse', *Termitologia* Vol. 3: 508.

Type of genus ; *Calotermes madagascariensis* Wasmann.

### 1. Characters of Genus *Bifiditermes*

*Imago* : Pale brown to dark brown in colour. Head-capsule subrectangular; with eyes almost as wide as length to base of mandibles; Y-suture present or absent. Eyes medium to fairly large in size, 0.37-0.70 mm; subcircular to broadly oval. Ocelli oval, generally touching eyes, sometimes slightly separated. Antennae 15-20 segmented. Mandibles each with an apical and two marginals. Left mandible with anterior margin of 2nd (3rd of some) longer than posterior margin of 1st (1st plus 2nd of some). Right mandible with molar plate shorter than posterior margin of 2nd marginal. Pronotum as wide as or slightly wider than head; anterior margin weakly incurved. Wing-membrane with or without tubercles; with papillae, pimpules and tubercles (in *beesoni*); costa, subcosta (absent in hindwing), radius and radial sector thick, sclerotised and near anterior border; media and cubitus weak, media running midway between radial sector and cubitus; subcosta in forewing short, meeting costa just outside scale; radius meeting costa from before middle to beyond middle of wing-membrane; radial sector with 3 to 7 branches; media arising from cubitus outside scale in forewing and from radial sector in hindwing; cross veins between media and radial sector present; cubitus with 10-14 branches to posterior margin. Legs short and slender; apical tibial spur 3:3:3; tarsi 4-jointed; arolium absent. Abdomen elongate and hairy.

*Soldier* : Head-capsule subrectangular, long and thick; sides straight, parallel, sometimes faintly converging in front; frons sloping in front at 45° angle, medially depressed and with lateral dorsal corners above antennae slightly prominent and elevated in some species. Eyes small, oval; either pigmented or unpigmented. Ocelli absent. Antennae 10-18 segmented; segment 3 long and clavate; carinae large, prominent, projecting out. Labrum variable in shape; anterior margin projecting in front medially or rounded. Mandibles large, stout, basally humped at outer margins and incurved apically. Left mandible with 4-5 (generally 5) marginal teeth, shape and size of teeth variable. Right mandible with 2 large, medially situated marginal teeth; margin between teeth substraight or angular. Postmentum long, club-shaped; anterior broader portion sometimes bilobed. Pronotum flat, subrectangular; as wide as or little wider than head; anterior margin broadly or deeply and angularly incurved, with or without median notch; posterior margin straight or weakly rounded, with or without a median notch. Legs short and slender; femora normal or slightly swollen; apical tibial spurs 3:3:3; tarsi 4-jointed. Abdomen elongate; cerci short, 2-jointed.

*Pseudoworker* : Head straw coloured; body creamish white. Moderately pilose. Head-capsule subcircular. Eyes rudimentary, black, subcircular, flush with head. Ocelli absent. Antennae 13 to 15-segmented. Labrum broadly tongue-shaped. Mandibles as in imago. Pronotum subrectangular; anterior margin concave; posterior margin convex. Legs and abdomen as in soldier.

## 2. Distribution and Composition of *Bifiditermes*

Of the 12 species of the genus known from the world 3 occur in Oriental, 2 in Australian, 6 in Ethiopian and one in Malagasy regions. The three Oriental species are reported from Thailand and Sulawesi (one species, *indicus*) and from India and Sri Lanka (2 species, *beesoni* and *pinto*). The two Indian region species, as follows, are keyed and described here.

1. *Bifiditermes beesoni* (Gardner). India, Pakistan.
2. *B. pinto* (Kemner). Sri Lanka, India.

## 3. Keys to Indian Region Species of *Bifiditermes*.

### IMAGOES

1(2) Larger: Head-width 1.36-1.51, pronotum-width 1.55-1.68. Forewing : Media arising from cubitus just at suture; subcosta long, runn-

ing upto 1/4th of wing and radius upto beyond middle and then fusing with costa.....

*beesoni*

- 2(1) Smaller : Head-width 1.16-1.20, pronotum width 1.27-1.45 mm. Forewing : Media arising from cubitus outside suture in wing membrane; subcosta short, running up to 1/6 of wing and radius stopping short of middle and then fusing with costa.....

*pintoi*

### SOLDIERS

- 1(2) Pronotum wider (1.70-2.29 mm wide); antero-lateral corners broadly rounded. Anterior broader portion of postmentum about 2/3 of total length and faintly or not bilobed .....

*beesoni*

- 2(1) Pronotum narrower (1.60-1.75 mm wide); antero-lateral corners narrowly rounded. Anterior broader portion of postmentum about 1/2 of total length and clearly bilobed.....

*pintoi*

### 48. *Bifiditermes beesoni* (Gardner) (Figs. 184-186)

#### 1. *Kalotermes beesoni* Gardner :

1945. Gardner, *Indian J. Ent.*, 6(1944): 103. S, Ny. Lectotype (selected Roonwal and Sen-Sarma, 1960) : S, in FRI, Dehra Dun, India. Type-locality : Haldwani, Uttar Pradesh, India.

1949. Snyder, *Smiths. misc. Coll.*, 112: 13.

1955. Khan and Ahmad, *Biologia*, Lahore, 1(1): 28-30.

1955. Ahmad, *Biologia*, Lahore, 1(2): 204-206.

1958. Ahmad, *Biologia*, Lahore, 4(1-2): 36-37.

1960. Roonwal and Sen-Sarma, *Contrib. Syst. Orient. Termites* (ICAR Ent. Monogr. 1) : 101, 102, 103-110. (Synonymy, description, etc.)

1962. Chhotani, *Proc. 1st All-India Congr. Zool.*, Part 2: 476-478, 1 pl. Biology.

1962. Chhotani, *Termites in Humid Tropics* (Proc. New Delhi, Symp. 1960) : 73-75.

#### 2. *Bifiditermes beesoni* (Gardner) :

1961. Krishna, *Bull. Am. Museum nat. Hist.*, 122 (Article 4) : 369.

1972. Chaudhry and Ahmad, *Termites of Pakistan (Final Tech. Report PL 480 Progr.)* : ix, 5, fig. 4.

1974. Akhtar, *Pakistan J. Zool.*, 6(1 & 2): 101.

1975. Chhotani, *Zool. Anz.*, 194(1/2) : 113, 114, 119.

1975. Sen-Sarma et al., *Wood Destroying Termites of India (Final Tech. Rept. PL 480 Progr.)* : 32, 34, 52.

1980. Chhotani, *Tech. Monogr. Zool. Surv. India*, No. 4: 3, 22-23.

1986. Roonwal, *Zool. Anz.*, 216(1/2) : 81, 82, 83.

1986. Roonwal, Verma and Bisen, *Proc. Indian natn. Sci. Acad.*, (B) 52(2) : 241, 242.

**IMAGO** (Figs. 184 A-C, 185) : Head capsule brown with reddish tinge; antennae basally brown, distally paler; labrum and pronotum much paler than head; wing-scales and anterior veins brownish; wing membranes transparent, whitish. Head and body sparsely pilose. Total length excluding wings 7.4-9.5 mm. Head-capsule subrounded; length to base of mandibles 1.18-1.56 mm, width with eyes 1.36-1.51 mm; frons gently sloping in front and with a slight, median depression; Y-suture prominent. Eyes large (maximum diameter 0.48-0.59 mm), subcircular, lying close to antennae. Ocelli small, suboval, maximum diameter 0.18-0.25 mm, whitish, translucent; obliquely and dorso-ventrally elongated; touching eyes. Antennae with 16-18 segments; segment 4 shortest. Anteclypeus fairly long, trapezoidal, whitish, apilose. Postclypeus subrectangular, darker than frons; 2 pairs of hairs present at anterior margin. Labrum subsquarish, broadest in anterior one third (length 0.35-0.55 mm); anterior margin subrounded; with long and short hairs anteriorly and on body. Mandibles as in genus. Pronotum broader than head with eyes; flat, subrectangular (width 1.55-1.60, length 1.0-1.10 mm); anterior margin concave; sides subrounded; posterior margin substraight. Legs short, slender; densely pilose; femora slender;

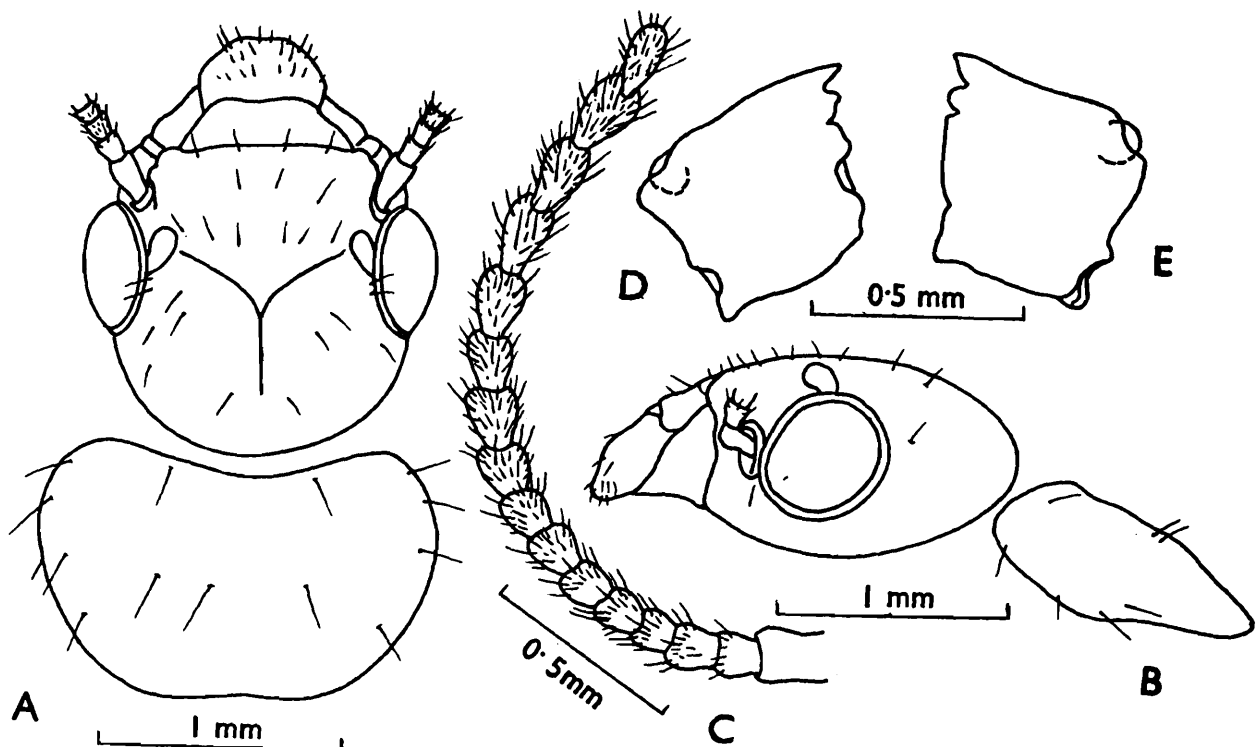

Fig. 184. *Bifiditermes beelsoni*. Imago (A-C), Pseudoworker (D-E). (A) Head and pronotum, in dorsal view. (B) Same, in side view. (C) Antenna. (D) and (E) Left and right mandibles. (Redrawn from Roonwal and Sen-Sarma, 1960).

apical tibial spurs 3:3:3; tarsi 4-segmented; arolium between claws absent. Wing-membrane with papillae, pimpules and tubercles; apilose. Forewing : 9.5-10.0 mm. Wing-scale longer than hindwing-scale. Costa, subcosta, radius and radial sector thick and strongly chitinised, running close to each other near anterior margin; media and cubitus weakly chitinised; subcosta long, meeting costa at about  $1/4$  of wing-membrane; radius running beyond middle and then meeting costa; radial sector with 5-6 branches to costa beyond confluence of radius and costa; media arising from cubitus just at scale-suture, with evanescent veins to radial sector and cubitus; cubitus with about 10 branches to posterior border. Hindwing 9.0-9.5 mm. Costa, radius sector and cubitus as in forewing; subcosta absent and media arising from radial-sector inside wing-membrane. Abdomen elongate; cerci short, 2-jointed.

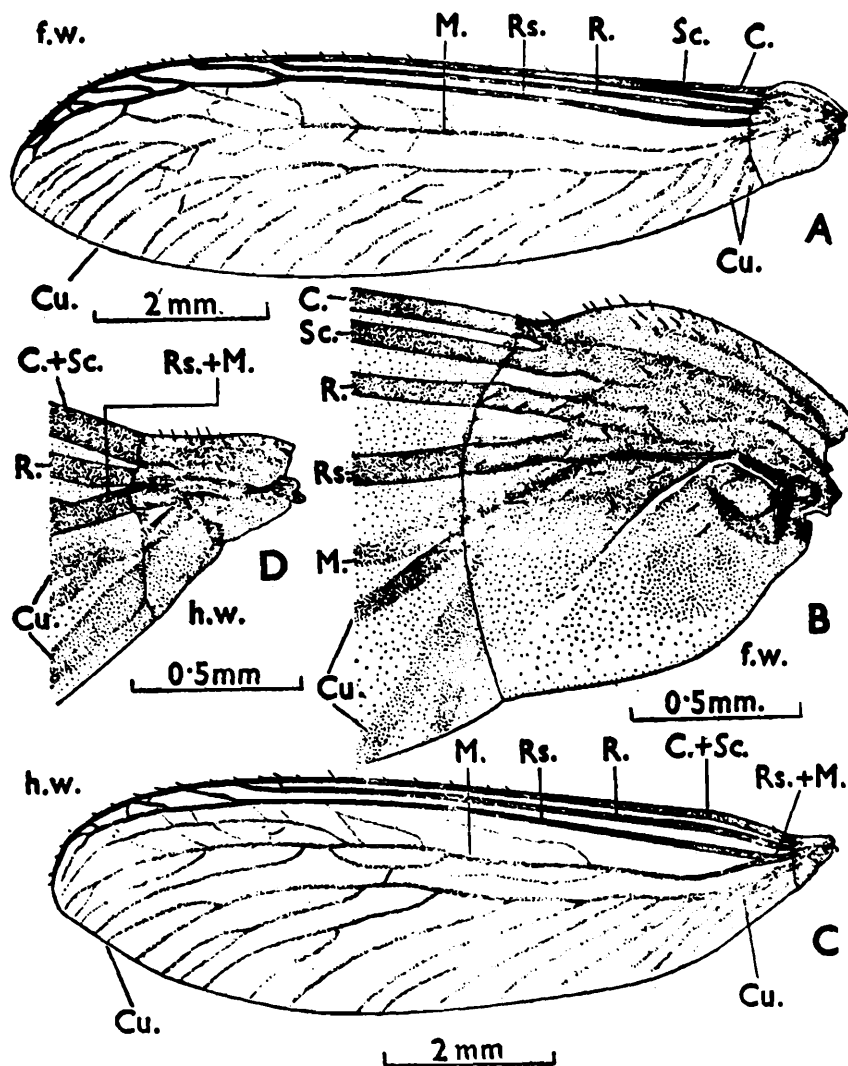

Fig. 185. *Bifiditermes beesoni*. Wings. (A) Left forewing. (B) Same, proximal part enlarged. (C) Left hindwing. (D) Same, proximal part enlarged. C., costa; Cu., cubitus; f.w., forewing; h.w., hindwing; M., media; R., radius; Rs., radial sector; Sc., subcosta. (After Roonwal and Sen-Sarma, 1960).

**SOLDIER** (Fig. 186) Head-capsule reddish brown, pale brown in anterior and posterior regions; antennae proximally dark brown, distally paler; labrum brownish; postmentum darker; thorax and legs pale brown; abdomen pale straw coloured. Head and body fairly densely pilose with short hairs. Total length c 7.4-9.5 mm. Head-capsule rectangular, much longer than broad (length to base of mandibles 2.02-2.47, width 1.57-1.95 mm); sides subparallel, slightly converging in front; frons sloping in front, with a median depression extending backwards to middle of head; Y-suture indistinct. Eyes small, oval ( length 0.15-0.23 mm); black; lying close to antennae, eye-antennal distance 0.18 mm, almost subequal to maximum diameter of eye. Ocelli absent. Antennae with 11-14 segments; antennal carinae large, upturned, covering basal segment; segment 4-shortest; fairly pilose, pilosity increasing distally. Anteclypeus weakly developed, subtrapezoidal, apilose. Postclypeus subrectangular, dark, separated from frons by a transverse, narrow depression and with 2 pairs of hairs on anterior margin. Labrum tongue-shaped to pear-shaped, much broader than long (width 0.45-0.55, length 0.25-0.35 mm); anterior margin and body pilose with short hairs; anterior margin either pointed or round. Mandibles fairly long, robust basally humped; about two thirds length of

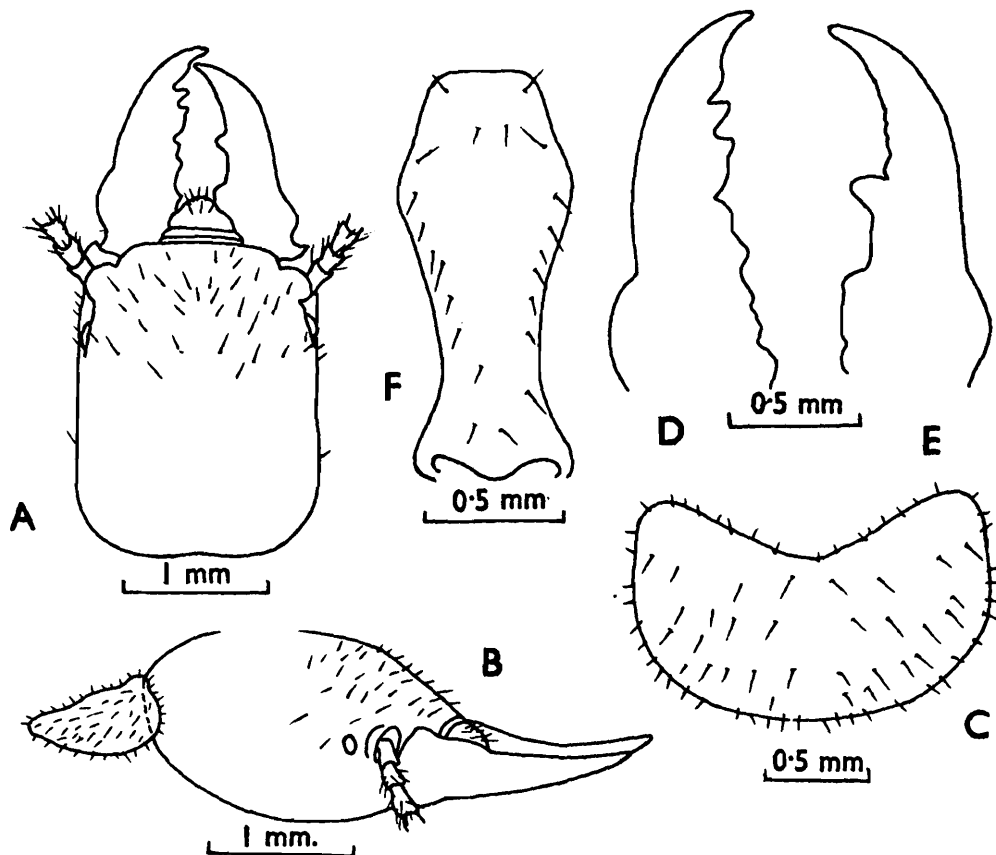

Fig. 186. *Bifiditermes beelsoni*. Soldier. (A) Head, in dorsal view. (B) Head and pronotum, in side view. (C) Pronotum. (D) and (E) Left and right mandibles. (F) Postmentum. (Redrawn from Roonwal and Sen-Sarma, 1960).

head to base of mandibles (length 1.4-1.5 mm). Left mandible with 4-5 marginal teeth. Right mandible with 2 marginal teeth. Postmentum short to long, club-shaped (median length 1.4-1.6 mm); broadest in anterior one-third (maximum width 0.55-0.70 mm); from whence narrowing anteriorly to a broadly subconvex anterior margin and posteriorly to a narrower waist (width at waist 0.30-0.35 mm) and then again broadening out to a fairly convex posterior margin. Pronotum subrectangular, fairly densely pilose with short hairs; anterior margin deeply concave, without a median notch; antero-lateral angles rounded; posterior margin substraight. Legs slender, short, pilose; apical tibial spurs 3:3:3; tarsi 4-segmented. Abdomen elongate, each tergum with 2 rows of hairs; cerci short, 2-segmented.

**PSEUDOWORKER** : Head-capsule straw-coloured; labrum and antennae paler; mandibles deep-straw coloured, inner margins dark brown; pronotum, legs and body yellowish white. Head and body fairly pilose. Total length 6.5-7.0 mm. Head-capsule subcircular, length subequal to width (width 1.4-1.5 mm, length 1.3-1.4 mm). Eyes rudimentary, small, black, sub-circular, flush with head-surface. Ocelli absent. Antennae 13 to 15-segmented, pilose; segments 3-5 subequal, shortest. Anteclypeus trapezoidal, whitish, fairly large. Postclypeus subrectangular, darker than frons and with a few short hairs at anterior margin. Labrum and mandibles as in imago. Pronotum subrectangular (width 1.6-1.7, length 0.70-1.00 mm), densely pilose; anterior margin concave; posterior margin convex. Legs and abdomen as in soldier.

**Distribution** : INDIA : Uttar Pradesh (Haldwani/ type-locality), Gorakhpur, Ramnagar. Haryana (Karnal). PAKISTAN : Lahore, Mianwali, Bhakkar, Muzaffargarh, Bahawalpur, Multan.

**Biology** : The nest of this species is in the form of small, narrow, longitudinal galleries which are filled with dry, compressed, loose faecal pellets similar to those found in *Cryptotermes* species. The species has been reported from a number of trees including ber (*Zizyphus jujuba*) and apple trees, but is not a serious pest. In a laboratory colony, emergence of alates was recorded during the months of June to August. The alates, soldiers and pseudoworkers are in the ratio of 1:5:94 and reproduction by constant parthenogenesis is reported (Chhotani 1962 a, b).

**49. Bifiditermes pintoï (Kemner)**  
(Figs. 187-189)

1. *kalotermes pintoï* Kemner :

1932. Kemner, *Ent. Tidskr.*, 53(2-3) : 143-146. Im, S. Lectotype (selected Roonwal and Sen-Sarma, 1960) : S, in Entomologiska Avdelningen, Zoological Institute, Lund University, Lund (Sweden). Type-locality : Talawila near Puttalam, Sri Lanka.

1949. Snyder, *Smiths. misc. Coll.*, 112: 19.

1960. Roonwal and Sen-Sarma, *Contr. Syst. Oriental Termites* (ICAR Ent. Monogr. 1) : 101, 102, 129-134; pls. 25, 26. (Synonymy, descriptions, etc.)

2. *Bifiditermes pintoï* (Kemner) :

1961. Krishna, *Bull. Am. Mus. nat. Hist.*, 122(Art. 4) : 369.

1975. Chhotani, *Zool. Anz.*, 194(1/2) : 114, 117, 119.

1982. Bose and Das, *Rec. zool. Surv. India*, 80: 197, 199, 210. table 2.

1987. Bose and Das, *Fauna of Orissa. State Fauna Ser.*, 1: 103.

See Roonwal and Sen-Sarma (1960) also for synonymy.

IMAGO (Figs. 187, 188) : Head-capsule yellow to straw coloured; antennae yellow to pale yellow; labrum straw-coloured; mandibles deep straw-coloured at base, deep brown elsewhere; pronotum, tibiae, tarsi and abdomen above yellow; femora and abdominal sternites yellowish white. Head and body fairly pilose. Total body length with wings c 10.5-11.5, without wings c 6.2-7.5 mm. Head-capsule subrectangular; moderately pilose with short hairs; length to base of mandibles (1.05-1.20 mm) subequal to maximum width including eyes (1.16-1.20 mm); in side view arched above in middle; frons gently sloping in front and without a median depression; Y-suture absent. Eyes black, large, subcircular, maximum diameter including ocular sclerite 0.4-0.5 mm; lying close to antennae; minimum eye-antennal distance 0.013-0.025 mm; Ocelli whitish, small (maximum diameter 0.20-0.22 mm), oval, translucent; broadly touching ocular sclerite. Antennae with 15-17 segments, segment 3 longer than 2 in 15 to 16-segmented antennae and subequal to 2 in 17-segmented one. Anteclypeus trapezoidal, whitish, apilose; postclypeus subrectangular, pilose, darker than frons. Labrum anteriorly sparsely pilose; squarishly hexagonal with sides pointedly bulging out in middle and narrowing anteriorly and posteriorly to flattened broad margins. Mandibles as in genus. Pronotum subrectangular, a little broader than head (length 0.80-

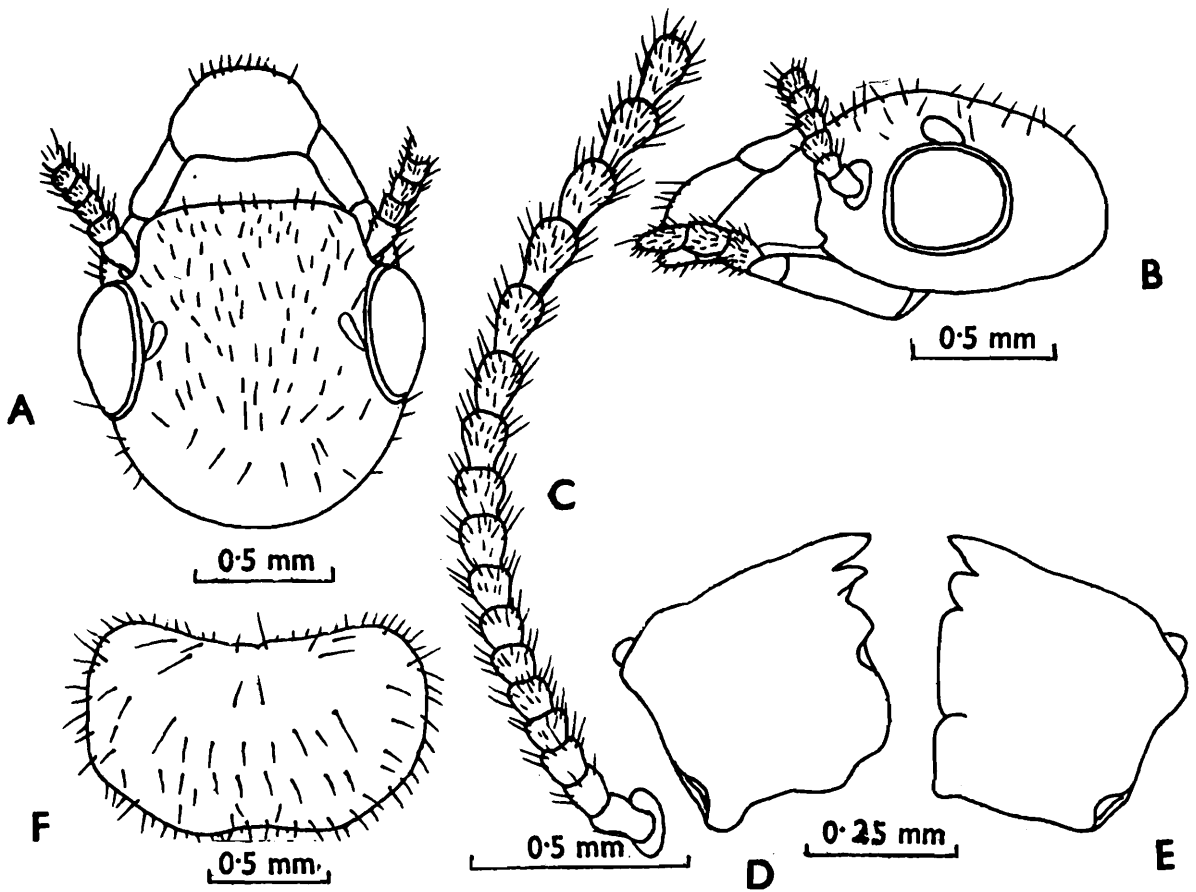

Fig. 187. *Bifiditermes pintoii*. Imago. (A) Head, in dorsal view. (B) Same, in side view. (C) Antenna. (D) and (E) Left and right mandibles. (F) Pronotum. (Redrawn from Roonwal and Sen-Sarma, 1960).

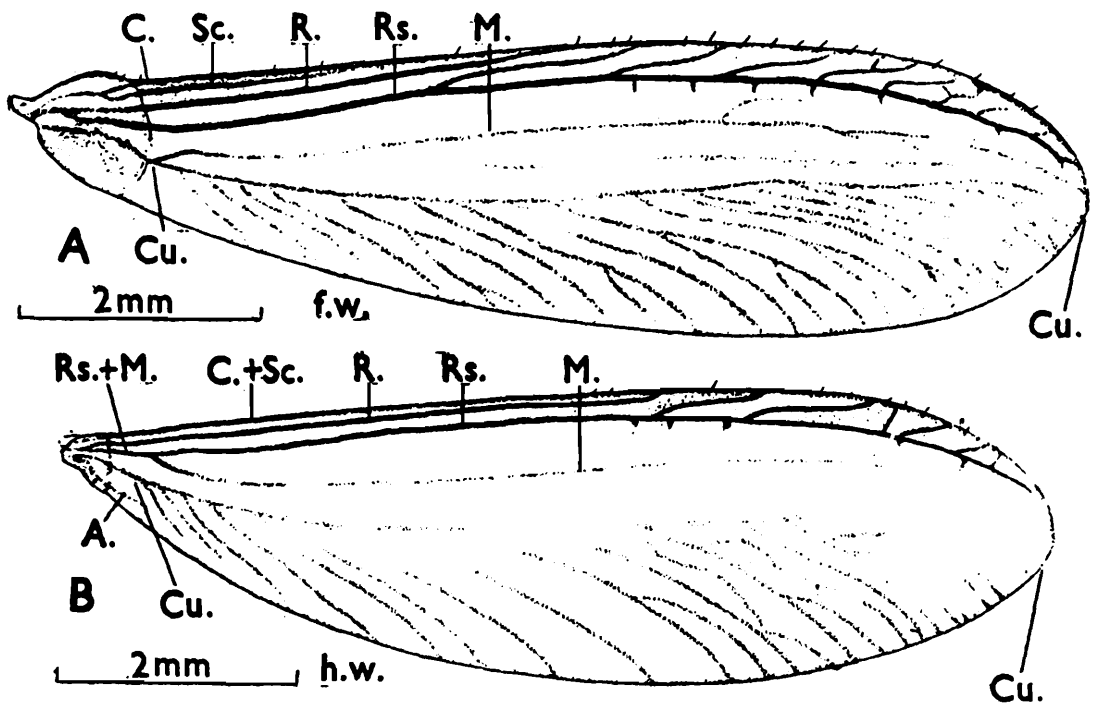

Fig. 188. *Bifiditermes pintoii*. Wings. (A) Right forewing. (B) Right hindwing. Lettering same as in fig. 185. (After Roonwal and Sen-Sarma, 1960).

0.85, width 1.27-1.45 mm); anterior margin weakly concave, not notched medially; posterior margin substraight with a weak median incurving. Legs short, slender, apical tibial spurs 3:3:3; tarsi 4-jointed; arolium absent. Wings whitish, neither tuberculate nor hairy. Forewing : Wing venation as in *beesoni* except subcosta shorter, meeting costa at about 1/6 of wing-membrane; radius stopping short and meeting costa before middle; radial sector with 6-8 branches to costal border; media arising from cubitus generally outside scale (occasionally inside scale); and cubitus with 10-13 branches to posterior border. Hindwing : Venation as in *beesoni* except radial sector with 5-6 branches to costa beyond middle and cubitus with 15-18 branches to posterior margin. Abdomen elongate, hairy; cerci short, 2-jointed.

**SOLDIER (Fig. 189)** Head reddish brown anteriorly, yellowish brown posteriorly; antennae brown basally, yellowish distally; mandibles black, reddish brown basally; pronotum pale brown to brown; legs paler; abdomen whitish. Head and body moderately hairy. Total body-length c 7.4-8.5 mm. Head-capsule subrectangular, much longer than wide (length to base of mandibles 2.0-2.28, width 1.55-1.60 mm); sides subparallel; frons gently sloping in front, with a median depression extending behind upto middle of head; Y-suture indistinct. Eyes small, oval, blackish, 0.20-0.22 mm in long diameter; slightly raised from head-surface; situated from antennae at a distance of about their long diameter (0.18-0.20 mm). Ocelli absent. Antennae 13-segmented; segment 3, long, club-shaped and strongly chitinised; antennal carina well developed, projecting and strongly sclerotised. Anteclypeus trapezoidal, apilose, translucent, postclypeus subrectangular, with 2 pairs of hairs anteriorly and not clearly differentiated from frons. Labrum short, semicircular; medially projecting in front a little; with a few hairs on tip and body. Mandibles long (1.25-1.30 mm), stout and basally humped at outer margin; about 2/3 of length of head to base of mandibles. Left mandible with 5 and right with 2 marginal teeth. Postmentum club-shaped, 1.55-1.70 mm long; anterior broader portion about half of total length and weakly to moderately bilobed whence narrowing behind to a narrow waist about half of maximum width; width at broader portion 0.60 and at waist 0.25-0.30 mm. Pronotum subrectangular; wider than long and a little wider than head (width 1.60-1.75, length 1.10 mm); anterior margin strongly, angularly or gradually incurved; antero-

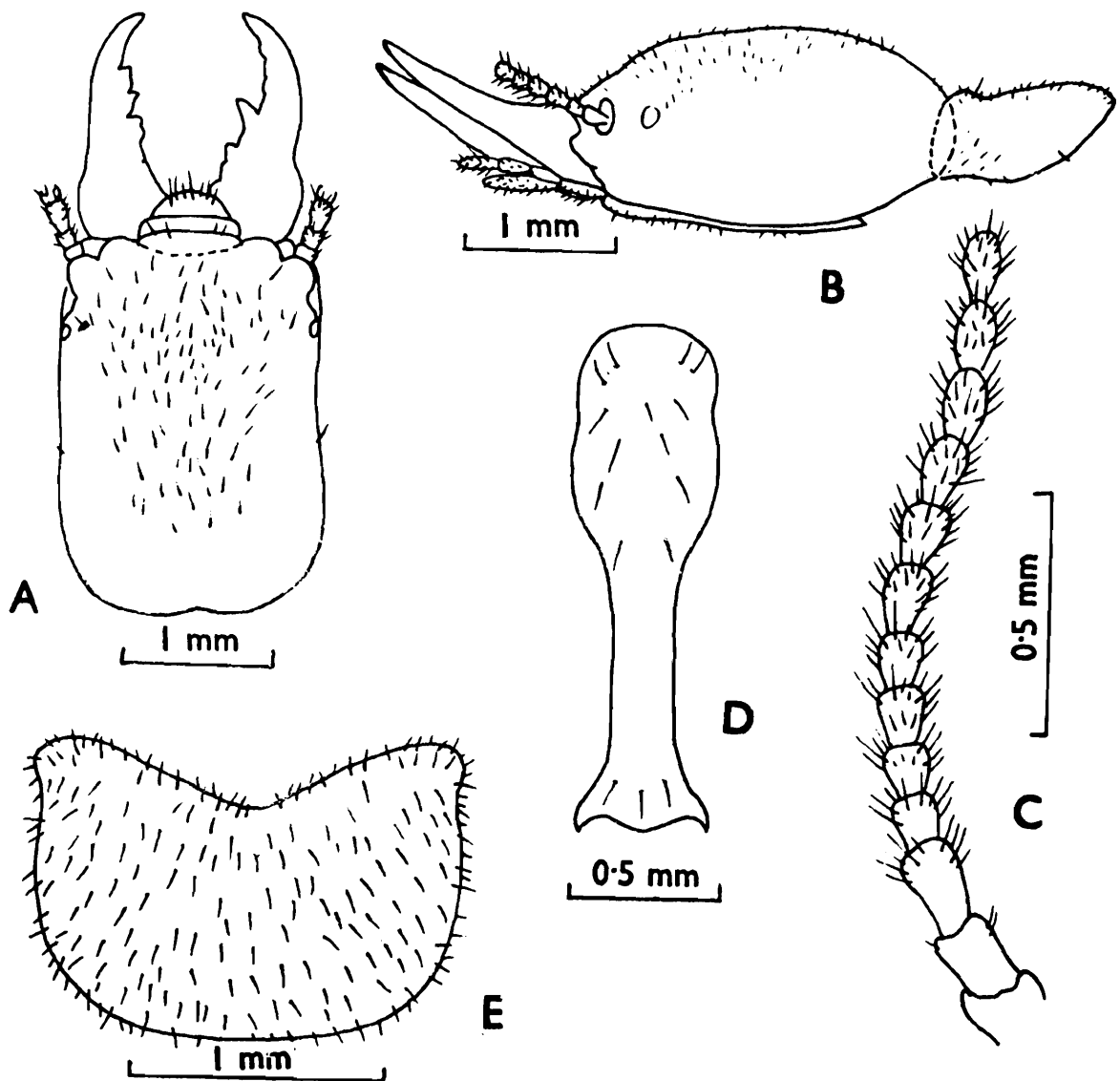

Fig. 189. *Bifiditermes pinto*. Soldier. (A) Head, in dorsal view. (B) Head and pronotum, in side view. (C) Antenna. (D) Postmentum. (E) Pronotum. (Redrawn from Roonwal and Sen-Sarma 1960).

lateral angles sharp, narrower than postero-lateral angles; posterior margin substraight to subconvex. Legs short, slender and hairy; femora moderately swollen; tibial spurs 3:3:3; tarsi 4-jointed. Abdomen elongate; each tergum with 2 rows of hairs; cerci short, 2-jointed.

**PSEUDOWORKER** : Head pale straw-coloured; rest of body and legs whitish with yellowish tinge. Head and body moderately hairy. Total body-length c 6.0-7.5 mm. Head-capsule subcircular (length to base of

mandibles 1.20, width 1.30-1.40 mm); frons gently sloping in front and with a shallow depression medially. Eyes rudimentary, small, black, flush with head-surface. Antennae 14-segmented; segment 3 either subequal to or longer, squarish with rounded sides. Mandibles as in genus. Pronotum subrectangular; anteriorly broadly concave and posteriorly convex. Legs and abdomen as in soldier.

*Distribution* : SRI LANKA Talawila near Puttalam (type locality). India Barkuda Island (Chilka Lake, Orissa).

### Genus 10. *Epicalotermes* Silvestri

#### *Epicalotermes* Silvestri

1918. Silvestri, *Boll. Lab. Zool. Gen. Agr. Portici*, 12: 347.
1949. Snyder, *Smiths. misc. Colls.*, 112 : 12.
1961. Krishna, *Bull. Am. Mus. nat. Hist.*, 122 (Art. 4) : 315, 316, 317, 374-376, 384, 385, 388, 389. (Detailed synonymy, generic characters and species included.)
1962. Krishna, *Am. Mus. Novit.*, No. 2119 : 9.
1965. Bouillon and Mathot, *Zooleo*, No. 1: 18, 39, table generic measurements.
1970. Krishna, In *Biology of Termites* (eds. Krishna and Weesner) : 133.
1971. Bouillon and Mathot, *Zooleo*, No. 1 (Suppl. 2) : Table gen. measurements.
1972. Coaton and Sheasby, *Cimbebasia*, No. 2: 21, 22, 23, 46, 49, 101.
1972. Chaudhry and Ahmad, *Termites of Pakistan* (Final Tech. Rep. PL 480 Proj.): 5.
1974. Akhtar, *Pakistan J. Zool.*, 6(1 & 2) : 88, 89, 96, 100.
1975. Ruelle, *Ent. Mem. Dep. Agric. Tech. Serv.*, No. 45 : 2-3.
1977. Roonwal, *Proc. zool. Soc., Calcutta*, 28(1975) : 32, 34.
1983. Roonwal, *Proc. Indian natn. Sci. Acad.*, (B) 49(5) : 362.
1986. Grassé, *Termitologia*, Vol. 3: 510.

Type of genus : *Epicalotermes aethiopicus* Silvestri

#### 1. *Characters of Genus Epicalotermes*

*Imago* : Head brownish yellow to yellowish brown; antennae brownish yellow to pale brown; pronotum paler than to as dark as head; legs whitish to pale yellow. Head with a few scattered hairs; pronotum with bristles along margins and on body. Head-capsule semicircular behind eyes; Y-suture present. Eyes broadly oval, of medium size, diameter 0.35-0.55 mm.

Ocelli oval, touching eyes. Antennae 14-19 segmented; 3rd segment variable, either equal to or longer than 2nd. Mandibles each with an apical and two marginals; left mandible with anterior margin of second marginal (third of some authors) about one-and-a-half times that of posterior margin of first (first + second of some) and first marginal shorter at base than second; right mandible with molar plate shorter than posterior margin of second marginal. Pronotum slightly narrower to slightly broader than head with eyes; anterior margin incurved; posterior margin straight or slightly to distinctly emarginate. Wing-membrane clear, covered with pimpules (papillae of Krishna, 1961). Costa, subcosta, radius and radial sector strongly developed and sclerotised; media and cubitus weak and unsclerotised. Forewing: Costa, subcosta, radius and radial sector arising independently from scale, media and subcosta arising from a common stalk in wing-membrane. Costa running along anterior margin; subcosta short meeting costa just outside scale; radius meeting costal border before middle of wing-membrane; radial sector with 5-9 branches to costal border; media running medially up to distal tip, may be simple or forked; cubitus with a number of branches to posterior border. Hindwing: Venation as in forewing except for absence of subcosta and arising of media from radial sector in wing membrane. Tibial spurs 3:3:3; tarsi 4-jointed; arolium absent.

*Soldier* : Head brownish to reddish brown, darker anteriorly; body pale brownish yellow. Head-capsule subrectangular, dorso-ventrally flattened; sides weakly converging anteriorly; frons sloping in front gradually and depressed medially; antennal carinae prominent; Y-suture present. Eyes large, oval, pigmented. Ocelli absent. Antennae with 10-13 segments; 3rd segment highly sclerotised, longest, club-shaped. Mandibles long, stout and robust; having prominent basal humps and strongly curved. Left mandible with 5 marginal teeth; 1st and 2nd marginals prominent, remaining ones weakly developed; right with 2 large marginals. Labrum subrectangular, broader than long; anterior margin with a small, median projection. Pronotum flat, subrectangular, as broad as or slightly narrower than head; anterior margin slightly raised, deeply and angularly incurved and indented medially; sides substraight. Tibial spurs 3:3:3; tarsi 4-jointed.

2. *Distribution and Composition of Epicalotermes*  
(Fig. 190)

Only six species of the genus are known, of which four occur in Ethiopian, one in Malagasy and one (i.e. *E. pakistanicus* Akhtar) in Oriental, regions.

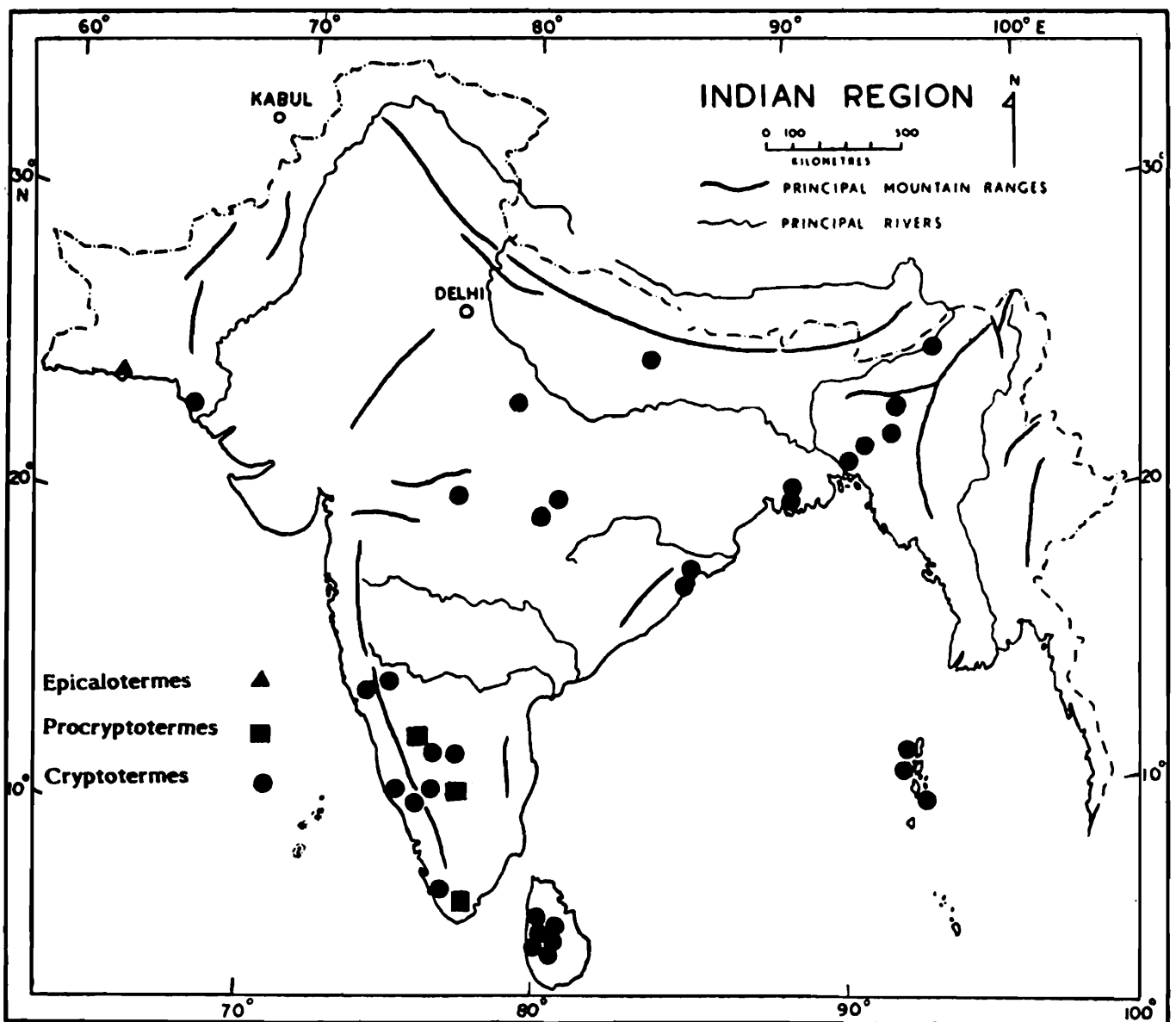

Fig. 190. Map of the Indian Region, showing distribution of the genera, *Epicalotermes*, *Procryptotermes* and *Cryptotermes* (Kalotermitidae).

**50. *Epicalotermes pakistanicus* Akhtar**  
(Figs. 191, 192)

1. *Epicalotermes pakistanicus* Chaudhury and Ahmad :

1972. Chaudhry and Ahmad, *Termites of Pakistan (Final Tech. Rep. PL 480 Proj.)*: 6. (Nom. nud.)

2. *Epicalotermes pakistanicus* Akhtar :

1974. Akhtar, *Biologia* (Lahore), 20(1): 29-33. Im, S. Holotype: S, in Zool. Dept. Panjab University, Lahore (Pakistan). Type-locality : Gwadar, Baluchistan, Pakistan.

1974. Akhtar, *Pak. J. Zool.*, 6(1 & 2) : 101.

**IMAGO (Fig. 191) :** Head yellowish brown, with a pale V-shaped impression in front of Y-suture; anteclypeus light brown; pronotum slightly

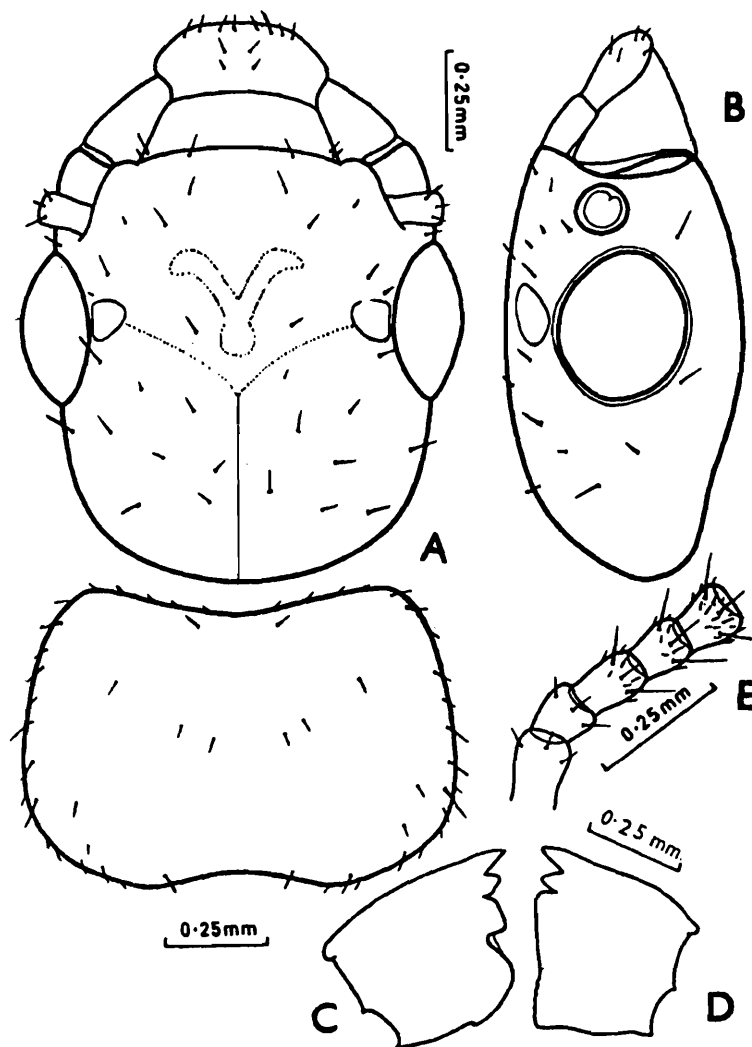

**Fig. 191.** *Epicalotermes pakistanicus*. Imago. (A) Head and pronotum, in dorsal view. (B) Head, in side view. (C) and (D) Left and right mandibles. (E) Basal part of antenna. (After Akhtar 1974a).

paler to as dark as head; coxae and femora whitish, tibiae and tarsi light brown; wing membrane clear, costa, subcosta, radius, and radial sector sclerotised, media and cubitus light brown, not strongly sclerotised. Head sparsely pilose, with few long and short hairs; labrum with a few hairs on anterior margin and on middle of body; pronotum also with a few hairs on margins and on body; wings with a few hairs along costal margin. Head-capsule parallel-sided; length to base of mandibles 0.94-1.17, maximum width 1.10-1.22 mm; semicircular behind eyes. Y-suture distinct; Eyes large, oval; long diameter 0.38-0.45. Ocelli oval; length 0.14-0.17, width 0.09-0.11 mm; almost touching eyes. Antennae 15-16 segmented; segment 3 longer than 2 or 4; 4 slightly shorter than 3. Anteclypeus trapezoidal. Labrum much broader than long, anteriorly convexical. Mandibles as in genus. Pronotum as broad as or a little broader than head; width 1.11-1.35, maximum length 0.70-0.79 mm; anterior margin weakly concave; sides slightly convexical; posterior margin strongly emarginate. Wing membrane clear, venation as in genus. Apical tibial spurs 3:3:3; tarsi 4-jointed; arolium absent.

**SOLDIER (Fig. 192)** : Head yellowish brown, anteriorly darker; postclypeus, antennal carinae and labrum light brownish red; mandibles basally reddish brown, apically blackish; antennae yellowish brown, basally pale brownish red; pronotum light reddish brown; legs yellowish brown to pale brown; abdomen pale brownish yellow. Head sparsely pilose with short and long hairs; labrum with a few hairs on anterior margin and on body; postmentum with a few bristles in anterior half and short hairs all over body; pronotum with a few hairs on margins and on body. Head-capsule dorso-ventrally flattened, longer than broad; length to mandible-base 1.94-2.44, width 1.61-1.93 mm; sides weakly convexical, converging anteriorly; posterior margin weakly emarginate; Y-suture distinct; frons sloping anteriorly, medially depressed. Eyes large; long diameter 0.20-0.28, short diameter 0.10-0.22 mm; oval to weakly triangular, pigmented. Antennae with 12-13 segments; segment 4 shortest; 3 long, strongly sclerotized. Labrum much broader than long, subparallel sided; anterior margin produced into a tip. Mandibles stout, strongly curved, inward from basal humps to apex; basal humps well developed; length more than half of head-length to base of mandibles. Left mandible 1.44-1.77 mm long; with two well developed and three weakly developed marginal teeth. Right mandible with

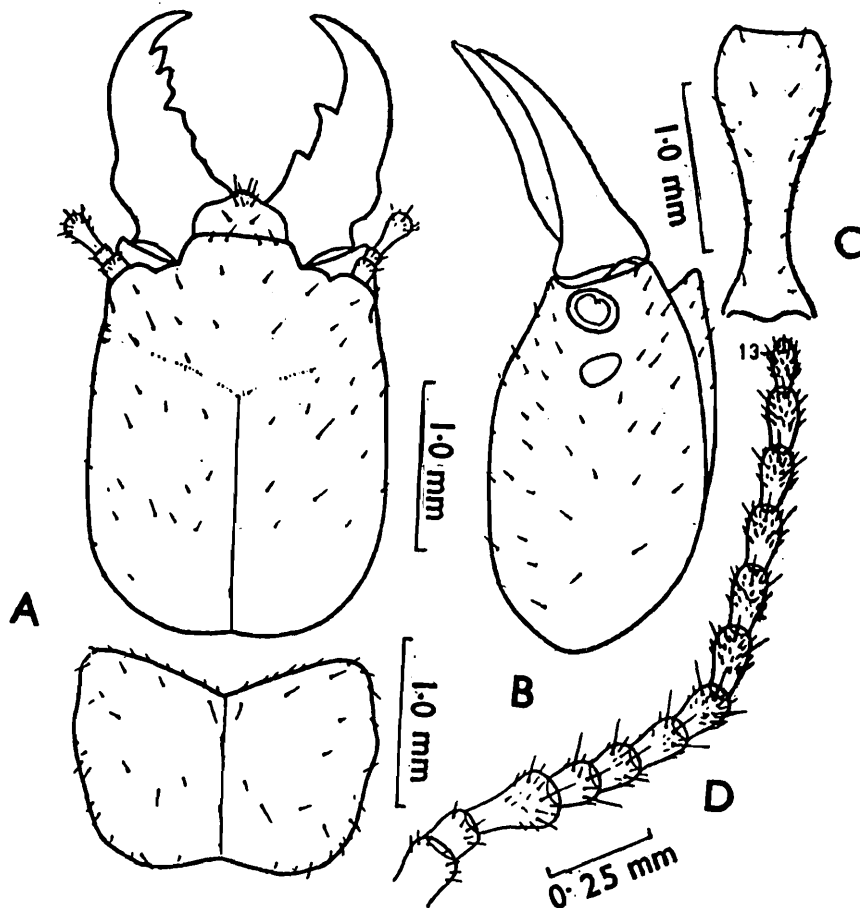

Fig. 192: *Epicalotermes pakistanicus*. Soldier. (A) Head and pronotum, in dorsal view. (B) Head, in side view. (C) Postmentum. (D) Antenna. (After Akhtar 1974a).

two widely separated marginal teeth. Postmentum long, club-shaped; length 1.29-1.81 mm; widest anteriorly, maximum width 0.58-0.74 mm; narrowest a little below middle, minimum width 0.25-0.28 mm. Pronotum subrectangular, as wide as or little narrower than head, (width 1.64-1.87, length 0.93-1.06 mm); anterior margin deeply and angularly concave and slightly raised; sides slightly wavy near about middle, posteriorly weakly convergent; posterior margin distinctly emarginate. Apical tibial spurs 3:3:3; tarsi 4-jointed; arolium absent.

*Distribution* : PAKISTAN : Gwadar, Baluchistan.

### Genus 11. *Procryptotermes* Holmgren

1. Subgenus *Procryptotermes* (of *Calotermes*) Holmgren :  
1910. Holmgren, *Zool. Anz.*, 35: 285. (No description).

1910. Holmgren, *Trans. Linn. Soc. London (Zool.)*, (2) 14(8) : 139.
2. Genus *Procryptotermes* Holmgren :
1949. Snyder, *Smiths. misc. Colls.*, 112: 36.
1961. Krishna, *Bull. Am. Mus. nat. Hist.*, 122 (Art. 4) : 314, 315, 316, 317, 376-378, 384, 385, 388, 389. (Synonymy, characters and species included).
1962. Krishna, *Am. Mus. Novit.*, No. 2119 : 13.
1963. Roonwal & Chhotani, *Biol. Zbl.*, 82: 265-267.
1973. Chhotani and Bose, *Zool. Anz.*, 190(3/4) : 233.
1975. Chhotani, *Zool. Anz.*, 194(1/2) : 114-115, 117, 119, 121, 122.
1975. Sen-Sarma et al., *Wood Destroying Termites of India (Final Tech. Rept. PL 480 Progr.)* : 7, 36.
1975. Thakur, *Indian Acad. Wood Sci. J.*, 6(1): 29.
1984. Bose, *Occ. Pap. Rec. zool. Surv. India*, No. 49 : 56.
1986. Grasse, *Termitologia* Vol. 3: 510.

Type of genus : *Procryptotermes fryeri* Holmgren

### 1. Characters of Genus *Procryptotermes*

**Imago** : Reddish brown to deep castaneous brown. Head-capsule subrectangularly oval, almost as broad as length to base of mandibles; Y-suture variably distinct or absent. Eyes oval 0.29-0.39 mm in maximum diameter; anteriorly rounded or straight. Ocelli small, oval, 0.08-0.10 mm in length; either touching or very close to eyes. Antennae 16-18 segmented; segments 3-5 variable in length. Labrum broadly tongue-shaped. Anteclypeus subtrapezoidal, translucent, apilose. Postclypeus narrow, flat, faintly demarcated from frons. Mandibles each with an apical and two marginal teeth; anterior margin of 2nd (3rd of some authors) marginal of left mandible about one-and-a half times that of posterior margin of 1st (1st plus 2nd of some); molar plate of right mandible shorter than posterior margin of 2nd marginal. Pronotum as broad as or broader than head; variably incurved at anterior margin and substraight or faintly incurved at posterior margin. The veins costa, subcosta (absent in hindwing), radius and radial sector thickly chitinised; media and cubitus weak; all veins arising independently from scale in forewing; radius without branches, meeting costa before middle; radial sector with 4-5 branches and running upto distal

end; media curving up and meeting radial sector beyond middle, arising from radial sector in wing-membrane in hindwing; cubitus with 11-12 branches to posterior margin. Legs short, stout, apical tibial spurs 3:3:3; tarsi 4-jointed; arolium present. Abdomen oblong, cerci 2-jointed; styli single-jointed.

*Soldier* : Head subrectangular, long; sides substraight or weakly convex; with a weak to prominent, medial depression between frons and vertex; frons sloping in front at 45° angle; with a prominent horn-like projection of ventral genae on either side and another horn-like projection on either side of postclypeus either present or absent; Y-suture present or absent. Eyes small, oval, unpigmented. Ocelli absent. Antennae with 9-16 segments; segment 3 generally long and club-shaped, longer than 2 (shorter than 2 in *rapae*). Anteclypeus thin, narrow, strip-like; postclypeus flat; rectangular and either distinctly or faintly separated from frons. Labrum short and broad; sometimes medially tipped at anterior margin. Mandibles long, prominent and incurved distally; about 2/3rd to nearly 3/4th of head-length; basal hump at outer margin weak to fairly prominent. Both mandibles variably toothed or toothless. Postmentum club-shaped, with a narrow waist. Pronotum nearly as wide as or a little narrower than head; weakly to deeply incurved at anterior margin. Legs short and stout; femora weakly or not swollen; apical tibial spurs 3:3:3; tarsi 4-jointed. Abdomen oblong; cerci 2-jointed; styli single-jointed.

*Pseudoworker* : Pale creamy white to pale yellow; fairly pilose. Head-capsule subcircular. Eyes rudimentary, oval, unpigmented. Antennae 11-13 segmented. Mandibles as in imago. Pronotum subrectangular; narrower than head. Legs and abdomen as in soldier.

## 2. *Distribution and Composition of Procryptotermes* (Fig. 190)

Of the 10 species of the genus known from the world, 3 occur in Oriental (southern India), 3 in Papuan, one in Ethiopian, 2 in Malagasy and one in Neotropical regions.

The following 3 species are known from India :

1. *Procryptotermes dhari* Roonwal and Chhotani. India : Tamil Nadu.

2. *P. hunsurensis* Thakur. India : Karnataka.

3. *P. valeriae* Bose India : Tamil Nadu.

### 3. Keys to Indian Region Species of *Procryptotermes*

#### IMAGOES

- |  |                    |
|--|--------------------|
| 1(2) Antennae strongly chitinised, brown; 2nd segment longer than 3rd.                   | <i>valeriae</i>    |
| 2(1) Antennae weakly chitinised, paler; 2nd segment shorter than 3rd                     |                    |
| 3(4) Smaller species : Head-length to base of mandibles 0.95 mm; head-width 0.95 mm..... | <i>dhari</i>       |
| 4(3) Larger species : Head-length to base of mandibles 1.05 mm; head-width 1.08 mm.....  | <i>hunsurensis</i> |

#### SOLDIERS

- |   |                    |
|---|--------------------|
| 1(4) Head with one antero-lateral, horn-like projection of ventral genae on either side.  |                    |
| 2(3) Right mandible with two weak crenulations in anterior half and a tooth at base.....  | <i>dhari</i>       |
| 3(2) Right mandible with 2 prominent marginal teeth in middle.....  | <i>hunsurensis</i> |
| 4(1) Head with two antero-lateral, horn-like projections on either side (one a projection of ventral genae and other a projection on either side of postclypeus)..... | <i>valeriae</i>    |

### 51. *Procryptotermes dhari* Roonwal and Chhotani (Figs. 193-195)

#### *Procryptotermes dhari* Roonwal and Chhotani

1963. Roonwal and Chhotani, *Biol. Zbl.*, **82**(3): 267-273. S, Pw. Holotype : S, in ZSI, Calcutta. Type-locality : Coimbatore, Tamil Nadu, India.
1975. Chhotani, *Zool. Anz.*, **194**(1/2): 114, 115, 117, 119, 122.
1975. Thakur, *Indian Acad. Wood. Sci. J.*, **6**(1): 36.
1979. Bose, *Bull. zool. Surv. India*. **2**(1): 58-59. Imago.
1984. Bose, *Occ. Pap. Rec. zool. Surv. India*, No. 49: 56, 57-58.
1986. Grassé, *Termitologia*, vol. 3: 517.

IMAGO (DEALATE) (Fig. 193) : Head-capsule, postclypeus and mandibles dark reddish brown; antennae, labrum and palpi deep golden yellow; thorax and abdomen dorsally darker, ventrally paler; legs pale

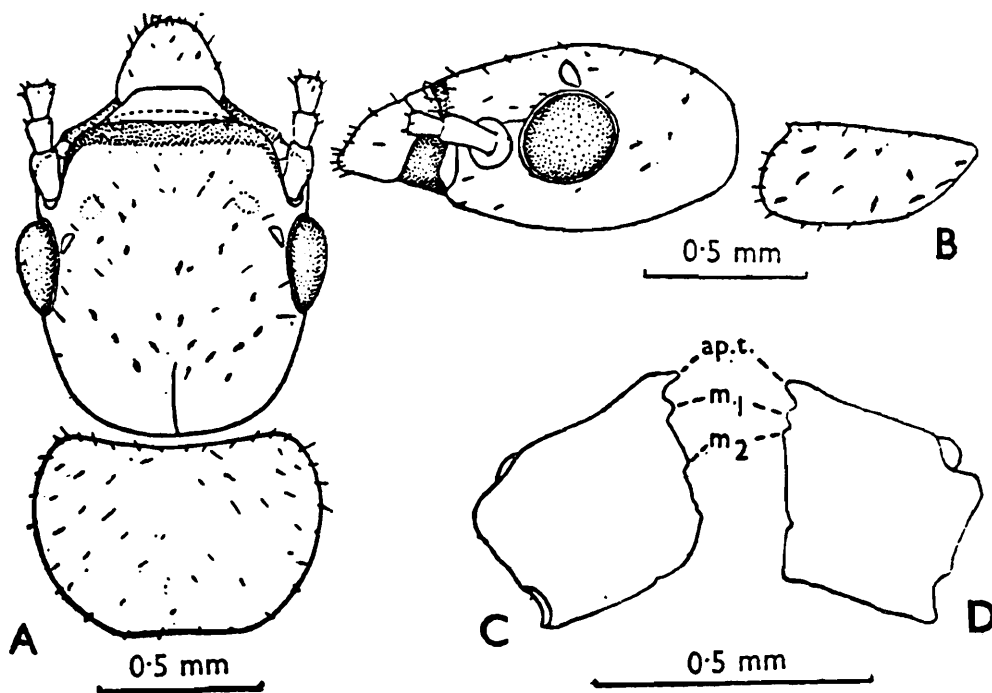

Fig. 193. *Procryptotermes dhari*. Imago. (A) Head and pronotum, in dorsal view. (B) Same, in side view. (C) and (D) Left and right mandibles.  
ap.t., apical tooth; m<sub>1</sub> and m<sub>2</sub>, first and second marginal teeth (After Bose 1979).

reddish-brown. Head and body fairly pilose with pale yellow pilosity. Total length (excluding wings) 4.90 mm. Head slender, oval; length to base of mandibles (0.95 mm) equal to head-width including eyes (0.95 mm); Y-suture present only as a longitudinal line in posterior region of head. Eyes large, oval (maximum diameter 0.29, minimum diameter 0.25 mm); situated close to antennae. Ocelli elongate, oval, small (long diameter 0.10, short diameter 0.06 mm); lying close to eyes (eye-ocellus distance 0.02 mm).

Antennae 8+-segmented; segments 4 and 5 subequal, shortest. Anteclypeus trapezoidal, hyaline, apilose. Postclypeus also trapezoidal, faintly demarcated from frons; with a few short hairs on anterior margin. Labrum broad, tongue-shaped (length 0.2, width 0.33 mm); with a cluster of hairs on anterior margin and anterior part of body. Mandibles as in genus. Pronotum flat, much broader than long (length 0.58, width 0.93 mm); as wide as head-width with eyes; with a few long and short hairs on margins and on body; anterior margin weakly concave; posterior margin substraight. Legs

short, stout, sparsely pilose; apical tibial spurs 3:3:3; arolium between claws present, pale yellow. Abdomen oval, strongly chitinized; cerci 2-jointed, 0.08 mm long; styli single-jointed, 0.06 mm long.

**SOLDIER** (Figs. 194, 195) Head-capsule dark brown anteriorly, paler posteriorly; antennae golden yellow, segment 3 darker; labrum yellowish, translucent; mandibles dark brown, posteriorly paler; pronotum brownish yellow; abdomen and legs yellow. Head and body moderately hairy. Total length c 6.15-6.65 mm. Head-capsule subrectangular, much longer than broad (length to base of mandibles 1.68-1.77, width 1.23-1.30 mm); sides substraight, incurved in front of antennae and then projecting out to form a horn-like process on either side, being a prolongation of ventral gena; frons sloping in front, separated from vertex by a prominent ridge; the ridge depressed medially to form a short shallow groove; posterior margin convex. Eyes small, oval, translucent; maximum diameter 0.13-0.14, minimum diameter 0.05-0.07 mm; lying close to antennae (eye-antennal distance

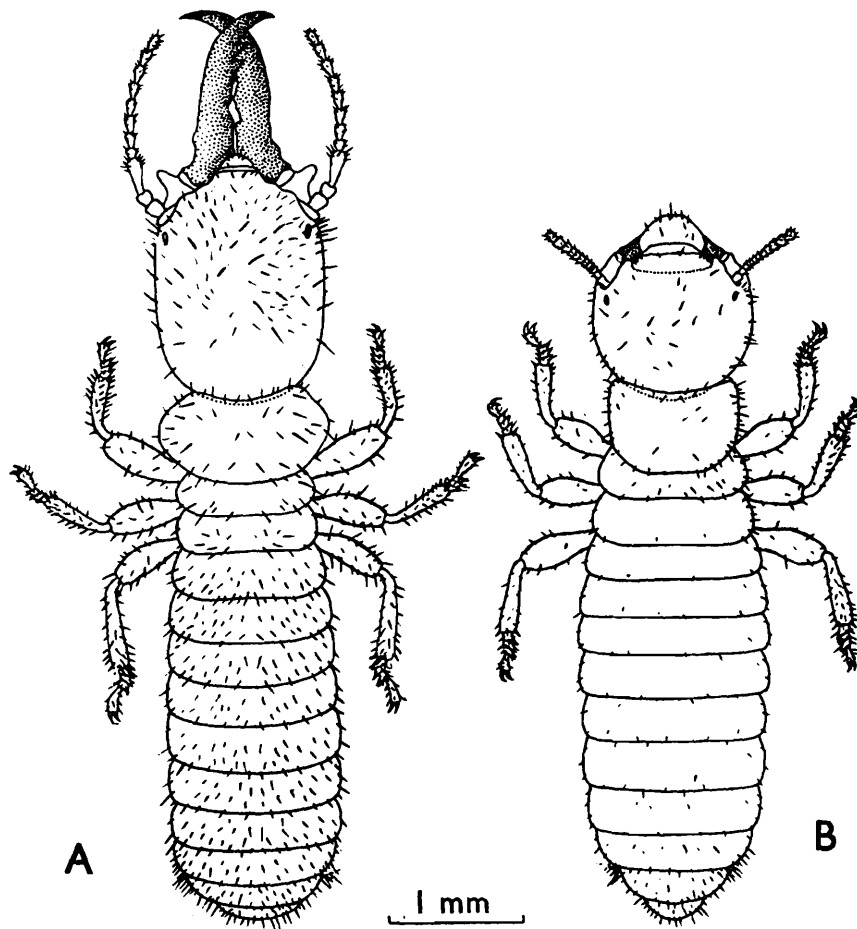

Fig. 194. *Procryptotermes dhari*. (A) Soldier. (B) Pseudoworker.

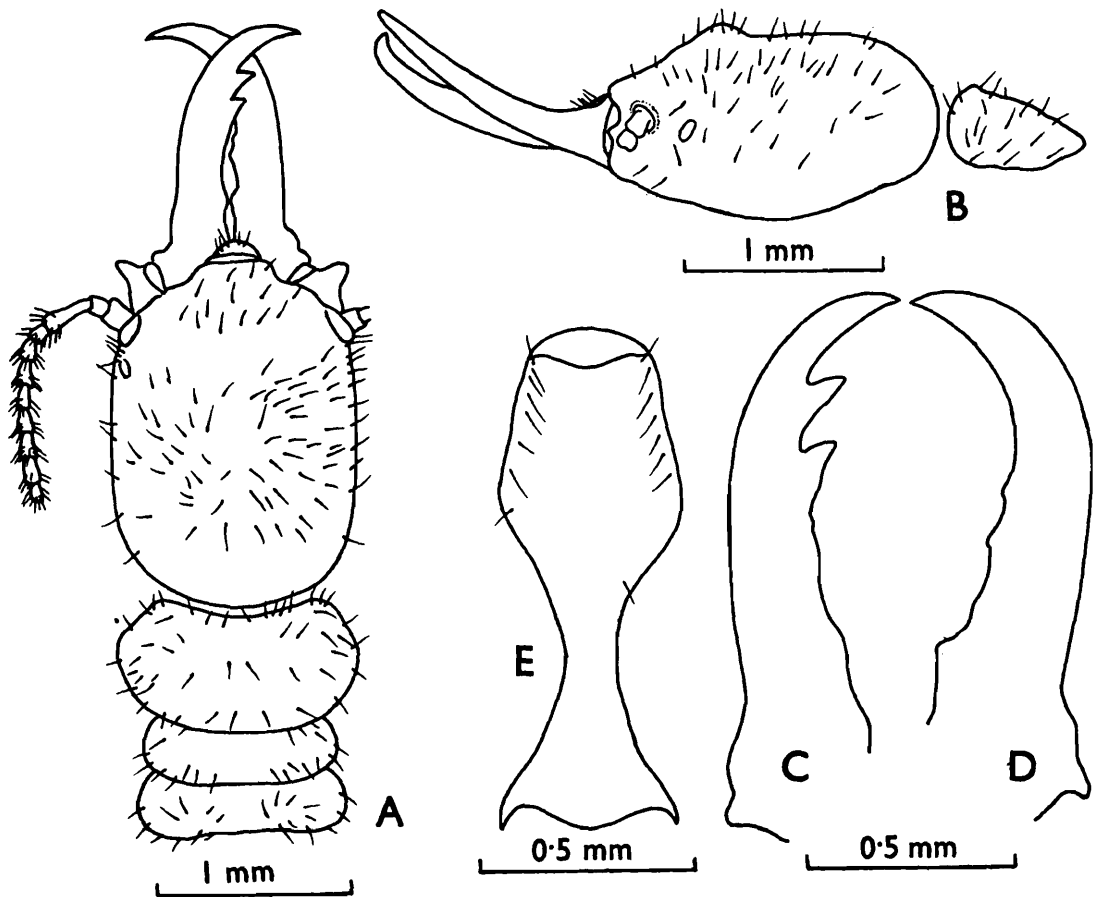

Fig. 195. *Procryptotermes dhari*. Soldier. (A) Head and thorax, in dorsal view. (B) Head and pronotum, in side view. (C) and (D) Left and right mandibles. (E) Postmentum.

0.10 mm). Ocelli absent. Antennae 11-segmented, segment 3 long, club-shaped, segment 4-shortest. Anteclypeus thin, apilose. Postclypeus trapezoidal, hardly separable from frons; with a few hairs on anterior part and body. Labrum much broader than long (length 0.10-0.17, width 0.30-0.33 mm); subrectangular, anterior margin weakly subconical; with 2 pairs of longish setae on anterior margin and a few shorter ones on body. Mandibles robust, long, with apices pointed and strongly incurved; length 1.17-1.23 mm; outer margin with a weak basal hump. Left mandible with 2 large robust marginal teeth and 1-2 crenulations in basal part. Right mandible with 2 weak crenulations in distal half and a sharp tooth near base. Postmentum fairly long, about 2/3rd of length of head-capsule (median length 1.13-1.18 mm); wineglass shaped, broadest in anterior half, with a narrow waist (maximum width 0.46-0.47, width at waist 0.15-

0.17 mm); a few hairs present in anterior half; a pair of long hairs present on convex anterior margin; posterior margin with a median bulge. Pronotum sparsely pilose; flat, much broader than long; subreniform, slightly narrower than head; sides convex, subrounded; anterior margin moderately concave; posterior margin subrounded. Mesonotum narrower than pronotum. Metanotum slightly broader than mesonotum but narrower than pronotum. Legs short; femora somewhat swollen and dark in colour; tibiae thin, apical tibial spur formula 3:3:3; tarsi 4-jointed. Abdomen elongate, pilose; cerci 2-jointed, 0.10-0.15 mm long; styli when present, one-jointed, 0.10 mm long.

**PSEUDOWORKER** (Fig. 194) Head capsule, antennae, labrum, clypeus and mandibles pale yellow; mandibular toothed margins dark brown; thorax and body pale yellowish white. Head and body moderately pilose. Total length 4.50-5.00 mm. Head subcircular, broader than length to base of mandibles (length 1.07-1.10, width 1.13-1.27 mm). Eyes rudimentary, small, oval (maximum diameter 0.13, minimum diameter 0.10 mm); translucent to pale brownish. Ocelli absent. Antennae very short, 11-12 segmented; segment 4 shortest. Anteclypeus subtrapezoidal, apilose. Postclypeus subrectangular, flat with a few hairs on margins. Labrum broadly tongue-shaped (length 0.28-0.33, width 0.40-0.47 mm); with a few hairs on anterior margin and body. Mandibles of typical *Procryptotermes* type. Pronotum subrectangularly crescentic shaped, broader than long (width 0.90-1.00, length 0.60 mm); narrower than head; anterior margin weakly concave; posterior margin substraight, with weak, medial depression. Mesonotum broader than pronotum; posterior margin substraight. Metanotum broader than mesonotum; posterior margin substraight. Legs and abdomen as in soldier.

*Distribution* : INDIA : Tamil Nadu : Coimbatore.

## 52. *Procryptotermes hunsurensis* Thakur (Figs. 196, 197)

*Procryptotermes hunsurensis* Thakur :

1975. Thakur, *Indian Acad. Wood. Sci. J.*, 6(1): 29-36. Im, S, Pw. Holotype : S, in FRI, Dehra Dun, India. Type-locality; Kalbetta, Hunsur (Karnataka, India).

1975. Sen-Sarma et al., *Wood Destroying Termites of India (Final Tech. Rept. PL 480 Programme)*; 51.

1979. Bose, *Bull. zool. Surv. India*, 2(1): 58.

1984. Bose, *Occ. Pap. Rec. zool. Surv. India*, No. 49 : 56, 57, 58-60.

IMAGO (DEALATE) (Fig. 196) : Head, thorax, wing-scales, femora and abdomen dark chestnut brown, sternites paler; antennae, mandibular base, labrum and legs yellowish brown. Head sparsely and body moderately hairy. Total length without wings 5.70 mm. Head-capsule subcircular (length to mandible-base 1.05, width 1.08 mm); sides, slightly convexical; posteriorly rounded; epicranial suture not visible. Antennae 8 + segmented;

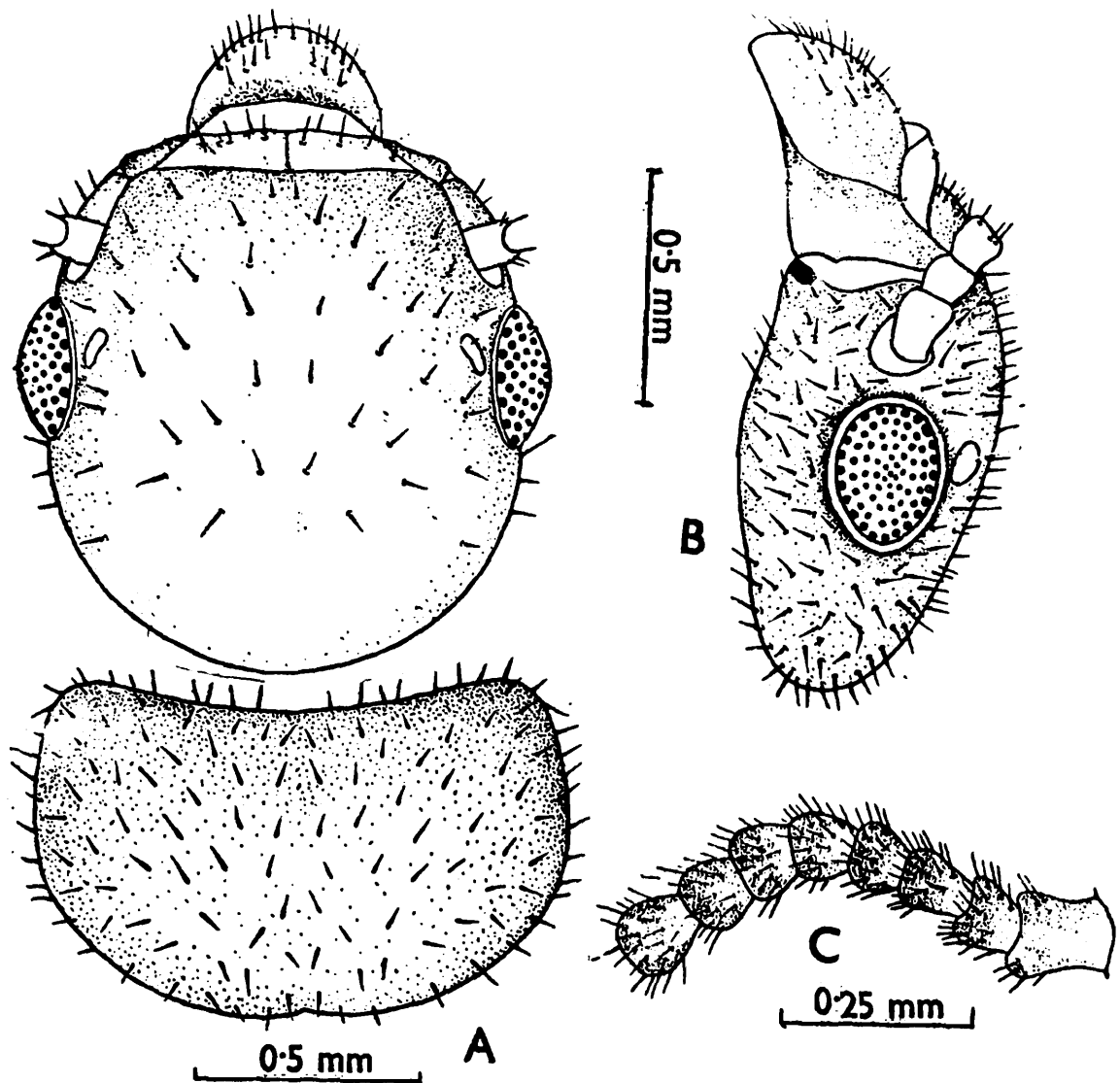

Fig. 196. *Procryptotermes hunsurensis*. Imago. (A) Head and pronotum, in dorsal view. (B) Head, in side view. (C) Basal part of antenna. (After Thakur, 1975a).

segment 4 shortest. Eyes suboval; maximum diameter 0.35, minimum diameter 0.28 mm; situated close to antennal sockets. Ocelli whitish, translucent, small, oval (maximum diameter 0.08, minimum diameter 0.06 mm); almost touching eyes. Anteclypeus whitish, apilose, with a weak, median tip. Postclypeus trapezoidal; indistinctly separated from frons; with a few hairs near anterior margin. Labrum dome-shaped, broader than long, anteriorly broadly rounded, with a few stout hairs near anterior margin and body. Mandibles as in genus. Pronotum flat, subrectangular, much broader than long and as broad as head (width 1.08, length 0.80 mm); anterior margin concave, sides sloping down to a rounded substraight, medially notched posterior margin. Forewing scale large, covering hindwing scale. Legs short, femora swollen, tibia thin; apical tibial spurs 3:3:3; tarsi 4-jointed; empodium present. Abdomen subcylindrical; cerci 2-segmented, 0.05 mm long.

**SOLDIER (Fig. 197) :** Head-capsule anteriorly brown to deep reddish brown, posteriorly paler; antennae golden yellow, basal segments chitinous and darker; labrum translucent, whitish; mandibles blackish brown, basally lighter; pronotum pale brownish; abdomen and legs yellow. Head sparsely and body moderately pilose. Total length c 5.60-7.30 mm. Head-capsule subrectangular, much longer than broad (length to base of mandibles 1.60-1.80, width 1.30-1.50 mm); sides substraight, converging anteriorly near base of antennae, then forming a horn-like projection on either side being projection of ventral gena; frons sloping in front, separated from vertex by a prominent, medially depressed ridge forming a short, shallow groove; epicranial suture prominent; posterior margin broadly rounded. Eyes close to antennae, small, oval (maximum diameter 0.15-0.20 mm; minimum diameter 0.05-0.13 mm), translucent. Ocelli absent. Antennae 9-12 segmented, moderately pilose; segment 4 shortest. Anteclypeus thin, narrow, translucent. Postclypeus trapezoidal, indistinctly separated from frons. Labrum subrectangular, much broader than long; anterior margin weakly, pointed medially. Mandibles long (left mandible length 1.15-1.25 mm); about two thirds of head-length to base of mandibles; stout with pointed incurved apices and outer margin with a hump near base. Left mandible with 2 large, prominent, subtriangular teeth in apical half and 1-2 small crenulations near

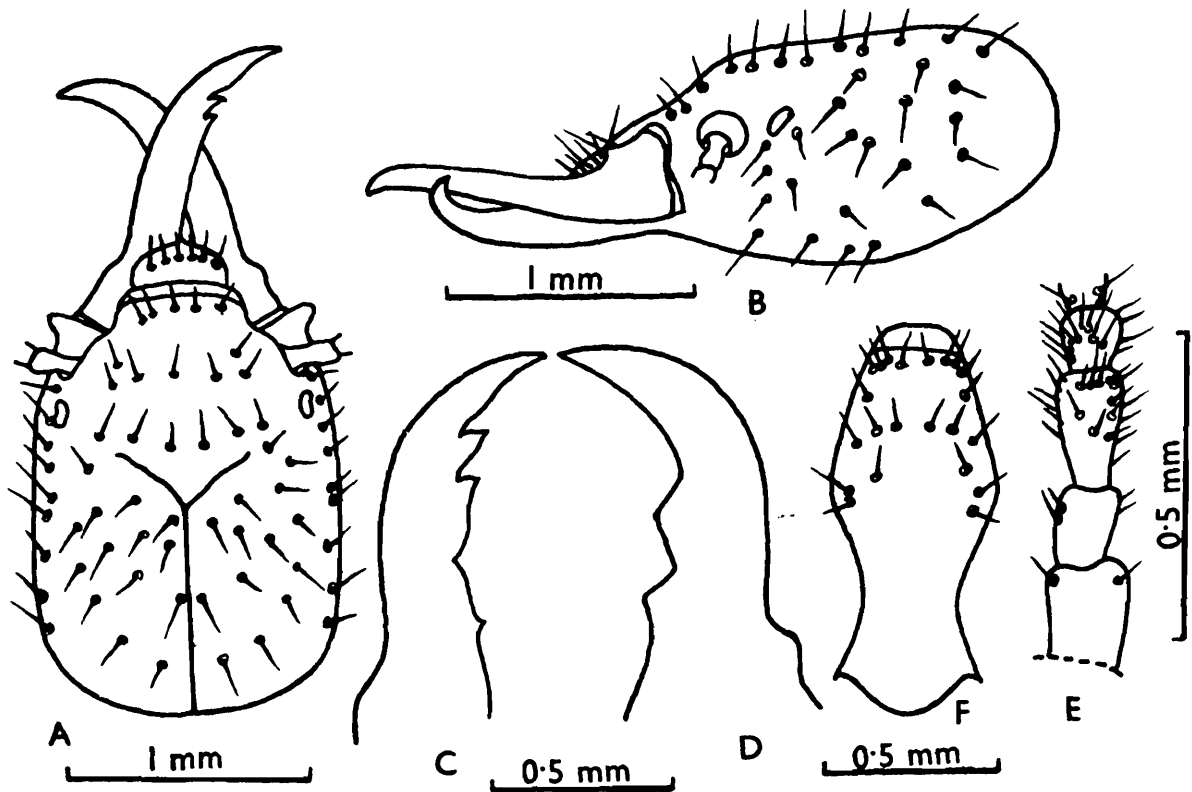

Fig. 197. *Procryptotermes hunsruiensis*. Soldier. (A) Head and pronotum, in dorsal view. (B) Head, in side view. (C) and (D) Left and right mandibles. (E) Antenna. (F) Postmentum (After Thakur, 1975a).

base. Right mandible with 2 large, subtriangular teeth one in middle and other in basal half. Postmentum club-shaped; broadest in anterior one-third followed by a narrow waist and widening out in basal region; with a few hairs in anterior half; anterior margin translucent, weakly convex; posterior margin convex in middle; (median length 0.93-1.08, maximum width 0.38-0.50, minimum width 0.15-0.25 mm). Pronotum flat, subreniform and with a median hyaline line; much broader than long, (width 1.05-1.28, length 0.60-0.80 mm); slightly narrower than head; sides convex; anterior margin concave; posterior margin substraight. Meso- and metanotum narrower than pronotum; sides rounded; posterior margin substraight. Legs short; femora thick, swollen and darker; tibia thin, apical tibial spurs 3:3:3; tarsi 4-jointed, Abdomen oblong, pilose; cerci 2-segmented, hairy, 0.10-0.13 mm long; styli short, one-jointed, 0.08 mm long.

**PSEUDOWORKER :** Head-capsule, antennae, labrum, clypeus, pronotum and legs creamy white to yellowish; body yellowish white to dirty white. Head moderately and body fairly pilose. Total length c 4.25-5.50 mm. Head-capsule subrounded, slightly broader than long (width 0.98-1.18,

length to base of mandibles 0.85-1.10 mm). Eyes white to pale brown, small, oval. Antennae 11-12 segmented, short; segment 4 shortest. Labrum broader than long, broadly tongue-shaped, anterior margin convex. Mandibles as in imago. Pronotum flat, subrectangular, much broader than long (width 0.78-1.00; length 0.50-0.63 mm); narrower than head; anterior margin weakly concave; sides curving down to a substraight or medially weakly emarginate, posterior margin. Legs and abdomen as in soldier.

*Distribution* : INDIA Karnataka Kalbet' (Hunsur, Siddapur).

### 53. *Procryptotermes valeriae* Bose

(Figs. 198, 199)

*Procryptotermes valeriae* Bose:

1979. Bose, *Bull. zool. Surv. India*, 2(1) : 53-59. Im, S, Pw. Holotype : S, in ZSI, Calcutta. Type-locality : India : Tamil Nadu : Tirunelveli-Nagercoil Road, between 11-12 mile stones from Nagercoil.

1984. Bose, *Occ. Pap. Rec. zool. Surv. India*, No. 49 : 56, 57, 60-61.

IMAGO (DEALATE) (Fig. 198) : Head-capsule, postclypeus, wing-scales and abdomen light chestnut brown; head darker in region of frons; ocelli and anteclypeus hyaline; labrum yellowish brown; antennae brown, apically pale yellowish. Head and body sparsely pilose. Total length without wings c 5.9 mm. Head-capsule subrectangular, oval, broadest at eye region (length to mandible-base equal to width with eyes, 1.0 mm); with a few hairs scattered all over; frons slightly sloping to postclypeus; Y-suture faintly visible. Eyes large, black, subcircular (maximum diameter 0.30, minimum diameter 0.24 mm); lying close to antennae. Ocelli suboval (maximum diameter 0.10 mm), translucent; situated very close to eyes (eye-ocellus distance 0.02 mm). Antennae 9+-segmented, segments 3 and 5 subequal, shortest. Anteclypeus apilose, trapezoidal, with straight anterior margin. Postclypeus flat, narrow, faintly demarcated from frons; with a few, short hairs on anterior corners. Labrum broadly tongue-shaped (length 0.23, width 0.40 mm); sides converging to substraight anterior margin; a few hairs present on anterior part. Pronotum shield-like, subrectangular (length 0.73, width 1.04 mm); broader than head-width with eyes; a few hairs present on margins and on body. Legs short, stout, sparsely pilose; apical tibial spurs 3:3:3; arolium between claws present. Abdomen oval, elongate; cerci 2-segmented, 0.05 mm long; styli one-segmented, 0.06 mm long.

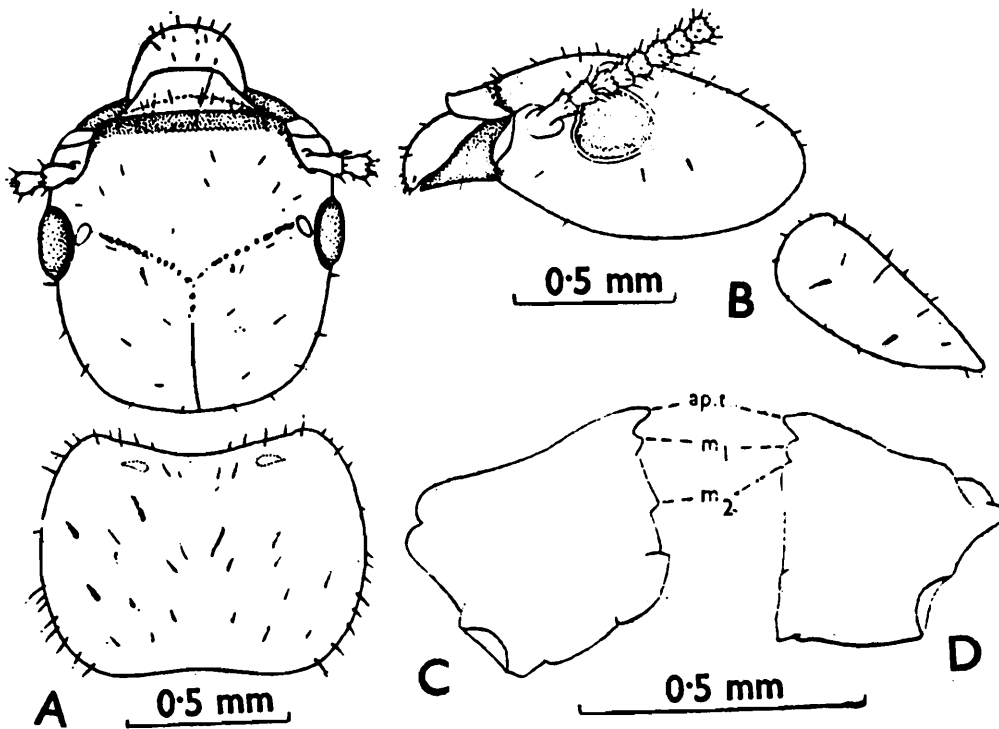

Fig. 198. *Procryptotermes valeriae*. Imago (A and B), Pseudoworker (C and D). (A) Head and pronotum, in dorsal view. (B) Same, in side view. (C) and (D) Left and right mandibles.

**SOLDIER** (Fig. 199) : Head-capsule anteriorly, postclypeus and mandibles dark chestnut brown; rest of head, antennae and thorax reddish brown; legs and abdomen brownish yellow. Head and body fairly pilose. Total length c 4.95-6.44 mm). Head-capsule subrectangular (length to base of mandibles 1.48-1.57, width 1.20-1.28 mm), frons medially depressed, sloping anteriorly at  $45^\circ$  angle; anterior sides of head prolonged into two bluntly pointed, horn-like projections just beyond antennae on either side; one near antero-lateral margin of postclypeus and other as prolongation of ventral genae. Eyes translucent, suboval (maximum diameter 0.15-0.18, minimum diameter 0.10-0.13 mm); from antennae lying at a distance of a little less than their minimum diameter. Ocelli absent. Antennae 11-13 segmented, segment 4 shortest. Anteclypeus strip-like, hyaline, apilose. Postclypeus trapezoidal, with a few hairs on anterior margin. Labrum short, broad, somewhat pointed in front and with a cluster of hairs on tip and few on body. Mandibles strong, large, curved inwards strongly at apex and robustly toothed. Left mandible with 4 marginal teeth. Right mandible with 2 marginals in middle. Postmentum short, club-shaped; widest a little

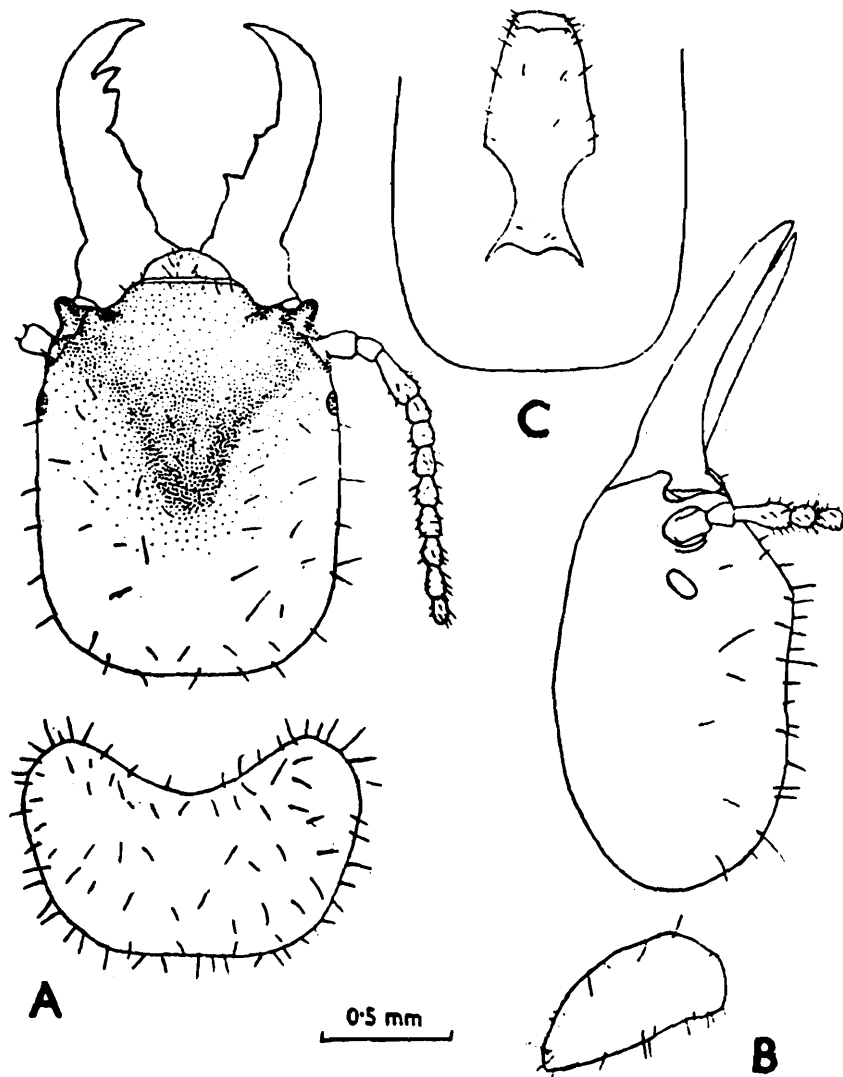

Fig. 199. *Procryptotermes valeriae*. Soldier. (A) Head and pronotum, in dorsal view. (B) Same, in side view. (C) Head, in ventral view, showing postmentum. (After Bose 1979).

below middle : at waist half as wide as maximum width (length 0.75-0.84, maximum width 0.38-0.40, width at waist 0.20 mm). Pronotum flat, semicircular, anterior margin deeply concave; sides rounded; posterior margin substraight; with long hairs on margins and on body; as wide as head (length 0.70-0.75, width 1.20-1.28 mm). Mesonotum narrower than and metanotum as broad as pronotum. Legs moderately long, pilose; apical tibial spurs 3:3:3. Abdomen oblong, pilose; cerci 2-segmented, 0.08-0.13 mm long; styli single-jointed, 0.05-0.08 mm long.

**PSEUDOWORKER** : Head-capsule and body pale creamy white; post-clypeus and labrum yellowish, mandibular teeth dark brown. Fairly pilose. Total length 4.8-6.6 mm. Head-capsule subcircular (length to mandible-base 1.05-1.10). Eyes rudimentary, oval, unpigmented, spot-like. Antennae

13-segmented, segments 4 and 5 subequal, shortest. Anteclypeus strip-like, hyaline, apilose. Postclypeus trapezoidal; with a row of long hairs at base and smaller ones on body. Labrum broad, tongue-shaped; with a large group of hairs below anterior margin and a few hairs medially. Mandibles as in genus. Pronotum broader than long (length 0.60-0.70, width 1.08-1.10 mm), semicircular, pilose; anterior margin concave; posterior margin substraight. Legs and abdomen as in soldier.

*Distribution* : INDIA : Between 11 and 12 milestones, Tirunelveli-Nagercoil Road, Nagercoil, Tamil Nadu.

**Genus 12. *Cryptotermes* Banks**  
(Synonym *Planocryptotermes* Light)

1. Genus *Cryptotermes* Banks :

1906. Banks, *Ent. News*, Philadelphia, 17(9) : 336.

1949. Snyder, *Smiths. misc. Colls.*, 112: 38, 359.

1961. Krishna, *Bull. Am. Mus. nat. Hist.*, 122(Art. 4), 314, 315, 316, 317, 379-382, 383, 384, 385, 388, 389. (Synonymy, Characters, etc.)

1969. Emerson, *Am. Mus. Novit.*, No. 2359 : 52.

1970. Krishna, In *Biology of Termites* Vol.2 (Eds. Krishna and Weesner) : 132, 133, 134.

1970. Roonwal, In *Biology of Termites* Vol. 2 (Eds. Krishna and Weesner) : 326-328.

1970. Chhotani, *Mem. zool. Surv. India*, 15(1): 1, 2-8, 71-72.

1972. Chhotani, In *Termite Problems in India*, (Ed. M. L. Roonwal): 23, 24.

1973. Chhotani and Bose, *Zool. Anz.*, 190(3/4) : 233, 234.

1975. Chhotani, *Zool. Anz.*, 194(1/2) : 115, 119, 120, 121, 122.

1975. Sen-Sarma et al., *Wood Destroying Termites of India* (Final Tech. Rept. PL 480 Progr.) : 7, 18, 19.

1980. Chhotani, *Tech. Monogr. Zool. Surv. India*, No. 4: 3, 24.

1983. Maiti, *Occ. Pap. Rec. zool. Surv. India*, No. 42: 16, 20, 40-44.

1983. Roonwal, *Proc. Indian natn. Sci. Acad.*, (B) 49(5) : 362, 378.

1984. He and Xia, *Contr. Shanghai Inst. Entom.*, 1982-83: 185-186 (Key to Chinese spp.).

1984. Bose, *Occ. Pap. Rec. zool. Surv. India*, No. 49: 16, 17, 18, 61-62.

1986. Grassé, *Termitologia*, Vol. 3: 511.

1987. Bacchus, *Trop. Pest. Bull.*, No. 7 : 2-5.

2. Genus *Planocryptotermes* Light :

1912. Light, *Philipp. J. Sci.*, 19(1): 41.

See Chhotani (1970) for detailed synonymies.

Type of genus : (i) *Cryptotermes cavifrons* Banks. (ii) *Of Planocryptotermes* : *P. nocens* Light (= *Cryptotermes dudleyi* Banks).

1. *Characters of Genus Cryptotermes*

*Imago* : Head-capsule subsquarish sides subparallel; epicranial suture present. Eyes small, round or broadly oval. Ocelli oval; generally touching the eyes, sometimes faintly separated. Antennae with 13-18 segments. Clypeus subtrapezoidal, flat, not clearly differentiated into ante- and postclypeus. Labrum broader than long. Mandibles, each with an apical and two marginal teeth; apical finger-like and long; 1st marginal short; anterior margin of 2nd marginal of left mandible about twice as long as posterior margins of 1st; posterior margin of 2nd marginal of right mandible one-and-a-half-times to twice length of molar plate. Pronotum weakly narrower to somewhat wider than head. Legs with apical tibial spurs 3:3:3; tarsi 4-jointed; arolium present in majority of species. Wings with papillae, pimples and tubercles, hairy on margins and on scales; all veins arising independently from scale in both wings except media from radial sector in hindwing; costa, subcosta, radius and radial sector thick, chitinised, running close to anterior margin; media and cubitus weak; subcosta in forewing short and fusing with costa just outside scale; absent in hindwing; radius fusing with costa at about one-third to middle of wing-membrane in forewing and at about middle or a little beyond middle in hindwing; radial sector with 3-10 branches to costa; media curving up and meeting radial sector beyond middle of wing membrane; cubitus with 10-15 branches. Abdomen elongate; cerci 2-jointed.

*Soldier* : Head-capsule generally dark brown, almost black in front; short, thick and phragmotic; rough in region of frons, vertex and sides in some species; frontal areas sharply truncated, sometimes overhanging; frontal ridge between frons and vertex present, thick; generally with 2 horn-like projections antero-laterally on either side, dorsal-one being projection from frons near lateral hind corners of postclypeus and ventral-one being prolongation of ventral genae, sometimes either of them or both absent;

frons generally incurved; vertex behind ridge depressed medially. Eyes unpigmented, small, oval. Ocelli absent. Antennae with 11-15 segments. Clypeus subtrapezoidal, only sometimes clearly demarcated from frons. Labrum subtriangular or tongue-shaped. Mandibles generally short, thick and humped basally at outer margin, sometimes somewhat longish; either without dentition or weakly dentate. Postmentum broad posteriorly. Pronotum as wide as or weakly narrower than head; anterior margin concave, wavy or serrate, emarginate medially. Legs short, apical tibial spurs 3:3:3; tarsi 4-jointed. Abdomen elongate, creamish white; cerci 2-jointed.

**PSEUDOWORKER :** Head-capsule subcircular; broader than its length to base of mandibles. Eyes rudimentary. Ocelli absent. Antennae 10 to 15 segmented. Mandibles as in imago. Pronotum subrectangular, weakly to deeply concave at anterior margin. Legs and abdomen as in soldier.

**Affinities :** The genera *Procryptotermes* and *Cryptotermes* both have the media of imago wings curving up to meet the radial sector, and identical imago-worker mandibles. They fall in a single group which seems to have branched off separately from the second line of divergence from the ancestral Kalotermitid as suggested by Krishna (1961). The imago of both these genera are generally similar but the soldier of *Cryptotermes*, with highly phragmotic head and shorter 3rd antennal segment, shows its higher evolutionary status.

## 2. *Distribution and Composition of Cryptotermes*

**Distribution :** The species of genus *Cryptotermes* are generally restricted to the coastal regions except for a few records from the interiors. The general range of its distribution is approximately 33° N. to 35° S. latitudes in the Australian, Papuan, Oriental, Ethiopian, Malagasy, Nearctic and Neotropical regions. Due to their habit of infesting wooden structures, furnitures and wooden articles they are easily transportable, as such a number of species are cosmopolitan in distribution.

**Composition :** Thirtysix species of *Cryptotermes* are known from the world of which 12 occur in the Oriental region. Only six species are so far recorded from the Indian subregion. Since the species of this genus have a very wide distribution and there is every likelihood of getting the other Oriental species within Indian subregion a list of all the oriental species with

their distribution and keys are given below

- \*1. *Cryptotermes bengalensis* Snyder. India, Sri Lanka, Bangladesh.
  - \*2. *Cryptotermes brevis* (Walker). Hongkong, Africa, S. America, Central America, southern U.S.A., Australia, Islands in Pacific and Atlantic.
  - 3. *Cryptotermes cynocephalus* Light. Philippines, Indonesia, Malaysia, New Britain Isl. (Pacific), Australia.
  - 4. *C. æclivis* Tsai & Chen. Southern China.
  - \*5. *C. domesticus* Haviland. India, China, Sri Lanka, Singapore, Indonesia, Thailand, Vietnam, Japan, Australia, Pacific islands, Panama (Central America).
  - \*6. *C. dudleyi* Banks. India, Sri Lanka, Bangladesh, Indonesia, Malaysia, Philippines, Africa, Australia, Central America, South America (Colombia).
  - \*7. *C. karachiensis* Akhtar. Pakistan.
  - \*8. *C. perforans* Kemner. Sri Lanka.
  - \*9. *C. roonwali* Chhotani. India.
  - 10. *C. sakauensis* Thapa. Sabah (Malaysia).
  - 11. *C. sumatrensis* Kemner. Indonesia (Sumatra).
  - 12. *C. thailandis* Ahmad. Thailand.
- \*Occur in Indian Region

### 3. Keys to Oriental Species of *Cryptotermes*

#### IMAGOES

The imago of 10 out of 12 Oriental species are known. The specimens of *C. declivis* Tsai & Chen, *C. karachiensis* Akhtar and *C. thailandis* Ahmad were not available but they have been included in key on the basis of characters from literature.

1(4) Smaller species : Head-width with eyes 0.77-0.85, head length to tip of labrum 1.0-1.07, to lateral base of mandibles 0.80-0.83 mm. Distance between eye and lower margin of head small (0.11-0.13 mm)

2(3) Darker and slightly larger species; head-capsule brown to dark reddish brown. Eyes larger (Maximum diameter of eyes 0.29-0.31 mm)

*cynocephalus*

- 3(2) Paler and slightly smaller species; head-capsule brownish yellow. Eyes smaller (Maximum diameter of eyes 0.27 mm)..... *perforans*
- 4(1) Larger species: Head-width 1.00-1.17, head-length to tip of labrum 1.19-1.40, to lateral base of mandibles 0.87-1.10 mm. Distance between eye and lower margin of head large (0.15-0.20 mm)
- 5(6) Head wide (width with eyes 1.05-1.17 mm)..... *brevis*
- 6(5) Head generally narrow (width with eyes 0.90-1.10 mm)
- 7(10) Eyes large, maximum diameter 0.33-0.37 mm.
- 8(9) Eyes oval, narrowed posteriorly ..... *sumatrensis*
- 9(8) Eyes oval, not narrowed posteriorly..... *karachiensis*
- 10(7) Eyes generally small, maximum diameter 0.27-0.33 mm
- 11(12) Head larger and ocelli smaller (Head-width with eyes 1.09-1.13 mm; ocellus-length 0.08-0.09 mm)..... *declivis*
- 12(11) Head smaller and ocelli larger (head-width with eyes 0.90-1.10 mm; ocellus-length 0.09-0.13 mm).
- 13(16) Eyes smaller (maximum diameter 0.27-0.30, rarely above 0.30 mm)
- 14(15) Sides of head-capsule incurved in region of eyes..... *domesticus*
- 15(14) Sides of head-capsule substraight in region of eyes..... *thailandis*
- 16(13) Eyes larger (maximum diameter 0.30-0.33 mm)
- 17(18) Ocelli farther from antennae (minimum ocellus-antennal distance 0.17-0.19 mm)..... *dudleyi*
- 18(17) Ocelli nearer antennae (minimum ocellus antennal distance 0.13-0.17, rarely 0.17 mm)..... *bengalensis*

### SOLDIERS

- 1(2) Head-capsule with only ventral tubercle (i.e. horn-like projection of ventral gena) prominent, the dorsal-one very weak. Frontal ridge of head strongly projecting in front medially, reaching beyond base of mandibles (index: Maximum length of head upto frontal ridge/Length of head to base of mandibles 1.10-1.25) and making an angle of less than 90° with mandibles..... *domesticus*
- 2(1) Head-capsule with both tubercles (i.e., horn-like projection of ventral gena and the projection from frons near the lateral base of post-clypeus) prominent, frontal ridge of head not projecting in front medially, laterally sometimes weakly projecting in front (index: Maximum length of head upto frontal ridge/Length of head to base of mandibles 0.85-1.05) and making an angle of generally more than 90° with mandibles.

- 3(4) Head-capsule, frontal ridge and vertex strongly wrinkled and roughened ..... *brevis*
- 4(3) Head-capsule and frontal ridge smooth, vertex sometimes slightly roughened
- 5(6) Larger species (head-length to lateral base of mandibles 1.60-1.80; maximum width of head 1.27-1.43 mm). Mandibles longish and with prominent dentition; frontal ridge weak and strongly pushed back medially..... *dudleyi*
- 6(5) Smaller species (head-length to lateral base of mandibles 0.83-1.47; maximum width of head 0.90-1.35 mm. Mandibles short, thick and with weak dentition; frontal ridge prominent and not strongly pushed back medially
- 7(8) Frontal ridge with a deep median cleft..... *sumatrensis*
- 8(7) Frontal ridge with or without median notch but without a cleft
- 9(18) Ventral tubercle (i.e. horn-like projection of ventral genae) large, longer than dorsal-one and visible in dorsal view of head. Larger species : Head-length to base of mandibles 1.13-1.47 mm; head-width 1.10-1.35 mm
- 10(11) Mandibles strongly humped basally at outer margin; frontal ridge prominently swollen, deeply notched and strongly pushed back medially ..... *karachiensis*
- 11(10) Mandibles weakly humped; frontal ridge less swollen, weakly notched and less so pushed back medially
- 12(17) Ventral tubercle larger and prominently projecting in front of dorsal-one when viewed dorsally; frontal ridge lying much behind mandibular base
- 13(16) Pronotum somewhat rectangular
- 14(15) Head and pronotum wider; frontal ridge less so incurved and notched medially; eye narrower..... *thailandis*
- 15(14) Head and pronotum narrower; frontal ridge more strongly incurved and with a V-shaped notch medially; eye wider..... *sakauensis*
- 16(13) Pronotum somewhat subcircular..... *declivis*
- 17(12) Ventral tubercle smaller and slightly projecting in front of dorsal-one when viewed dorsally; frontal ridge lying almost at level of mandibular base..... *bengalensis*
- 18(9) Ventral tubercle short, shorter than dorsal-one and not visible dorsally. Smaller species : Head-length to base of mandibles 0.83-1.10, head-width 0.75-1.03 mm
- 19(20) Frontal ridge gradually raised in front, not ribbon-like; frons dec-

- ply concave; vertex comparatively rough. Head smaller (length to base of mandibles 0.83, maximum width 0.75-0.90 mm)..... *cynocephalus*
- 20(19) Frontal ridge ribbon-like; frons weakly concave; vertex comparatively smooth. Head larger (length to base of mandibles 0.97-1.17, maximum width 0.90-1.03 mm)
- 21(22) Frontal ridge thick and prominently raised; mandibles strongly humped basally on outer margins; head-capsule thick, height of head more as compared to length and width (index Height/Length to base of mandibles 0.78-0.82; Height/maximum width 0.82-0.88). Head smaller (length to base of mandibles 0.97-1.03, maximum width 0.90-1.00 mm)..... *perforans*
- 22(21) Frontal ridge thin, flat and weakly raised; mandibles weakly humped basally on outer margins; head-capsule thin, height of head less as compared to length and width (index Height/Length to base of mandibles 0.71-0.73; Height/Maximum width 0.78-0.80). Head larger (length to base of mandibles 1.10-1.17, maximum width 1.00-1.03 mm)..... *roonwali*

#### 54. *Cryptotermes bengalensis* Snyder (Figs. 200-202)

##### 1. *Kalotermes (Cryptotermes) bengalensis* Snyder :

1934. Snyder, *Indian For. Rec.*, 20(11): 4-6. Im, S. Syntypes : In BM, London and FRI, Dehra Dun (India). Type-locality : Sundarbans (West Bengal, India).

##### 2. *Cryptotermes havilandi* (Sjöstedt) (Part) :

1955. Moszkowski, *Mem. Inst. Sci. Madagascar*, (E) 6: 15-29 (Indian records only).

1970. Chhotani, *Mem. zool. Surv. India*, 15(1): 42-54. (Records from Indian region only. Also see for detailed synonymy for *bengalensis* Snyder).

1970. Roonwal, In *Biology of Termites* Vol. 2 (Ed. Krishna and Weesner) : 328.

1975. Chhotani, *Zool. Anz.*, 194: 119.

1975. Akhtar, *Bull. Dept. Zool. Univ. Panjab* (N.S.), Art 7 : 28, 31-35 (see for other references also).

1979. Roonwal, *Termite Life and Termite Control in Tropical South Asia* : 51, 78, 116, 121.

1980. Chhotani, *Tech. Monogr. Zool. Surv. India*, No. 4: 5, 24-25.

1983. Maiti, *Occ. Pap. Rec. zool. Surv. India*, No. 42: 42-44.

1984. He and Xia, *Contr. Shanghai Inst. Entomol.*, 1982-83 : 185, 186.

1984. Bose, *Occ. Pap. Rec. zool. Surv. India*, No. 49 : 62, 66-69.

##### 3. *Cryptotermes bengalensis* Snyder :

1975. Sen-Sarma et al., *Wood destroying Termites of India. (Final Tech. Rep. PL-480 Proj.)*: 10, 19-21.

1979. Sen-Sarma and Thakur, *Indian For. Rec. (N.S.) Ent.*, 13(1): 9-10.

1982. Thakur and Rathore, *J. Bombay nat. Hist. Soc.*, 79: 699-700.

1987. Bacchus, *Trop. Pest Bull.*, No. 7: 1, 2, 3, 5, 8, 9, 10, 25, 30, 38-40, 57, 77, 78, 85, 86.

*Cryptotermes angulatus/brachygnathus/ceylonicus* (MS. names) : See Chhotani (1970, p. 42) for details.

**IMAGO** (Figs. 200, 201) Head-capsule pale brownish, paler anteriorly; labrum, antennae and legs yellowish; abdomen paler than head. Head and body fairly densely hairy. Total body-length with wings 8.0-10.1, without wings 4.7-6.4 mm. Head-capsule subrectangular; with eyes slightly broader than length to base of mandibles (length to base of mandibles 0.87-1.03, width with eyes 0.90-1.07 mm); epicranial suture faint. Eyes oval, medium sized (maximum diameter 0.30-0.34 mm); from lateral margin situated at

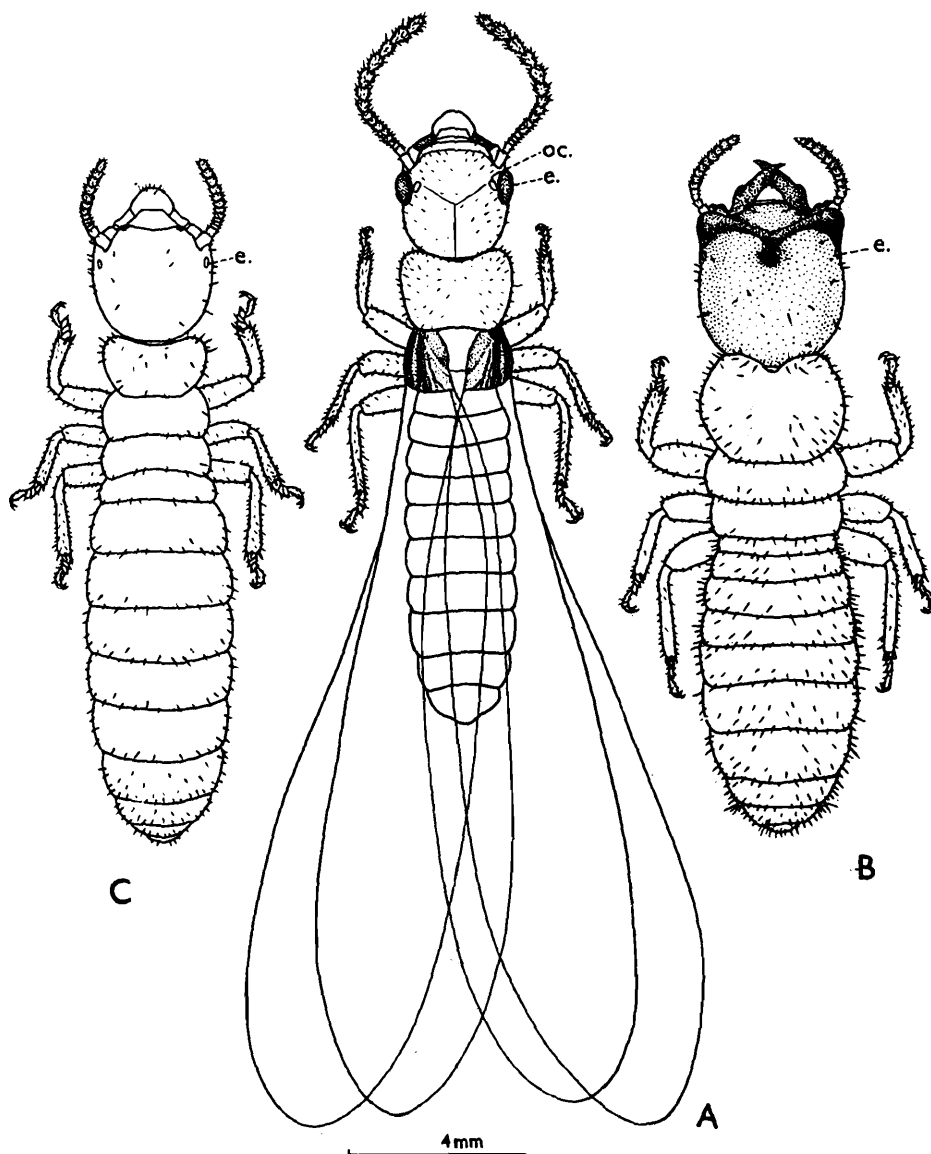

Fig. 200. *Cryptotermes bengalensis*. (A) Imago. (B) Soldier. (C) Pseudoworker. e., eye; oc., ocellus. (After Chhotani 1970).

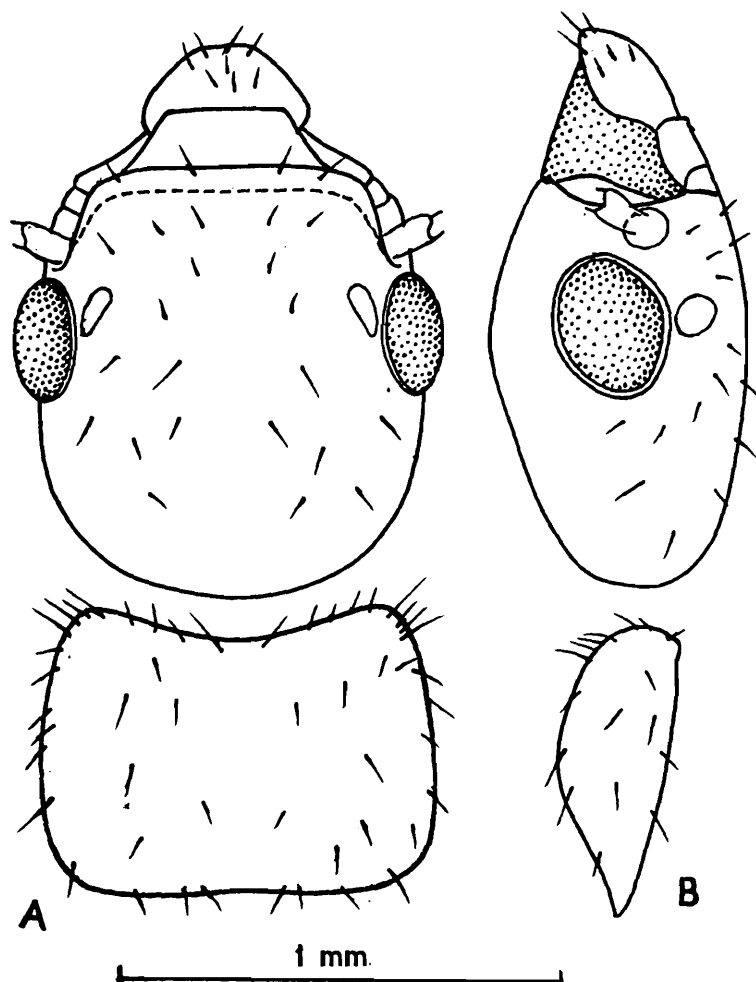

Fig. 201. *Cryptotermes bengalensis*. Imago. (A) Head and pronotum, in dorsal view. (B) Same, side view.

about half their diameter. Ocelli small, oval (0.09-0.13 mm long and 0.05-0.07 mm wide); either touching the eyes or separated by a thin line. Antennae with 13-17 (generally 15-17) segments; segment 2 a little longer than half of 1; 3 either subequal to or slightly longer than 4; 4 generally shortest. Anteclypeus hyaline, subtrapezoidal, apilose; postclypeus pilose, anteriorly outcurved weakly. Labrum broadly tongue-shaped, hairy near tip and on body; 0.23-0.40 mm long and 0.33-0.40 mm wide. Mandibles typically *Cryptotermes*-type. Pronotum generally narrower than and sometimes as wide as head with eyes (length 0.60-0.70, width 0.80-1.10 mm); anterior margin incurved appreciably; sides depressed and substraight; posterior margin incurved medially. Legs short, pilose, forelegs shortest, hindlegs longest; apical tibial spurs 3:3:3; tarsi 4-jointed; arolium present.

Wings hyaline, with a weak brownish tinge. Forewing : Radius fusing with costa at about one-fourth of wing; radial sector with 5-7 branches to costa; media curving up to meet radial sector at about distal third between 3rd to 5th branches of latter; cubitus with 10-14 branches to posterior margin. Hindwing Radius as in forewing; radial sector with 3-6 branches to costa; media meeting radial sector at about two-thirds of wing between 2nd and 3rd branches of latter; cubitus with 13-15 branches. Abdomen elongate, densely hairy; cerci 2-jointed; styli (in male) short, single-jointed.

**SOLDIER** (Figs. 200, 202) Head-capsule reddish to dark brown, blackish anteriorly; antennae, labrum, thorax and body pale yellowish to pale brownish. Head sparsely and body moderately hairy. Total length 3.8-6.2 mm. Head-capsule short, thick, subsquarish to subrectangular (length to base of mandibles 1.13-1.47, width 1.08-1.35 mm); frons sharply inclining in front and incurved; frontal ridge variable, prominent and overhanging frons (length of base to frontal ridge 1.10-1.33 mm); both tubercles large and prominent; vertex with a shallow depression medially just behind frontal ridge. Eyes present as small, oval, pale spots. Antennae with 11-15 segments; segment 2 about half of 1; 3 either shortest or subequal to 2, sometimes subdivided. Anteclypeus thin, narrow, apilose, strip-like; postclypeus subtrapezoidal, weakly pilose. Labrum subtriangular, broad at base (length 0.10-0.19, width 0.20-0.27 mm); either apilose or with a pair of hairs at tip. Mandibles short, stout, triangular and prominently humped a little above outer condyle (length 0.44-0.60 mm); each mandible with 2 weak to prominent marginal teeth; 2nd marginal of left mandible sometimes absent. Postmentum short, broader posteriorly, anterior margin substraight to weakly incurved. Pronotum weakly narrower to somewhat broader than head (length 0.70-0.90, width 1.00-1.30 mm); sides rounded; anterior margin deeply incurved; posterior margin substraight to slightly curved outwards. Meso- and metanotum narrower than pronotum. Legs short and hairy, femora swollen; apical tibial spurs 3:3:3; tarsi 4-jointed. Abdomen oblong, hairy; cerci 2-jointed; styli single-jointed.

**PSEUDOWORKER** (Fig. 200) : Head and body pale yellowish, sparsely hairy. Total length 4.4-6.0 mm. Head-capsule subcircular, wider than its length to base of mandibles (length to base of mandibles 1.00-1.10, width 1.10-1.20 mm). Eye-spots present. Antennae with 12-14 segments.

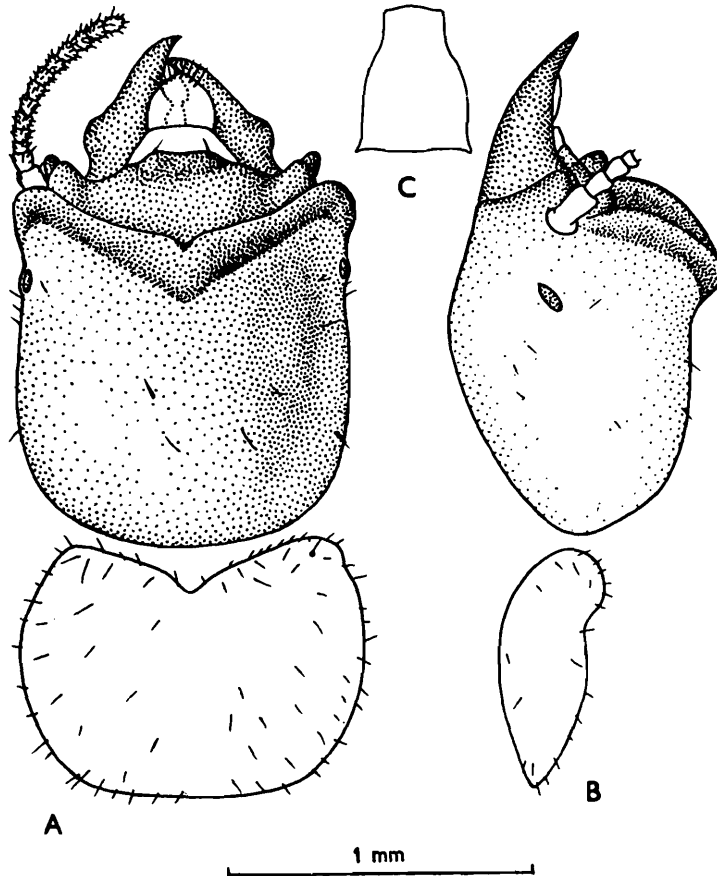

Fig. 202. *Cryptotermes bengalensis*. Soldier. (A) Head and pronotum, in dorsal view. (B) Same, side view. (C) Postmentum.

Clypeus not clearly differentiated into ante- and postclypeus. Labrum and mandibles as in imago. Pronotum flat, narrower than head-capsule (length 0.53-0.66, width 0.97-1.00 mm). Legs and abdomen as in soldier.

**Distribution** : From the Indian subregion it is reported from India (Assam, Tripura, West Bengal, Orissa, Madhya Pradesh, Gujarat and Karnataka states and Andaman and Nicobar Islands) also Sri Lanka and Bangladesh.

**Biology** : This drywood termite is reported from wild and semi-wild habitat and also from woodworks in buildings. It's nests are in the form of narrow, longitudinal galleries and flat chambers which may be partially filled with loose, faecal pellets. The swarming of the species is during May to June.

**55. *Cryptotermes domesticus* (Haviland)**  
(Figs. 203-206)

[Synonyms: *Calotermes (Cryptotermes) formosae* Holmgren, *Calotermes (Cryptotermes) kotoensis* Oshima, *Calotermes (Cryptotermes) ogasawarensis* Oshima, *Calotermes (Cryptotermes) dentatus* Oshima, *Cryptotermes campbelli* Light, *Cryptotermes hermsi* Kirby, *Calotermes (Cryptotermes) buxtoni* Hill, *Calotermes (Cryptotermes) gulosus* Hill, *Calotermes (Cryptotermes) repentinus* Hill, *Cryptotermes lignarius* Kemner *Ms name*, *Cryptotermes tectus* Kemner *Ms name*.]

1. *Calotermes domesticus* Haviland :

1898. Haviland, *J. Linn. Soc. Lond.*, 26(169): 374; pl. 23 (figs. 3-4, soldier, 5-6 (Imago).  
Im, S. Lectotype : (selected Chhotani, 1970), in University Museum of Zoology,  
Cambridge (England). Type-locality : Sarawak.

2. *Cryptotermes domesticus* (Haviland) :

1949. Snyder, *Smiths. misc. Colls.*, 112: 40-41.

1961. Krishna, *Bull. Am. Mus. nat. Hist.*, 122(Art. 4): 382.

1970. Chhotani, *Mem. zool. Surv. India*, 15(1): 1, 3, 4, 5, 8, 24-34, 71, 74, 75.  
(Detailed Synonymy, distribution, etc.)

1970. Roonwal, In *Biology of Termites* (ed. Krishna and Weesner) Vol. 2. : 327.

1975. Chhotani, *Zool. Anz.*, 194 : 119, 123.

1979. Roonwal, *Termite Life and Termite Control in Tropical South Asia*, : 51, 52, 62,  
78, 116, 119-123.

1980. Chhotani, *Tech. Monogr. Zool. Surv. India*, No. 4: 4, 24, 25.

1982. Gay and Watson, *Austr. J. Zool.*, (Suppl. ser.) No. 58: 12-15, 41, 42, 51.

1984. He and Xia, *Contr. Shanghai Inst. Entomol.*, 1982-83 : 185-186.

1984. Bose, *Occ. Pap. Rec. zool. Surv. India*, No. 49 : 62, 63-64.

1987. Bacchus, *Trop. Pest Bull.*, No. 7: 2, 3, 5, 8, 9, 10, 14, 32, 35, 42, 50-52, 60, 70,  
86, 87.

3. *Calotermes (Cryptotermes) formosae* Holmgren :

1912. Holmgren, *Annot. Zool. Jap.*, 8: 119-120. Im, S. Syntypes in Nat. Hist.  
Museum, Vienna. Type-locality : Botel Tobago (Taiwan).

4. *Calotermes (Cryptotermes) kotoensis* Oshima :

1912. Oshima, *3rd Official Report Termites* : 56, pl. 2, figs. 3, 4, 17, 18. Syntypes  
in Institute of Science, Govt. Taiwan. Type-locality. Botel Tobago (Taiwan).

5. *Calotermes (Cryptotermes) ogasawarensis* Oshima :

1913. Oshima, *Philipp. J. Sci.*, (D) 8(4): 274-276. Imago and Soldier. Repository of types not known. *Type-locality* : Ogosawarajima Isl. (Japan).

6. *Calotermes (Cryptotermes) dentatus* Oshima :

1914. Oshima, *Zool. Anz.*, 44(7) : 289-291. Imago and Soldier. Repository of types not known. *Type-locality* : Touhoku (Formosa).

7. *Cryptotermes campbelli* Light :

1924. Light, *China J. Sci. Arts*, 2(1-4) : 57-60, Queen and S. Syntypes : In AMNH, New York. *Type-locality* : Kachek, Hainan Isl. (China).

8. *Cryptotermes hermsi* Kirby :

1925. Kirby, *Calif. Univ. Publ. (Zool.)*, 26: 437-441. Im, S. Holotype ♂ imago, in U.S. National Museum, Washington. *Type-locality*: Fanning Island (N. Pacific).

9. *Calotermes (Cryptotermes) buxtoni* Hill :

1926. Hill, *Entomologist*, London, 59(762) : 298. Im, and S. Syntypes in BM and AMNH, New York. *Type locality* : Apia (Upolu Isl., Samoa Isls., S. Pacific).

10. *Calotermes (Cryptotermes) gulosus* Hill :

1927. Hill, *Mem. natn. Mus. Melb.*, No., 7 : 11-13. Im S. Holotype : S, in AMNH, New York. *Type-locality* : 30 miles S.E. of Port Moresby (New Guinea).

11. *Calotermes (Cryptotermes) repentinus* Hill :

1927. Hill, *Mem. natn. Mus. Melb.*, No. 7 : 13-14. Imago. Holotype : Imago, in American Museum of Natural History, New York. *Type-locality* : Rabaul (New Britain, S. Pacific).

12. *Cryptotermes lignarius* Kemner (Ms name) :

1941. Pinto, *Indian J. Ent.*, 3(1) : 85.

1970. Chhotani, *Mem. zool. Surv. India*, 15(1) : 26.

13. *Cryptotermes tectus* Kemner (Ms name) :

1941. Pinto, *Indian J. Ent.*, 3(1) : 85.

1970. Chhotani, *Mem. zool. Surv. India*, 15(1) : 26.

For complete synonymy Chhotani (1970).

**IMAGO (Figs. 203, 204) :** Head pale yellow to pale brown; labrum, antennae, legs and body yellowish, paler than head. Head and body moderately pilose. Total length with wings 7.50-10.0, without wings 4.50-6.90 mm. Head subrectangular (length to base of mandibles 0.90-1.00, width with eyes 0.90-1.00 mm); with parallel sides and rounded posterior

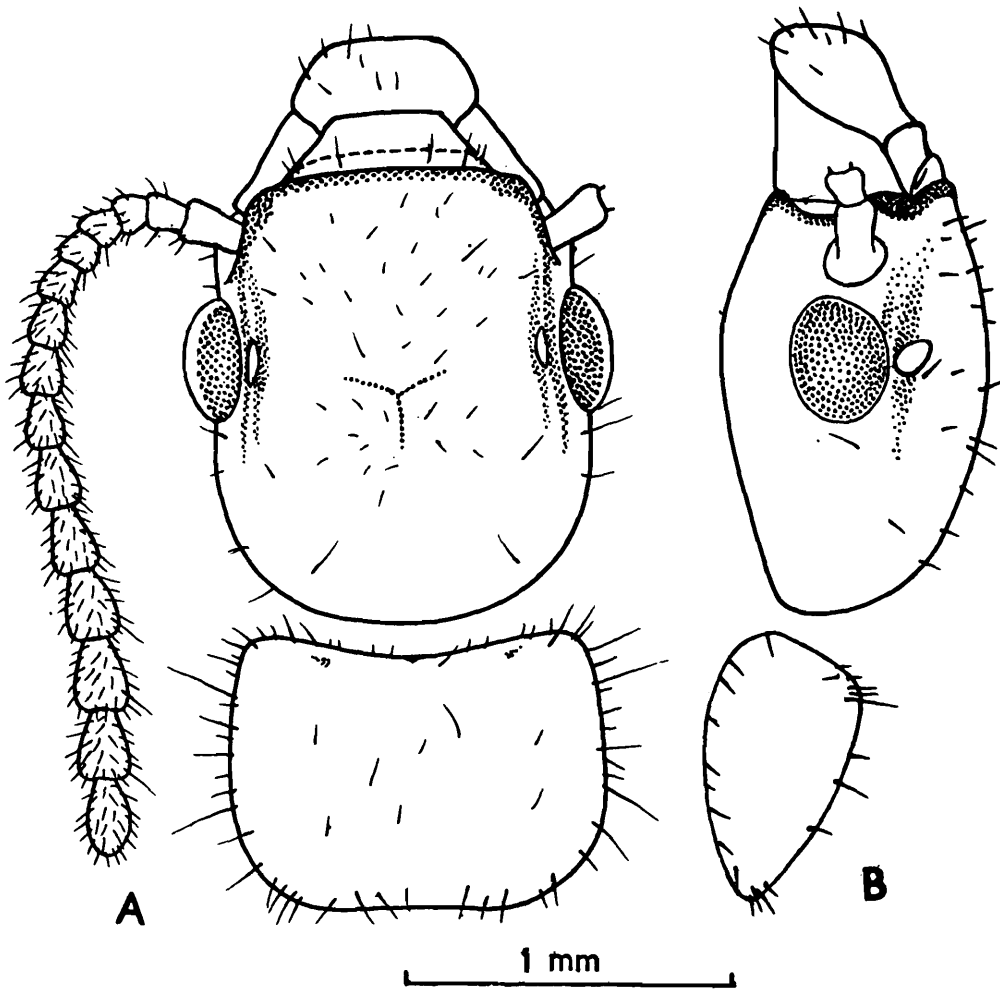

Fig. 203. *Cryptotermes domesticus*. Imago. (Lectomorphotype). (A) Head and pronotum, dorsal view. (B) Same, side view (Redrawn from Chhotani 1970).

margin; Y-suture faint. Eyes black, oval 0.23-0.37 mm in diameter. Ocelli small, oval, 0.09-0.13 mm long, transparent; either touching eyes or separated by a thin line. Antennae with 14-17 segments; segment 2 about half of 1; 3 pyriform subequal to or slightly shorter than 2; 4 shortest. Anteclypeus hardly differentiated, faintly incurved anteriorly; post-clypeus weakly pilose. Labrum broader than long; rounded anteriorly and pilose near tip and on body. Mandibles as in genus. Pronotum flat, subreniform, length 0.57-0.77, width 0.73-1.10 mm; slightly narrower to somewhat broader than head with eyes; sides substraight to weakly convex; anterior margin weakly incurved; posterior margin substraight to faintly rounded, sometimes somewhat incurved medially. Meso- and metanotum weakly incurved at posterior margins. Forelegs shortest, hindlegs longest;

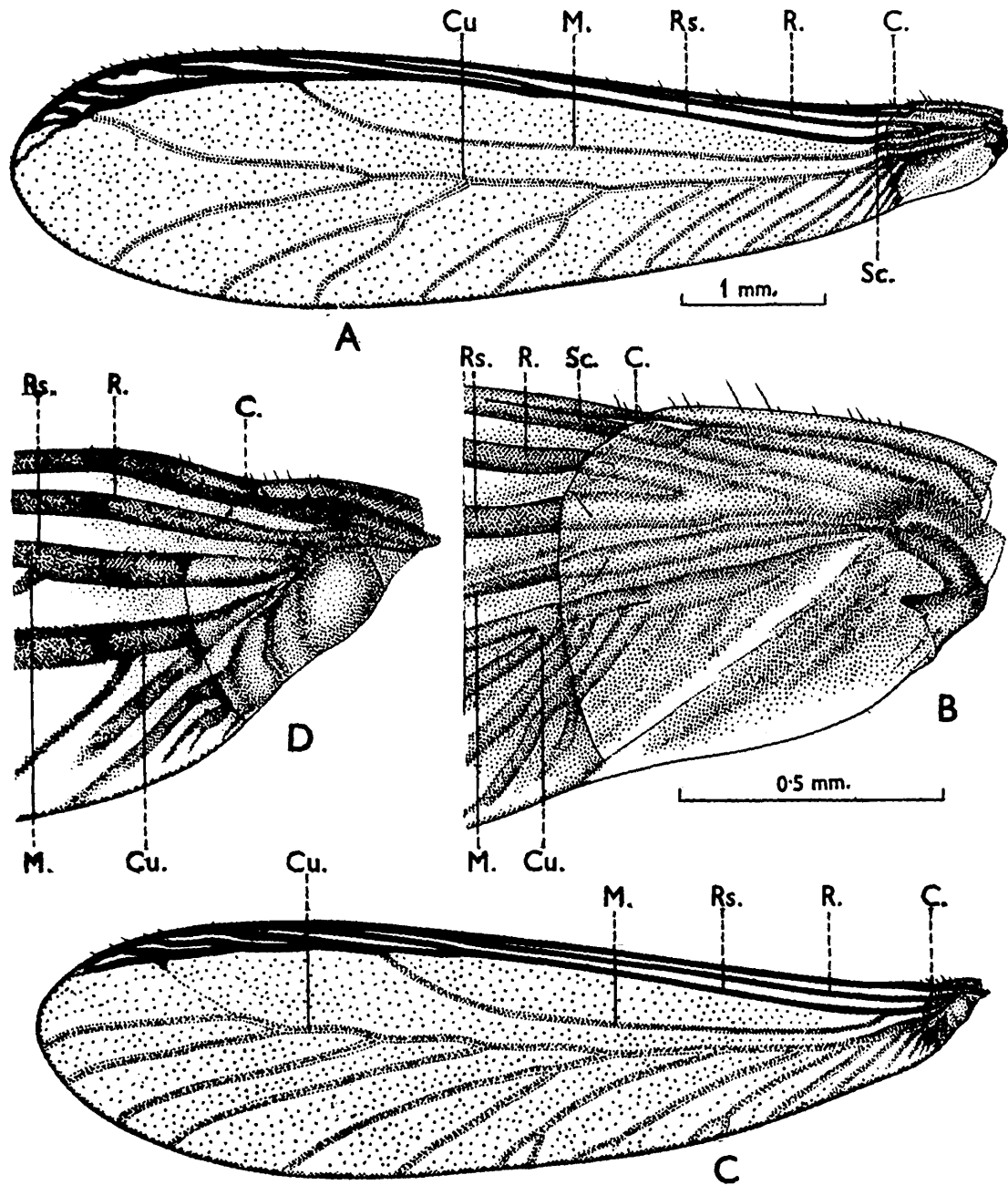

Fig. 204. *Cryptotermes domesticus*. Wings. (A) Forewing, (B) Same, proximal part enlarged. (C) Hindwing. (D) Same, proximal part enlarged.

C., costa; Cu., cubitus; M., media; R., radius; Rs., radial sector; Sc., subcosta. (After Chhotani 1970)

apical tibial spurs 3:3:3; tarsi 4-jointed; arolium present. Wings transparent, pale yellow; venation, etc. as in genus except as follows: Forewing : Radius short, meeting costa at about one-fourth to one-third the length of wing-membrane; radial sector with 6-10 branches to costal border, first branching at about one-third to middle of wing membrane; media curving up to meet radial sector at about middle to distal one-third of wing; cubitus with 11-13 branches. Length with scale c 6.40-7.20 mm. Hindwing : Radius meeting costa at about middle of wing; radial sector with 4-6 branches to costa; media as in forewing, except arising from radial sector; cubitus with 10-11 branches to posterior margin. Length with scale 6.0-6.80 mm. Abdomen elongate, oval, hairy; cerci 2-jointed; styli (in males) unsegmented.

**SOLDIER** (Figs. 205, 206): Head-capsule black, slightly paler posteriorly; antennae, labrum, legs and body yellowish to pale brown; pronotum darker near anterior margin; mandibles blackish. Head and body sparsely hairy. Total length 4.00-6.00 mm. Head-capsule subrectangular, thick, truncated in front, length to base of mandibles 1.20-1.30, width 1.13-1.30 mm; with a prominent, knob-like tubercle, projecting in front from ventral genae on either side; a weak swelling in place of dorsal tubercle present on frons a little above antennae; frontal ridge prominent, weakly to strongly notched medially and strongly projecting in front, reaching up to base of mandibles to middle of mandibles (head-length upto frontal ridge 1.27-1.53 mm); frons truncated, inclining at right angle or making a smaller angle with mandibles when projecting in front. Eye spots small, suboval, one on either side. Antennae with 11-14 segments; segment 2 a little longer than half of 1, 3 either shortest or a little longer or subequal to 4. Clypeus separated from frons by a thin groove; divided into anteclypeus and postclypeus; anteclypeus thin, narrow, strip-like; postclypeus narrow, subrectangular. Labrum subtriangular to broadly tongue-shaped, broader than long; with a pair of bristle-like hairs at anterior end. Mandibles short, thick and triangular, length 0.50-0.60 mm; sharply pointed at tips and with a prominent hump at outer margin just above condyle; a pair of weak, minute teeth present on inner margin of each mandible, sometimes absent. Postmentum short, squarish, somewhat broader posteriorly; anterior margin faintly incurved. Pronotum flat, slightly raised near anterior margin; generally narrower but sometimes as wide as head (length 0.53-0.87, width

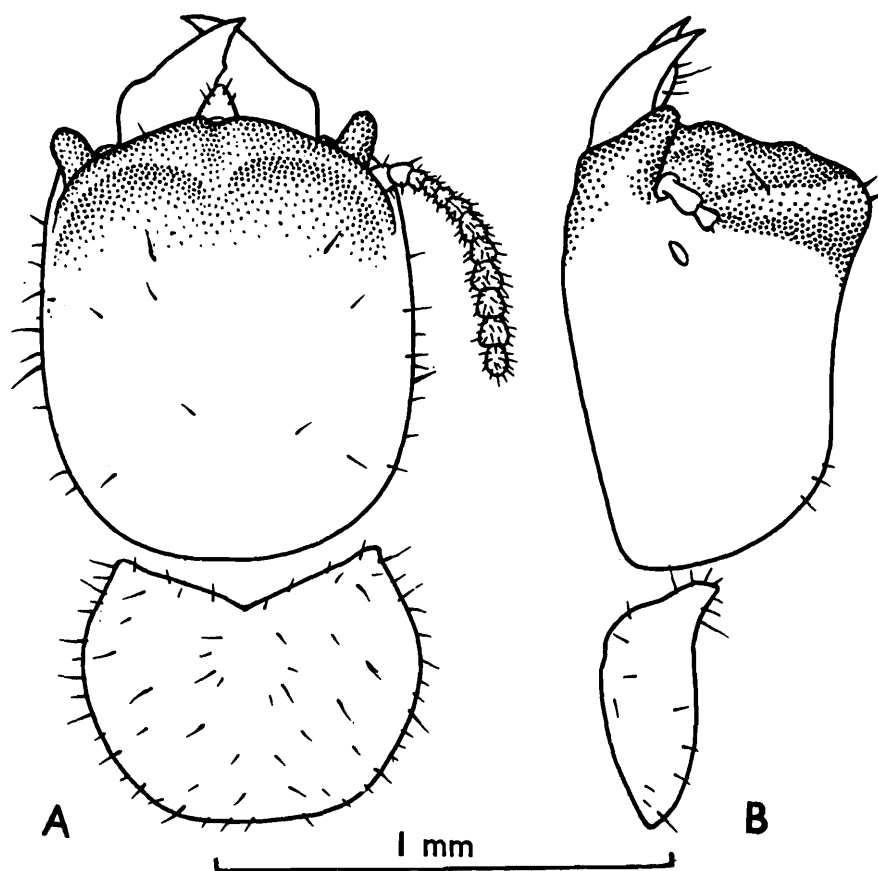

Fig. 205. *Cryptotermes domesticus*. Soldier (Lectotype). (A) Head and pronotum, dorsal view. (B) Same, side view. (Redrawn from Chhotani 1970).

1.01-1.30 mm, Length/Width ratio 0.64-0.74); anterior margin concave, notched medially, laterally projecting in front; sides rounded; posterior margin weakly outcurved. Meso- and metanotum narrower than pronotum and having weakly outcurved posterior margin. Legs short, hairy; forelegs shortest, hindlegs longest; apical tibial spurs 3:3:3; tarsi 4-jointed. Abdomen oblong hairy; cerci 2-jointed; styli single-jointed.

**PSEUDOWORKER** : Head whitish to yellowish; antennae, thorax, legs and body paler. Head-capsule subcircular, length to base of mandibles 0.90-1.07, width 1.00-1.07 mm. Antennae with 11-16 segments; segment 2 a little longer than half of 1. Clypeus flat, subtrapezoidal, not distinctly separated into ante- and postclypeus. Labrum broadly tongue-shaped, broadest in middle; hairy near anterior margin and on body. Mandible as in genus. Pronotum flat, subreniform; narrower to broader than head; length 0.38-0.57, width 0.70-0.90 mm; anterior margin concave; posterior margin weakly rounded, substraight medially. Legs and abdomen as in soldier.

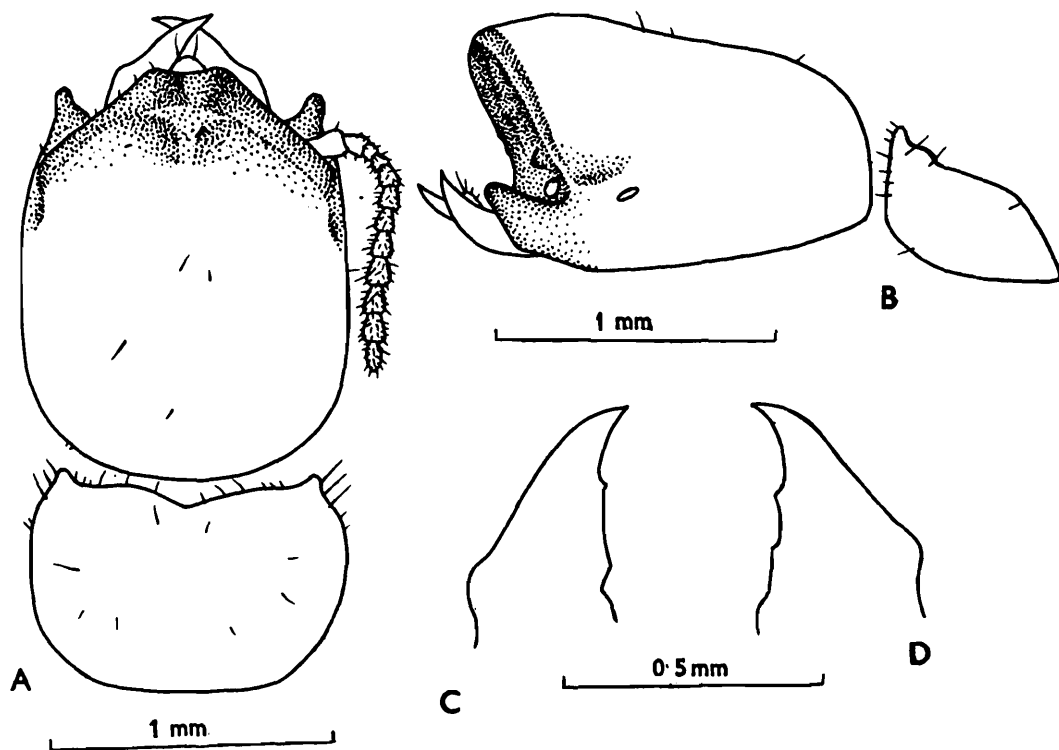

Fig. 206. *Cryptotermes domesticus*. Soldier. (A) Head and pronotum, dorsal view. (B) Same, side view. (C) and (D) Left and right mandibles. (Redrawn from Chhotani 1970).

**Distribution :** Widely distributed in the Oriental, Papuan, Australian and Neotropical regions. From the Indian subregion it is recorded only from Trivandrum, Kerala in India and from Colombo, Hakgala, and Peradeniya in Sri Lanka. For detailed distribution *vide* Chhotani, 1970.

**Biology :** *Cryptotermes domesticus* is a drywood termite and a serious pest of dry, seasoned woodworks in houses. It also occurs in cultivated trees and shrubs, makes narrow tunnels and ejects pellets of wood-dust and excrement.

### 56. *Cryptotermes dudleyi* Banks

(Figs. 207-209)

[Synonyms : *Planocryptotermes nocens* Light; *Cryptotermes thompsonae* Snyder; *Calotermes (Cryptotermes) secundus* Hill; *Cryptotermes (Planocryptotermes) primus* Kemner; *Cryptotermes* n. sp. (= *melloi* Ms name) Cherian and Margabundhu.]

1. *Cryptotermes dudleyi* Banks :

1918. Banks, *Bull. Am. Mus. nat. Hist.*, 38(Art. 17) : 660-661, pl. 5(fig. 3, Soldier). Im, S. Holotype : S, in Museum Comparative Zoology, Cambridge (Mass., U.S.A.) (Not traceable vide information dated 28th July 1964, from Dr. P.J. Darlington, Curator). Paratypes, however, in AMNH, New York and FRI, Dehra Dun, India (examined). Type-locality : Panama, Central America.
1949. Snyder, *Smiths. misc. Colls.*, 112: 41-42.
1961. Krishna, *Bull. Am. Mus. nat. Hist.*, 122(Art. 4) : 382.
1962. Fernando, In *Termites Humid Tropics* (Proc. New Delhi Symp., 1960) : 205, 206, 208.
1970. Chhotani, *Mem. zool. Surv. India*, 15(1) : 1, 4, 5, 8, 34-42, 54, 71, 76, 77. (Synonymy, descriptions, etc.)
1970. Roonwal, In *Biology of Termites* (ed. Krishna and Weesner) : 327-328.
1975. Chhotani, *Zool. Anz.*, 194: 119-123.
1976. Chhotani, *Newsl. zool. Surv. India*, 2(5): 211-212.
1979. Roonwal, *Termite Life and Termite Control in Tropical South Asia* : 51, 62, 78, 116, 121, 122.
1980. Chhotani, *Tech. Monogr. Zool. Surv. India*, No. 5, 24, 25.
1982. Gay and Watson, *Austr. J. Zool.*, (Suppl.), No. 88: 1, 2, 15-17, 41, 42, 52, 64.
1983. Maiti, *Occ. Pap. Rec. zool. Surv. India*, No. 42 : 40-42.
1984. He and Xia, *Contr. Shanghai Inst. Entomol.*, 1982-83 : 185-186.
1984. Bose, *Occ. Pap. Rec. zool. Surv. India*, No. 49 : 62, 64-66.
1987. Bacchus, *Trop. Pest Bull.*, No. 7: 2, 3, 4, 5, 8, 9, 10, 14, 22, 35, 42, 50, 53-54, 67, 76, 86, 87.

2. *Planocryptotermes nocens* Light :

1921. Light, *Philipp. J. Sci.*, 19(1): 42, 43-47, pl. 2. (figs. 3 & 4), pls. 5 & 6. Im, S, Ny and larva. Syntypes: In American Museum of Natural History, New York. Type-locality : Manila (Philippines).

3. *Cryptotermes thompsonae* Snyder :

1922. Snyder, *Proc. U.S. natn. Mus.*, 61(Art. 20) : 16-18, pl. 2 (figs. 4-9). Im, S. Holotype : Im, in U.S. National Museum, Washington. Type-locality: Ancon, Canal Zone (Panama).

4. *Calotermes (Cryptotermes) secundus* Hill :

1925. Hill, *Proc. roy. Soc. Victoria*, (N.S.), 37(2) : 215-216, pl. 23 (Fig. 16). Soldier. Holotype : S, in National Museum Victoria, Melbourne. Type-locality : Darwin, Northern Territory, Australia.

5. *Cryptotermes (Planocryptotermes) primus* Kemner :

1932. Kemner, *Ent. Tidskr.*, 53(2-3): 151-153, fig. 8. Imago and Soldier. Syntypes, in Zoologiska Institutet, Lund Univ., Lund (Sweden). *Type-locality* : Sri Lanka.

6. *Cryptotermes* n. sp. (= melloi MS. Name) :

1944. Cherian and Margabandhu, *Proc. 31st Indian Sci. Congr. (Abstr.)*, 31: 80-81.

Also see Chhotani (1970) for synonymy.

**IMAGO** (Figs. 207, 208) : Head-capsule pale reddish yellow or yellowish brown to pale brown; labrum, antennae and legs yellowish; thorax and abdominal tergites paler than head; sternites paler than tergites; wings with pale brownish tinge. Head and body moderately hairy. Total length with wings 8.5-10.1, without wings 4.6-6.00 mm. Head-capsule subrectangular, with eyes as wide as or slightly wider than length to base of mandibles (length 1.00-1.03, width 0.97-1.07 mm); Y-suture faint. Eyes oval, broader anteriorly, situated at about half their long diameter from lateral base; maximum diameter 0.30-0.33 mm. Ocelli oval, translucent; generally touching eyes, sometimes separated by thin line; length 0.10-0.13, width 0.07-0.10 mm. Antennae with 16-18 segments; segment 2 a little longer than half of 1, 3 generally shortest, sometimes as long as either 2 or 4.

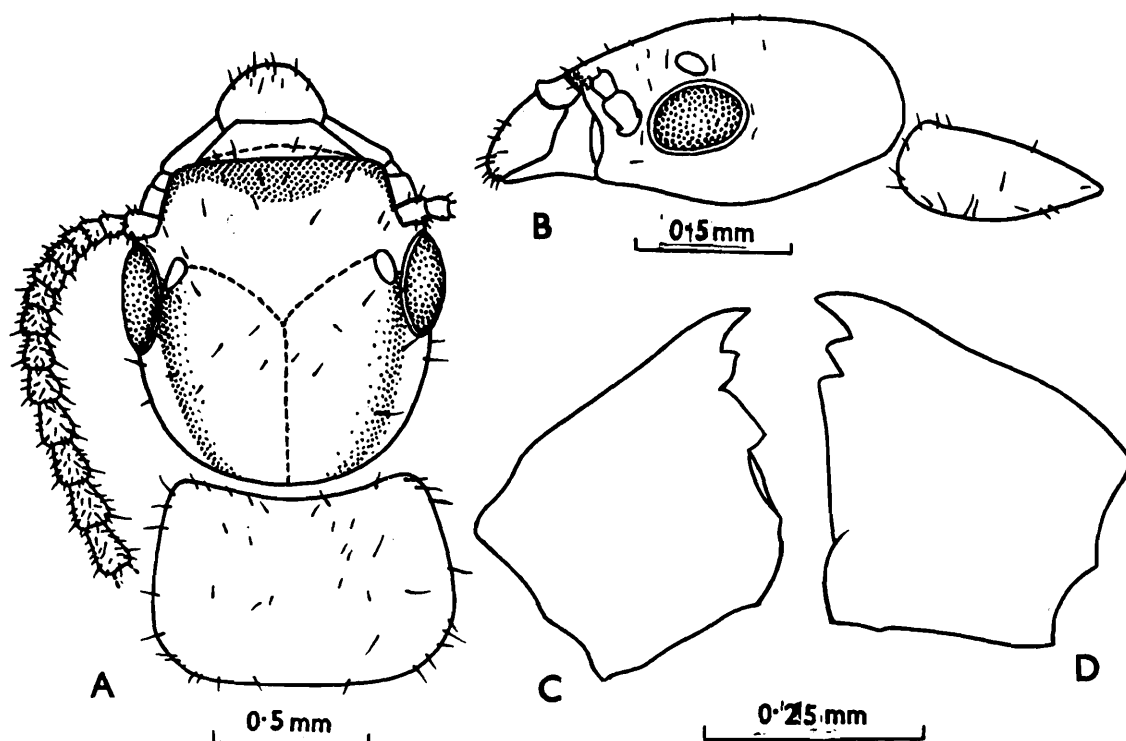

Fig. 207. *Cryptotermes dudleyi* Imago. (Paratype). (A) Head and pronotum, dorsal view. (B) Same, side view. (C) and (D) Left and right mandibles. (Redrawn from Chhotani 1970).

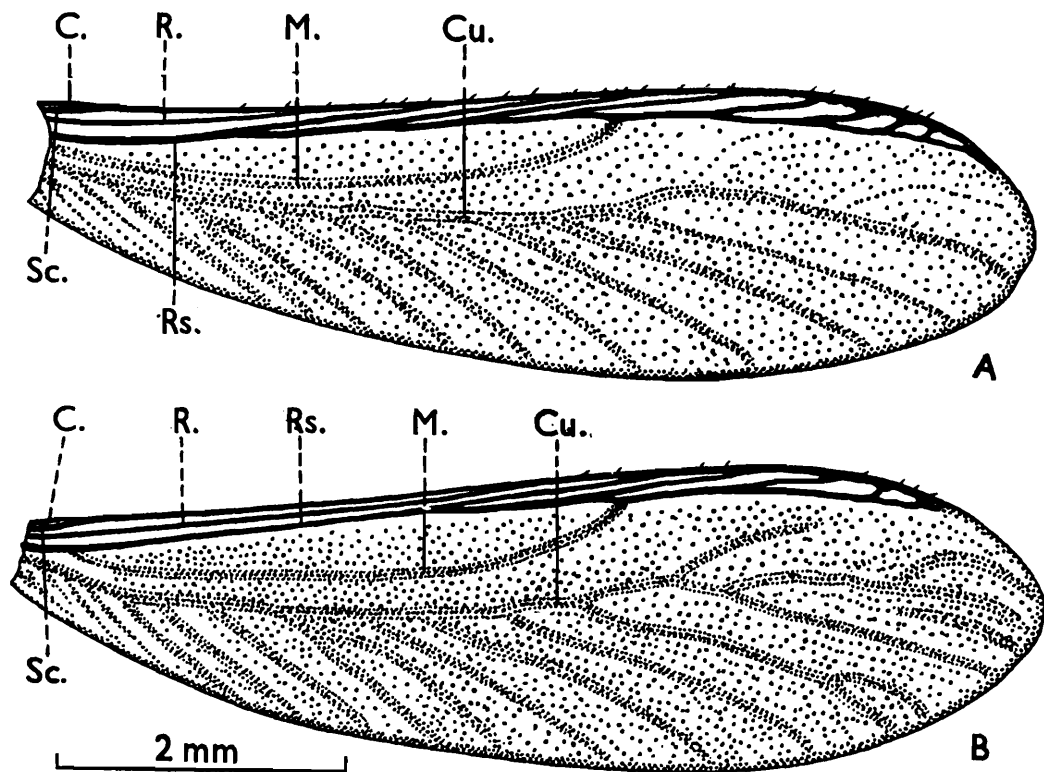

Fig. 208. *Cryptotermes dudleyi*. Wings. (A) Forewing. (B) Hindwing. Lettering same as in figure 204. (After Chhotani 1970).

Clypeus faintly separated into ante- and postclypeus; anteclypeus apilose, straight at distal margin; postclypeus sparsely pilose laterally and outcurved anteriorly. Mandibles typically *Cryptotermes*-type. Pronotum flat, subreniform, length 0.62-0.77, width 0.80-1.30 mm; somewhat narrower than head; anterior margin weakly incurved and posterior margin faintly outcurved and both without median notch; sides slightly rounded. Legs short, hairy; apical tibial spurs 3:3:3; tarsi 4-jointed; arolium present. Wings thin, membranous, faintly brownish; with papillae, pimpules and crescent-shaped tubercles. Forewing: 7.0-7.5 mm long. Radius fusing with costa between proximal fourth to one-third; radial sector with 5-8 branches to costa, first branching at about one-fourth of wing-membrane; media curving up to meet radial sector beyond middle between 2nd to 5th branches of

latter (abnormally bifurcating to send off a branch to distal tip in a paratype); cubitus with 11-13 branches to posterior margin. Hindwing : 6.25-6.75 mm long. Radius meeting costa at about middle or a little beyond; radial sector with 4 branches to costa; first branching near about middle of wing; media fusing with radial sector beyond middle between 1 to 3 branches of radial sector; cubitus as in forewing. Abdomen oblong, hairy, cerci 2-jointed; styli (in male) unsegmented.

**SOLDIER** (Fig. 209) : Head-capsule yellowish to dark brown, blackish anteriorly; mandibles dark reddish brown to nearly black; antennae, labrum, legs and body yellowish to pale brown; pronotum darker at anterior margin. Total length 4.3-6.1 mm. Head-capsule subrectangular, longer than broad, both lateral tubercles prominent; length to base of mandibles 1.60-1.80, width 1.20-1.43 mm; frontal ridge well marked, raised, somewhat pushed backwards; frons weakly concave and inclined at an angle of more than  $90^\circ$

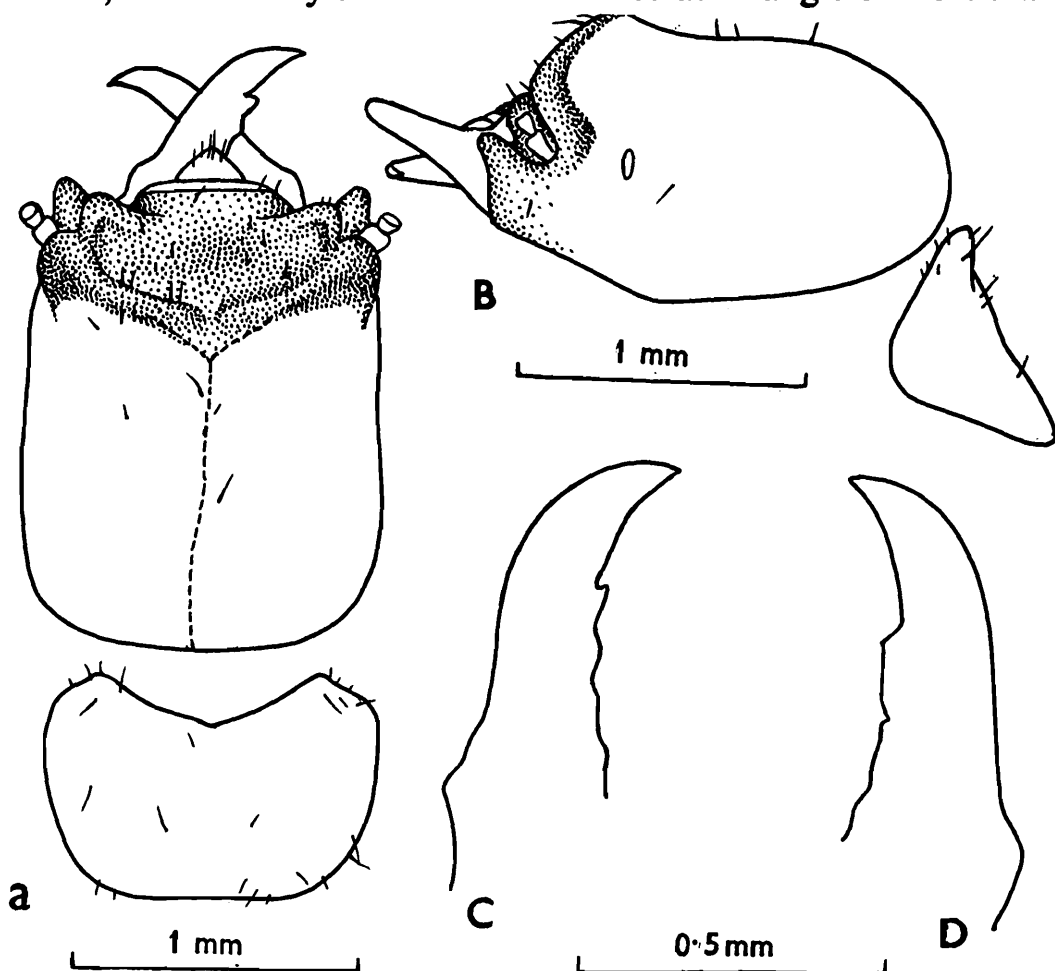

Fig. 209. *Cryptotermes dudleyi*. Soldier. (Paratype). (A) Head and pronotum, dorsal view. (B) Same, side view. (C) and (D) Left and right mandibles. (Redrawn from Chhotani 1970).

with mandibles; dorsum weakly depressed medially just behind frontal ridge; Y-suture present. Eye spots present, oval; 0.13-0.20 mm long. Antennae with 11-14 segments; segment 2 smaller than 1; 3 subequal to or shorter than 2; 4 shortest. Clypeus divided into ante- and postclypeus; anteclypeus thin, apilose, strip-like; postclypeus of same colour as head, with a few short hairs and hardly separable from frons. Labrum subtriangular, broad at base; with a few hairs near tip and on body. Mandibles thinner and longer (length 0.67-0.83 mm) than in other species of *Cryptotermes*, basal humps also weaker. Left mandible with 2-3 and right with 2, variably prominent marginal teeth. Postmentum longer than broad, broadest behind middle whence sides narrowing both anteriorly and posteriorly. Pronotum flat, slightly raised anteriorly; length 0.58-0.93, width 1.00-1.33 mm; narrower than head-capsule; anterior margin deeply and widely incurved, sometimes serrated; sides rounded or substraight; posterior margin faintly incurved medially. Mesonotum narrower than pronotum and metanotum narrower to a little wider than pronotum. Legs short, hairy; apical tibial spurs 3:3:3; tarsi 4-jointed. Abdomen oblong, hairy; cerci 2-jointed; styli single jointed.

**PSEUDOWORKER** : Head-capsule pale yellowish to pale yellowish brown, subcircular, slightly wider than length to base of mandibles; length 1.00-1.07, width 1.07-1.17 mm. Eye spots present, pale brown. Antennae with 11-15 segments. Anteclypeus apilose, anterior margin substraight; postclypeus with 3-4 short hairs and weakly outcurved anteriorly. Labrum broadly tongue-shaped, hairy at anterior margin and medially. Mandibles typically *Cryptotermes*-type. Pronotum flat, subreniform (length 0.50-0.60, width 0.80-1.06 mm); narrower than head-capsule; anterior margin incurved and medially notched. Legs and abdomen as in soldier.

**Distribution** : Widely distributed in the Oriental, Australian, Papuan, Ethiopian and Neotropical regions. From Indian subregion it is known from India, Sri Lanka and Bangladesh as follows: INDIA : Cannanore (Kerala); Barkuda Island, Chilka Lake (Orissa); Namkhana Range Headquarters and Jhingakhali in Sunderbans and Calcutta (West Bengal); Panjim (Goa); and Maya Bunder and Ross Island (Andaman Islands). SRI LANKA : Peradeniya; Kadugannawa; and Kandy. BANGLADESH : Khulna. For detailed distribution in different zoogeographical regions *vide* Chhotani

(1970). It is difficult to say anything definitive about the natural habitat of this species since it is quite common in the Oriental, Ethiopian and the Neotropical regions.

**Biology** : It is a serious pest of woodworks in houses, and is reported to damage furnitures, wooden poles, pillars, etc. It is generally confined to coastal areas but recently, however, a thriving colony of the species has been reported from Calcutta (Chhotani, 1970) from a wooden structure of a fairly new building. The swarming of alates from this colony is reported from March to May.

### 57. *Cryptotermes karachiensis* Akhtar (Figs. 210, 211)

#### 1. *Cryptotermes karachiensis* Chaudhry and Ahmad :

1972. Chaudhry and Ahmad, *Termites of Pakistan (Final Tech. Rep. PL. 480 Proj.)*: vii, 8 (Nom. nud.).

#### 2. *Cryptotermes karachiensis* Akhtar :

1974. Akhtar, *Biologia*, Lahore, 20(1): 33-37. Im, S. Holotype : S, in Dept. of Zoology, Panjab Univ., Lahore. *Type-locality* : Karachi, Pakistan.

1974. Akhtar, *Pakistan J. Zool.*, 6(1 & 2) : 101.

1987. Bacchus, *Trop. Pest Bull.*, No. 7: 3, 5, 9, 32, 59-60.

**IMAGO** (Fig. 210) : Head and pronotum pale reddish brown; anteclypeus yellowish white; labrum yellowish brown; antennae brownish yellow. Head sparsely hairy and pronotum with a few scattered bristles and short hairs on margins and body. Head-capsule subrectangular with sides subparallel; length to base of mandibles 0.95-0.97, width 1.00-1.01 mm; posterior margin weakly convex; Y-suture indistinct. Eyes slightly bulging, elongately oval (maximum diameter 0.33-0.36 mm). Ocelli oval (length 0.13-0.15, width 0.09-0.11 mm); almost touching eyes. Labrum wider than long; sides converging posteriorly, antero-lateral sides rounded, convex; anterior margin weakly convex. Mandibles as in genus. Antennal segments 2 and 3 subequal; 4 shorter than second. Pronotum subrectangular (length 0.59, width 0.98-1.01 mm); almost as broad as head; anterior margin shallowly concave; sides convex; posterior margin weakly emarginate medially. Tibial spurs 3:3:3; tarsi 4-jointed.

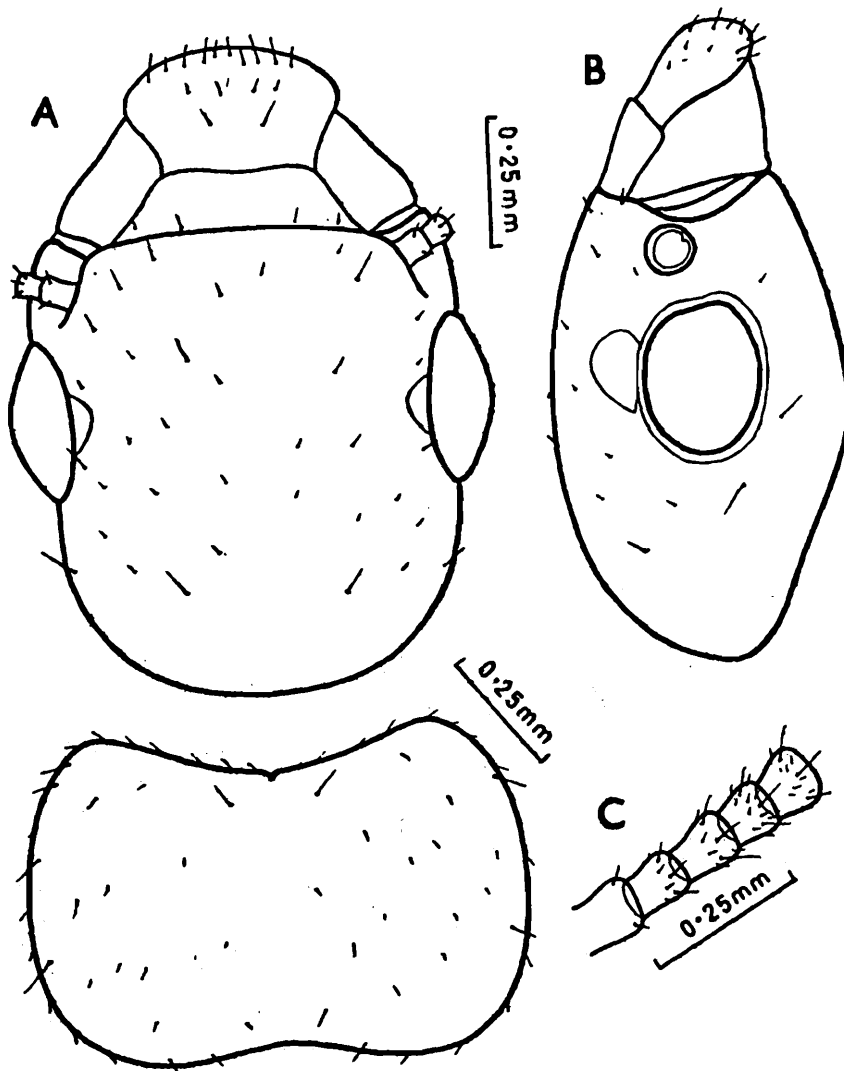

Fig. 210. *Cryptotermes karachiensis*. Imago. (A) Head and pronotum, dorsal view. (B) Head, side view. (C) Basal part of antenna. (After Akhtar 1974).

**SOLDIER** (Fig. 211) : Head dark brown getting darker anteriorly to almost black near frontal ridge; labrum brownish yellow and mandibles dark reddish brown; pronotum yellowish brown, a little darker anteriorly; legs brownish yellow; abdominal tergites pale brown. Head sparsely hairy; pronotum with bristles and short hairs along margins and on body. Head-capsule short, subrectangular, strongly phragmotic, almost as long as wide (length to base of mandibles 1.19-1.31, width 1.26-1.38 mm); Y-suture weakly indicated; frontal ridge prominent, notched in middle, slightly upturned back and over-hanging vertex at middle; vertex strongly depressed

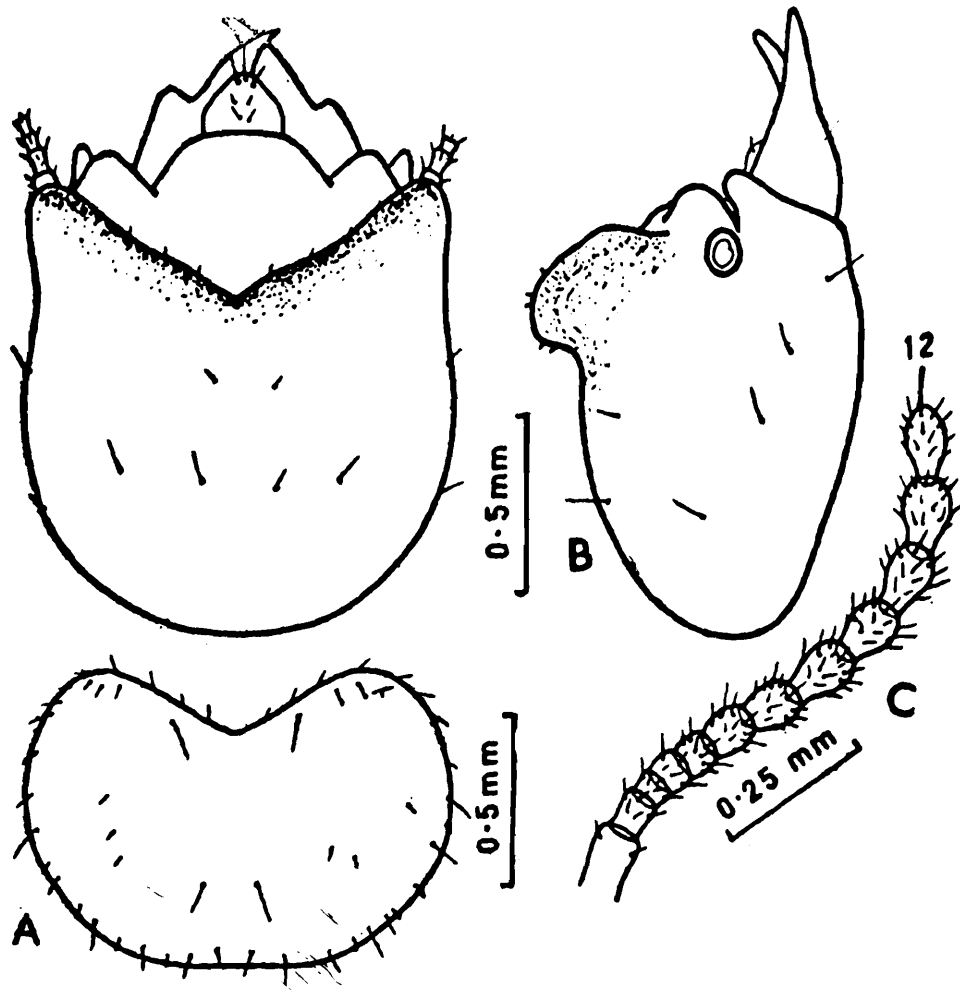

Fig. 211. *Cryptotermes karachiensis*. Soldier. (A) Head and pronotum, dorsal view. (B) Head, side view. (C) Antenna. (After Akhtar 1974).

behind frontal ridge; both lateral tubercles prominent, lower a little longer than upper. Eyes translucent; 0.11-0.15 mm long and 0.04-0.09 mm wide. Mandibles short, with distinct basal humps, teeth rudimentary. Labrum tongue-shaped, sides almost parallel, converging into a rounded tip. Antennae 10-13 segmented; segment 3 shortest. Pronotum subrectangular (length 0.61-0.74, width 1.23-1.44 mm); slightly narrower than head; anterior margin deeply concave; antero-lateral corners smooth and rounded; lateral sides round; posterior margin indistinctly depressed medially.

*Distribution* : Pakistan : Karachi (type-locality).

*Biology* : Inhabits coastal areas attacking dead portions of *Ficus* trees making irregular, narrow or wide inter-connected galleries. Imagoes have been collected in the month of March from *Ficus* sp.

**58. *Cryptotermes perforans* Kemner**  
(Figs. 212-214)

*Cryptotermes perforans* Kemner :

1932. Kemner, *Ent. Tidskr.*, 53: 153-155. Im, S. Lectotype: S, in Zoologiska Institutet, Lund Univ., Lund, Sweden (examined). *Type-locality* : Colombo, Sri Lanka.
1949. Snyder, *Smiths. misc. Colls.*, 112: 43.
1962. Fernando, In *Termites Humid Tropics* (Proc. New Delhi Symp., 1960) : 205, 208.
1970. Chhotani, *Mem. zool. Surv. India*, 15(1) : 1, 4, 5, 8, 20, 54-61, 64, 72, 78, 79, 81. (Detailed synonymy, descriptions, etc.)
1975. Chhotani, *Zool. Anz.*, 194: 119.
1979. Roonwal, *Termite Life and Termite Control in Tropical South Asia* : 51, 116.
1987. Bacchus, *Trop. Pest Bull.*, No. 7: 2, 3, 5, 8, 9, 19, 33, 47, 60, 69-70, 74, 78, 86.

**IMAGO** (Figs. 212, 213) : Head, thorax and abdominal tergites pale brownish yellow; antennae, labrum and legs pale yellow; sternites paler than tergites. Head and body sparsely hairy. Total length with wings 7.0-7.69, without wings 4.52-4.95 mm. Head-capsule subsquarish; with eyes almost as wide as length to base of mandibles (length 0.80, width 0.77-0.81 mm); sides subparallel; frons weakly depressed medially. Eyes oval, somewhat narrowed posteriorly; smaller, 0.27 mm in maximum diameter. Ocelli oval, translucent, touching the eyes; 0.10 mm long and 0.05 mm wide. Antennae with 13-14 segments; in 13-segmented antennae segment 3 large, longer and thicker than 4; in 14-segmented-ones 3 as long as but narrower than 4. Clypeus subtrapezoidal, not clearly differentiated into ante- and postclypeus. Labrum broadly tongue-shaped, broader than long (length 0.23, width 0.30 mm); hairy at anterior margin and on body. Mandibles not examined. Pronotum flat, subreniform, length 0.50, width 0.70 mm; narrower than head with eyes; anterior margin fairly incurved, median notch not present; posterior margin faintly incurved medially. Wings transparent, weakly tinged brownish; punctate (tuberculate). Forewing 6.15 mm long. Radius fusing with costa a little before one-fifth of wing membrane; radial sector with 6 branches to costa, first branching at about one-fifth of wing membrane; media meeting radial sector at about three-fifths of wing membrane; cubitus with 12 branches to posterior margin. Hindwing 5.45 mm long. Radius meeting costa a little before one-fourth of wing; radial sector with 4 branches to costa, first branching at about two-fifths of wing; media meeting

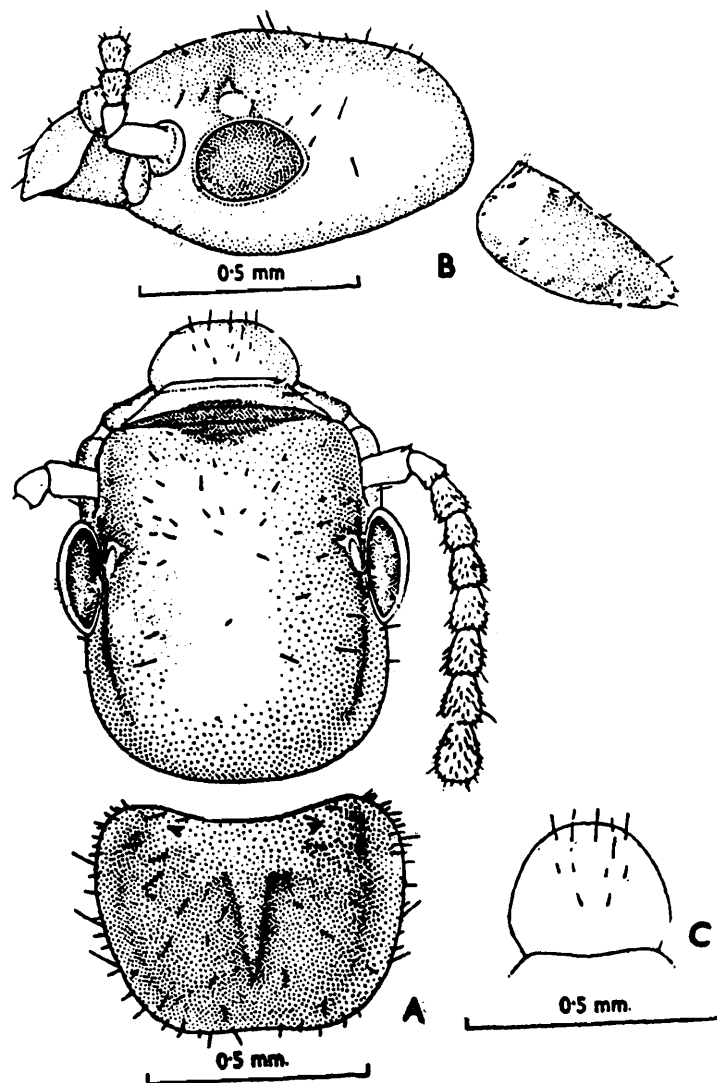

Fig. 212. *Cryptotermes perforans*. Imago (Lectomorphotype). (A) Head and pronotum, dorsal view. (B) Same, side view. (C) Labrum. (After Chhotani 1970).

radial sector at about distal third of wing; cubitus with 11 branches to posterior margin. Abdomen long, hairy; cerci 2-jointed; styli single-jointed.

**SOLDIER** (Fig. 214) : Head-capsule black, blackish brown posteriorly; antennae, labrum, legs and body pale brownish; pronotum dark brown at anterior margin; mandibles blackish, reddish black distally. Head sparsely and body fairly hairy. Total length 2.9-4.3 mm. Head-capsule thick and short (length to base of mandibles 0.97-1.03, width 0.90-1.00 mm); frons deeply incurved and truncated, and forming an angle of more than  $90^\circ$  with mandibles; frontal ridge prominent, forming a ribbon-like band; with two knob-like tubercles on either side, upper thick and long and lower short,

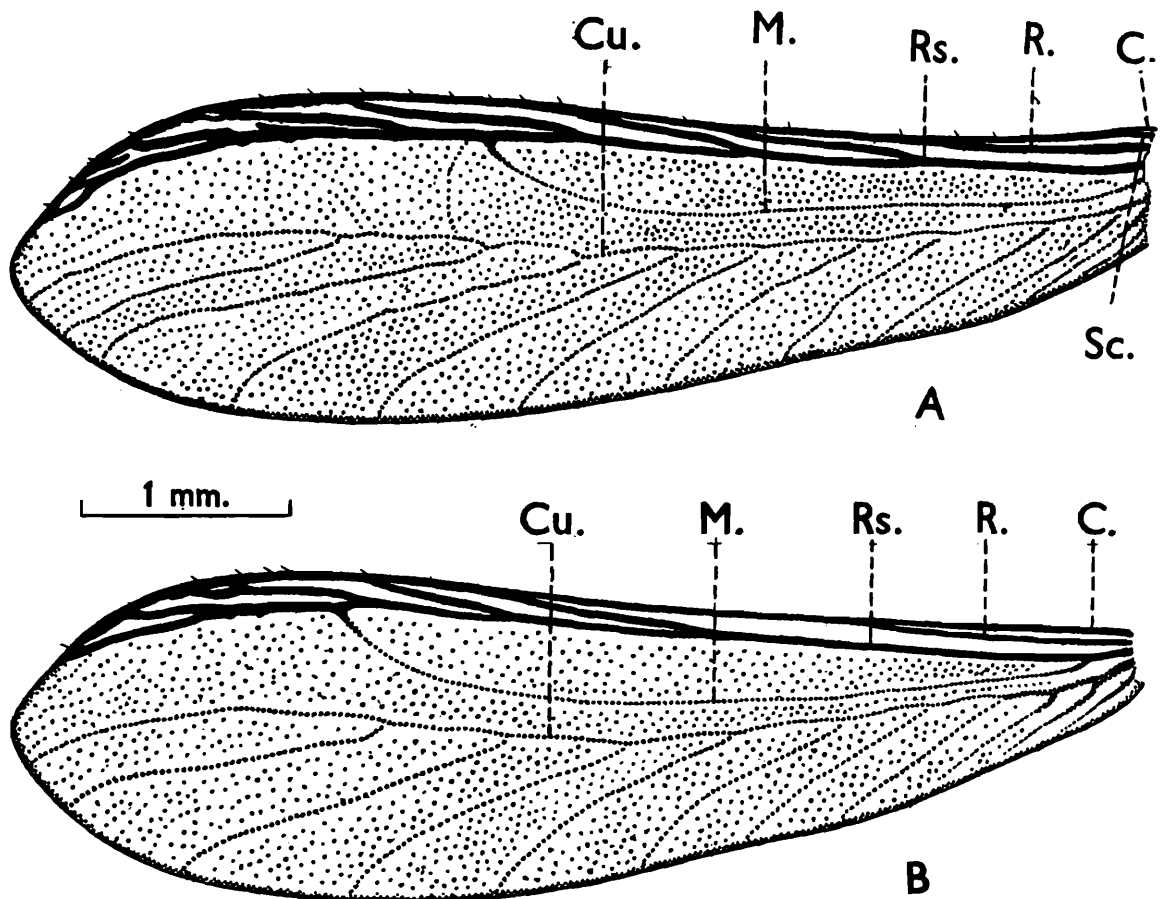

Fig. 213. *Cryptotermes perforans*. Wings (Lectomorphotype). (A) forewing. (B) Hindwing, Lettering same as in fig. 204. (After Chhotani 1970).

narrow and pointed; vertex with a median depression just behind frontal ridge. Eyes small, oval (0.07 mm in long diameter). Antennae with 10-11 segments; segment 2 about half of 1: 3 either subequal to or shorter than 2 (11-segmented antennae), sometimes subdivided (10-segmented antennae). Anteclypeus thin, hyaline, line-like; postclypeus subrectangular not clearly separated from frons. Labrum subtriangular, basally broader than its length; with a few bristles near tip. Mandibles short and thick, prominently humped on outer margin above the condyle; each with 2 small marginal teeth. Pronotum flat, with a slightly raised anterior margin; length 0.60-0.63, width 0.90-0.93 mm; narrower than head-capsule; anterior margin convex with a deep, broad, median notch; posterior margin weakly convex, substraight medially. Mesonotum and metanotum both narrower than

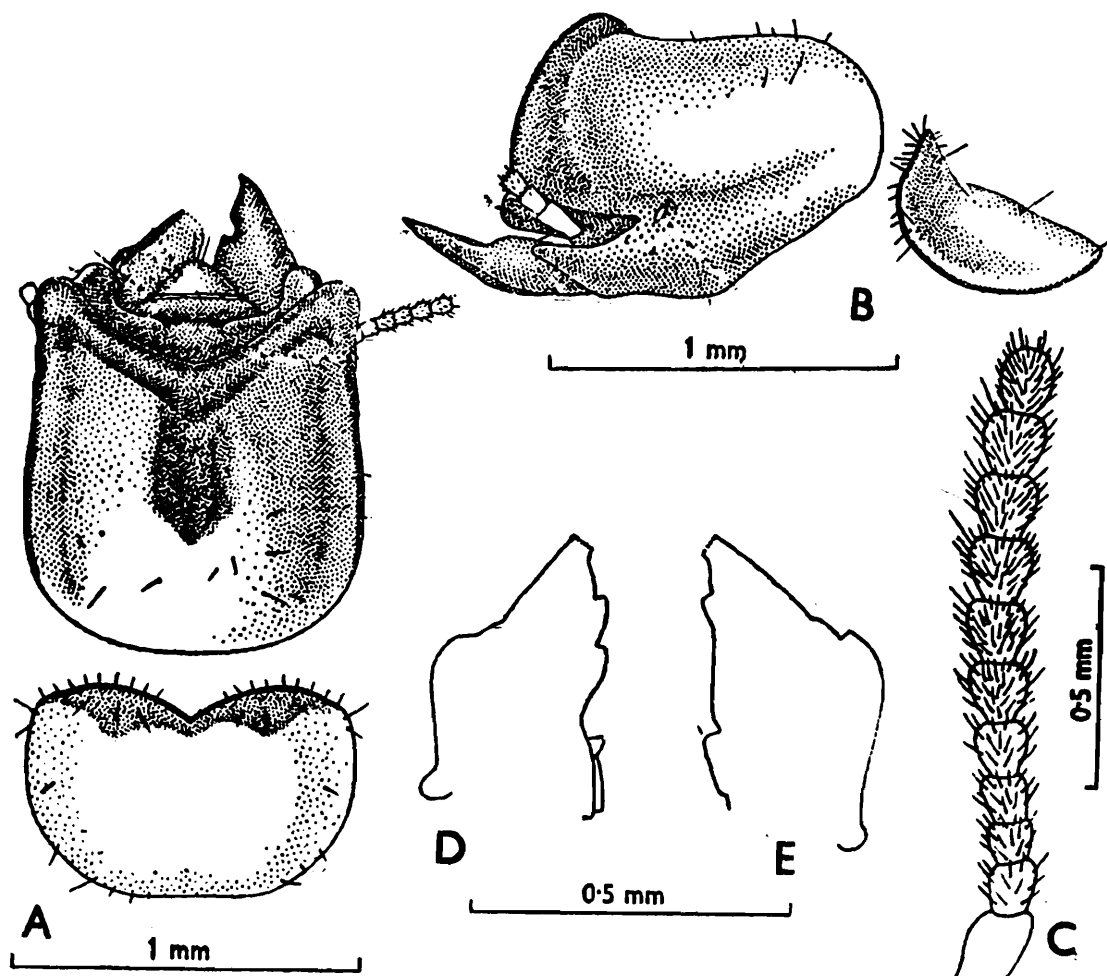

Fig. 214. *Cryptotermes perforans*. Soldier. (A) Head and pronotum, dorsal view. (B) Same, side view. (C) Antenna. (D) and (E) Left and right mandibles. (After Chhotani 1970).

pronotum and weakly incurved medially at posterior margins. Legs short and hairy; apical tibial spurs 3:3:3; tarsi 4-jointed. Abdomen oblong, hairy.

**PSEUDOWORKER** : Head-capsule yellowish to pale brown; subcircular, length to base of mandibles 0.77-0.83, width 0.85-0.90 mm. Eyes subcircular spots, 0.13-0.17 mm in diameter. Antennae with 11-13 segments; segment 3 either subequal to 2 or short and ring-like. Clypeus subtrapezoidal; anteclypeus apilose, strip-like; postclypeus pilose, weakly convex at anterior margin. Labrum broadly tongue-shaped; anterior margin rounded; with a few bristles near anterior margin and on body; length 0.21-0.30, width 0.33-0.40 mm. Mandibles typically *Cryptotermes*-type. Pronotum flat, subrectangular (length 0.40-0.43, width 0.73-0.83 mm); narrower than head; anterior margin incurved; posterior margin weakly incurved medially. Legs and abdomen as in soldier.

*Distribution* : SRI LANKA : Colombo, Galah and Talawila near Puttalam.

*Biology* : *Cryptotermes perforans* is common below 610 m altitude in Sri Lanka. It is a pest of dressed timber and is also reported from dead branches of *Syzygium cumini*.

### 59. *Cryptotermes roonwali* Chhotani (Figs. 215, 216)

*Cryptotermes roonwali* Chhotani :

1970. Chhotani, *Mem. zool. Surv. India*, 15(1): 1, 4, 5, 61-64, 72. S, Pw. Holotype : S, in FRI, Dehra Dun, India. *Type-locality* : Beliapatam (N. Malabar, Kerala).

1975. Chhotani, *Zool. Anz.*, 194: 119.

1979. Roonwal, *Termite Life and Termite Control in Tropical South Asia* : 116.

1984. Bose, *Occ. Pap. Rec. zool. Surv. India*, No. 49: 62, 69-70.

1987. Bacchus, *Trop. Pest Bull.*, No. 7: 3, 5, 9, 28, 34, 47, 70, 73-74.

IMAGO : Not known.

**SOLDIER** (Fig. 215) : Head-capsule blackish anteriorly; antennae, labrum and body pale yellowish brown; pronotum brownish at anterior margin; mandibles blackish. Head and body sparsely hairy. Total length 4.0-4.7 mm. Head-capsule thick, subrectangular, phragmotic, a little longer than its width (length to base of mandibles 1.10-1.17, width 1.10-1.13 mm); frontal ridge weak; frons incurved, inclining at an angle of more than 90° with mandibles; vertex weakly depressed medially behind frontal ridge; epicranial suture present; both tubercles present, upper one thicker and longer; lower short, narrow. Eye-spots paler than head, situated a little behind antennal sockets. Anteclypeus pale yellow, narrow, strip-like, apilose; postclypeus as dark as frons and hardly demarcated from it. Labrum subtriangular, broad basally; length 0.08-0.13, width 0.13-0.20 mm; with a pair of small bristles at tip. Mandibles short, thick and triangular, pointed apically (length 0.31-0.37 mm); basal hump above outer condyle weak; each mandible with 2 small, rudimentary, marginal teeth. Postmentum short, swollen, posteriorly rounded at corners and posterior margin with a sharp notch; anteriorly faintly incurved. Pronotum as wide as head, flat, slightly raised at anterior margin; length 0.66-0.70, width 1.00-1.02 mm; anterior margin broadly and deeply notched medially; sides rounded; posterior margin outcurved, without notch. Mesonotum narrower and metanotum as wide as pronotum. Legs short, thick, pilose; apical tibial

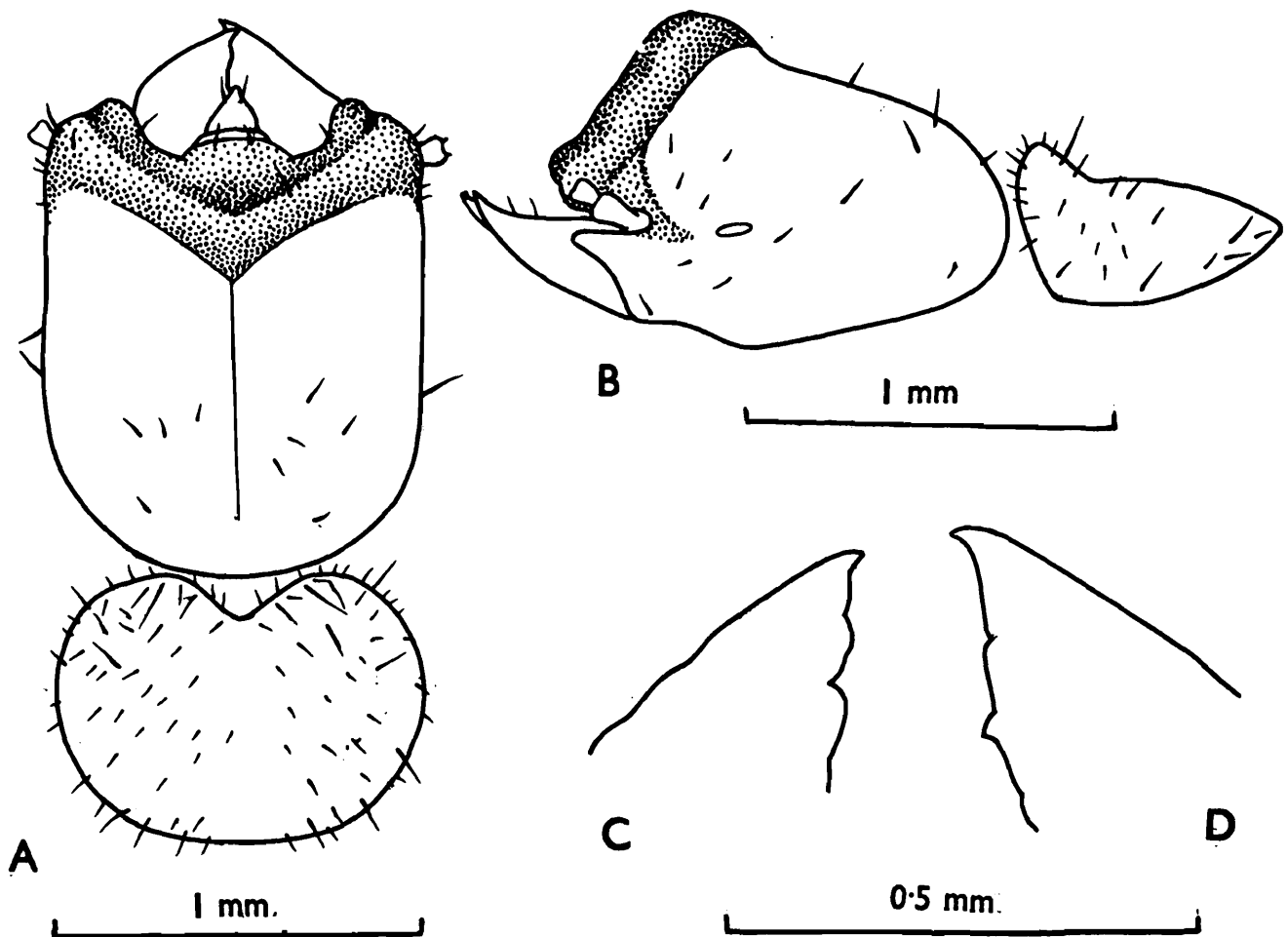

Fig. 215. *Cryptotermes roonwali*. Soldier (Paratype). (A) Head and pronotum, dorsal view. (B) Same, side view. (C) and (D) Left and right mandibles. (Redrawn from Chhotani 1970).

spurs 3:3:3; tarsi 4-jointed. Abdomen oblong, sparsely hairy; cerci 2-jointed, styli unsegmented.

**PSEUDOWORKER** (Fig. 216): Head yellowish brown; antennae, labrum, legs and body pale yellow. Head-capsule subcircular; length to base of mandibles 0.87-0.90, width 0.87-0.90 mm. Eye-spots faint, broadly oval 0.10-0.13 mm in maximum diameter. Antennae with 12-13 segments; segment 2 a little shorter than 1; 3 shorter than 2; 4 shortest. Anteclypeus thin, narrow, apilose; postclypeus flat, with a few bristles and anteriorly faintly outcurved. Labrum broadly tongue-shaped; length 0.27-0.30, width 0.33-0.37 mm; pilose near anterior margin and on body. Mandibles typically *Cryptotermes*-type. Pronotum flat, narrower than head (length 0.47-0.53, width 0.80-0.87 mm); weakly incurved at anterior margin; sides

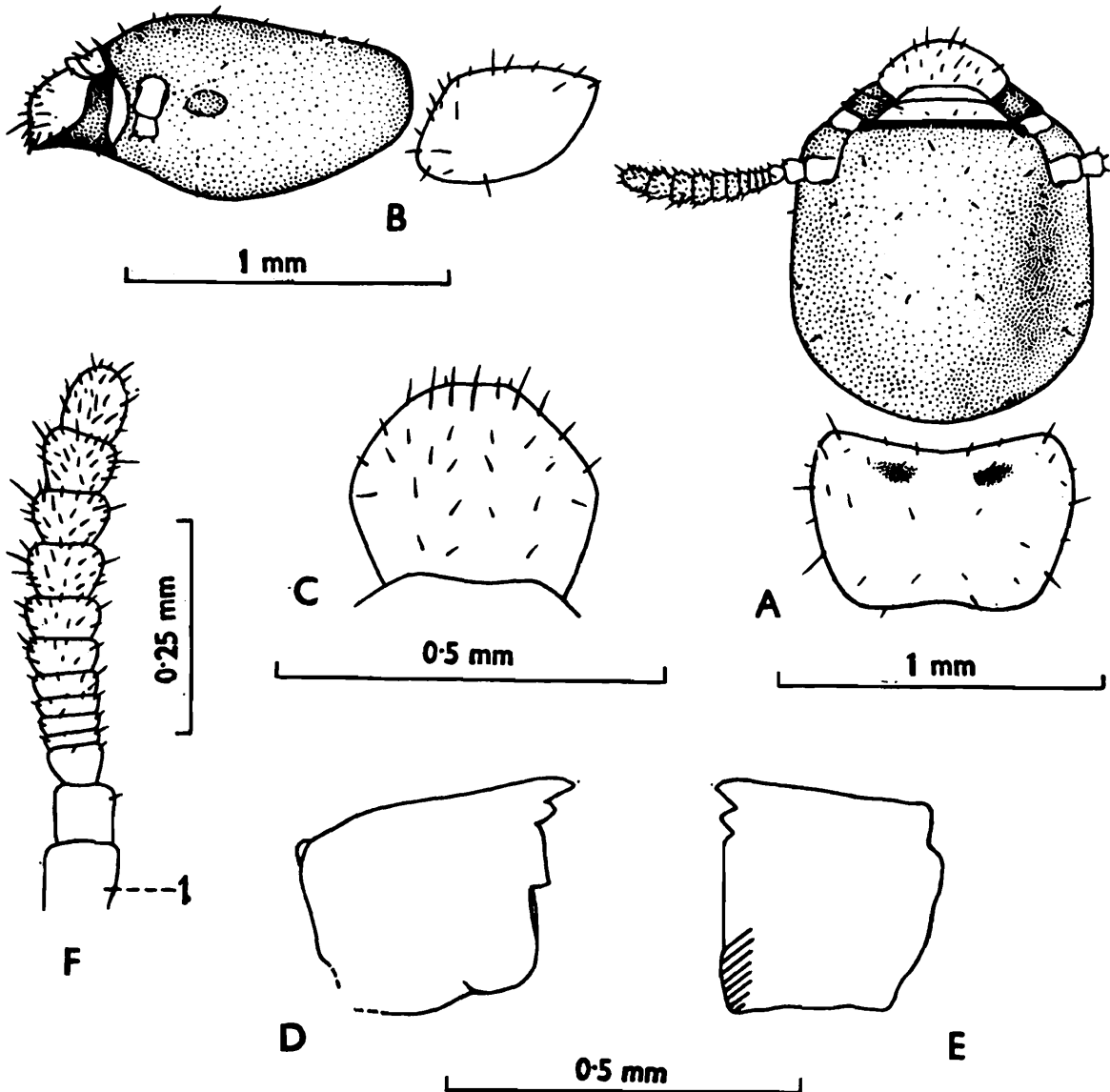

Fig. 216. *Cryptotermes roonwali*, Pseudoworker. (A) Head and pronotum, dorsal view. (B) Same, side view. (C) Labrum. (D) and (E) Left and right mandibles. (F) Antenna. (After Chhotani, 1970).

rounded and posterior margin slightly incurved medially. Legs and abdomen as in soldier.

**Distribution :** INDIA : Known only from the type-locality i.e., Beliapatam (N. Malabar, Kerala state.)

**Biology :** It is reported from sawn scantlings of *Vateria indica*.

**Family IV. RHINOTERMITIDAE Froggatt**  
(Syn : Mesotermitidae Holmgren)

1. Subfamily Rhinotermitinae (of Termitidae) Froggatt :
  - 1896. Froggatt, *Proc. Linn. Soc. N.S.W.*, 21: 518.
  - 1920. Banks and Snyder, *Bull. U.S. natnl. Mus.*, No. 108: 39.
2. Subfamily Termitinae (in part) :
  - 1903. Silvestri, *Redia*, 1: 37.
  - 1904. Desneux, *Ann. Soc. Ent. Belg.*, 48(8): 285-286.
  - 1904. Desneux, In P. Wytman, *Gen. Insect.*, Fasc. 25: 9, 25-26.
  - 1920. Banks and Snyder, *Bull. U.S. natnl. Mus.*, No. 108: 54.
3. Tribe Rhinotermitini Desneux :
  - 1904. Desneux, *Ann. Soc. Ent. Belg.*, 48(8): 285-286.
4. Suborder Cryptoclidoptera (in part) :
  - 1909. Enderlein, *Zool. Anz.*, 35: 171.
5. Family Mesotermitidae Holmgren :
  - 1909. Holmgren, *K. Sv. Vet. Akad. Handl.*, 44(3): 100.
  - 1910. Holmgren, *Zool. Anz.*, 35: 285.
  - 1910. Holmgren, *Trans. Linn. Soc. Lond. Zool.*, (2) 14(8): 143 (in part).
  - 1911. Holmgren, *K. Sv. Vet. Akad. Handl.*, 46(6): 13, 61-84. (Including Serritermitinae).
6. Termitidae (part) :
  - 1919. Banks, *Bull. Mus. Comp. Zool. Harvard College*, 62(10): 475, 479.
  - 1920. Banks and Snyder, *Bull. U.S. natnl. Mus.*, No. 108: 5.
7. Family Rhinotermitidae Froggatt :
  - 1921. Light, *Philipp. J. Sci.*, 18(3): 246.
  - 1921. Light, *Philipp. J. Sci.*, 19(1): 25, 48.
  - 1924. Light, *China J. Sci. Arts*, 2(1-4): 52.
  - 1925. Sjöstedt, *K. Sv. Vet. Akad. Handl.*, (3) 3(1): 45.
  - 1934. Kemner, *K. Sv. Vet. Akad. Handl.*, 13(4): 49-50.
  - 1949. Snyder, *Smiths. misc. Coll.*, 112: 64.
  - 1950. Ahmad, *Bull. Am. Mus. nat. Hist.*, 95(Art. 2): 53-56.
  - 1953. Rattan Lal and Menon, *Catal. Indian Insects*, Part 27, *Isoptera* : 20-23.
  - 1955. Emerson, *Fieldiana : Zool.*, 37: 505, 506, 507, 509.

1962. Roonwal and Chhotani, *Indian Species of Termite Genus Coptotermes* (ICAR Ent. Monogr. 2) : 3.
1955. Weidner, In *Die Termiten* (Ed. Schmidt) : 10, 39, 54.
1958. Ahmad, *Biologia*, Lahore, 4(1-2): 34, 35, 58-60.
1961. Harris, *Termites : Recognition and Control*: 38, 45-48. (2nd Ed., 1971).
1970. Weidner, *Handb. d. Zool.*, 4: 12, 20.
1970. Krishna, In *Biology of Termites* (Eds. Krishna and Weesner) Vol. 2: 137-139.
1970. Roonwal, In *Biology of Termites* (Eds. Krishna and Weesner) Vol. 2: 332-342.
1971. Emerson, *Bull. Am. Mus. nat. Hist.*, 146(Art. 3): 248-296.
1972. Chhotani, In *Termite Problems in India* (Ed. Roonwal): 24.
1973. Chhotani and Bose, *Zool. Anz.*, 190(3-4): 232, 233, 234.
1975. Emerson and Krishna, *Amer. Mus. Novit.*, No. 2570: 12-29. (Comparison of *Serritermes* with Rhinotermitid genera, etc.)
1979. Roonwal, *Termite Life and Termite Control, etc.*: 4, 9, 10.
1983. Roonwal, *Proc., Indian natnl. Sci. Acad.*, (B) 49(5): 363-364, 367, 373, 379, 382, 383, 387.
1983. Maiti, *Occ. Pap. Rec. zool. Surv. India*, No. 42: 16, 22.
1983. Chhotani, *Oriental Insects*, 17: 110-115.
1984. Bose, *Occ. Pap. Rec. zool. Surv. India*, No. 49: 5-6, 14, 77-78.
1985. Chhotani, *Z. ang. Ent.*, 100: 91-94.
1986. Grassé, *Termitologia* Vol. 3: 518. (Authorship of family assigned to Light 1921).

Type genus : *Rhinotermes* Hagen.

### 1. Characters of Family Rhinotermitidae

*Imago* : Head oval to round; epicranical sutures often present. Fontanelle always present. Eyes and ocelli small to moderately large, latter sometimes not distinct (some *Heterotermes*). Antennae 14-22 segmented. Postclypeus small and flat to large and swollen. Mandibles each with an apical and three marginal teeth; 2nd marginal of left mandible variable in size, either equal to or shorter than first; right with the 1st rudimentary subsidiary tooth at anterior base of 2nd marginal. Pronotum flat. Forewing scale longer than hindwing scale except in *Psammotermes*. Wing membrane generally reticulate, either with a few or covered densely with hairs; either

strongly or faintly iridescent; wing microsculpturing consists of five types of structures, namely papillae, pimpules, arrowheads, tubercles and micrasters, except for papillae others may or may not be present in the same species (vide note infra). Legs elongate and hairy, apical tibial spurs 3:2:2, dorsal spur in foreleg sometimes very small; tarsi 4-jointed. Cerci-2-segmented, styli in male present.

*Note on wing microsculpturing* : The five types of microsculpturing elements which occur on wing surfaces (vide supra) are found in the following combinations : (1) Only papillae : Some Rhinotermitinae (most *Schedorhinotermes*); (2) Only papillae and pimpules : Psammotermitinae, some Rhinotermitinae (a few *Schedorhinotermes*, *Rhinotermes*) and some Coptotermitinae; (3) Only papillae and arrowheads : *Prorhinotermes*; (4) Papillae, pimpules and tubercles : Some Rhinotermitinae (*Dolichorhinotermes*); (5) Only papillae and micrasters : Some Heterotermitinae, some Coptotermitinae and Termitogetoninae; (6) Papillae, pimpules and micrasters : Some Coptotermitinae.

Papillae are usually finger-like (occasionally shallow and subcrescentic) but sometimes pointed and spiky. Different shapes may occur in the same genus (finger-like in *Heterotermes gertrudae*, spiky in *H. indicola*). Arrowheads and tubercles occur rarely. Pimpules are frequently present, occurring all over membrane or in restricted areas; may be present or absent in the same genus (*Schedorhinotermes*). Micrasters both simple and complex, occur in higher groups (some Heterotermitinae, some Coptotermitinae and Termitogetoninae), may be present or absent in the same genus (*Coptotermes*). (Roonwal 1983c, 1985, 1986, SEM study; Roonwal and Rathore 1982; Roonwal, Verma and Thakur 1979b; Roonwal and Verma 1983).

*Soldier* : Monomorphic or dimorphic. Head variable in shape, either oval or subsquarish or rectangular. Fontanelle always present, gland prominent. Eyes generally absent, sometimes indistinctly present. Ocelli absent. Antennae with 12-19 segments. Labrum variable in shape; sometimes with a fringe of hairs at anterior margin. Mandibles generally elongate; with or without marginal teeth; sometimes only with a few crenulations. Pronotum generally flat; anterior margin projecting in front in some genera (*Schedorhinotermes*). Legs elongate; apical tibial spurs 3:2:2,

dorsal spur of foretibia sometimes rudimentary and hardly discernible, rarely 2:2:2 (*Glossotermes*); tarsi 4-jointed. Abdomen elongate; cerci 2-jointed; styli single-jointed, often present.

*Worker* : Head subcircular or subsquarish. Fontanelle with fontanelle plate present, sometimes not distinct. Antennae with 12-18 segments. Postclypeus variable, either flat or swollen. Mandibles as in imago. Pronotum flat or saddle-shaped. Legs and abdomen as in soldier.

## 2. Distribution and Composition of Rhinotermitidae

*Distribution* : Living (Fig. 217) : The moderately large family Rhinotermitidae is widely distributed all over the world and is reported from all the zoogeographical regions. The main concentration of genera is in the tropical and subtropical parts with a few extending to subtemperate and temperate regions while the genus *Reticulitermes*, which is mainly Palearctic, extends into tropical India and southern China. For a discussion on distribution and zoogeography of Oriental genera see Chhotani 1985.

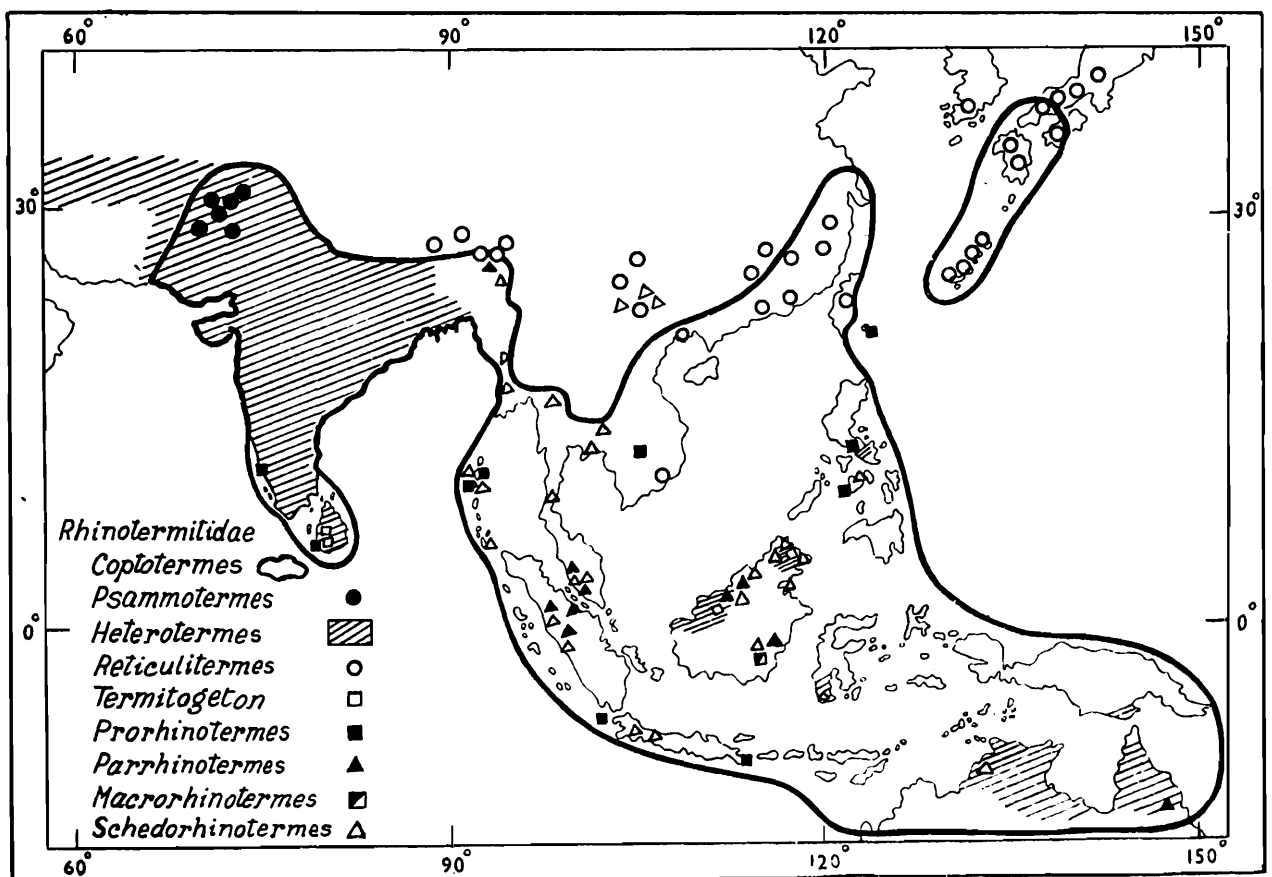

Fig. 217. Map of the Oriental Region showing distribution of Rhinotermitidae genera.

Fossils : Fossils of genera *Coptotermes*, *Heterotermes*, *Reticulitermes* and *Schedorhinotermes* are known. *Coptotermes* is reported from Oligocene - Miocene amber, Chiapas, Mexico and Dominican Republic; *Heterotermes* from Oligocene-Miocene amber, Chiapas, Mexico; *Reticulitermes* from Lower Oligocene to Upper Miocene beds in Europe and U.S.A. and *Schedorhinotermes* from Pleistocene periods.

*Composition* : The family includes the following 5 subfamilies and members of all of which occur in the Indian Region.

1. Psammotermitinae Holmgren
2. Heterotermitinae Froggatt
3. Coptotermitinae Holmgren
4. Termitogetoninae Holmgren
5. Rhinotermitinae Froggatt

Some authors also add to this a sixth subfamily, Stylotermitinae Holmgren and Holmgren, which, however, is distinguished by several unique characters (including the 3-segmented tarsi), and we, therefore, treat it here as a separate family Stylotermitidae.

Quennedey and Deligne (1975) have placed the genus *Prohrinotermes* in a separate subfamily, their Prohrinotermitinae. We think, however, that this change has been made on insufficient grounds.

### 3. Keys to the Subfamilies of Rhinotermitidae IMAGOES

- 1(2) Forewing scale not longer than that of hindwing ..... **Psammotermitinae**
- 2(1) Forewing scale longer than that of hindwing
- 3(4) Postclypeus strongly swollen, mostly projected in front medially; a median groove running from fontanelle onwards upto tip of labrum or sometimes stopping short..... **Rhinotermitinae**
- 4(3) Postclypeus flat or weakly swollen, not projected in front medially, without any median groove running from fontanelle onwards
- 5(6) Head triangular; pronotum very small, with anterior margin sharply projected medially ..... **Termitogetoninae**
- 6(5) Head round or oval; pronotum large, without any projection in front

- 7(8) Head oval, sides substraight ..... **Heterotermitinae**  
 8(7) Head rounded, sides also rounded ..... **Coptotermitinae**

### SOLDIERS

- 1(2) Head triangular and strongly flattened; dorso-ventrally posterior margin strongly incurved but projected medially. Head and body profusely hairy. Pronotum small, sharply projected in front medially, appearing fan-shaped ..... **Termitogetoninae**  
 2(1) Head subsquarish or rectangular or oval, not flattened; posterior margin generally rounded or slightly wavy; head and body weakly or moderately hairy. Pronotum larger, flat or slightly saddle-shaped.  
 3(6) Head subsquarish or rectangular  
 4(5) Dimorphic or trimorphic. Head subsquarish to subrectangular; mandibles with many marginal teeth; labrum very broad medially and with a strong medial projection in larger soldiers ..... **Psammoterritinae**  
 5(4) Generally monomorphic, sometimes dimorphic. Head subrectangular; mandibles without teeth or with a few crenulations at base; labrum triangular, sometimes with a needle-like projection at apex ... **Heterotermitinae**  
 6(3) Head oval or roundly oval  
 7(8) Monomorphic or dimorphic. Mandibles each with 1-2 sharply pointed teeth. Fontanelle situated forwardly in between antennal carinae, with a groove running from it usually upto tip of labrum or upto base of clypeus ..... **Rhinotermitinae**  
 8(7) Monomorphic. Mandibles with only a few crenulations in basal half. Fontanelle large, situated at base of clypeus, without any groove running onwards ..... **Coptotermitinae**

#### Subfamily (i) PSAMMOTERMITINAE Holmgren

##### 1. Psammotermitinae : Holmgren :

1911. Holmgren, *K. Sv. Vet. Akad. Handl.*, 46(6): 62, 64, 66-68.

1949. Snyder, *Smiths, misc. Colls.*, 112: 64.

1950. Ahmad, *Bull. Am. Mus. nat. Hist.*, 95(Art. 2): 53.

1955. Weidner, In *Die Termiten* (Ed. Schmidt): 19, 39, 40, 41, 54, 92.

1961. Harris, *Termites : Their Recognition & Control* : 38, 45-46. (2nd Edition 1971).

1965. Bouillon and Mathot, *Zooleo*, No. 1: 20.

1970. Krishna, In *Biology of Termites* (Eds. Krishna and Weesner) Vol. 2: 131, 137, 138.

1970. Roonwal, In *Biology of Termites* (Eds. Krishna and Weesner) Vol. 2: 332.
1971. Emerson, *Bull. Am. Mus. nat. Hist.*, 146(Art. 3): 248.
1977. Chhotani, *Proc. 8th int. Cong. Int. Un. Study Social Ins.* (Wageningen, Sept. 1977): 116, 117.
1979. Roonwal, Verma and Thakur, *Proc. Indian natn. Sci. Acad.*, (B) 45(4): 332, 333, 352.
1983. Roonwal, *Proc. Indian natn. Sci. Acad.*, (B) 49(5): 363, 367, 379, 383, 389.
1983. Chhotani, *Orient. Insects*, 17: 111, 112, 119.
1985. Chhotani, *Z. ang. Ent.*, 100: 93.
1986. Grassé, *Termitologia* Vol. 3: 518-519.
2. Calotermitinae (in part) :
1904. Desneux, In Wytman's *Gen. Insect.*, Fasc. 25: 24.
3. Leucotermitinae (= Heterotermitinae) in part :
1910. Holmgren, *Zool. Anz.*, 35: 285.

Type genus *Psammotermes* Desneux

### 1. Characters of Subfamily *Psammotermitinae*

Imago and worker characters are based on genus *Psammotermes* only as these castes are not known in the other genus, *Glossotermes* Emerson, belonging to this subfamily.

*Imago* : Head broadly oval, dorso-ventrally flattened. Fontanelle large, round, prominent, situated medially. Antennae narrowing distally; with 15-17 segments; segment 3 subequal to or shorter than 4. Eyes small, blackish. postclypeus short, convex; length less than half of width. Labrum broad, tongue-shaped. Mandibles each with an apical and 3 marginal teeth. Left mandible : Apical finger-like; 1st marginal shorter than apical; 2nd subequal to apical; 3rd shorter than 2nd, directed backwards and with long anterior margin. Right mandible: Apical as in left mandible; 1st marginal rudimentary lying at base of 2nd marginal; 2nd about as long as apical; 3rd short with a long posterior margin; molar plate shorter than posterior margin of 3rd marginal. Pronotum flat, narrower than head; slightly raised at anterior margin. Wings short, moderately broad; membrane transparent, practically hairless, both surfaces covered with 2 types of microsculpturing elements e.g., papillae and pimples in considerable density; no micrastrs

present (vide note *infra*). Forewing and hindwing scales subequal. Forewing: Costa thick, running along anterior margin; subcosta indistinct; radius close and parallel to costa, joining it at distal end; media and cubitus joined together separating just before middle of wing. Cubitus with 6-10 branches. Hindwing: Costa, subcosta and radius as in forewing; media separating from radius just outside scale. Cubitus arising separately and with 6-10 branches. Legs with 3:2:2 apical tibial spurs and 4-jointed tarsi. Abdomen elongate. Styli present in male.

*Note on wing microsculpturing in Psammotermittinae* : Wing microsculpturing occurs on both surfaces but is simple and consists of only 2 elements: (1) papillae of 2 types e.g. shallow ones (3.0-7.5  $\mu\text{m}$  long, density c 3140-3430/ $\text{mm}^2$ ) in 2-3 rows at anterior margin and longer ones (4.5-8.0  $\mu\text{m}$ ), in 1-2 rows at the posterior margin. (2) Pimples small and hyaline (1.5-4.5  $\mu\text{m}$ , density 2860-3860/ $\text{mm}^2$ ). Micrasters absent. Wings almost hairless (Roonwal, Verma and Thakur, 1979b; Roonwal 1983c).

*Soldier* : Either monomorphic (*Glossotermes*) or dimorphic or trimorphic (*Psammotermes*). Head-capsule subsquarish or rectangular, dorso-ventrally flat. Eye-spots present (*Glossotermes*) or absent (*Psammotermes*). Ocelli absent (*Psammotermes*) or rudimentary (*Glossotermes*). Fontanelle minute to fairly prominent; situated a little above middle of head-dorsum. Antennae narrowing distally, with 12-17 segments; 3rd segment subequal to 2 and slightly longer than 4 (*Glossotermes*) and conspicuously larger than 4 (*Psammotermes*). Postclypeus convex, separated from frons by distinct suture; anteriorly straight or convex; not emarginate. Labrum broad, tongue-shaped or pentagonal; apically pointed or broadly rounded. Mandibles wide at base, tapering in front to sharply pointed, slightly hooked tip; inner margin with 5-9 marginal teeth or large number of prominent and variable (small to large) serrations. Pronotum flat, with or without anterior lobes. Legs with femora somewhat swollen; apical tibial spurs 3:2:2 (*Psammotermes*) or 2:2:2 (*Glossotermes*). Abdomen elongate; cerci 2-jointed; styli single-jointed.

*Worker* : Head subrounded; broader than length to base of mandibles. Fontanelle indistinct. Antennae with 14-16 segments. Postclypeus weakly swollen; divided by median suture and a little shorter than half of width. Labrum broadly dome-shaped; anterior margin sometimes slightly projected

medially. Mandibles as in imago. Pronotum flat, narrower than head; anterior margin weakly notched medially. Abdomen elongate; cerci 2-jointed; styli single-jointed.

## 2. *Distribution and Composition of Psammotermitinae*

*Distribution* : Africa (Algeria, Egypt, Eritrea, Sudan, Senegal, South and South West Africa), Madagascar, Arabian Peninsula, South Asia (Pakistan and North-West India) and South America (British Guiana).

*Composition* : The subfamily comprises only two genera as follows :

1. *Psammotermes* Desneux. Africa, Asia.
2. *Glossotermes* Emerson. South America.

### Genus 13. *Psammotermes* Desneux

Genus *Psammotermes* Desneux :

1902. Desneux, *Ann. Soc. Ent. Belg.*, 46(10): 436.
1904. Desneux, In P. Wytman's *Genera Insect.*, Fasc. 25: 24.
1911. Holmgren, *K. Sv. Vet. Akad. Handl.*, 46(6): 62, 65-66, 67, 68.
1921. Fuller, *S. Afr. J. nat. Hist.*, 6(2): 20, 23, 46.
1926. Sjöstedt, *K. Sv. Vet. Akad. Handl.*, (3) 3(1): 45.
1928. Emerson, *Bull. Am. Mus. nat. Hist.*, 57(Art. 7): 406, 423.
1949. Snyder, *Smiths. misc. Colls.*, 112: 64-66.
1950. Emerson, *Am. Mus. Novit.*, No. 1444:4.
1950. Ahmad, *Bull. Am. Mus. nat. Hist.*, 95(Art. 2): 53, 54, 75.
1955. Weidner, In *Die Termiten* (Ed. Schrödt): 54, 69.
1955. Emerson, *Fieldiana: Zool.*, 37: 473, 479, 483, 484, 509.
1961. Harris, *Termites: Their Recognition and Control*: 50. (2nd Edition, 1971).
1962. Roonwal and Bose, *Rec. Indian Mus.*, 58(3 & 4): 151-152.
1962. Roonwal, Chhotani and Bose, In *Termites in Humid Tropics* (Proc. N. Delhi Symps., Oct. 1960): 51-54.
1964. Roonwal and Bose, *Zoologica*, 40(13): 8.
1965. Buillon and Mathot, *Zooleo*, No. 1: 20.
1966. Buillon and Mathot, *Zooleo*, No. 1 (Suppl. 1): 4, 6 and Table.
1970. Krishna, In *Biology of Termites* (Eds. Krishna and Weesner) Vol. 2: 137, 138.

1970. Roonwal, In *Biology of Termites* (Eds. Krishna and Weesner) Vol. 2: 332.
1971. Emerson, *Bull. Am. Mus. nat. Hist.*, 146(Art. 3): 251, 256, 257, 259, 262.
1971. Buillon and Mathot, *Zooleo*, No. 1 (Suppl. 2): 7.
1972. Chaudhry and Ahmad, *Termites of Pakistan* (Final Tech. Rep. PL 480 Proj.): 12.
1973. Coaton and Sheasby, *Cimbebasia*, (4) 3(3): 20.
1973. Chhotani and Bose, *Zool. Anz.*, 190(3/4): 233, 234.
1974. Akhtar, *Pakistan J. Zool.*, 6(1/2): 90, 91, 96, 97, 98, 99, 100.
1975. Emerson, *Am. Mus. Novit.*, No. 2570: 13, 14, 15, 16, 17, 18, 19, 20, 21, 22.
1979. Chhotani and Bose, *Fauna of Saudi Arabia* Vol. 1: 82.
1979. Roonwal, Verma and Thakur, *Proc. Indian natnl. Sci. Acad.*, (B) 45(4): 333-334, 351.
1983. Roonwal, *Proc. Indian natnl. Sci. Acad.*, (B) 49(5): 363, 387.
1983. Chhotani, *Oriental Insects*, 17: 111, 112, 114, 119.
1983. Chhotani and Bose, *Fauna of Saudi Arabia* Vol. 5: 124, 127.
1985. Chhotani, *Z. ang. Ent.*, 100: 91, 92, 93.
1986. Grassé, *Termitologia* Vol. 3: 519.

Type of genus : *Psammotermes hybostoma* Desneux.

### 1. Characters of Genus *Psammotermes*

*Imago* : As in subfamily Psammotermitinae (vide supra).

*Soldier* : Dimorphic or trimorphic. Head-capsule subrectangular, dorso-ventrally flattened; in larger soldier almost squarish. Eyes and ocelli absent. Fontanelle prominent, round, with chitinous border; situated a little above middle of head-dorsum; with a groove running from opening to base of labrum. Antennae narrowing distally; with 12-17 segments, segment 3 conspicuously large. Postclypeus flat with convex posterior margin, clearly differentiated from frons. Labrum subpentagonal with a pointed tip in larger soldier, broadly tongue-shaped in smaller soldier. Mandibles broad basally, tapering in front to a weakly incurved distal tip. Inner margin with 5-9 marginal teeth. Postmentum club-shaped; a little narrowed at waist. Pronotum flat, narrower to almost as wide as head-capsule. Legs with 3:2:2 apical tibial spurs; tarsi 4-jointed. Abdomen elongate; cerci 2-jointed and styli single-jointed.

*Worker* : As in subfamily Psammotermitinae (vide supra).

## 2. Distribution and Composition of *Psammotermes*

**Distribution :** Africa, Madagascar, Arabia, East to Pakistan and N.W. India.

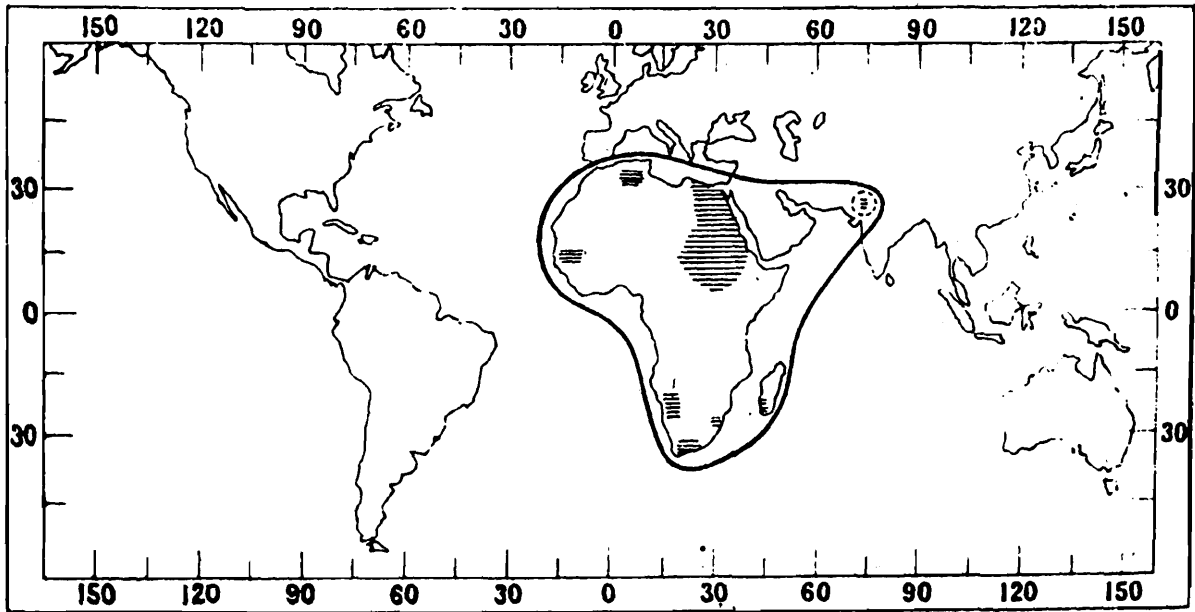

Fig. 218. Map of the world showing distribution of genus *Psammotermes* (After Roonwal, Chhotani and Bose 1962).

**Composition :** The following 4 species are known of which a single one, *P. rajasthanicus*, occurs in the Indian Region (Pakistan and North West-India) :-

1. *Psammotermes allocerus* Silvestri. Southern Africa.
2. *P. hybostoma* Desneux. Northern Africa and Arabia.
3. *P. rajasthanicus* Roonwal and Bose. North-West India and Pakistan.
4. *P. voeltzkowi* Wasmann. Madagascar.

### 60. *Psammotermes rajasthanicus* Roonwal and Bose (Figs. 219-221)

*Psammotermes rajasthanicus* Roonwal and Bose :

1960. Roonwal and Bose, *Sci. & Cult.*, 26(1): 38-39. S,W. Holotype: S, in ZSI. Type-locality: Balana, 20 miles E. of Mohangarh (Dist. Jaisalmer, Rajasthan, India). Type examined.

1962. Roonwal and Bose, *Rec. Indian Mus.*, 58(3 & 4): 152-158, 2 pls. S, W.
1962. Roonwal, Chhotani and Bose, In *Termites in Humid Tropics* (Proc. New Delhi Symp. Oct. 1960): 51-54, 1 pl.
1964. Roonwal and Bose, *Zoologica*, 40(13): 12-14.
1969. Roonwal and Bose, *Rec. Zool. Surv. India*, 61(3-4): 438, 445, pl. 21.
1970. Roonwal, In *Biology of Termites* (Eds. Krishna and Weesner) Vol. 2: 332.
1972. Chaudhry and Ahmad, *Termites of Pakistan* (Final Tech. Rept. PL 480 Proj.): 12.
1974. Akhtar, *Pakistan J. Zool.*, 6(1-2): 90, 101.
1976. Roonwal, *Zool. Jb. (Syst.)*, 103: 464, 465, 466, 468, 482, 483.
1977. Roonwal, In *Natural Resources of Rajasthan* (Ed. Roonwal) Vol. 1: 375, 376, 377; Pl. 3, fig. 6.
1977. Verma and Thakur, *Newsl. zool. Surv. India*, 3(1): 14.
1978. Roonwal and Bose, *Proc. Indian natn. Sci. Acad.*, (B) 44(5): 320, 322.
1986. Grasse, *Termitologia* Vol. 3: 520.
1988. Roonwal, *Indian J. Ent.*, 47(4): 455-460.

**IMAGO : Unknown.**

**SOLDIER** (Figs. 219, 220) : Polymorphic with 3 types, major, medium and minor soldiers. *Soldier Major* (Fig. 219 A & D) : Size large (Total length 7.4-8.2 mm). Head deep yellow, area between fontanelle to clypeus brown; postclypeus, antennal sockets and labrum deep golden brown; mandibles reddish brown, paler basally; body and legs yellowish white. Head fairly and body densely, hairy. Head-capsule subrectangular, flat, longer than broad (length to base of mandibles 1.8-2.00, max. width 1.35-1.50 mm); width 3/4th of length, index Max.width/ Length 0.73-0.76; sides substraight; posterior corners rounded. Fontanelle distinct, rounded; situated a little distal to middle; with a groove running upto base of labrum. Eyes and ocelli absent. Antennae with 14-15 segments; segment 2 shortest; 3 large, twice as long as 2; 4 shorter than 3. Anteclypeus narrow, apilose, hyaline. Postclypeus narrow, faintly demarcated. Mandibles long (1.43-1.80 mm), sabre-shaped, tapering and incurved apically and thick and strong basally. Left mandible with 6-8 and right with 4-6 irregular teeth. Labrum subpentagonal, crown-shaped (median length 0.70-0.93, max. width 0.73-0.95 mm); demarcated into 3 lobes, an apical and 2 lateral ones. Postmentum club-shaped (length 1.25-1.48, max. width 0.53-0.58 mm),

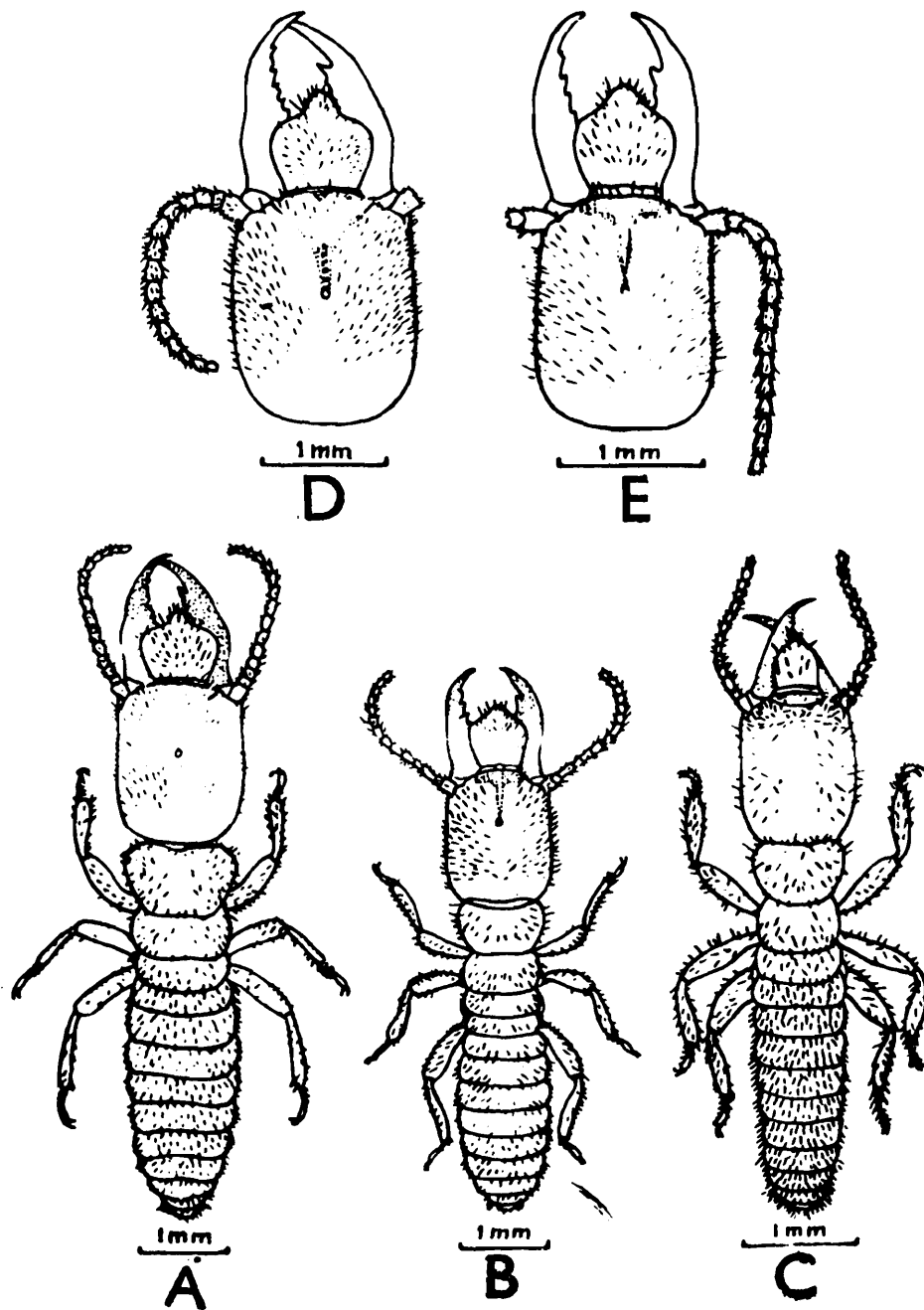

Fig. 219 *Psammotermes rajasthanicus*. Three types of soldiers. (A) Soldier major, in dorsal view. (B) Soldier medium. (C) Soldier minor. (D) Head of soldier major. (E) Head of soldier medium. (From Roonwal 1977).

weakly narrowed at waist (0.35-0.38 mm). Pronotum flat, subtrapezoidal, narrower than head and wider than long (length 0.78-0.95, width 1.13-1.35 mm). Legs rather short and stout; tarsi 4-segmented; apical tibial spurs 3:2:2. Abdomen oblong; cerci 2-jointed; styli single-jointed.

*Soldier Medium* (Fig. 219 B & E) : Resembles soldier major but is smaller in size (Total length 5.9-6.80, head-length to mandible-base 1.50-1.65, max. head-width 1.20-1.25, pronotum-width 0.98-1.10 mm). Antenna as in soldier major, with 14-15 segments. Labrum with little less bulged lateral lobes (length 0.55-0.70, width 0.55-0.70 mm).

*Soldier Minor* (Figs. 219C and 220) : Resembles soldier major and soldier medium but is smaller (Total length 4.00-5.35, head-length to mandible base 1.08-1.40. max. head-width 0.85-1.05 and pronotum-width

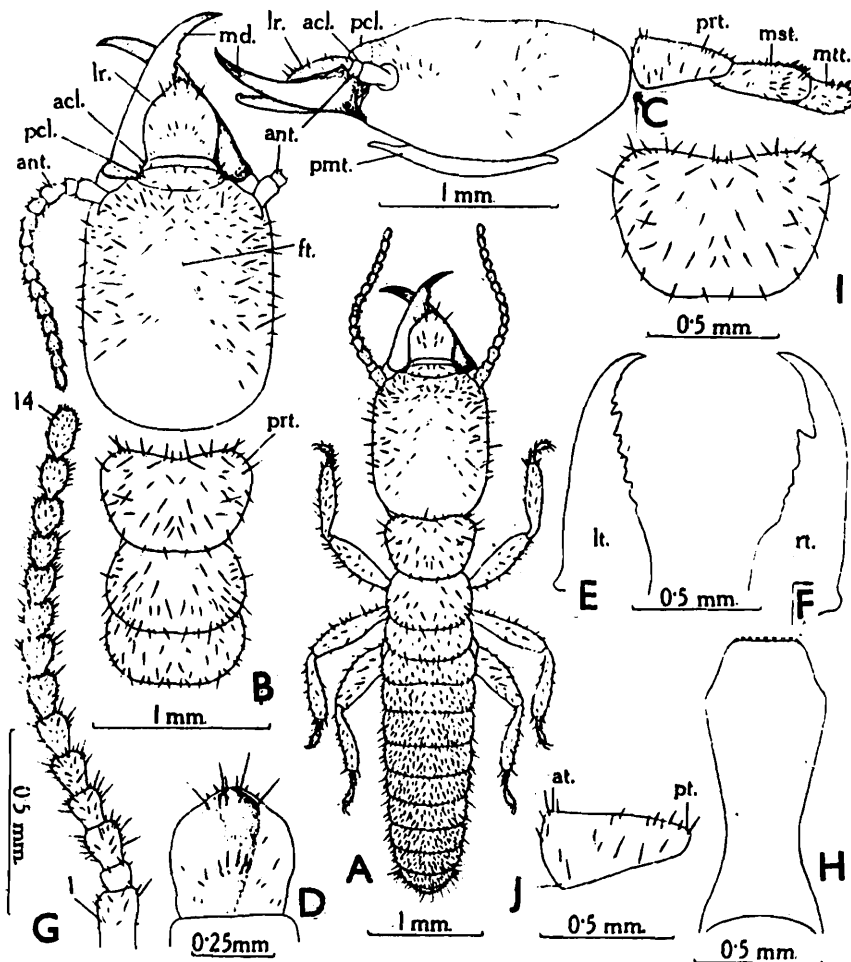

Fig. 220. *Psammotermes rajasthanicus*. Soldier minor. (A) Soldier minor, in dorsal view. (B) Same, head and thorax enlarged. (C) Same, in lateral view. (D) Labrum. (E) Left mandible. (F) Right mandible. (G) Left antenna. (H) Postmentum. (I) Pronotum, in dorsal view. (J) Same, in side view. acl., anteclypeus; ant., antenna; at., anterior; ft., fontanelle; lt., left; lr., labrum; md., mandible; mst., mesonotum; mtt., metanotum; pcl., postclypeus; prt., pronotum; pt., posterior; rt., right. (After Roonwal and Bose 1962).

0.63-0.83 mm). Antennae as in soldiers major and medium; with 14-15 segments. Labrum tongue-shaped and not crown-shaped as in soldiers major and medium (length 0.30-0.43, width 0.30-0.43 mm).

**WORKER** (Fig. 221) : Head pale yellow; antennae whitish, apically pale yellowish white; thorax and body white. Head and body fairly densely hairy, Total body-length c 3.30-3.90 mm. Head-capsule rounded; broader than length to base of mandibles (length 0.80-0.88, width 0.93-1.03 mm). Fontanelle indistinct. Eyes and ocelli absent. Antennae with 14 segments; 4th segment smallest. Postclypeus swollen, hairy; anteclypeus hyaline, apilose, flat. Labrum dome-shaped; broader than long. Mandibles as in genus. Pronotum flat, subtrapezoidal (length 0.30-0.40, width 0.53-0.63 mm); anterior margin with a median notch; posterior margin straight. Legs and abdomen as in soldier.

*Distribution* : North-western India and Pakistan, mostly in the arid areas, as follows :-

**INDIA** : Arid districts of Rajasthan (western India) e.g., Barmer District (Pachpadra and Tamlone village near Gadra Road railway station), Jaisalmer District (Nokh, Mohangarh, Ramgarh and Balana, the last-one being the type-locality), Jodhpur District (east to Jodhpur and vicinity) and Bikaner District (Pugal).

**PAKISTAN** : All over southern and western Pakistan e.g., southern Baluchistan west to Gawadar (Mekran coast), Sind and Panjab north to Lyallpur (Faizlabad). [Details : Gawadar, Uthal (Las Bela), Karachi, Mirpurkhas, Rohri, Sukkur, Khanpur, 'Merrot (Cholistan)', Lyallpur. 'Merrot' is the same as Merrot in Bahawalpur District, lat. 29°10' N, long 72°25' E) (Roonwal 1980).

*Biology* : It prefers arid, low-rainfall areas and is common under stones in sandy soil. It also attacks saplings in nurseries as well as larger trees. It also damages woodwork in huts and houses. Nesting occurs under-ground. Among the polymorphic soldiers, the minor soldiers are the most common (about 70 per cent), the other two types being rarer. (Chaudhry and Ahmad, 1972, Parihar 1978-1981, Roonwal and Bose 1978, Roonwal 1970a, 1976, 1988).

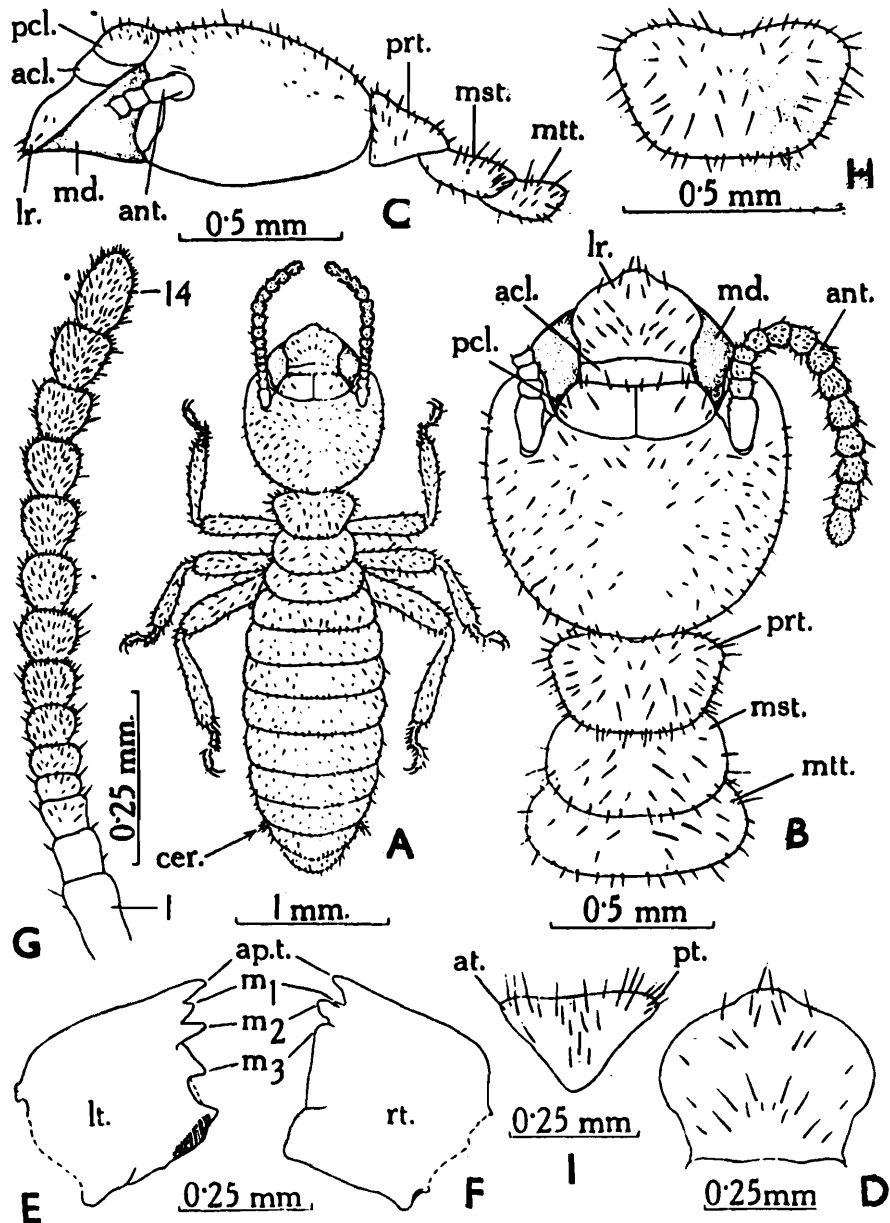

Fig. 221. *Psammotermes rajasthanicus*. Worker. (A) Worker, in dorsal view. (B) Same, head and thorax, enlarged. (C) Same, in side view. (D) Labrum. (E) Left mandible. (F) Right mandible. (G) Left antenna. (H) Pronotum, in dorsal view. (I) Same, in side view.

acl., anteclypeus., ant., antenna; ap.t., apical tooth; at., anterior; cer., cerci; lr., labrum; lt., left., md., mandible; m<sub>1</sub>, m<sub>2</sub>, m<sub>3</sub>, mandibular teeth (1st, 2nd and 3rd); mst., mesonotum; mtt., metanotum; pcl., postclypeus., prt., pronotum; pt., posterior. (After Roonwal and Bose 1962)

### Subfamily (ii) COPTOTERMITINAE Holmgren

Subfamily Coptotermitinae Holmgren :

1911. Holmgren, K. *Sv. Vet. Akad. Handl.*, 46(6): 62, 63, 71.
1913. Holmgren, K. *Sv. Vet. Akad. Handl.*, 50(2): 13-14, 66-78.
1926. Sjöstedt, K. *Sv. Vet. Akad. Handl.*, (3) 3(1): 8, 55.
1949. Snyder, *Smiths. misc. Colls.*, 112: 75.
1950. Ahmad, *Bull. Am. Mus. nat. Hist.*, 95(Art. 2) : 53, 56.
1955. Weidner, In *Die Termiten* (Ed. Schmidt) : 10, 40, 54-55.
1961. Harris, *Termites: Recognition & Control*: 38, 46.
1962. Roonwal and Chhotani, *Indian Species Termite Genus Coptotermes* (ICAR Ent. Monogr. 2) : 3.
1965. Bouillon and Mathot, *Zooleo*, No. 1: 20.
1970. Krishna, In *Biology of Termites* (Eds. Krishna and Weesner) Vol. 2: 131, 137, 138.
1970. Roonwal, In *Biology of Termites* (Eds. Krishna and Weesner) Vol. 2: 336.
1971. Emerson, *Bull. Am. Mus. nat. Hist.*, 146(Art. 3): 248, 265.
1977. Roonwal, *Proc. zool. Soc.*, 28: 35.
1977. Chhotani, *Occ. Pap. Rec. zool. Surv. India*, No. 9: 4, 5.
1977. Chhotani, *VIII int Congr. Int. Un. Stud. Soc. Ins.* (Wageningen, Sept. 1977): 116, 117.
1979. Roonwal, Verma and Thakur, *Proc. Indian natnl. Sci. Acad.*, (B) 45(4): 340-347.
1982. Grassé, *Termitologia* Vol. 1: 92-93.
1983. Roonwal, *Proc. Indian natnl. Sci. Acad.*, (B) 49(5): 363, 367, 377, 379, 387.
1983. Chhotani, *Orient. Insects*, 17: 112.
1984. Bose, *Occ. Pap. Rec. zool. Surv. India*, No. 49: 77, 78.
1985. Chhotani, *Z. ang. Ent.*, 100: 91, 92, 94.
1985. Roonwal, *Proc. Indian natnl. Sci. Acad.*, (B) 51(2): 152.
1986. Grassé, *Termitologia* Vol. 3: 469, 494, 495, 523.

Type genus : *Coptotermes* Wasmann.

#### 1. Characters of Subfamily Coptotermitinae

**Imago** : Generally brown to dark brown, medium size insects. Head subcircular. Eyes of medium size. Ocelli present, generally touching eyes or

slightly separated. Fontanelle minute, situated on mid-dorsum of head. Mandibles, each with an apical and three marginal teeth. Left mandible with 1st marginal a little smaller than the subequal apical and marginals 2nd and 3rd. Right mandible with the 1st marginal greatly reduced and situated at anterior base of 2nd marginal, the latter almost as large as its corresponding one in left mandible; 3rd short with a long posterior margin which is longer than molar plate. Postclypeus flat or weakly swollen. Antennae with 16-23 segments. Pronotum flat; anterior margin slightly incurved, without distinct notch; posterior margin convex, with medial notch. Legs thin and long; apical tibial spurs 3:2:2 (not 3:3:3 as mentioned by some authors); tarsi 4-jointed. Wings generally densely hairy, sometimes slightly hairy; all veins arising independently from scale. Costa (C.) and subcosta (Sc.) fused, thick, strongly sclerotised, running along anterior margin. Radius (R.) (radial sector of some authors) also well chitinised and running parallel to and close to costa-subcosta. Media (M.) thin, weak and with 1-3 branches distally. Cubitus (Cu.) also weak and with 6-13 branches to posterior margin. Hindwing as in forewing except M. arising from radius just outside the scale. Wings densely covered on both surfaces with microsculpturing which may consist of papillae, pimpules and micrasters, but pimpules and micrasters sometimes absent (vide Note infra). Abdomen with 2 jointed cerci in both sexes and single-jointed styli in males.

*Note on wing microsculpturing* : Wing microsculpturing in the Coptotermitinae has been studied by Roonwal (1977a), Roonwal and Rathore (1982), Roonwal, Verma and Thakur (1979b) and Roonwal (1983c), specially the last two. Microsculpturing consists of 3 elements namely papillae, pimpules and micrasters on both wing surfaces, but all are not always present in the same species. Although the subfamily is very compact with a single genus *Coptotermes*, it is divisible, on the basis of sculpturing, into two groups : (A) Sculpturing consisting of only papillae and pimpules; micrasters absent. (B) Micrasters present in addition to papillae; pimpules present or absent. A dense covering of longish hairs (40-135  $\mu\text{m}$ ), in considerable density (c 1145-2290/ $\text{mm}^2$ ) is present in most species; density may be low in few species (*michaelseni* 125/ $\text{mm}^2$ ).

*Soldier* : Head-capsule pyriform to broadly oval. Eyes generally absent, eye spots rarely present. Ocelli absent. Fontanelle prominent, large, with

oval to round opening; situated medially at base of clypeus. Mandibles sabre-shaped and incurved distally. Left mandible with a few (upto 4) crenulations in basal half and a large, knob-like, basal projection. Right mandible with a few crenulations in basal broader portion. Clypeus divided into an ante- and a postclypeus. Antennae with 13-17 segments. Postmentum long, club-shaped. Pronotum generally, flat, sometimes slightly raised anteriorly. Legs thin, with 3:2:2 apical tibial spurs (not 3:3:3); tarsi 4-jointed. Abdomen oblong; cerci 2-jointed; styli single-jointed.

*Worker* : Head subcircular. Fontanelle, eyes and ocelli absent. Mandibles and postclypeus as in imago. Antennae with 12-15 segments. Pronotum usually flat, sometimes upturned at anterior margin. Legs and abdomen as in soldier.

## 2. *Distribution and Composition of Coptotermitinae*

*Distribution* : This subfamily is distributed over all the tropical parts of the world. Many of the species of the only genus *Coptotermes* have got spread to far off places from their original homes and got established as pests of agriculture, plantations and woodwork in houses and buildings. Their habit of nesting in wood and woodwork has helped their spread.

*Composition* : This subfamily comprises only one genus viz., *Coptotermes* Wasmann.

### Genus 14. *Coptotermes* Wasmann (syn. *Arrhinotermes* Wasmann)

1. Subgenus *Coptotermes* (of genus *Termes* Linn.) Wasmann :

1896. Wasmann, *Ann. Mus. Civ. Stor. Nat. Genova*, 16(36): 629.

1897. Wasmann, *Abhandl. Senckenb. Naturf. Ges.*, 21(1): 151.

1904. Desneux, In P. Wytman's *Genera Insectorum*, Fasc. 25: 29, 32.

2. Genus *Coptotermes* Wasmann :

1898. Haviland, *J. Linn. Soc. Lond. (Zool.)*, 26(169): 390.

1903. Silvestri, *Redia*, 1: 46.

1909. Holmgren, *K. Sv. Vet. Akad. Handl.*, 44(3): 28, 110, 169.

1911. Holmgren, *K. Sv. Vet. Akad. Handl.*, 46(6): 73.

1913. Holmgren, K. *Sv. Vet. Akad. Handl.*, 50(2): 71.
1942. Hill, *Termites Isoptera Austr. Region*: 140-141.
1949. Snyder, *Smiths. misc. Coll.*, 112: 75.
1955. Weidner, In *Die Termiten* (Ed. Schmidt) : 54-55.
1955. Ahmad, *Biologia*, Lahore, 1(1): 212, 213.
1958. Ahmad, *Biologia*, Lahore, 4(1-2): 59, 60-68.
1961. Harris, *Termites : Recognition & Control*: 6-7, 46-47.
1962. Roonwal and Chhotani, *Indian Species Termite Genus Coptotermes* (ICAR Ent. Monogr. 2) : 3-9.
1962. Roonwal and Chhotani, *Proc. natnl. Inst. Sci. India*, (B) 28(4): 294, 295, 306.
1965. Bouillon and Mathot, *Zooleo*, No. 1: 20.
1965. Ahmad, *Bull. Am. Mus. nat. Hist.*, 131(Art. 1): 7, 8, 17.
1970. Krishna, In *Biology of Termites* (Eds. Krishna and Weesner) Vol. 2: 137-138.
1970. Roonwal, In *Biology of Termites* Vol. 2: 336-339.
1971. Emerson, *Bull. Am. Mus. nat. Hist.*, 146 (Art. 3): 248, 251, 256, 257, 258, 260, 265-268, 298.
1977. Chhotani, *VIII int. Congr. Int. Un. Study Social Insects* (Wageningen Sept., 1977): 116.
1979. Roonwal, Verma and Thakur, *Proc. Indian natnl. Sci. Acad.*, (B) 45(4): 340-347.
1979. Sen-Sarma and Thakur, *Indian For. Rec. Ent. (N.S.)*, 13(1): 4, 5.
1982. Thapa, *Sabah For. Rec.*, No. 12: 4, 5, 74.
1983. Roonwal, *Proc. Indian natnl. Sci. Acad.*, (B) 49(5): 364, 379, 387.
1983. Chhotani, *Orient. Insects*, 17: 111, 112.
1983. Maiti, *Occ. Pap. Rec. zool. Surv. India*, No. 42: 17, 22.
1984. Bose, *Occ. Pap. Rec. zool. Surv. India*, No. 49: 71 (fig. 54), 78, 81, 82.
1985. Chhotani, *Z. ang. Ent.*, 100: 91.
1986. Grassé, *Termitologia*, Vol. 3: 523.

### 3. Genus *Arrhinotermes* Wasmann:

1902. Wasmann, *Zool. Jb. (Syst.)*, 17(1): 103-104, 139, 160. (Wasmann did not designate the type of genus. But as the genus was originally described for *A. heimi* nov., and *A. oceanicus* was added only later on in the same paper as an Appendix, the former species should, on the basis of page priority, be regarded as the type of genus. Furthermore, the second species, *A. oceanicus* does not belong to genus *Arrhinotermes* Wasmann at all but to *Prorhinotermes* Silvestri described later (vide Roonwal and Chhotani, 1962, p. 3).

4. Subgenus *Arrhinotermes* (of genus *Termes* Linn.) Wasmann :  
1904. Desneux, In P. Wytman's *Gen. Insect.*, Fasc. 25: 31.

Type of genus : *Termes (Coptotermes) gestroi* Wasmann.

### 1. Characters of Genus *Coptotermes*

Same as in subfamily Coptotermitinae, supra.

### 2. Distribution and Composition of *Coptotermes*

*Distribution* : Same as in subfamily Coptotermitinae, supra.

*Composition* : About 50 species of the genus *Coptotermes* are known. Of these, the following nine occur in the Indian Region:

1. *Coptotermes beckeri* Mathur and Chhotani. India.
2. *C. ceylonicus* Holmgren. Sri Lanka, India.
3. *C. emersoni* Ahmad. Sri Lanka.
4. *C. formosanus* Shiraki. Pakistan and Sri Lanka, introduced. Taiwan, China, Japan. Also introduced to S. Africa, Southern U.S.A., Brazil and the Hawaii Islands.
5. *C. gaurii* Roonwal and Krishna. Sri Lanka.
6. *C. gestroi* (Wasmann). India (NE part), Burma and Thailand.
7. *C. heimi* (Wasmann) (Syn. *C. parvulus* Holmgren). India, Pakistan, Bhutan and Bangladesh. Oman (Arabia), introduced.
8. *C. kishori* Roonwal and Chhotani. India.
9. *C. travians* (Haviland). India, Bangladesh, Burma, Malaysia and Indonesia.

### 3. Keys to Indian Region Species of *Coptotermes*

#### IMAGOES

Out of 9 species known from the Indian Region, imagoes are known only in 4 which are included in the key given below.

- 1(2) Larger species: Head-width 1.53-1.65 mm; maximum diameter of eye with ocular sclerite 0.43-0.45 mm; total length with wings 14-16 mm; length of forewing 11-12 mm ..... *formosanus*
- 2(1) Smaller species : Head-width 1.18-1.53 mm; maximum diameter of eye with ocular sclerite 0.37-0.43 mm; total length with wings 10.6-14.0 mm; length of forewing 8.5-10.0 mm
- 3(4) Head-width c 1.18-1.45 mm; pronotum smaller (length 0.61-0.83 mm, width 1.06-1.38 mm)..... *travians*
- 4(3) Head-width 1.30-1.53 mm; pronotum larger (length 0.72-0.93 mm; width 1.10-1.44 mm)
- 5(6) Ocellus smaller (maximum diameter 0.14-0.15 mm); minimum ocellus-antennal distance greater, 0.09-0.13 mm. Antennae with 19-23 segments; segments 3-7 broader than long; 8 almost round ..... *ceylonicus*
- 6(5) Ocellus larger (maximum diameter 0.16-0.19 mm); minimum ocellus-antennal distance smaller, 0.08 mm. Antennae with 20-22 segments, segments 3-9 (or 10) broader than long; 10 or 11 almost round ..... *heimi*

## SOLDIERS

- 1(8) Waist of postmentum lying definitely below middle of line connecting the level of maximum width and the hind margin
- 2(3) Mandibles long in relation to head-length (mandible-head-length index, i.e., Mandible-length/Head-length to base of mandibles, 0.71). Waist of postmentum very narrow (contraction index, i.e., Minimum width/Maximum width c 0.51)..... *emersoni*
- 3(2) Mandibles small in relation to head-length (mandible-head-length index 0.58-0.71, generally less than 0.71). Waist of postmentum wide (contraction index 0.55-0.89).
- 4(5) Mandibles shorter (length 0.57-0.63 mm). Waist of postmentum very wide (contraction index 0.75-0.89) ..... *gaurii*
- 5(4) Mandibles longer (length 0.73-0.80 mm). Waist of postmentum less wide (contraction index 0.55-0.66)
- 6(7) Head longer (1.13-1.25 mm long), wider (0.95-1.08 mm wide) and more convergent anteriorly (convergence index i.e., Width at anterior end/Max. width 0.57-0.63). Pronotum broader (0.65-0.73 mm wide) ..... *kishori*
- 7(6) Head shorter (1.10-1.13 mm long), narrower (0.90-0.98 mm wide) and less convergent anteriorly (convergence index 0.62-0.66). Pronotum narrower (0.58-0.63 mm wide) ..... *beckeri*

- 8(1) Waist of postmentum lying in middle of line connecting the level of maximum width and the hind margin
- 9(12) Dorsum of head behind fontanelle neither swollen nor wavy; head-length to base of mandibles 1.40-1.65 mm
- 10(11) Generally less hairy. Head with one hair on either side of fontanelle. Mandibles small (length 0.90-0.93 mm); mandible head-length index 0.60. Sides of postmentum at extreme anterior end (anterior to its broadest part) concave in middle ..... *gestroi*
- 11(10) Generally more hairy. Head with two hairs on either side of fontanelle. Mandibles long (length 0.95-1.03 mm); mandibles-head-length index 0.61-0.65. Sides of postmentum anterior to broadest region, straight ..... *formosanus*
- 12(9) Dorsum of head behind fontanelle swollen and wavy; head-length 1.14-1.50 mm
- 13(14) Postmentum : Minimum width smaller (0.20-0.29 mm); contraction index 0.57-0.69 ..... *ceylonicus/travians*
- 14(13) Postmentum : Minimum width greater (0.25-0.34 mm); contraction index 0.63-0.76 ..... *heimi*

### 61. *Coptotermes beckeri* Mathur and Chhotani (Figs. 222, 223)

*Coptotermes beckeri* Mathur and Chhotani :

1969. Mathur and Chhotani, *J. Timber Dev. Assoc. India*, 15(4): 1-5. S&W. Holotype: S, in FRI., Dehra Dun. Type-locality : Madras, India.

1983. Chhotani, *Orient. Insects*, 17: 117.

1984. Bose, *Occ. Pap. Rec. zool. Surv. India*, No. 49: 82-83.

IMAGO : Unknown.

**SOLDIER** (Fig. 222) : Head-capsule pale yellow; antennae, labrum, pronotum, legs and body paler; mandibles dark brown. Head with a few hairs and with one small hair on either side of fontanelle; pronotum with a few long hairs on anterior margin and smaller-ones on margins and on body; abdomen pilose. Total length 3.50-4.00 mm. Head-capsule suboval, with sides narrowing anteriorly; longer than broad (length to base of mandibles 1.10-1.13, width 0.90-0.98 mm); broadest in posterior one-fourth, posterior margin convex; dorsum wavy in profile due to slight depression in middle.

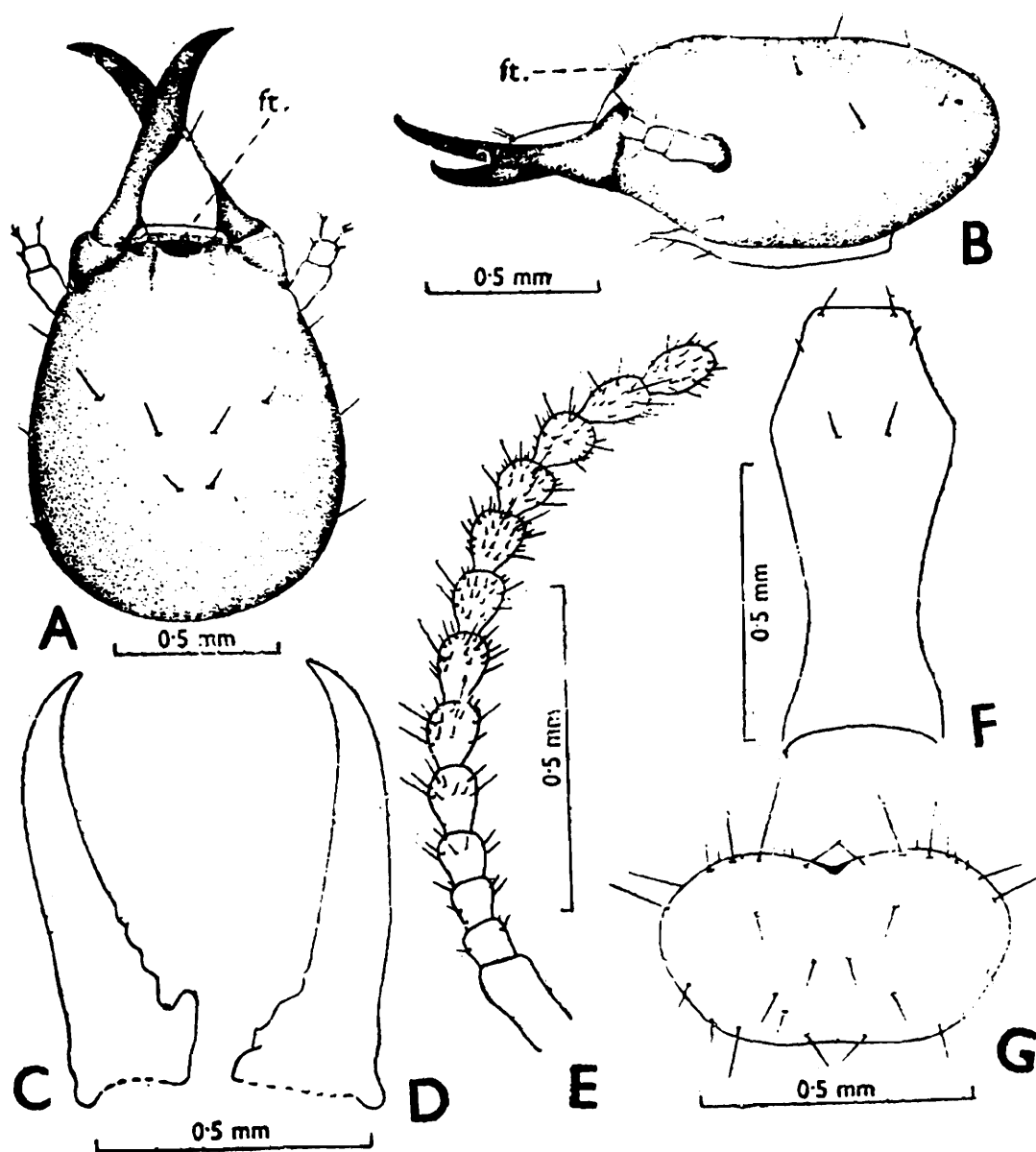

Fig. 222. *Coptotermes beckeri*. Soldier. (A) Head, in dorsal view. (B) Same, in side view. (C) Left mandible. (D) Right mandible. (E) Left antenna. (F) Postmentum. (G) Pronotum. ft., fontanelle. (After Mathur and Chhotani, 1969).

Fontanelle prominent, subcircular; with chitinoid margin. Eyes and ocelli absent. Antennae with 13 segments; segment 2 subsquarish; 3 variable in size; from 4 gradually increasing in size to 7th, rest subequal. Labrum subtriangular, longer than broad (length 0.28-0.30, width 0.23 mm); widest at about middle, converging anteriorly to a hyaline, pointed apex having 2

long bristles at base of hyaline portion. Mandibles sabre-shaped (0.73-0.78 mm long) and slightly incurved at apices. Left mandible with four crenulations and a basal projection. Right mandible with three crenulations in basal-third of inner margin. Postmentum club-shaped, long (length 0.75-0.83 mm); broadest in anterior one-third (0.35-0.38 mm), from whence sides converging to a narrow waist at basal one-fourth (waist-width 0.20-0.21 mm) and again widening out slightly to a concave posterior margin; a very few hairs present on anterior margin and on body. Pronotum subreniform, flat, much broader than long (width 0.58-0.63, length 0.33-0.36 mm); anterior margin convexical and medially notched; sides rounded; posterior margin substraight, with weak, medial depression. Legs long, slender; tibial spurs 3:2:2; tarsi 4-jointed. Abdomen oval; cerci 2-segmented; styli one-segmented.

**WORKER** (Fig. 223) : Head-capsule pale yellowish; antennae, thorax and abdomen yellowish white. Head and abdomen sparsely, irregularly pilose; pronotum hairy along margins and on body. Total length 2.90 mm.

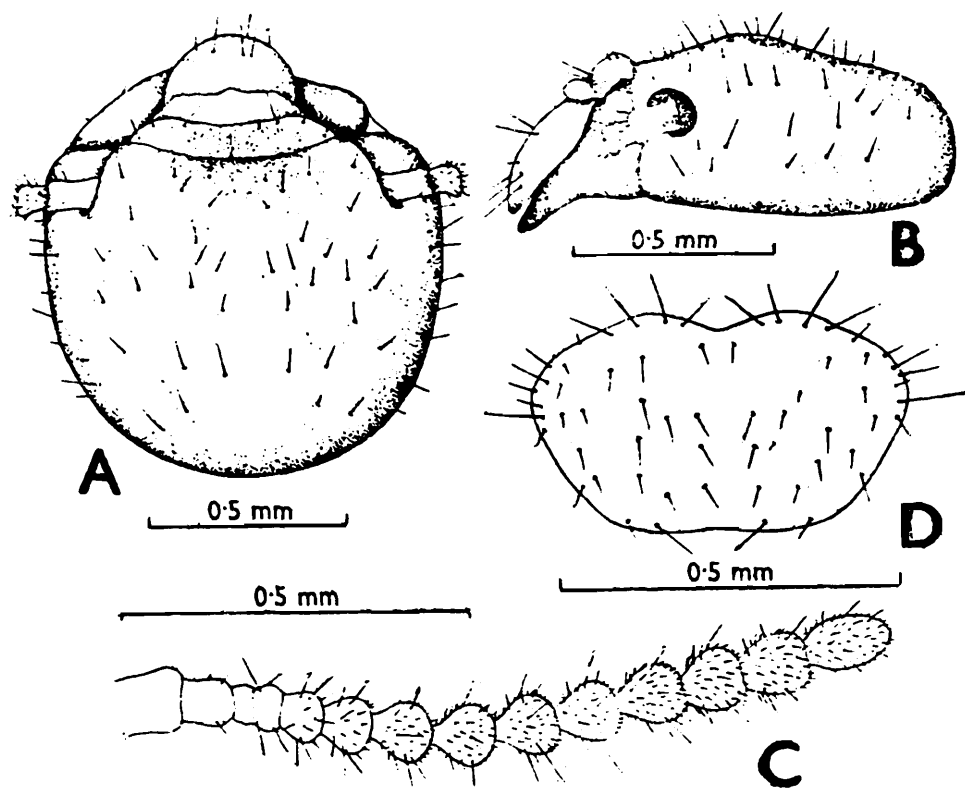

Fig. 223. *Coptotermes beckeri* Worker. (A) Head, in dorsal view. (B) Same, in side view. (C) Left antenna. (D) Pronotum. (After Mathur and Chhotani, 1969).

Head-capsule subrounded, a little broader than long (width 0.95, length to base of mandibles 0.88 mm); dorsum swollen, frontal areas slightly depressed. Fontanelle, eyes and ocelli absent. Antennae with 13 segments; segment 2 slightly longer than that of soldier; 3 incompletely divided. Postclypeus pale yellow, with a few hairs and slightly swollen; anteclypeus whitish, trapezoidal, apilose. Labrum broader than long (width 0.55, length 0.30 mm). Pronotum subreniform; anterior margin weakly upturned, convex and deeply notched medially; posterior margin substraight, weakly incurved in middle. Legs and abdomen as in soldier.

*Distribution* : INDIA : Madras (Tamil Nadu), type-locality.

## 62. *Coptotermes ceylonicus* Holmgren (Figs. 224-226)

### 1. *Coptotermes ceylonicus* Holmgren :

1911. Holmgren, In Escherich's *Termitenleben auf Ceylon*: 192-193, 206, 210; Pl. 3, fig. D (S.). Im and S. Holotype : Not designated. Syntypes in Vienna Mus.; AMNH, New York; FRI, Dehra Dun; Holmgren Coll., National Mus., Stockholm; Silvestri Coll., Naples, Italy. Type-localities Sri Lanka: Seenigoda Estate; Peradeniya; Heneratgoda.
1913. Holmgren, *K. Sv. Vet. Akad. Handl.*, 50(2): 75-76, Pl. 2, fig. 9(S.). Im, S. W.
1925. John, *Treubia*, 6(3-4): 381.
1926. Kemner, *Bull. ent. Res.*, 16(4): 384. S, W.
1927. Bathelier, *Faun. Colon. Fr.*, Paris, 1: 134-135, 185-186. Im, S, W.
1934. Margabandhu, *J. Bombay nat. Hist. Soc.*, 37(3): 703.
1949. Snyder, *Smiths. misc. Colls.*, 112: 76.
1953. Rattan Lal and Menon, *Catal. Indian Insects, Pt. 27, Isoptera* : 24-25.
1958. Ahmad, *Biologia*, Lahore, 4(1-2): 62, 64.
1961. Harris, *Termites : Recognition & Control* : 81, 85, 86, 99, 100, 107, 150.
1962. Roonwal and Chhotani, *Indian Species Termite Genus Coptotermes* (ICAR Ent. Monogr. 2) : 9-17, 72-73, 80-83 (Pls. 1 & 2). Im, S, W. (Detailed synonymy, descriptions, etc.)
1962. Fernando, In *Termites in Humid Tropics* (Proc. New Delhi Symp., 1960): 205, 208.
1967. Roonwal and Chhotani, *J. Bombay nat. Hist. Soc.*, 63(2): 358.
1970. Roonwal, In *Biology of Termites* (Eds. Krishna and Weesner) Vol. 2: 336.

1980. Chhotani, *Tech. Monogr. Zool. Surv. India*, No. 4: 29-31.
1983. Chhotani, *Orient. Insects*, 17: 114, 117.
1984. Bose, *Occ. Pap. Rec. zool. Surv. India*, No. 49: 71, 81, 82, 84-85.
1985. Verma, *Indian J. For.*, 8(3): 177.
1986. Grassé, *Termitologia* Vol. 3: 119.
2. *Coptotermes ceylonicus* Holmgren (part) :
1953. Roonwal and Pant, *Indian For. Leaflet (Ent.)*, No. 121(3): 47.
3. *Coptotermes travians* (Haviland) (wrong determination):
1910. Bugnion and Popoff, *Mem. Soc. Zool. Fr.*, 23(5): 107, 115.

Also vide Roonwal and Chhotani (1962b) for detailed synonymy.

**IMAGO** (Figs. 224, 225) : Head-capsule dark brown, fontanelle area paler; labrum, antennae, postclypeus and mandibles yellowish; mandibular teeth and outer margins of mandibles and pronotum dark brown; anteclypeus whitish; wings hyaline; abdominal tergites brown. Head fairly and pronotum thickly pilose; wings and abdomen densely pilose. Total length with wings 10.3 - 14.00, without wings 6.0 - 7.4 mm. Head-capsule subcircular, a little broader than long (width with eyes 1.30 - 1.53, length to mandible-base 1.00 - 1.08 mm); dorsum of head swollen in between ocelli, depressed in fontanelle region; sides and posterior margin convex. Fontanelle minute, situated at about middle of head. Eyes subcircular, medium sized, maximum diameter 0.38 - 0.43 mm. Ocelli whitish, oval, maximum diameter 0.14 - 0.15; situated either very close to or touching eyes; eye-ocellus distance (where not touching eyes) 0.012 - 0.038 mm. Antennae with 19-23 segments; segment 2 longer than 3, the latter shortest; from 4 increasing in size. Postclypeus yellowish, with a very few hairs, subdivided into right and left halves. Anteclypeus apilose, trapezoidal. Labrum broader than long (width 0.43 - 0.48, length 0.33 - 0.4 mm); with a few hairs on body and on rounded anterior margin. Mandibles as in genus. Pronotum flat, subreniform, much broader than long (width 1.10 - 1.44, length 0.68 - 0.85 mm); narrower than head with eyes; anterior margin weakly concave; sides curving to a broadly rounded, medially notched posterior margin. Legs with femora long, tibiae long and slender; apical tibial spurs 3:2:2; tarsi 4-jointed. Wings with scales and anterior veins brownish; membrane transparent hyaline with faint yellowish tinge. Venation as in genus.

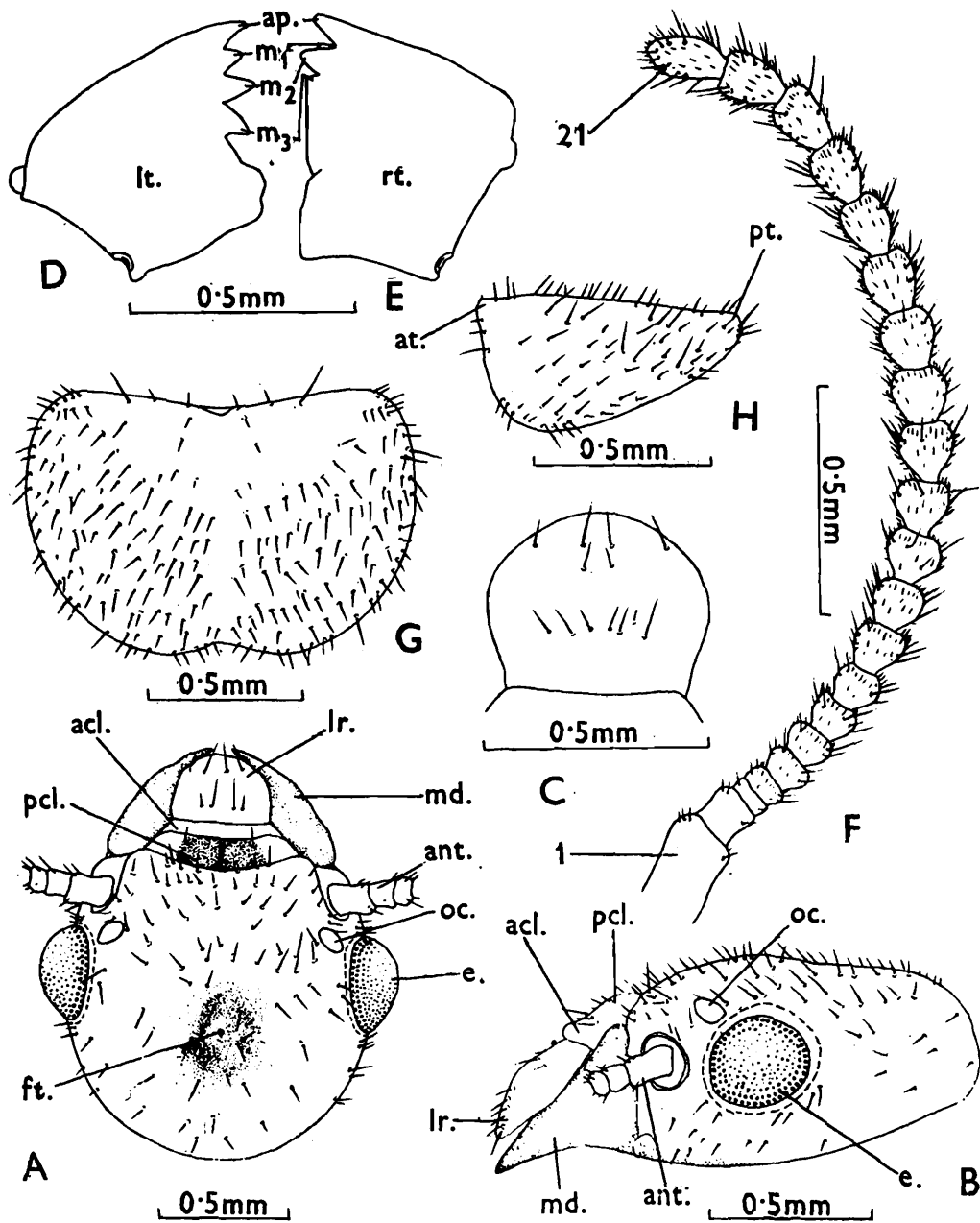

Fig. 224. *Coptotermes ceylonicus*. Imago. (A) Head, in dorsal view. (B) Same, in side view. (C) Labrum. (D) Left mandible. (E) Right mandible. (F) Right antenna. (G) Pronotum, in dorsal view. (H) Same in side view.

acl., anteclypeus; ant., antenna; ap., apical tooth of mandibles; at., anterior; e., eye; ft., fontanelle; lr., labrum; lt., left; m<sub>1</sub>-m<sub>3</sub>, first to third marginal teeth of mandibles; md., mandible; oc., ocellus; pcl., postclypeus; pt., posterior; rt., right (After Roonwal and Chhotani, 1962b).

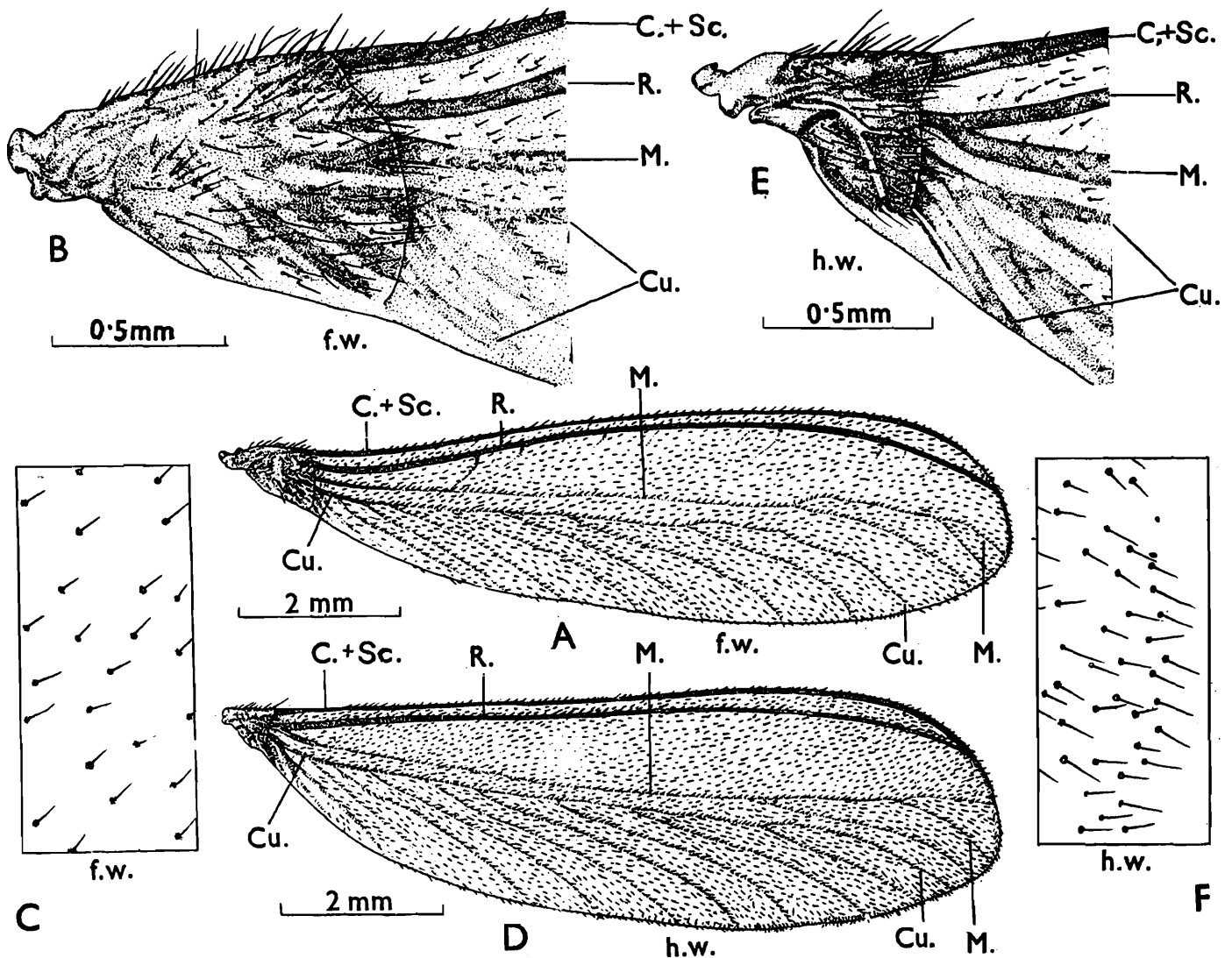

Fig. 225. *Coptotermes ceylonicus*. Wings: (A) Left forewing. (B) Same, scale and proximal part, enlarged. (C) Same, portion from middle, showing hairs. (D) Left hindwing. (E) Same, scale and proximal part, enlarged. (F) Same, portion from middle, showing hairs.

C + Sc., costa - subcosta; Cu., cubitus; f.w., forewing; h.w., hindwing; M., media; R., radius (After Roonwal and Chhotani, 1962b).

Forewing : 8.5-10.7 mm long; cubitus with 8-13 branches. Hindwing : 8.0-10.2 mm long; cubitus 9-12 branched. Abdomen elongate; styli one-jointed; cerci 2-jointed.

**SOLDIER** (Fig. 226): Head-capsule straw-coloured to yellow, fontanelle region paler; mandibles dark brown, rest of body pale. Head with a few erect bristles and with one bristle on either side of fontanelle; pronotum with

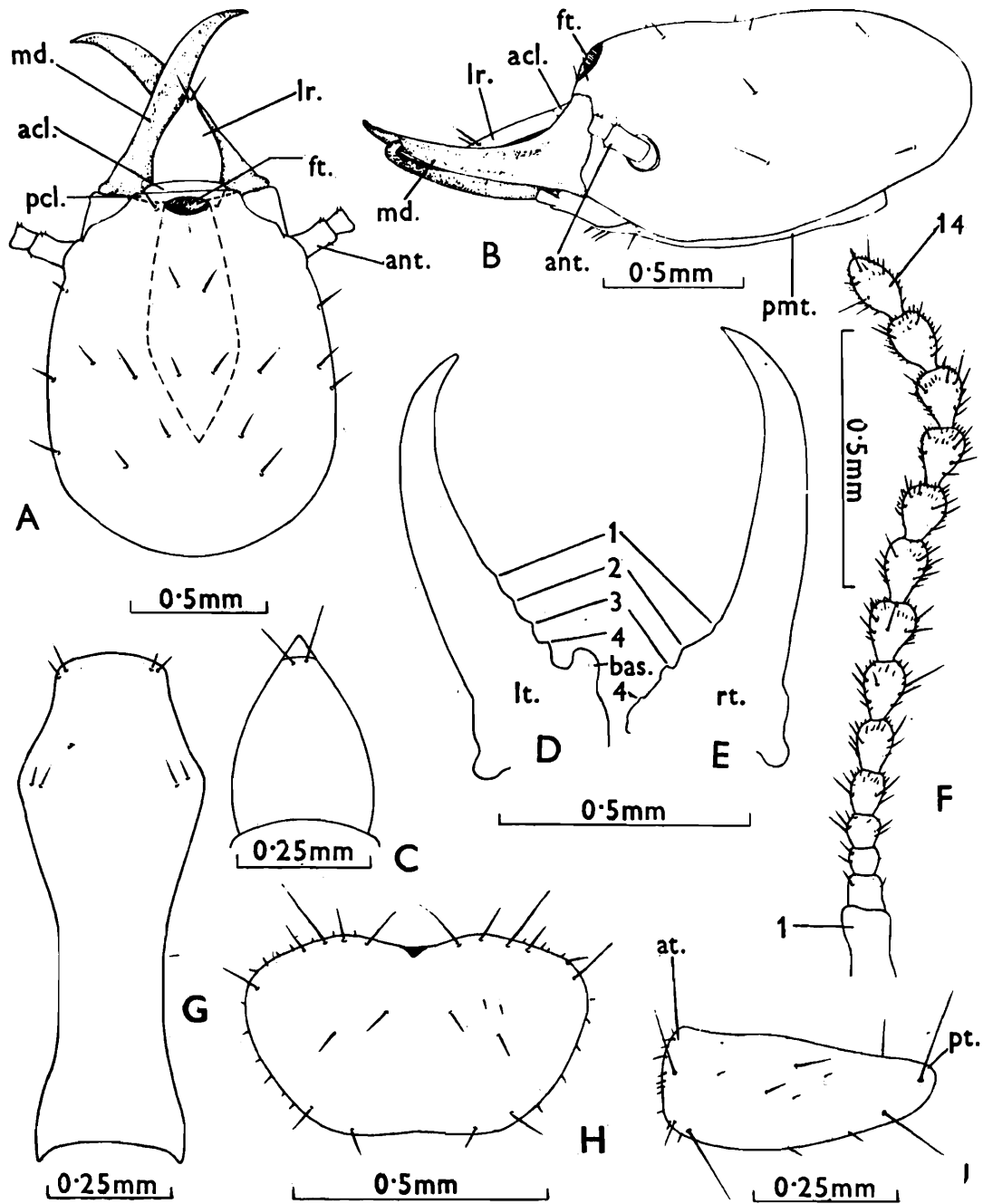

Fig. 226. *Coptotermes ceylonicus*. Soldier. (A) Head, in dorsal view. (B) Same, in side view. (C) Labrum. (D) Left mandible. (E) Right mandible. (F) Right antenna. (G) Postmentum. (H) Pronotum, in dorsal view. (I) Same, in side view. acl., antcelypeus; ant., antenna; at., anterior; bas., basal projection of left mandible; ft., fontanelle; lr., labrum; lt., left; md., mandible; pcl., postclypeus; pmt., postmentum; pt., posterior; rt., right. (After Roonwal and Chhotani, 1962b).

a few small hairs on anterior margin and longer ones on body. Abdomen with a row of hairs on posterior margins of terga and some scattered ones on body. Total length 4.0 - 5.8 mm. Head-capsule oval, longer than broad (length to mandible-base 1.15 - 1.50, width 1.0 - 1.20 mm); sides convex, converging anteriorly; posterior margin rounded. Fontanelle gland tubular, visible from head-surface; opening at posterior margin of clypeus and with a brown chitinous rim. Eyes and ocelli absent. Antennae with 13-15 segments, segment 3 usually shortest, but variable, either equal to or slightly longer than 2 or 4; 5 onwards gradually increasing in length. Postclypeus narrow, trapezoid; anteclypeus also narrow, trapezoidal and apilose. Labrum subtriangular; with a pointed, hyaline apex; a little longer than broad (length 0.30 - 0.35, width 0.25 - 0.28 mm); broadest near base; with a pair of long bristles just below hyaline tip. Mandibles thin, sabre-shaped, with inwardly pointed apices. Left mandible with fairly large basal projection and 4 small well marked crenulations. Right mandible also with 4 but small to minute crenulations basally. Postmentum long, club-shaped; broadest at anterior one-third and from thence narrowing down to a thick waist at middle and again widening out at base (length 0.85 - 1.00, maximum width 0.35 - 0.40, minimum width 0.20 - 0.25 mm); anterior margin weakly convex, with a pair of hairs on either side; posterior margin concave. Pronotum flat, subreniform; a little broader than long (width 0.68 - 0.91, length 0.38 - 0.45 mm) and narrower than head; anterior margin convex with a well marked, obtuse, median notch; antero-lateral corners broadly rounded; posterior margin substraight with a faint median depression. Legs with femora long; tibiae long and slender; apical tibial spurs 3:2:2; tarsi 4-jointed. Abdomen elongate; styli one-jointed; cerci 2-jointed.

**WORKER** : Head-capsule pale yellowish, body paler. Head and abdomen densely pilose, hairs on abdomen not in rows. Total length 3.10 - 5.30 mm. Head-capsule subcircular, broader than long (width 0.88 - 1.25, length to base of mandibles 0.75 - 1.10 mm). Fontanelle, eyes and ocelli absent. Antennae with 12-15 segments. Clypeus, labrum and mandibles as in imago. Pronotum flat, much broader than long (width 0.48 - 0.75, length 0.20 - 0.40 mm); anterior margin weakly convex, with deep, median notch; posterior margin substraight, with faint median depression. Legs and abdomen as in soldier.

**Distribution** : SRI LANKA : Widely distributed throughout the country. INDIA : Southern India: Tamil Nadu (Coimbatore, Madras, Mandapam Camp, Krusadai Island), Andhra Pradesh (Eluru), Kerala (Trivandrum and environs, Peechi, Kallar). For details vide Roonwal and Chhotani 1962b, Bose 1984).

**Biology** : It is a very common wood-destroying termite in Sri Lanka and is reported to attack a large number of trees and plants including tea bushes, rubber and coconut trees and woodwork in buildings and wood in timber depots.

It is a subterranean species and attacks dead and diseased portions of trees, extending the damage to live tissue also. The nest in the tree trunks is in the form of spongy mass of wood carton. Nothing is known about its swarming behaviour; imagoes, however, have been collected from nest during the months of February, March and July in southern India and during December in Sri Lanka (Roonwal and Chhotani 1962b, Chhotani 1980).

### 63. *Coptotermes emersoni* Ahmad (Figs. 227, 228)

*Coptotermes emersoni* Ahmad :

1953. Ahmad, *Spol. Zeyl.*, 27(1): 37-38. S. Holotype: S, in National Mus., Colombo. Type-locality: Colombo, Sri Lanka.

1958. Ahmad, *Biologia*, Lahore, 4(1&2): 65.

1962. Roonwal and Chhotani, *Indian Species Termite Genus Coptotermes* (ICAR Ent. Monogr. 2): 9, 17-20, 74, 84-87 (Pls. 3, 4). (Detailed descriptions, etc.).

1983. Chhotani, *Orient. Insects*, 17: 117.

IMAGO : Unknown.

**SOLDIER** (Fig. 227) Head-capsule pale brownish with smoky tinge; antennae, labrum, pronotum and abdomen paler; anteclypeus whitish; mandibles reddish brown. Head with only one hair on each side of fontanelle; pronotum with a few bristles; abdominal terga densely pilose. Total length c 5.1 mm. Head-capsule pyriform, longer than broad (length to mandible-base 1.05-1.18, width 0.88-0.96 mm); posterior margin rounded.

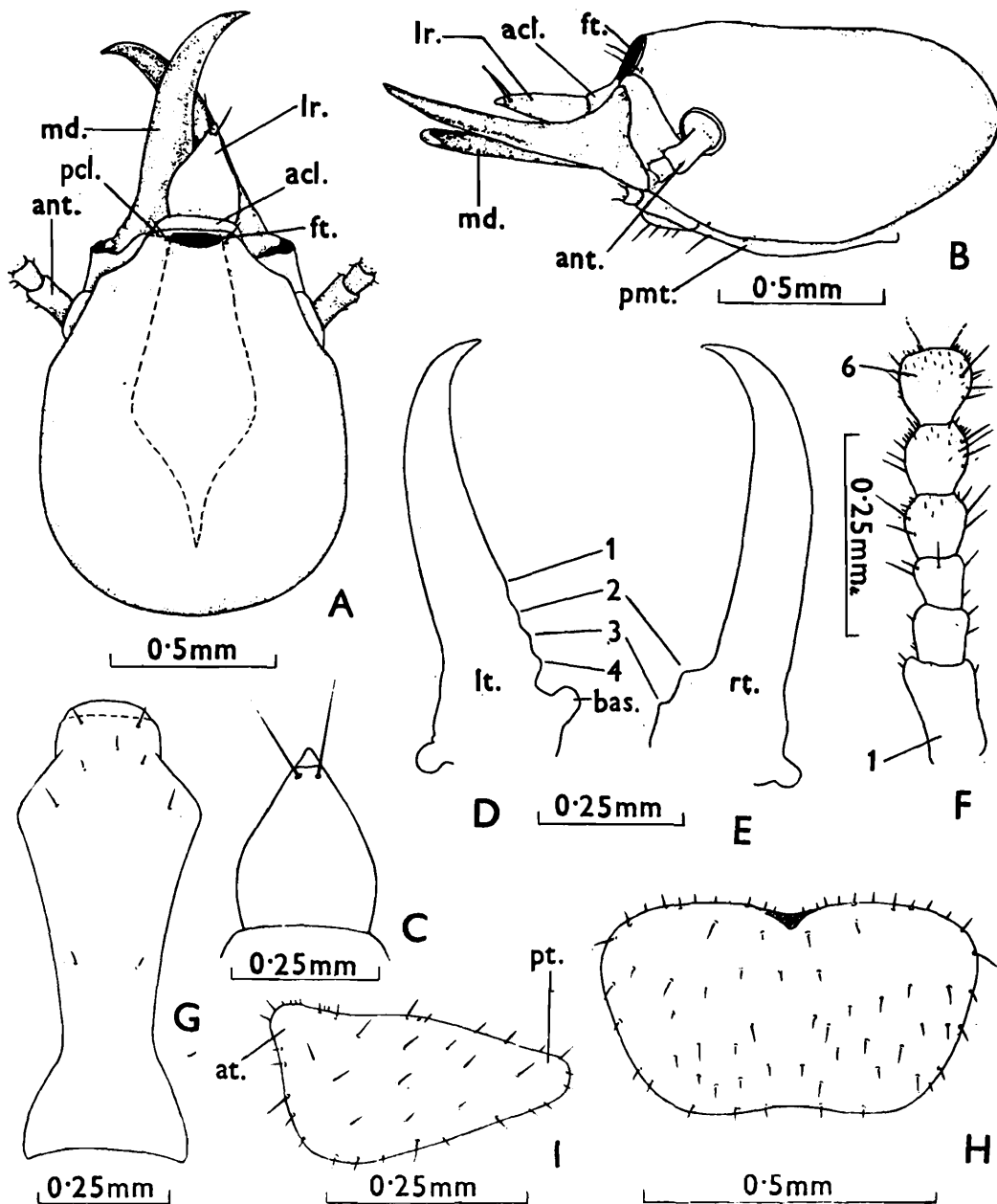

Fig. 227. *Coptotermes emersoni*. Soldier. (A) Head, in dorsal view. (B) Same, in side view. (C) Labrum. (D) Left mandible. (E) Right mandible. (F) Basal part of left antenna. (G) Postmentum. (H) Pronotum, in dorsal view. (I) Same, in side view. Lettering as in fig. 226. (After Roonwal and Chhotani, 1962b).

Fontanelle large, oval, opening with a chitinous, dark brown rim; lying just behind clypeus. Eyes and ocelli absent. Antennae with 13 segments; segment 3 smaller than 2 or 4. Postclypeus and anteclypeus narrow, trapezoidal, pale. Labrum subtriangular; apex pointed, with a pair of bristles; longer than broad (length 0.30, width 0.25 mm); widest a little above base. Mandibles sabre-shaped, incurved at apices. Left mandible

with 4 small crenulations and one large, knob-like projection and right with only 2 crenulations. Postmentum long, club-shaped; broadest at anterior one-third, narrowing behind to a waist at posterior one-third; anterior margin convex, posterior margin weakly concave; with a pair of hairs near anterior margin and a few on body (length 0.83, max. width 0.35, width at waist 0.18 mm). Pronotum much broader than long (width 0.57-0.66, length 0.28-0.35 mm); narrower than head; anterior margin slightly convex, with a weak, median notch; posterior margin also weakly convexical, with a broad and a weak median depression. Abdomen oblong; cerci 2-jointed; styli one-jointed, minute.

**WORKER** (Fig. 228) : Head-capsule anteriorly pale smoky brown, posteriorly dirty brown; antennae, labrum, legs and abdomen paler;

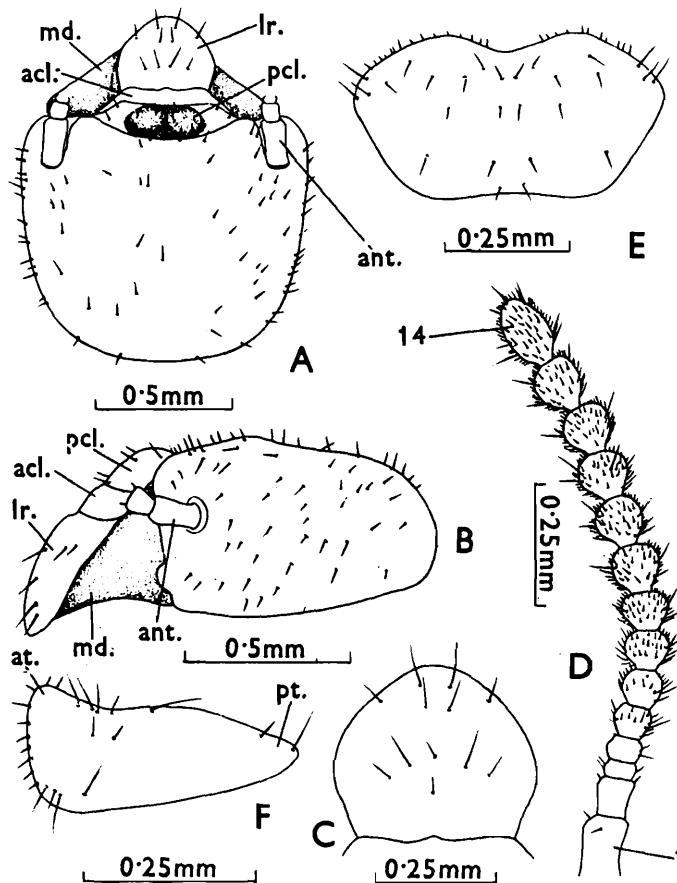

Fig. 228. *Coptotermes emersoni*. Worker. (A) Head, in dorsal view. (B) Same, in side view. (C) Labrum. (D) Left antenna. (E) Pronotum, in dorsal view. (F) Same, in side view. acl., anteclypeus; ant., antenna; at., anterior; lr., labrum; md., mandible; pcl., post-clypeus; pt., posterior (After Roonwal and Chhotani, 1962b).

mandibles pale brown with darker margins. Head-capsule fairly and abdominal terga densely hairy, abdominal hairs not in rows; pronotum with a few hairs on margins and body. Total length 4.60 mm. Head-capsule subcircular, width a little more than length (width 0.95, length to mandible-base 0.88 mm). Fontanelle, eyes and ocelli absent. Antennae with 14 segments; segment 3 shortest. Postclypeus weakly swollen and with a few hairs; anteclypeus narrow, trapezoidal, apilose. Labrum broader than long (width 0.35, length 0.33 mm); a few hairs present on anterior margin and on body. Mandibles of *Coptotermes*-type. Pronotum broader than long (width 0.60, length 0.30 mm); narrower than head; anterior margin convexical, with a deep, median notch; posterior margin weakly convex, with a slight median depression. Legs and abdomen as in soldier.

*Distribution* : SRI LANKA : Colombo, known only from type - locality.

#### 64. *Coptotermes formosanus* Shiraki

Synonyms : *Coptotermes formosanus* Holmgren, *Coptotermes formosae* Holmgren, *Coptotermes hongkonensis* Oshima, *Cryptotermes hongkongensis* Campbell, *Coptotermes intrudens* Oshima, *Termes raffrayi* Matsumura, *Coptotermes remotus* Silvestri, *Coptotermes* n. sp. Fuller.

(Figs. 229-231)

##### 1. *Coptotermes formosanus* Shiraki :

1909. *Coptotermes formosanus* Shiraki, *Trans. ent. Soc. Japan*, 2(10): 239-240.  
Holotype : Repository not known. Type-locality : Taihoku, Taiwan.
1915. Hozawa, *J. Coll. Sci. Tokyo Imp. Univ.*, 35(7): 92-105; Pl. 3, figs. 18-20. Im, Ny, S, W.
1919. Oshima, *Philipp. J. Sci.*, 19(4): 321-324; Pl. 1, figs. 1-3. Im, Q, K, S, W.
1929. Light, *Philipp. J. Sci.*, 40(4): 422, 432, 439.
1931. Light, *Lignan Sci., J.*, 7: 583, 584, 591-593.
1949. Snyder, *Smiths. misc. Colls.*, 112: 78.
1953. Ahmad, *Spol, Zeyl*, 27(1): 35-36.
1958. Ahmad, *Biologia*, Lahore, 4(1-2): 61, 64-65.
1961. Harris, *Termites : Recognition & Control* : 47, 54, 55, 57, 90, 93, 95, 96, 97, 101, 102, 103, 104, 109, 115, 167.

1962. Roonwal and Chhotani, *Indian Species Termite Genus Coptotermes* (ICAR Ent. Monogr. 2) : 8, 9, 20-30, 72, 73, 74, 88-91 (Pls. 5, 6). See for detailed synonymy, descriptions, etc.)
1964. Tsai and Chen, *Acta Entom. Sinica*, 13(1): 25-37.
1966. Ikehara, *Bull. Art. Sci. Div. Ryukyu Univ.*, No. 9: 49-176.
1967. Roonwal and Chhotani, *J. Bombay nat. Hist. Soc.*, 63(2) : 358.
1967. Gay, *Bull. Commonw. Sci. Industr. Res. Org.*, No. 286 : 13, 30-32, 73-75.
1969. Gay, In *Biology of Termites* (Eds. Krishna and Weesner) Vol. 1 : 468.
1970. Roonwal, In *Biology of Termites* (Eds. Krishna and Weesner) Vol. 2: 337-338.
1972. Chaudhry and Ahmad, *Termites of Pakistan* (Final Tech. Rept. PL-480 Proj.): 13.
1974. Akhtar, *Pakistan J. Zool.*, 6(1-2) : 90, 101.
1983. Chhotani, *Orient. Insects*, 17: 115, 117.
1984. Ping, *Trop. Subtrop. For. Ecosyst.*, 2: 184, 186, 189.
1987. Tamashiro and Su (Eds.). *Biology and Contr. of the Formosan Subterranean Termite. Res. Ext. Ser.*, 83: 1-61 (includes 10 contributions on the species *C. formosanus* by different authors).

2. *Coptotermes formosanus* Holmgren :

1913. Holmgren, *K. Sv. Vet. Akad. Handl.*, 50(2): 76-77; Pl. 2, Fig. 10(S).Im, S. W. (Conspecific with *C. formosanus* Shiraki vide Snyder 1949, p. 78). Syntypes probably in Holmgren Coll., National mus., Stockholm. Type-locality : Formosa.

3. *Coptotermes formosae* Holmgren :

1911. Holmgren In Escherich's *Termitenleben auf Ceylon*, : 192. Im. Syntypes probably in Holmgren Coll., National Mus., Stockholm. Type locality : Formosa.
1912. Holmgren, *Annot. Zool. Japan*, 8: 121-122. Im, S.,W.

4. *Coptotermes hongkonensis* Oshima :

1914. Oshima, *Annot. Zool. Japan*, 8: 559-560; Pl. 9, fig. 5. S.W. Holotype repository not known. Paratype W in AMNH, New York. Type-locality: Hongkong.

5. *Cryptotermes hongkongensis* Campbell :

1922. Campbell, cf. Snyder, 1949, p. 78.

6. *Coptotermes intrudens* Oshima :

1920. Oshima, *Proc. Hawaiian ent. Soc.*, 4(2): 262. Holotype : Repository not known. Type-locality : Honolulu (Hawaii Isl.)

7. *Termes raffrayi* Matsumura :

1910. Matsumura, *Die schadlichen und nutzlichen Insecten von Zuckerrohr Formosas*, Tokyo : 1. Holotype : Repository not known. Type-locality : Taiwan.

8: *Coptotermes remotus* Silvestri :

1928. Silvestri, *Boll. Lab. Zool. Gen. Agric. Portici*, 21: 93. Im, S. Types : Probably in Silvestri Coll., Naples (Italy). Type-locality : Simonstown (Cape Prov., S. Africa).

9. *Coptotermes* n. sp. Fuller. :

1925. Fuller, *J. Un. S. Africa Dept. Agric. Ser.*, 18: 1.

10. *Coptotermes formosanus* Shiraki (Wrong determination):

1920. Oshima, *Philipp. J. Sci.*, 17(5): 491-492. (Is *C. vastator* Light).

11. *Coptotermes formosanus* Shiraki (Part) :

1921. Light, *Philipp. J. Sci.*, 18(3): 250. (Specimens other than those from Philippines are *formosanus*).

12. *Coptotermes/Termes gestroi* Wasmann (Wrong determination) :

1910. Oshima, *Dobutsugaku Zasshi*, 22: 376.

1910. Nawa, *Konchu Sekai, (Insect World)*, 14: 597.

1911. Oshima, *Konchu Sekai*, 15: 359.

**IMAGO (Figs. 229, 230):** Head-capsule yellowish brown to dark brown; antennae, labrum, pronotum and body paler; wings slightly yellowish. Head fairly and pronotum and body densely pilose; wings densely pilose with small setae, wing scales with longer hairs. Total length with wings 14.00-16.00 mm, without wings 6.50-9.60 mm. Head-capsule subcircular, wider than long (width with eyes 1.50-1.71, length to mandible-base 1.20-1.30 mm); slightly swollen in between ocelli; frons very weakly sloping anteriorly. Fontanelle minute, circular; at the middle of head and slightly raised. Eyes fairly large, subcircular (maximum diameter 0.43-0.45 mm); situated at a distance of 0.05 mm from antennae. Ocelli oval, translucent, maximum diameter 0.16-0.20 mm; situated at a distance of 0.03-0.05 mm from eyes. Antennae with 20-21 segments; segment 3 short, shorter than 2 and subequal to 4. Postclypeus yellowish, weakly swollen; anteclypeus apilose, trapezoidal. Labrum broader than long (width 0.50-0.53, length 0.38-0.45 mm); with a few hairs near anterior margin and on body. Mandibles as in genus. Pronotum subreniform, much wider than long (width 1.30-1.52, length 0.80-0.93 mm); narrower than head-width with

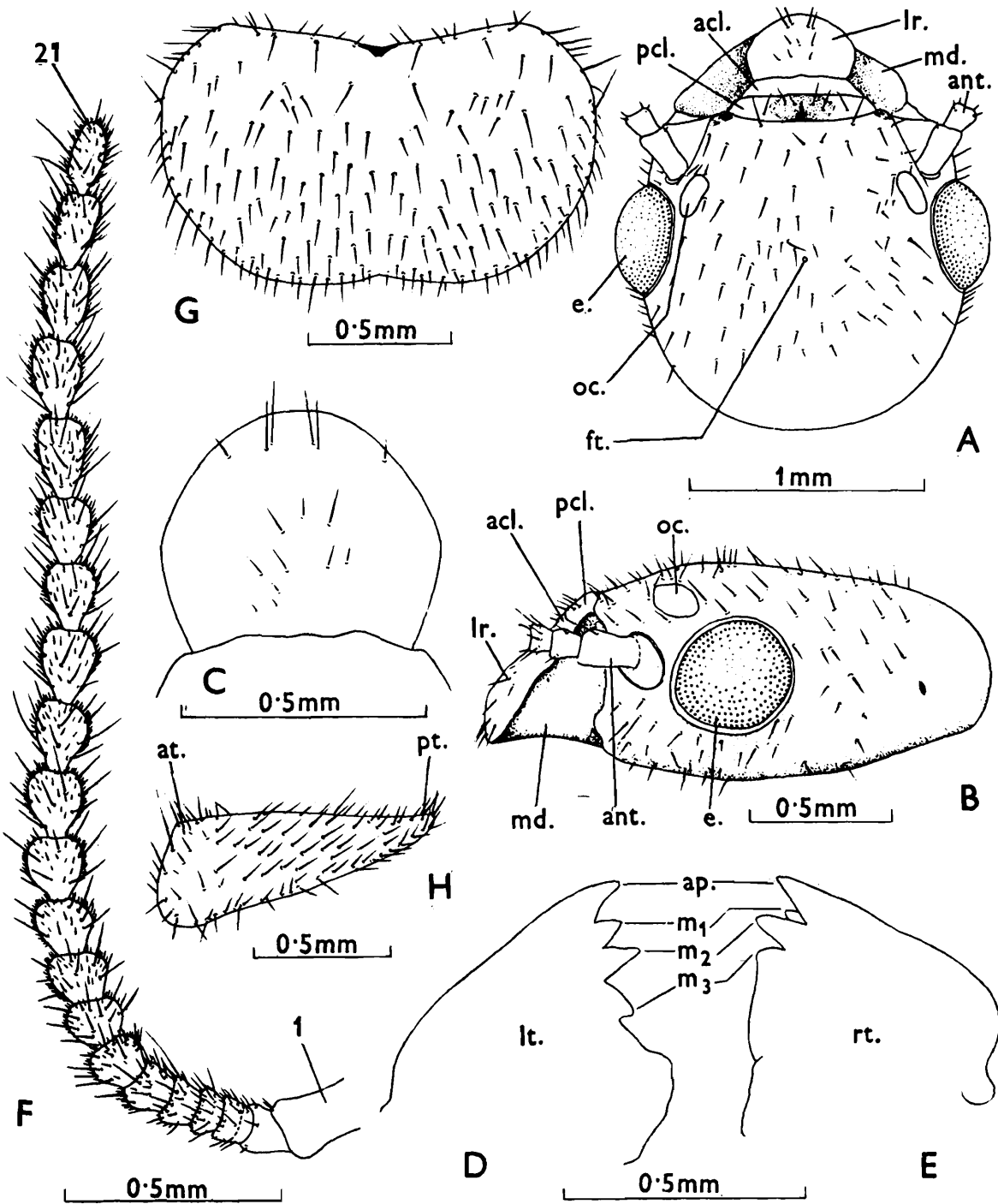

Fig. 229. *Coptotermes formosanus*. Imago. (A) Head, in dorsal view. (B) Same, in side view. (C) Labrum. (D) Left mandible. (E) Right mandible. (F) Antenna. (G) Pronotum, in dorsal view. (H) Same, in side view. Lettering same as fig. 224. (After Roonwal and Chhotani, 1962b).

eyes; anterior margin weakly concave; posterior margin convex with a median notch. Legs thin, femora and tibiae long; apical tibial spurs 3:2:2; tarsi 4-jointed. Wings densely covered with hairs; papillae along anterior margin and pimpules in proximal one-third, present. Venation as in genus. Abdomen elongate; cerci 2-jointed; styli single-jointed.

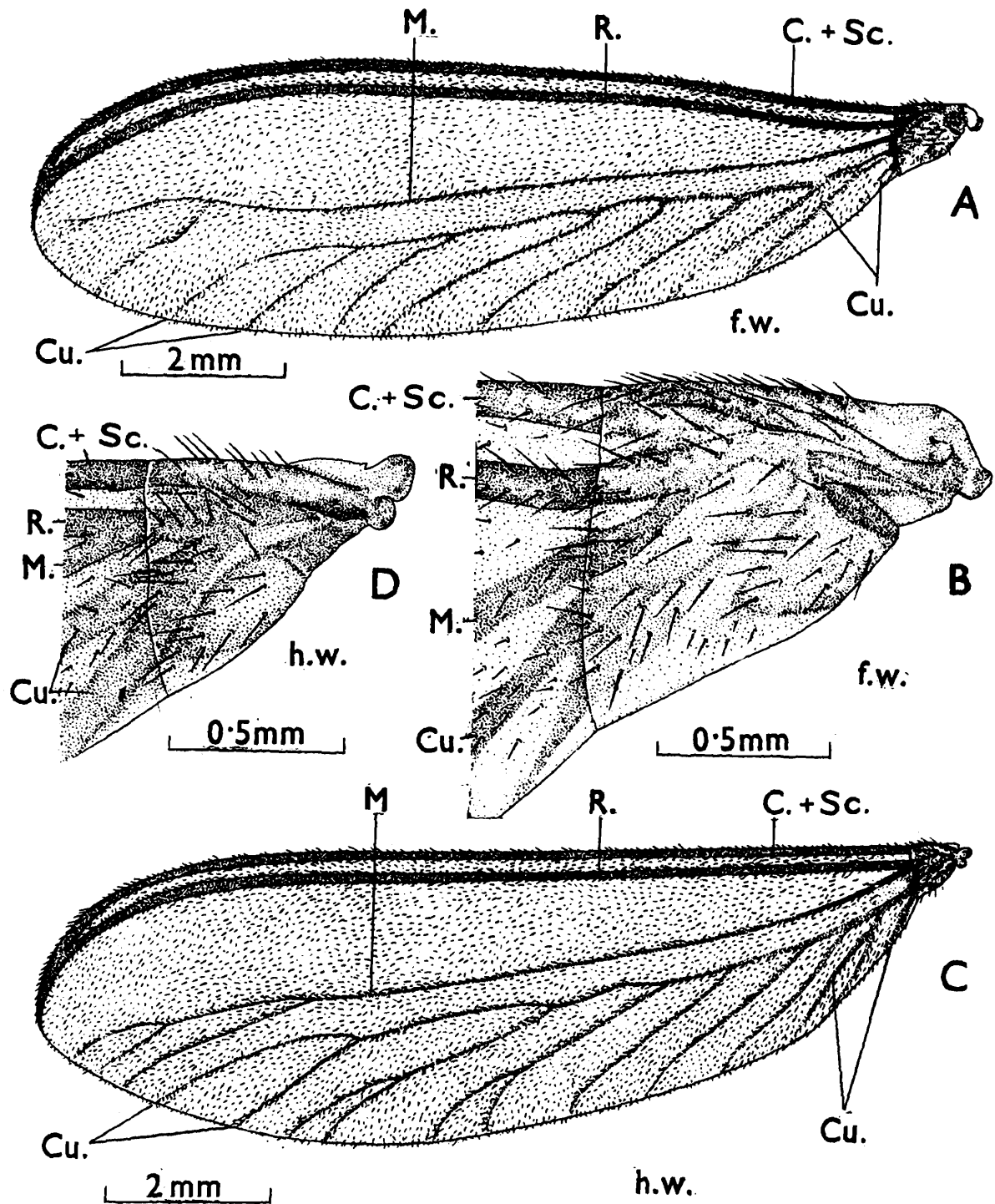

Fig. 230. *Coptotermes formosanus*. Wings. (A) Left forewing. (B) Same, scale and basal portion, enlarged, to show origin of veins. (C) Left hindwing. (D) Same, basal portion enlarged. Lettering same as in fig. 225. (After Roonwal and Chhotani, 1962b).

**SOLDIER** (Fig. 231) : Head-capsule and postclypeus dirty yellowish, fontanelle area on head translucent, paler; antennae, labrum, pronotum and body pale yellow; mandibles reddish brown to dark brown. Head sparsely pilose, with 2 setae on either side of fontanelle; pronotum fairly pilose and

abdominal terga with a posterior marginal row and a few, irregularly placed hairs on body. Total length 5.00-6.90 mm. Head-capsule subrectangularly oval, longer than broad (length to mandible-base 1.43-1.65, width 1.05-

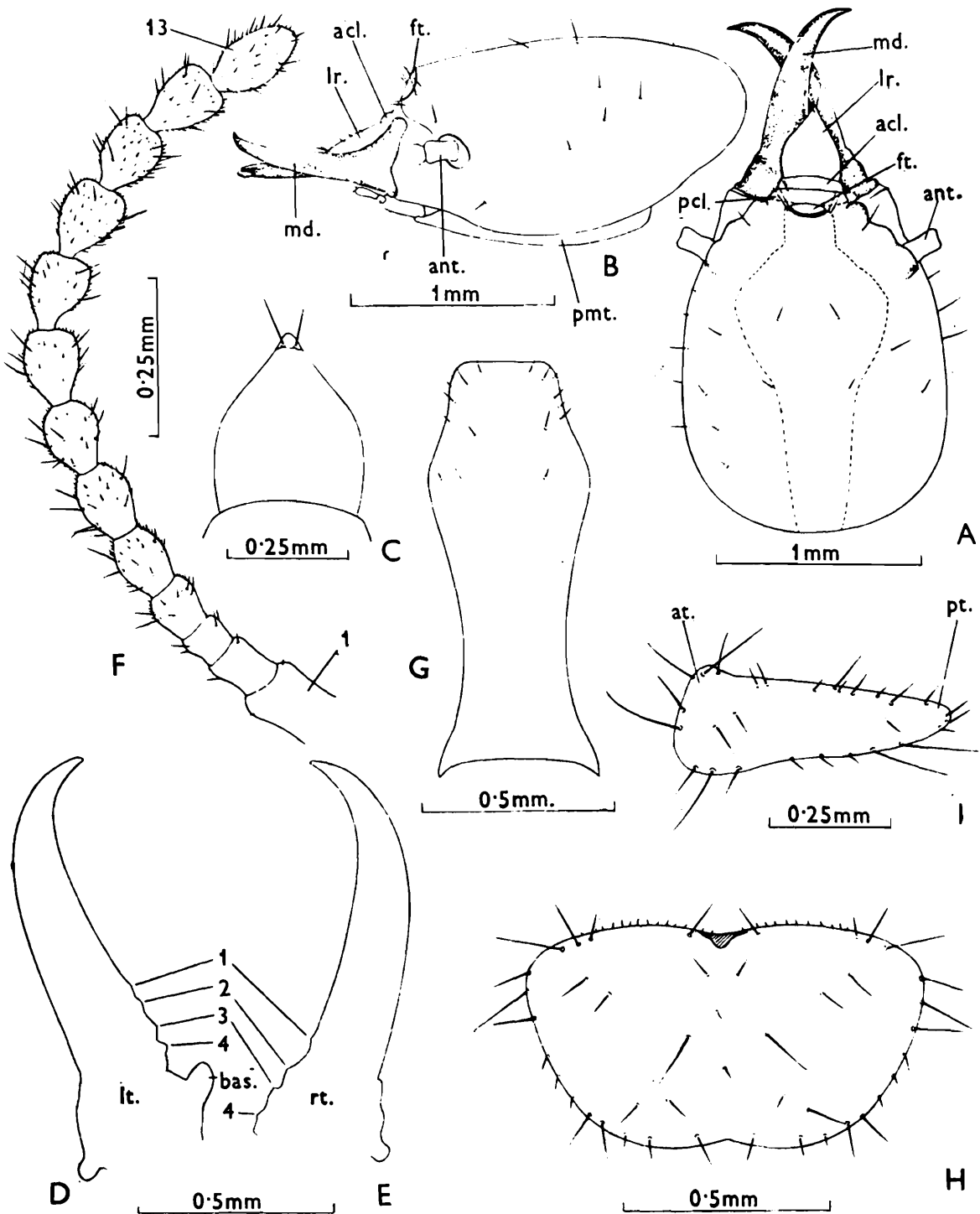

Fig. 231. *Coptotermes formosanus*. Soldier. (A) Head, in dorsal view. (B) Same, in side view. (C) Labrum. (D) Left mandible. (E) Right mandible. (F) Left antenna. (G) Postmentum. (H) Pronotum, in dorsal view. (I) Same, in side view. Lettering same as in fig. 226. (After Roonwal and Chhotani, 1962b).

1.30 mm); sides substraight, converging anteriorly; head dorsum behind fontanelle not swollen. Fontanelle large, subcircular; opening with a chitinoid border; situated just below clypeus. Eyes and ocelli absent. Antennae with 13-15 segments; segment 3 either shorter than or subequal to 2 or 4; from 5 onwards increasing in size, pear-shaped. Postclypeus subrectangular with a few hairs and separated from frons by a weak ridge along anterior border of fontanelle. Anteclypeus apilose, narrow, trapezoid and translucent. Labrum subtriangular, longer than broad (length 0.30-0.38, width 0.25-0.33 mm); broadest a little below middle; sides converging to a pointed, hyaline tip; with 2 or 3 long hairs at apex and few short ones on body. Mandibles long (length 0.95-1.03 mm), sabre-shaped; basally broad, narrowing to sharply incurved apex. Left mandible with four crenulations and a basal projection on inner margin in basal half and right with four crenulations on inner margin in basal one-third. Postmentum shorter than head (length 0.88-1.08 mm); broadly club-shaped; broadest at anterior one-third (max. width 0.40-0.43 mm), from whence converging to a substraight anterior margin and posteriorly narrowing to a broad waist at about basal one-fourth and again widening out at base; with a few bristles in anterior one-third. Pronotum flat, subreniform; much broader than long (width 0.75-0.93, length 0.40-0.53 mm); narrower than head; anterior and posterior margins convex and medially notched. Legs long, thin; tibial spurs 3:2:2; tarsi 4-jointed. Abdomen oblong; cerci 2-segmented; styli single-jointed.

**WORKER :** Head-capsule dirty yellow to pale yellow; antennae, labrum, pronotum, legs and body paler; mandibles yellow with brown margins. Head fairly and pronotum and body densely hairy. Total length 4.00-5.65 mm. Head subcircular, broader than long (width 1.05-1.37, length to mandible-base 0.93-1.25 mm). Antennae with 13-14 segments; segment 3 shorter or subequal to 2 or 4. Fontanelle, eyes and ocelli absent. Clypeus, labrum and mandibles as in imago. Pronotum subreniform, much broader than long (width 0.60-0.80, length 0.28-0.45 mm); anterior margin convex, deeply notched; posterior margin weakly convex with a slight median depression. Legs and abdomen as in soldier.

**Distribution :** From the Indian Region, this species is recorded only from Colombo (Sri Lanka) and Karachi (Pakistan); at both these places it is

reported to be introduced. At the latter locality (i.e., Karachi) it is, however, collected from a nest in the inner portion of *Acacia modesta* (Chaudhry and Ahmad 1972), showing thereby that it is taking a foot-hold in the Indian subcontinent and since it is a very destructive species, it is quite alarming.

This species is very widely distributed in Taiwan, southern China and Japan and reported to be introduced to Hawaii Isl. and southern U.S.A., Brazil and South Africa. For detailed distribution vide Roonwal and Chhotani 1962b, Chhotani 1985, Abe 1937a & b, Ikehara 1966 and Su and Tamashiro, 1987.

**Biology :** It is a very widely distributed species in the world, having been introduced to far away places from its original home in China through trade and driftwood. It is very injurious to woodwork, structural timber and other cellulosic stored materials and has also been reported from many live trees. It is a serious pest of sugarcane and fruit trees in Hawaii. Swarming occurs in the evenings from April to July at the beginning of rainy season or even earlier in spring. Smaller swarms, however, have been observed almost every month under suitable environmental conditions.

### 65. *Coptotermes gaurii* Roonwal and Krishna (Figs. 232, 233)

#### 1. *Coptotermes gaurii* Roonwal and Krishna :

1955. Roonwal and Krishna, *Indian J. agric. Sci.*, 25(2): 143-152. S, W. Holotype : S, in FRI, Dehra Dun. Type-locality : Sri Lanka: Merambekenda.

1962. Roonwal and Chhotani, *Indian Species Termite Genus Coptotermes* (ICAR Ent. Monogr. 1) : 9, 30-34, 75, 92-95 (Pls. 7, 8). S, W. (Synonymy, descriptions, etc.)

1967. Roonwal and Chhotani, *J. Bombay nat. Hist. Soc.*, 63(2): 358.

1977. Maiti. *Proc. zool. Soc. Calcutta*, 30: 133, 134.

1983. Chhotani, *Orient. Insects*, 17: 117.

#### 2. *Coptotermes exiguus* Kemner (Nom. nud.):

1930. Jepson, *Trop. Agric.*, 75(3): 155.

1931. Jepson, *Tech. Rep. Dep. Agric. Ceylon*, 1929:6.

1949. Snyder, *Smiths. misc. Colls.*, 112: 346.

1953. Roonwal and Pant, *Indian For, Leaflet. (Ent.)*, No. 121(3): 47.

3. *Coptotermes exiguus* Hagen/*Eutermes exiguus* Desneux (Wrong determination) :

1953. Rattan Lal and Menon, *Cat. Indian Insects, Part 27, Isoptera* : 25.

4. *Coptotermes ceylonicus* Holmgren (Part) :

1953. Roonwal and Pant, *Indian For. Leaflet (Ent.)*, No. 121 (3): 47 (Specimens from Merembekenda only).

IMAGO : Unknown.

**SOLDIER (Fig. 232) :** Head-capsule pale yellow; antennae, pronotum, legs and abdomen paler; mandibles brownish, yellow basally. Head with a few erect hairs and two small bristles on either side of fontanelle; pronotum with short hairs on anterior margin and larger ones on posterior margin and on sides and body; abdominal terga densely and irregularly pilose. Total length 3.08-3.65 mm. Head-capsule pear-shaped, slightly longer than broad, head-length to mandibles-base 1.03-1.08, width 0.91-1.03 mm; rounded upto base of antennae and then sharply converging in front; posteriorly rounded. Fontanelle prominent, tubular with suboval opening at base of clypeus; surrounded by chitinoid border. Eyes and ocelli absent. Antennae with 14 segments; segment 3 smaller and narrower than 2 and shorter or subequal to 4; from 5 pear-shaped and increasing in size. Postclypeus and anteclypeus short narrow, trapezoidal. Labrum subtriangular, longer than broad, length 0.23, width 0.17 mm; sides basally subparallel then converging to a short, hyaline apex with 2 long bristles near tip. Mandibles not very long, length 0.57-0.63, sabre-shaped, basally broad then tapering to a slightly incurved apex. Left mandible with inner margin smooth in distal half and with 4 (sometime 5) crenulations and a basal projection in proximal half. Right mandible with inner margin smooth and 3 crenulations near base. Postmentum short (median length 0.57-0.63 mm); widest at anterior one-third (0.29-0.34 mm), from whence sides converging anteriorly to a substraight anterior margin and posteriorly to form a broad waist at about basal one-third (minimum or waist width 0.23-0.29 mm) and then widening out to a weakly concave posterior margin. Pronotum flat, much broader than long (width 0.57-0.68, length 0.37-0.40 mm); much narrower than head; anterior margin convex with deep, median notch; posterior margin convex with shallow, median notch. Legs with femora long; tibiae slender and with 3:2:2 apical tibial spurs. Abdomen densely pilose; styli one-segmented, cerci 2-segmented.

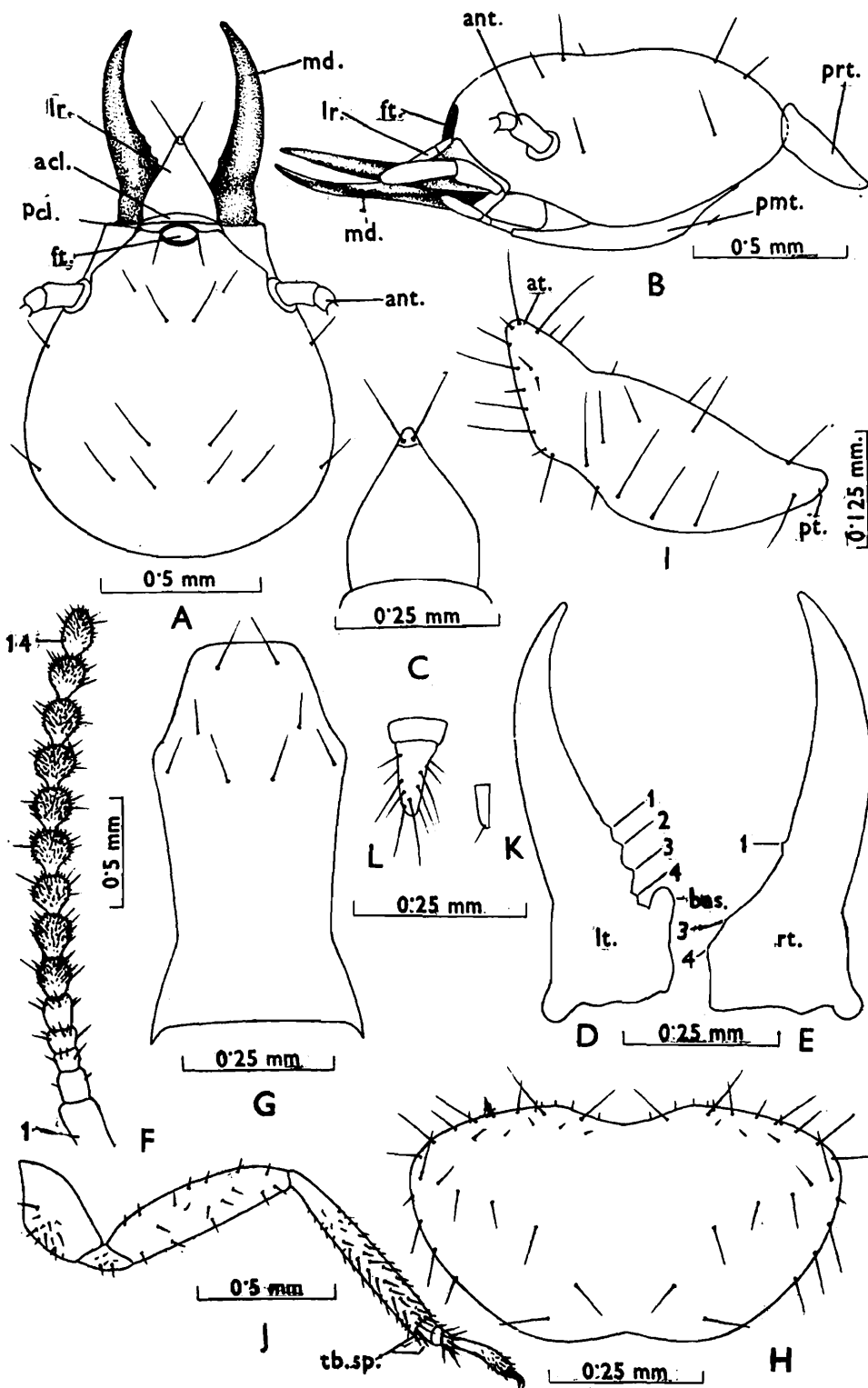

Fig. 232. *Coptotermes gaurii*. Soldier. (A) Head, in dorsal view. (B) Head and pronotum, in side view. (C) Labrum. (D) Left mandible. (E) Right mandible. (F) Left antenna. (G) Postmentum. (H) Pronotum, in dorsal view. (I) Same, in side view. (J) Hindleg. (K) Stylus. (L) Cercus. Lettering same as in fig. 226 (After Roonwal and Chhotani, 1962b).

**WORKER (Fig. 233) :** Head-capsule yellow; antennae, legs and pronotum paler; abdomen dirty white. Head thickly pilose, abdominal terga with dense irregular hairs. Total length 2.74-2.91 mm. Head-capsule

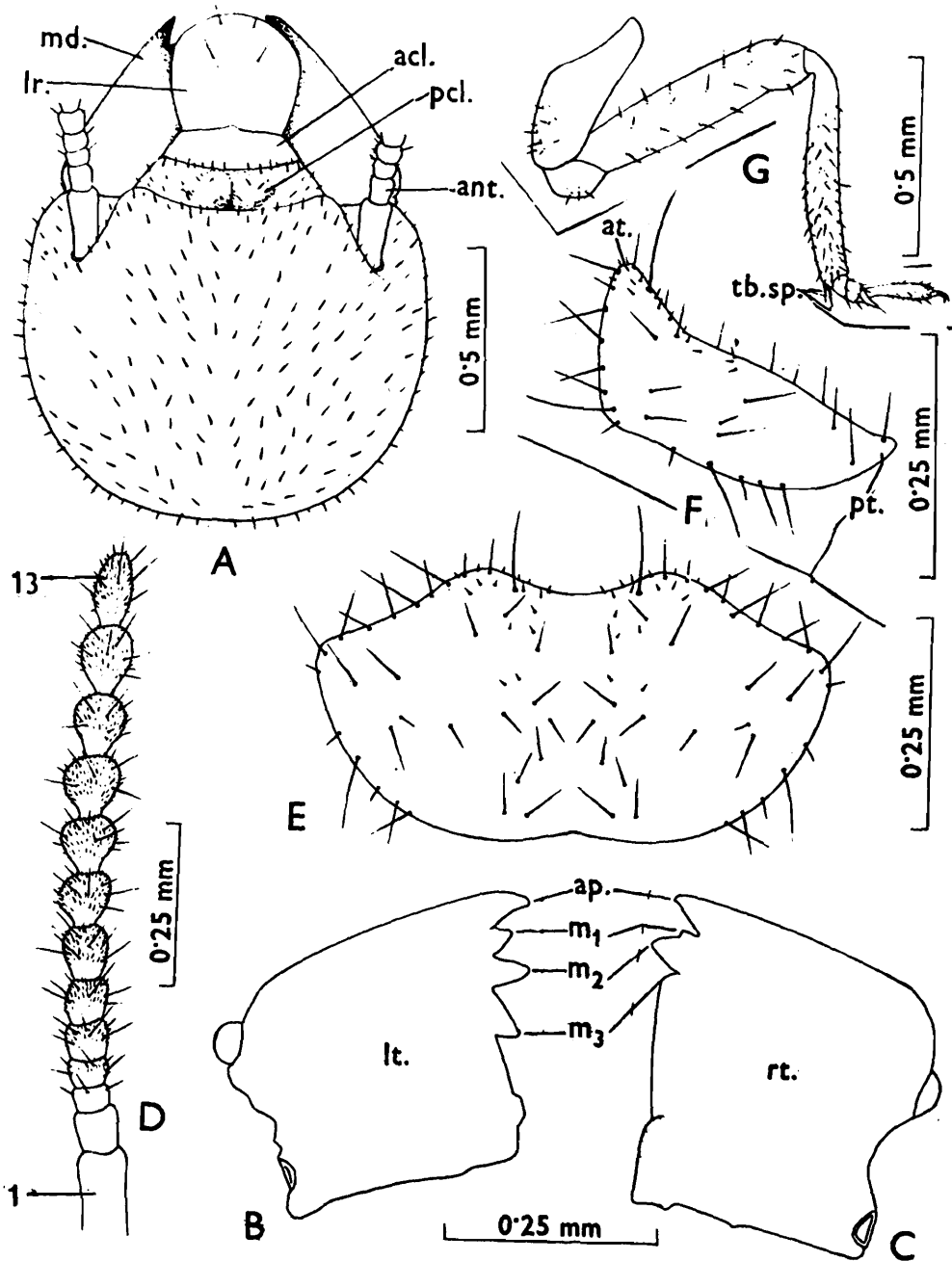

Fig. 233. *Coptotermes gaurii*. Worker. (A) Head, in dorsal view. (B) Left mandible. (C) Right mandible. (D) Antenna. (E) Pronotum, in dorsal view. (F) Same, in side view (G) Hindleg. Lettering same as figures 224 and 228 (After Roonwal and Chhotani, 1962b).

subrounded, broader than long (width 1.03, length to mandible-base 0.91 mm). Fontanelle, eyes and ocelli absent. Antennae with 12-15 segments; segments 3 and 4 subequal, shortest. Labrum broader than long (width 0.34, length 0.29-0.34 mm); with a few hairs on anterior part of body. Mandibles of *Coptotermes*-type. Pronotum much broader than long, (width 0.51-0.57, length 0.29 mm); anterior margin much projected in front and with a deep, obtuse, median incurving; posterior margin convexical with a shallow, medial depression. Legs and abdomen as in soldier.

*Distribution* : SRI LANKA : Merembekenda, known only from type-locality. INDIA : Great Nicobar Is..

### 66. *Coptotermes gestroi* Wasmann (Figs. 234, 235)

#### 1. *Termes (Coptotermes) gestroi* Wasmann :

1896. Wasmann, *Ann. Mus. Civ. Stor. Nat. Genova.*, (2) 16: 628-629. S. Holotype : Not designated by Wasmann. Syntypes not traceable in Wasmann Coll. in Nat. Hist. Mus., Maastricht. Type-locality : Bhamo, Burma.

1904. Desneux, *Genera Insect.*, Fasc. 25: 34. (Part, specimens from Burma only are *gestroi*).

#### 2. *Coptotermes gestroi* Wasmann :

1913. Holmgren, *K. Sv. Vet. Akad. Handl.*, 50(2): 78, 266-267. Soldier.

1917. Holmgren and Holmgren, *Mem. Dept. Agric. India (Ent.)*, 5(3): 145.

1934. Margabandhu, *J. Bombay nat. Hist. Soc.*, 37(3): 704.

1949. Snyder, *Smiths. misc. Colls.*, 112: 78. (Records from Malaya are *curvignathus*).

1958. Ahmad, *Biologia*, Lahore, 4(1-2): 64.

1962. Roonwal and Chhotani, *Indian Species Genus Coptotermes* (ICAR Ent. Monogr. 2): 8, 9, 34-38, 72, 75, 96-99 (Pls. 9, 10). S, W. (See for detailed synonymy, descriptions, etc.)

1962. Roonwal and Chhotani, *Proc. natn. Inst. Sci. India*, (B) 28(4): 306, 307, 393.

1965. Ahmad, *Bull. Am. Mus. nat. Hist.*, 131(Art. 1): 17, 22-23.

1965. Mathur and Thapa, *Bull. Ent.*, No. 6: 2, 3.

1965. Roonwal and Chhotani, *J. Bombay nat. Hist. Soc.*, 62(1): 22, 23.

1973. Morimoto, *Bull. Govt. For. Exp. Sta.*, No. 257: 61.

1963. Chhotani, *Orient. Insects*, 17: 117.

1986. Grassé, *Termitologia* Vol. 3: 523.

**IMAGO : Unknown.**

**SOLDIER (Fig. 234) :** Head-capsule pale yellowish to yellow; fontanelle area translucent whitish; antennae, labrum, pronotum, legs and abdomen paler. Head with a few erect bristles including one on either side of fontanelle; pronotum with short setae on anterior margin and longer ones on all margins and body and abdominal tergites with a row of setae on posterior margin and a few on body. Total length 4.00-5.60 mm. Head-capsule oval, longer than broad (length to mandible-base 1.40-1.53, width 1.14-1.25 mm); dorsum of head behind fontanelle almost straight in profile, not swollen; sides weakly convex, converging anteriorly; posterior margin rounded. Fontanelle large, opening with a brown chitinoid border. Eyes and ocelli absent. Antennae with 14-15 segments; segment 3 shortest; from 4 gradually increasing in size. Postclypeus not well differentiated from frons. Anteclypeus apilose, hyaline, trapezoidal and narrow. Labrum subtriangular, longer than broad (length 0.33-0.35, width 0.30 mm); sides narrowing distally to a hyaline apex, distal tip with one long bristle on either side. Mandibles sabre-shaped, length 0.82-0.93; narrowing distally to a sharp, pointed, incurved apex. Left mandible with inner margin with 4 well marked crenulations in basal half and a basal projection and right with 4 weaker crenulations in basal broader portion but no projection. Postmentum club-shaped, long (length 0.93-1.08 mm); broadest at anterior one-third (maximum width 0.40-0.45 mm); sides converging anteriorly to a rounded anterior margin, narrowing posteriorly to a fairly broad waist (width at waist 0.23-0.28 mm) and then widening out to a semi-concave posterior margin; a few bristle like hairs present in anterior part. Pronotum flat, subreniform, much broader than long (length 0.38-0.50, width 0.65-0.95 mm); narrower than head; anterior margin broadly convexical, with a median notch; posterior margin substraight, with a weak median depression. Legs long, slender, tibial spurs 3:2:2; tarsi 4-jointed. Abdomen elongate; cerci 2-segmented; styli one-segmented.

**WORKER (Fig. 235) :** Head-capsule and mandibles pale yellow; antennae, labrum, pronotum and abdomen paler. Head and body densely pilose. Total length 4.00-4.40 mm. Head-capsule squarishly subcircular, a little broader than long (width 1.30-1.33, length to base of mandibles 1.20-

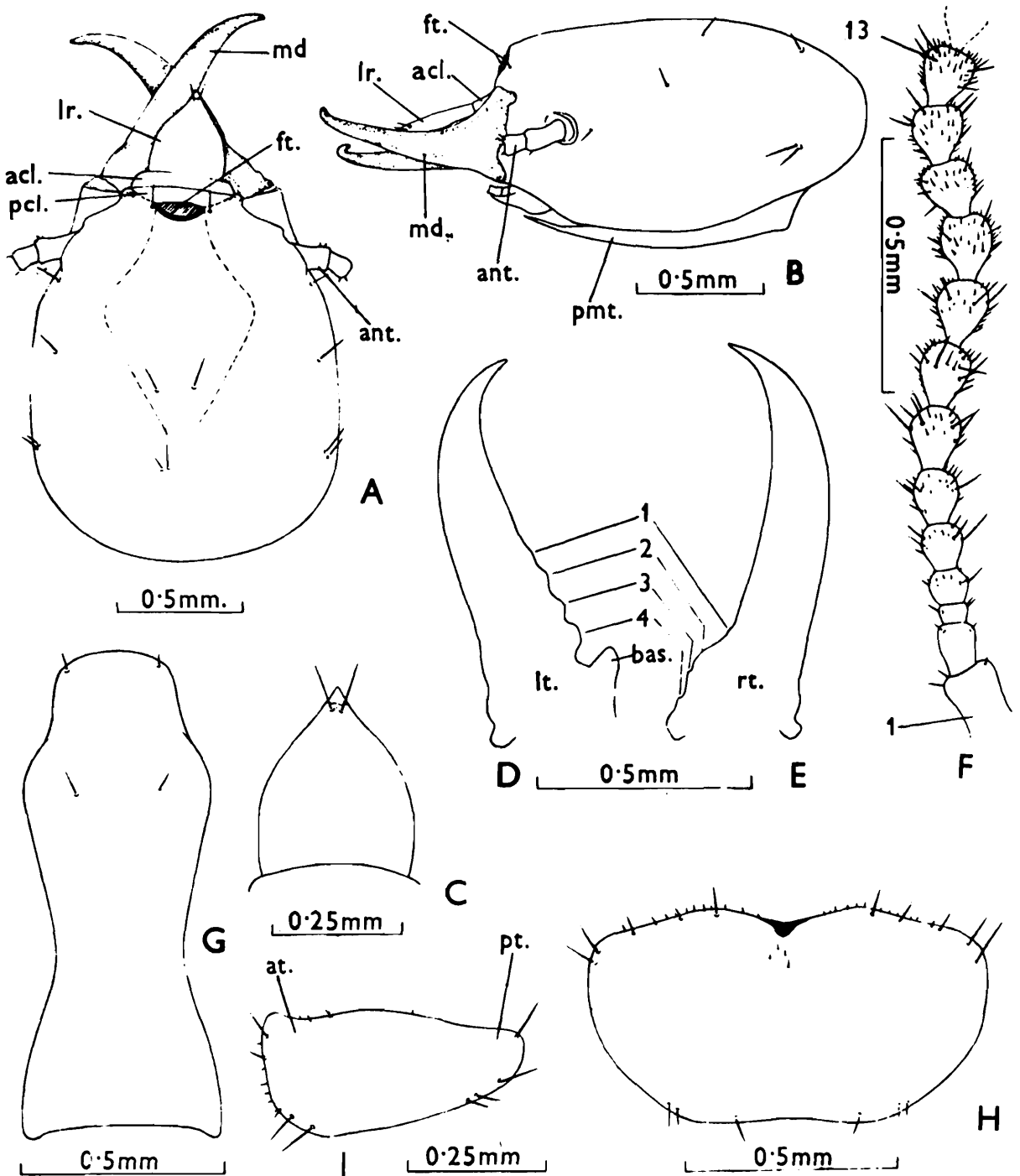

Fig. 234 *Coptotermes gestroi*. Soldier. (A) Head, in dorsal view. (B) Same, in side view. (C) Labrum. (D) Left mandible. (E) Right mandible. (F) Antenna. (G) Postmentum. (H) Pronotum, in dorsal view. (I) Same, in side view. Lettering same as fig. 226. (After Roonwal and Chhotani, 1962b).

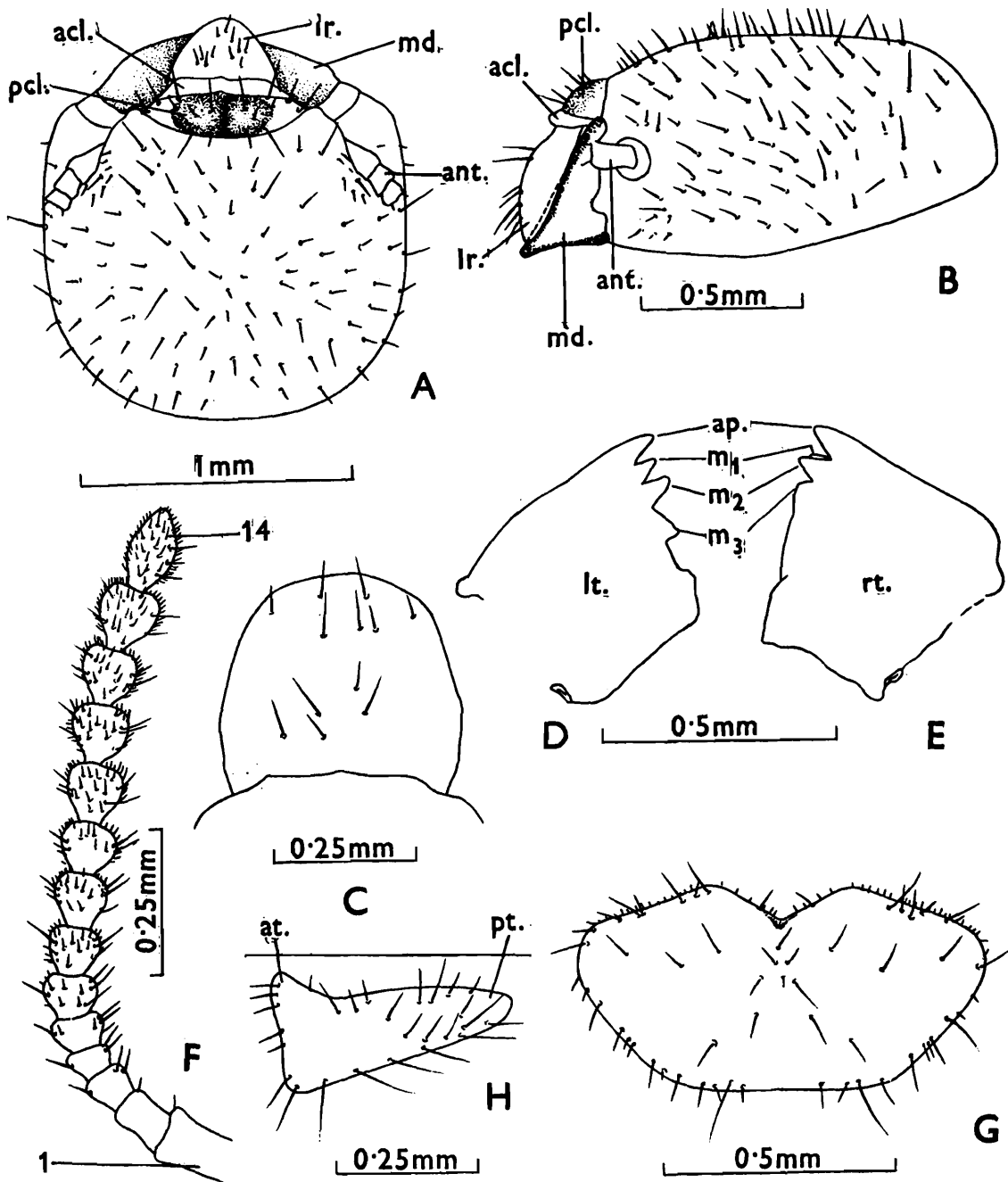

Fig. 235. *Coptotermes gestroi*. Worker. (A) Head, in dorsal view. (B) Same, in side view. (C) Labrum. (D) Left mandible. (E) Right mandible. (F) Left antenna. (G) Pronotum, in dorsal view. (H) Same, in side view. Lettering same as figs. 224 and 228. (After Roonwal and Chhotani, 1962b).

1.25 mm), broadest a little below antennae. Fontanelle, eyes and ocelli absent. Antennae with 14-15 segments, segment 3 shorter than or subequal to 2 or 4. Labrum subsquarish; broader than long (width 0.45, length 0.38 mm); anterior margin rounded; with a few bristles near anterior margin and on body. Mandibles of *Coptotermes*-type. Pronotum much broader than long (width 0.83-0.85, length 0.43-0.45 mm); anterior margin convex, with a deep median notch; posterior margin substraight. Legs and abdomen as in soldier.

*Distribution* : INDIA : Assam : Dibrugarh; Jeypore Forest Range, Lakhimpur. BURMA : Bhamo, type-locality. THAILAND : 20 km east of Mae Sod; Fang; Bangken, Bangkok and Khao Chong.

**67. *Coptotermes heimi* (Wasmann)**  
(Syn. *Coptotermes parvulus* Holmgren)  
(Figs. 236-241)

1. *Arrhinotermes heimi* Wasmann :

1902. Wasmann, *Zool. Jb. (Syst.)*, 17(1): 104; Pl. 4, figs. a-f. Im ; 160 (Syn.). Im. Type Im, in Wasmann. Coll., Natural History Museum, Maastricht (Holland), examined. Type-locality: India: Wallon (Ahmadnagar Dist., Maharashtra).

1904. Desneux, *Genera Insect., Isoptera*, Fasc. 25: 34.

1934. Margabandhu, *J. Bombay nat. Hist. Soc.*, 37(3): 703. (Wrongly states that it is described and recorded from Ceylon).

2. *Coptotermes heimi* (Wasmann):

1911. Holmgren, *K. Sv. Vet. Akad. Handl.*, 46(6): 73. India.

1912. Holmgren, *J. Bombay nat. Hist. Soc.*, 21(3): 777-778. Im, S, W.

1913. Holmgren, *K. Sv. Vet. Akad. Handl.*, 50(2): 74-75; Pl. 2, fig. 8, (S.). Im, S, W.

1917. Holmgren & Holmgren, *Mem. Dept. Agric. India (Ent.)*, 5(3): 144-145.

1949. Snyder, *Smiths. misc. Colls.*, 112: 79.

1953. Rattan Lal and Menon, *Catal. Indian Insects, Pt. 27, Isoptera*, (Erroneously mentioned as synonym of *C. travians* Havil.)

1954. Roonwal, *J. Bombay nat. Hist. Soc.*, 52(2): 465-466; Pl. 1, figs. 1-4.

1955. Ahmad, *Biologia*, Lahore, 1(2): 213-215.

1958. Ahmad, *Biologia*, Lahore, 4(1-2): 63, 64.

1961. Harris, *Termites : Recognition & Control* : 47, 92, 93, 101, 102, 107, 115.

1962. Roonwal and Chhotani, *Indian Species Termite Genus Coptotermes* (ICAR Ent. Monogr. 2): 8, 9, 38-57, 72-73, 76, 100-107 (Pls. 11-14). (See for detailed synonymy, descriptions, etc.)
1962. Roonwal and Chhotani, *Proc. natn. Inst. Sci. India*, (B) 28(3-4): 295, 308-309, 393.
1965. Roonwal and Chhotani, *J. Bombay nat. Hist. Soc.*, 62(1): 22, 23.
1967. Roonwal and Chhotani, *J. Bombay nat. Hist. Soc.*, 63(2): 355, 358; Pl. 2.
1967. Gay, *Bull. Commonw. Sci. Industr. Res. Org.*, No. 286: 13, 33-34.
1969. Gay, In *Biology of Termites* (Eds. Krishna and Weesner) Vol. 1 : 487.
1970. Roonwal, In *Biology of Termites* (Eds. Krishna and Weesner) Vol. 2: 338.
1970. Roonwal and Bose, *Rec. zool. Surv. India*, 62(3-4): 111, 116, 119, 122-123, 165, 166.
1972. Chaudhry and Ahmad, *Termites of Pakistan (Final Tech. Rept. PL-480 Proj.)* : 13-16.
1974. Akhtar, *Pakistan J. Zool.*, 6(1-2): 90, 101.
1975. Akhtar, *Bull. Dept. Zool. Panjab Univ., Lahore*, (N.S.), Art. 7: 36-42, 185, 191.
1975. Sen-Sarma et. al., *Wood Destroying Termites of India (Final Tech. Rept. PL-480 Proj.)*: 1, 2, 4, 12, 26, 27-29, 47, 64, 66, 71, 168, 169.
1976. Chhotani, *Newslet. zool. Surv. India*, 2(1): 12.
1977. Roonwal and Chhotani, *Ent. Basil*, 2: 48-50.
1979. Chhotani and Bose, *Zoologiana*, No. 2: 19, 20; pl 1, fig. 2.
1980. Chhotani, *Tech. Monogr. Zool. Surv. India*, No. 4: 30, 31-32.
1980. Bose, *Rec. zool. Surv. India*, 77: 99.
1981. Chhotani, In *Progress Soil Biology Ecology India* (Ed. G.K. Veeresh) : 230.
1982. Bose and Das, *Rec. zool. Surv. India*, 80: 199, 202.
1982. Grassé, *Termitologia* Vol. 1: 45.
1983. Maiti, *Occ. Pap. Rec. zool. Surv. India*, No. 42 : 17, 23, 48-51, 144, Map. 1.
1983. Chhotani, *Orient. Insects*, 17: 114, 117.
1984. Bose, *Occ. Pap. Rec. zool. Surv. India*, No. 49: 71, 81, 82, 85-88.
1985. Chhotani, *Z. ang Ent.*, 100: 91.
1985. Roonwal, *Proc. Indian natnl. Sci. Acad.*, (B) 51(2) : 150 (Pl. 12.)
1986. Grassé, *Termitologia* Vol. 3: 375, 522, 523, 651.
1986. Roonwal, Verma and Bisen, *Proc. Indian natn. Sci. Acad.*, (B) 52 (2): 241, 245-246.

1987, Bose and Das, *Fauna of Orissa: State Fauna Series*, No.1 : 103, 108.

In press. Chhotani, *J. Oman Studies, Spec. Rept.* 3: 365.

3. *Coptotermes parvulus* Holmgren:

1913. Holmgren, *J. Bombay nat. Hist. Soc.*, 22(1): 102, 104, S,W. Holotype: Not selected; syntypes S and W in AMNH, New York and Holmgren Coll., National Mus., Stockholm. Type-localities. Anand and Vadtal (Gujarat, India).

1913. Holmgren, *K. Sv. Vet. Akad. Handl.*, 50 (2), 73-74. S and W.

1949. Snyder, *Smiths. misc. Colls.*, 112: 82.

1953. Rattan Lal and Menon, *Catal. Indian Insects, Part 27, Isoptera* : 26.

4. *Coptotermes travians* (Haviland) (Wrong determination) :

1910. Bugnion, *Ann. Soc. Ent. Fr.*, 79: 137.

For detailed synonymy also vide Roonwal and Chhotani, 1962.

**IMAGO (Figs. 236 A, 237-239):** Head-capsule yellowish brown to dark brown, paler at sides, fontanelle area paler; mandibles yellowish brown with

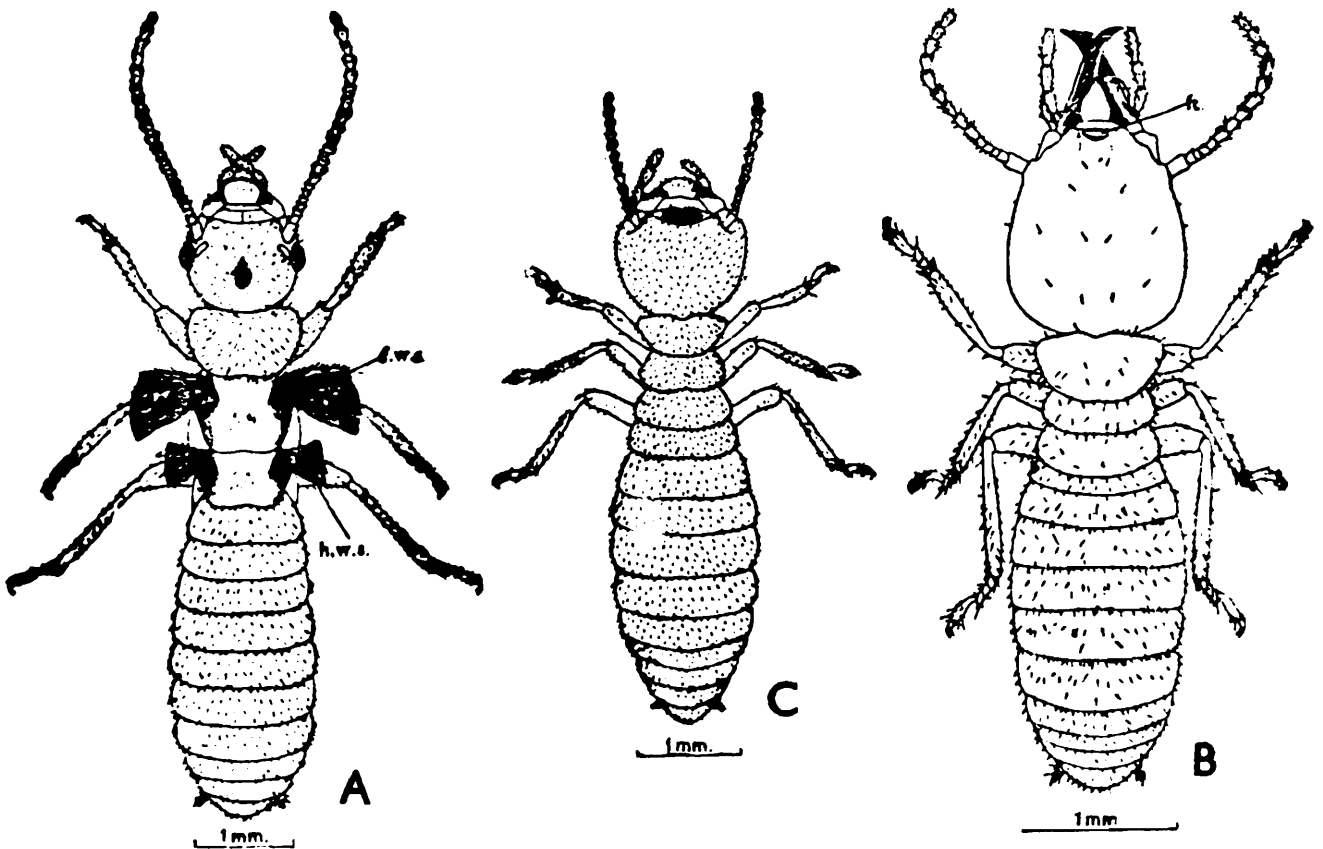

Fig. 236. *Coptotermes heimi*. Imago, soldier and worker. (A) Imago, whole body. (B) Soldier. (C) Worker.

ft., fontanelle; f.w.s., forewing scale; h.w.s., hindwing scale. (After Roonwal and Chhotani, 1962b).

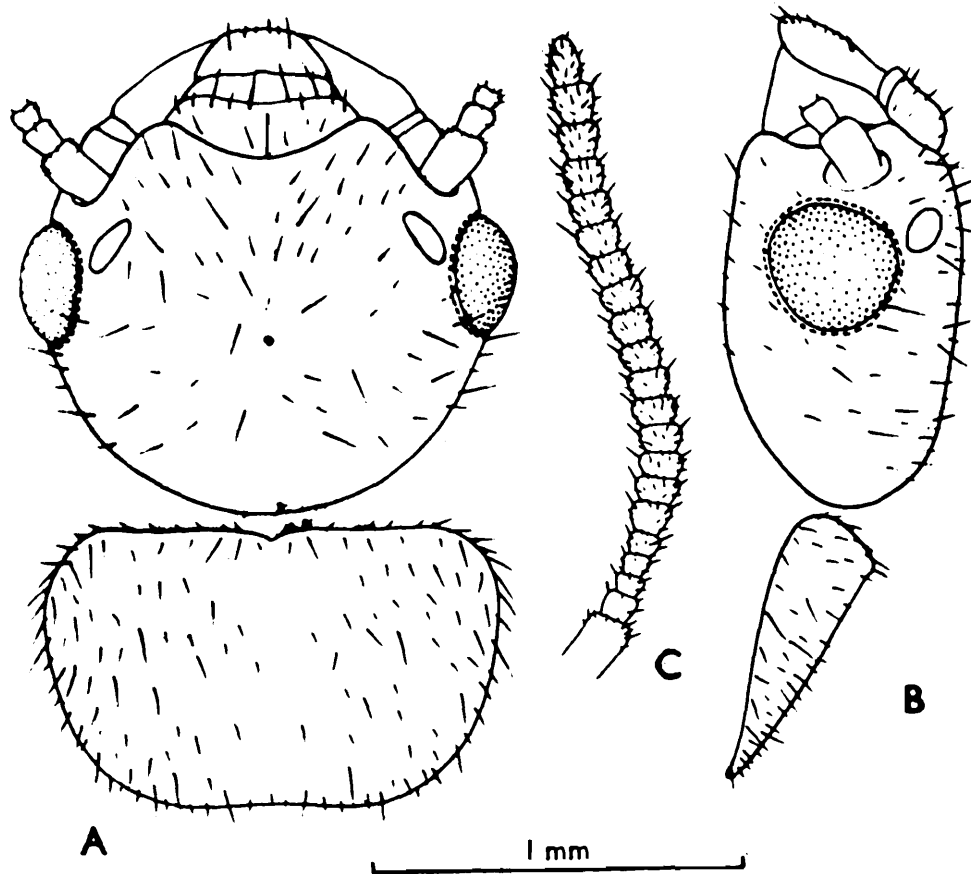

Fig. 237. *Coptotermes heimi*. Imago (Type). (A) Head and pronotum in dorsal view. (B) Same, in side view (C) Right antenna.

dark margins; labrum, antennae, postclypeus and legs yellowish; pronotum paler than head; wings transparent. Head fairly pilose; pronotum and abdomen densely pilose; wings with a dense covering of small hairs on membrane, wing scales with longer hairs. Total length with wings 10.6-12.3, without wings 5.6-7.0 mm. Head-capsule rounded (width with eyes 1.30-1.40, length to base of mandibles 1.04-1.16 mm); sides and posterior margin rounded; head-dorsum shallowly depressed in region of fontanelle. Fontanelle minute; indistinctly visible. Eyes subcircular, medium sized (maximum diameter 0.37-0.41 mm). Ocelli whitish, translucent, oval (maximum diameter 0.16-0.19 mm); either touching eyes or slightly separated (minimum eye-ocellus distance 0.012-0.037 mm, when separated). Antennae with 20-22 segments; segment 3 shortest; from 4

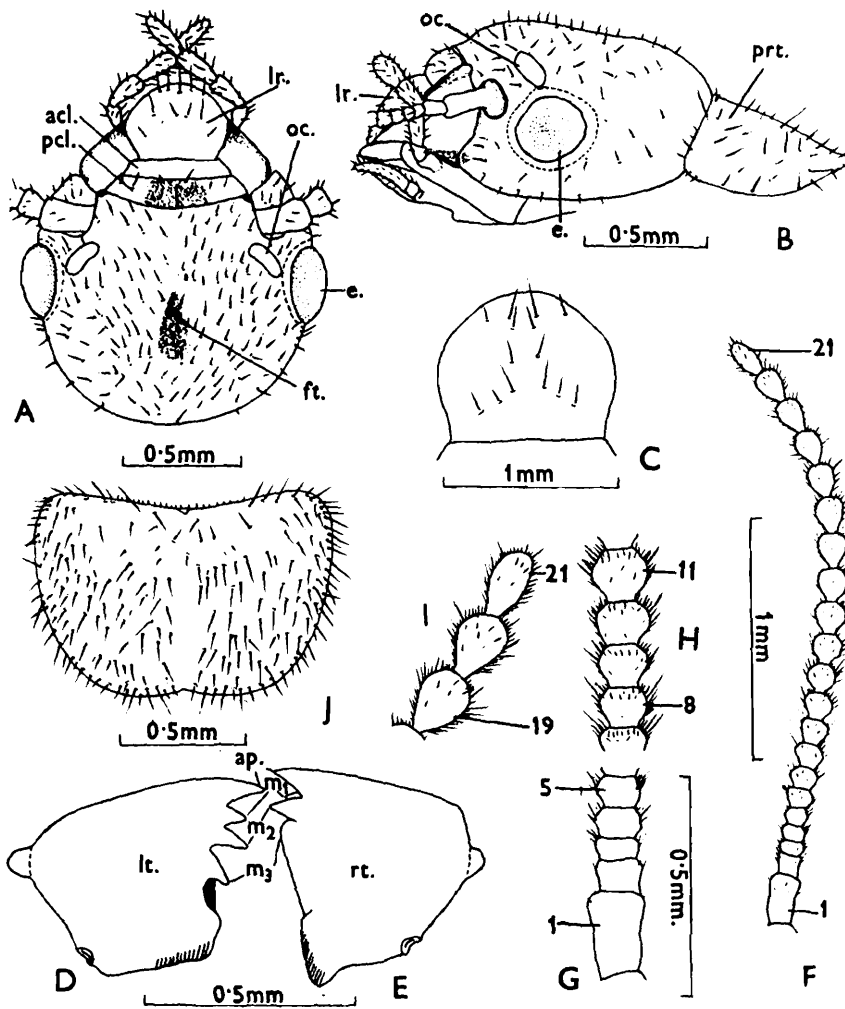

Fig. 238. *Coptotermes heimi*. Imago. (A) Head, in dorsal view. (B) Head and pronotum, in side view. (C) Labrum. (D) Left mandible. (E) Right mandible. (F) Right antenna. (G-I) Portions of antenna, enlarged. (J) Pronotum, in dorsal view. Lettering as in fig. 224 (After Roonwal and Chhotani, 1962b).

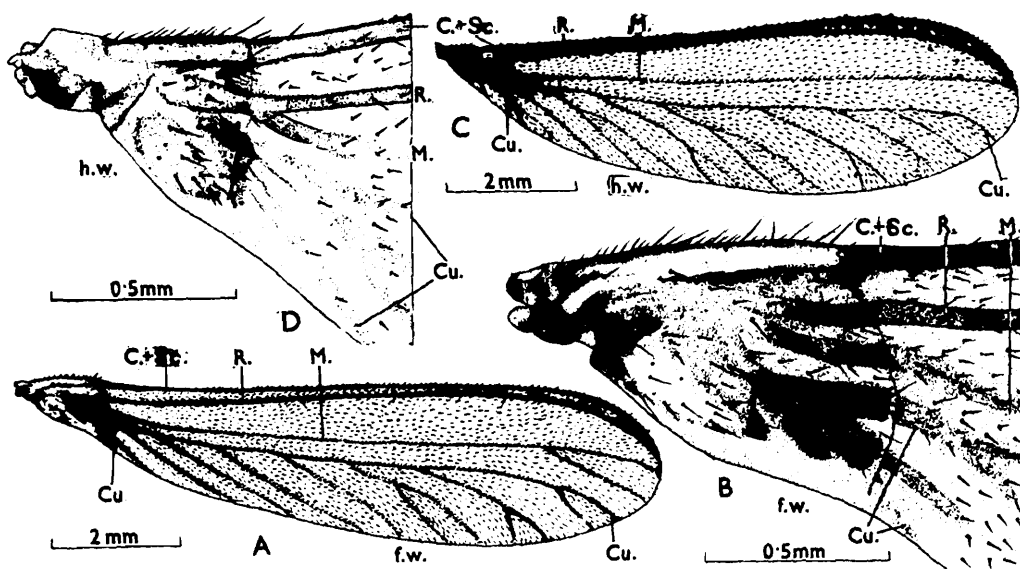

Fig. 239. *Coptotermes heimi*. Wings. (A) Right forewing. (B) Same, scale and proximal part, enlarged. (C) Right hindwing. (D) Same, scale and proximal part, enlarged. Lettering same as in fig. 225 (After Roonwal and Chhotani, 1962b).

onwards gradually increasing in size. Postclypeus yellowish, pilose, weakly swollen, subdivided into right and left halves by an incomplete line; anteclypeus whitish, trapezoidal, apilose. Labrum broadly mushroom-shaped, a little broader than long (width 0.46-0.47, length 0.39-0.41 mm); with a few hairs on body and on anterior margin. Mandibles of *Coptotermes*-type. Pronotum flat, densely pilose, much broader than long (length 0.72-0.81, width 1.21-1.33 mm); narrower than head-width with eyes; anterior margin weakly concave; posterior margin convex with median notch; a pale T-shaped mark on mid-dorsum. Legs with femora long; tibiae long and slender; tibial spurs 3:2:2; tarsi-4 jointed. Wings transparent, densely hairy; venation as in genus in general. Microsculpturing consists of papillae and pimpules; papillae numerous and large, present in 7-9 rows at anterior margin but fewer and smaller on wing scale; pimpules present in proximal one-third of wing-membrane, numerous in distal one-fourth of scale (Roonwal and Rathore 1982). Forewing 8.6-9.75 mm long; media with 2-3 and cubitus with 9-12 branches. Hindwing 8.1-9.6 mm long; media with 2-3 and cubitus with 9-12 branches. Abdomen oblong; styli one-segmented; cerci 2-segmented.

**SOLDIER** (Figs. 240, 241): Very variable. Head-capsule straw yellow to yellowish; fontanelle area paler than rest of head; antennae, legs pronotum and labrum also paler than head; mandibles reddish brown to dark brown; abdomen yellowish white. Head with a few erect bristles and one on each side of fontanelle; pronotum with small setae-like hairs on anterior margin and longer-ones all over; each abdominal tergum with a row of hairs at posterior margin and some scattered ones on body. Total length 4.20-6.00 mm. Head-capsule variable in shape, pyriform to subcircular; generally longer than broad, abnormally as wide as long when subcircular (length to mandible-base 1.20-1.45, width 1.05-1.35 mm; index Width/Length 0.77-1.04); sides converging anteriorly; posterior margin rounded. Fontanelle large, circular, prominent; with a highly sclerotized border. Eyes and Ocelli absent. Antennae with 14-16 segments; segment 3 either smallest or subequal to 2 or 4. Postclypeus and anteclypeus short, trapezoidal. Labrum subtriangular, longer than broad (length 0.28-0.35, width 0.23-0.30 mm); covering a little more than half the length of mandibles; apex hyaline, pointed and with a pair of bristles; a few short setae on body. Mandibles

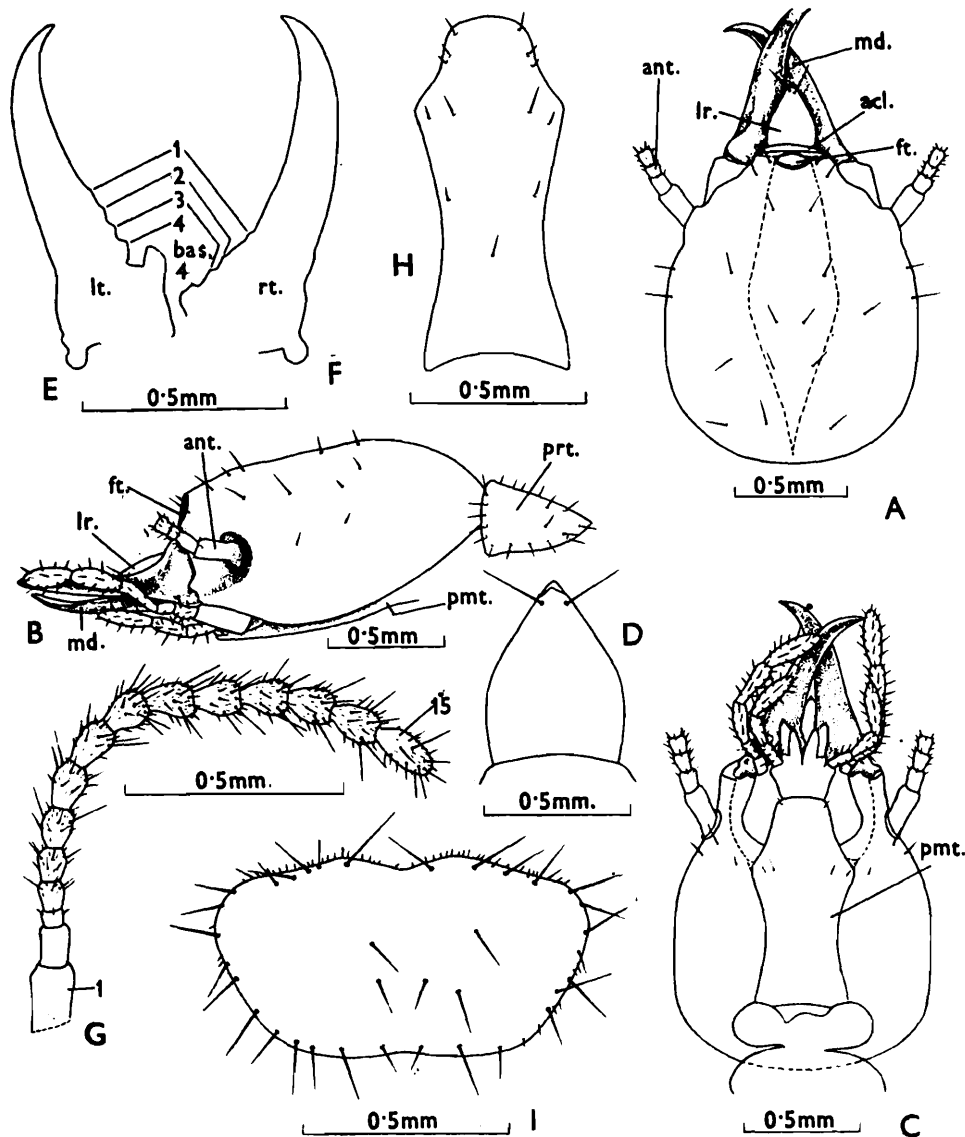

Fig. 240. *Coptotermes heimi*. Soldier. (A) Head, in dorsal view. (B) Head and pronotum, in side view. (C) Head in ventral view, showing postmentum. (D) Labrum. (E) Left mandible. (F) Right mandible. (G) Left antenna. (H) Postmentum. (I) Pronotum, in dorsal view. Lettering same as in fig. 226. (After Roonwal and Chhotani, 1962b).

long (0.70-1.00 mm), sabre-shaped, broad at base and narrowing distally to a sharply pointed, incurved apex. Left mandible with 4 small crenulations and a basal projection in proximal half. Right with 4 small crenulations in proximal one-third. Postmentum generally club-shaped; shape and size variable, depending upon shape of head; with a few hairs on anterior part and body; broadest in anterior one-fourth (0.38-0.45 mm); posteriorly curving to a wide waist (0.25-0.34 mm); anterior margin round; posterior margin concave. Pronotum flat, subreniform, much broader than long (width 0.75-0.95, length 0.40-0.50 mm); anterior margin slightly wavy with

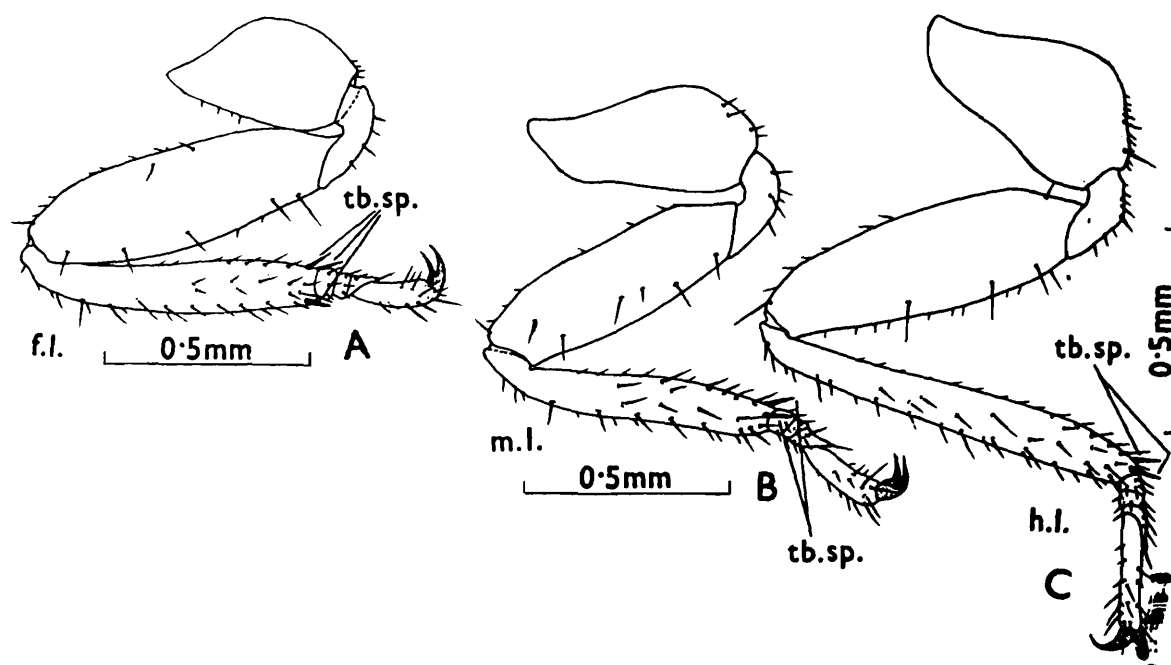

Fig. 241. *Coptotermes heimi*. Soldier legs. (A) foreleg. (B) Middleleg. (C) Hindleg.

f.l., foreleg, h.l., hindleg; m.l., middleleg; tb. sp., tibial spur. (After Roonwal and Chhotani, 1962b).

a medial depression; sides converging to a weakly rounded and medially incurved posterior margin. Legs with femora long and tibiae long and slender; tibial spurs 3:2:2; tarsi 4-jointed. Abdomen oblong, sometimes with two longitudinal rows of brown pigmented bands in middle. Cerci 2-segmented; styli one-segmented.

**WORKER** : Head-capsule pale yellow; antennae, legs, pronotum and abdomen paler. Head densely pilose; abdomen with dense, irregular pilosity. Total length 3.60-5.70 mm. Head-capsule subrounded, broader than long (width 0.88-1.30, length to mandible-base 0.74-1.11 mm). Fontanelle, eyes and ocelli absent. Antennae with 12-15 segments; segment 3 shortest or subequal to either 2 or 4. Clypeus, labrum and mandibles as in imago; labrum width 0.30-0.45, length 0.28-0.40 mm. Pronotum pilose, much broader than long (width 0.51-0.80, length 0.25-0.44 mm); anterior margin wavy with a median depression; posterior margin weakly incurved. Legs and abdomen as in soldier.

**Distribution** : It is a very widely distributed species in the Indian subcontinent, reported from India, Pakistan, Bangladesh, Bhutan and Nepal. Recently introduced in Oman (Chhotani in press).

**Biology** : It is a very common species and does extensive damage to structural timber, woodwork, packing cases, stored materials of cellulosic nature, etc. It is also reported from several plant species and is a serious pest of sugarcane, fruit trees and forestry. Its nests are in soil as well as in dead portions of trees, logs of wood and structural timber in houses and buildings. The nest is a dark greyish, spongy, porous structure made of strands of hard carton fibre and excrement. Swarming is during the months of January to August but generally between March to July (Roonwal 1959, Roonwal and Chhotani 1962b, Chhotani 1980).

#### 68. *Coptotermes kishori* Roonwal and Chhotani (Figs. 242, 243)

*Coptotermes kishori* Roonwal and Chhotani:

1960. Roonwal and Chhotani, *J. zool. Soc. India*, 11(2) : 127. (Nom. nud.)
1962. Roonwal and Chhotani, *Indian Species Termite Genus Coptotermes* (ICAR Ent. Monogr. 2): 9, 57-61, 77, 108-111 (pls. 15, 16); S,W. Holotype: S, in FRI, Dehra Dun. Type-locality: Berhampur (Murshidabad Dist., West Bengal, India).
1962. Roonwal, In *Termites in Humid Tropics* (Proc. New Delhi Symp. 1960) : 40.
1969. Mathur and Chhotani, *J. Timber Dev. Assoc. India*, 15(4): 4.
1975. Sen-Sarma et al. *Wood Destroying Termites of India (Final Tech. Rept. PL-480 Proj.)*: 11, 26, 48, 64.
1979. Sen-Sarma and Thakur, *Indian For Rec. (Ent.) N.S.*, 13(1): 5, 13.
1980. Chhotani, *Tech. Monogr. Zool. Surv. India*, No. 4: 30, 33.
1982. Verma and Thakur, *Rec. zool. Surv. India*, 79: 311-312.
1983. Maiti, *Occ. Pap. Rec. zool. Surv. India*, No. 42: 23, 51-53.
1983. Chhotani, *Orient. Insects*, 17: 117.
1985. Verma, *Indian J. For.*, 8(3): 177-178.

**IMAGO** : Unknown.

**SOLDIER** (Fig. 242) : Head yellow; antennae, labrum, pronotum, legs and abdomen paler than head; mandibles dark brown, basally yellow. Head

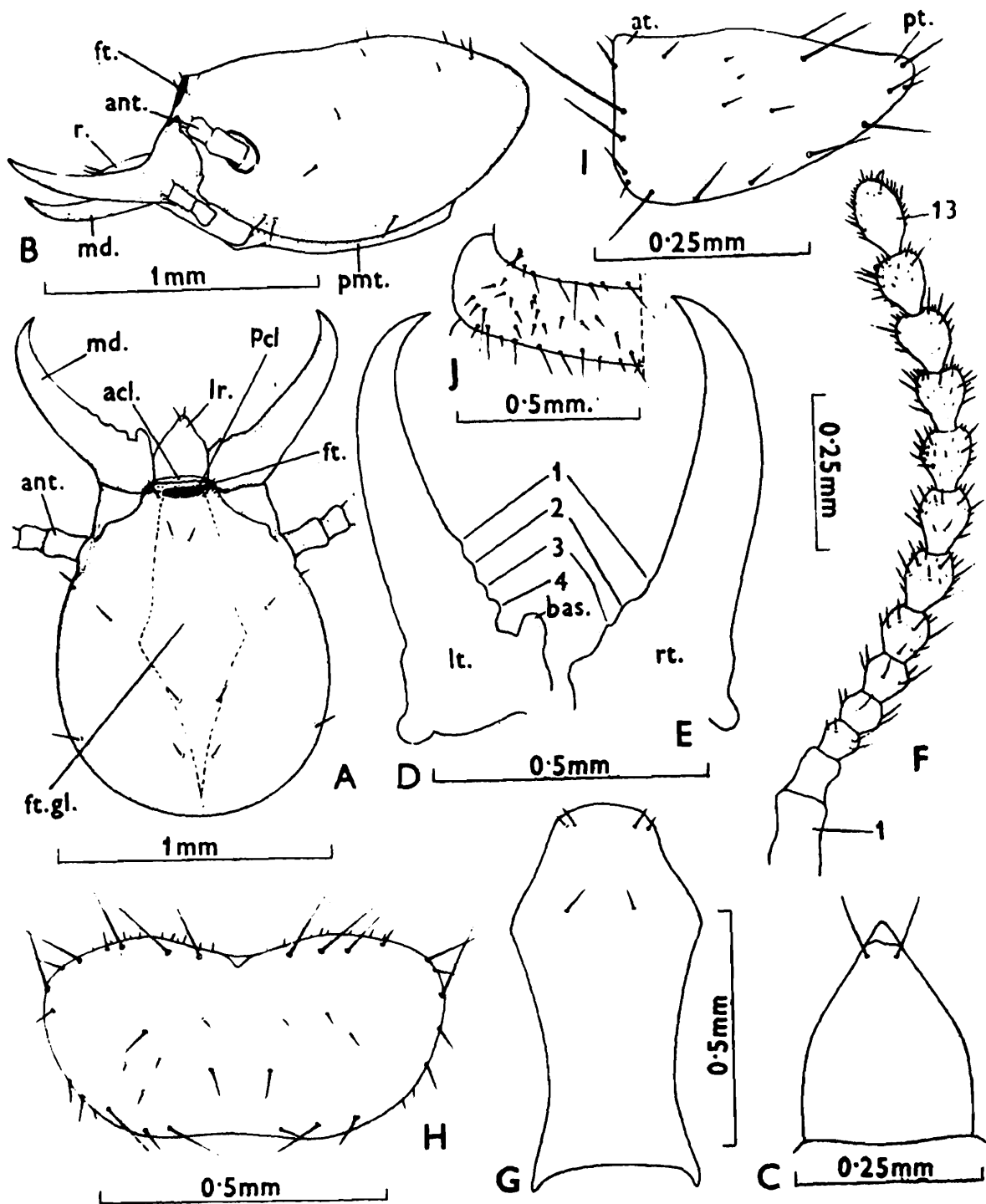
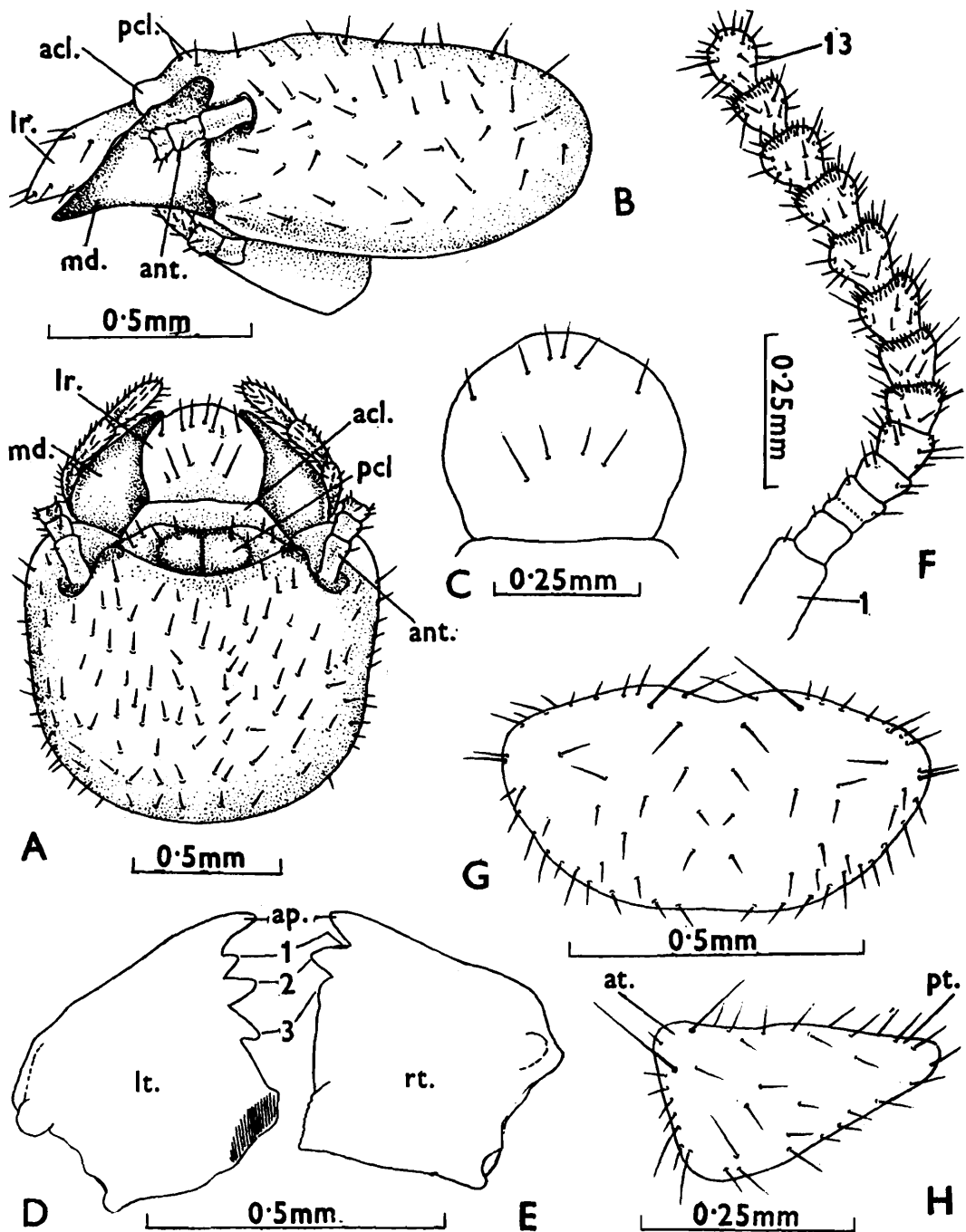

Fig. 242. *Coptotermes kishori*. Soldier. (A) Head, in dorsal view. (B) Same, in side view. (C) Labrum. (D) Left mandible. (E) Right mandible. (F) Right antenna. (G) Postmentum. (H) Pronotum, in dorsal view. (I) Same, in side view. (J) Left half of 2nd abdominal tergum, showing arrangement of hairs. Lettering same as in fig. 226 (After Roonwal and Chhotani, 1962b).

sparsely hairy with one hair on either side of fontanelle; pronotum fairly pilose with long hairs; abdominal terga each with a posterior row of hairs and a few on body. Total length 3.75-4.8 mm. Head oval, longer than broad (length to base of mandibles 1.13-1.25, width 0.95-1.08 mm); narrowed anteriorly; posterior margin rounded; head a little elevated in between antennae, depressed in middle and again raised a little posteriorly so that in profile it appears wavy in outline. Fontanelle opening circular, ring-like and chitinized. Eyes and ocelli absent. Antenna with 13-14 segments, segment 3 smallest or subequal to or longer than 2 or 4. Postclypeus and anteclypeus narrow, trapezoidal. Labrum subtriangular, little longer than broad (length 0.20-0.28, width 0.20-0.25 mm); subparallel sided; apex hyaline, pointed, with a long bristle on either side of tip. Mandibles long (0.73-0.83 mm), sabre-shaped; incurved and sharp at tip. Left mandible with 4 crenulations and a basal projection in proximal half of inner margin; right with 3 crenulations in proximal one-third of inner margin. Postmentum long (0.70-0.80 mm), broadly vase-shaped, broadest in anterior one-third (maximum width 0.35-0.38 mm); anteriorly narrowing slightly to a convex anterior margin, posteriorly to a broad waist (waist-width 0.23-0.25 mm) and curving out to a broader concave posterior margin. Pronotum broader than long (length 0.35-0.40, width 0.65-0.73 mm); narrower than head; anterior margin weakly convex, with a medial, obtuse concavity; sides slightly converging to a somewhat convex and weakly, medially incurved posterior margin. Legs with long femora, long and slender tibiae; tibial spurs 3:2:2. Abdominal terga each with a row of hairs at posterior margin and dense, irregular pilosity on body; styli one-segmented; cerci 2-segmented.

**WORKER** (Fig. 243) : Head-capsule and mandibles pale yellow; antennae, labrum, pronotum and abdomen paler than head. Head moderately and pronotum and abdomen densely and irregularly pilose. Total length 3.60-4.28 mm. Head-capsule squarish, broader than long (length to mandible-base 0.80-0.88, width 1.0-1.08 mm); sides converging slightly to a rounded posterior margin. Fontanelle, eyes and ocelli absent. Antennae with 13-14 segments; segment 3 shortest or subequal to 2 or 4. Postclypeus sparsely pilose, swollen; anteclypeus narrow, apilose, trapezoidal. Labrum broadly tongue-shaped, a little broader than long



**Fig. 243.** *Coptotermes kishori*. Worker. (A) Head in dorsal view. (B) Same, in side view. (C) Labrum. (D) Left mandible. (E) Right mandible. (F) Right antenna. (G) Pronotum, in dorsal view. (H) Same, in side view. Lettering same as in fig. 228. (After Roonwal and Chhotani, 1962b).

(length 0.35-0.38, width 0.38-0.40 mm); anterior margin rounded and with a few hairs on margin and on body. Mandibles of *Coptotermes*-type. Pronotum much broader than long (length 0.30-0.38, width 0.60-0.68 mm); anterior margin slightly projected in front and with a deep, obtuse, median incurving; posterior margin substraight. Legs as in soldier. Abdomen oblong, densely pilose; cerci and styli as in soldier.

*Distribution* : INDIA : West Bengal : Berhampur (Murshidabad Dist., type-locality) and Kalyani (Nadia Dist.); Tripura; Rajasthan; Madhya Pradesh; Kerala.

### 69. *Coptotermes travians* Haviland (Figs. 244-247)

#### 1. *Termes* (*Coptotermes*) *travians* Haviland :

1898. Haviland, *J. Linn. Soc. Lond. (Zool.)*, 26(164): 391-392; Pl. 23 (figs. 19-22). Im, S, W. Holotype : Not selected. Syntypes in BM, London; AMNH, New York; FRI, Dehra Dun; IARI, New Delhi. Also probably in Zoology Mus., Cambridge (U.K.) and Holmgren Coll., National Mus., Stockholm. Type-localities: Singapore and Sarawak (Malaysia).

1904. Desneux, *Genera Insectorum*, Fasc. 25: 34.

#### 2. *Coptotermes travians* Haviland :

1911. Holmgren, *Zool. Anz.*, 37: 551-552.

1913. Holmgren, *K. Sv. Vet. Akad. Handl.*, 50(2): 72-73; Pl. 2 (Fig. 7). Im, S, W.

1917. Holmgren and Holmgren, *Mem. Dept. Agric. India (Ent.)*, 5(3): 145.

1925. John, *Treubia*, 6(3-4): 381.

1934. Kemner, *K. Sv. Vet. Akad. Handl.*, (3) 13(4): 62-64. Im, S, W.

1949. Snyder, *Smiths. misc. Colls.*, 112: 83.

1953. Rattan Lal and Menon, *Catal. Indian Insects Pt. 27, Isoptera* : 27.

1956. Roonwal and Sen-Sarma, *Indian J. Agric. Sci.*, 26(1): 2, 4.

1958. Ahmad, *Biologia, Lahore*, 4(1-2): 62, 67.

1962. Roonwal and Chhotani, *Indian Species Genus Coptotermes* (ICAR Ent. Monogr. 2): 8, 9, 61-69, 72, 76, 112-115 (pls. 17, 18), Im, S, W. (See for detailed synonymy, description, distribution, etc.)

1962. Roonwal and Chhotani, *Proc. natn. Inst. Sci. India*, (B) 28(4): 295, 309-310, 394.

1965. Roonwal and Chhotani, *J. Bombay nat. Hist. Soc.*, 62(1): 22, 23.

1966. Roonwal and Maiti, *Treubia*, 27(1): 71, 82-84.

1970. Roonwal and Bose, *Rec. zool. Surv. India*, 62(3-4): 111, 117, 119, 123-124, 165, 166.
1970. Roonwal, In *Biology of Termites* vol. 2(Eds. Krishna and Weesner) : 339.
1972. Chaudhry and Ahmad, *Termites of Pakistan (Final Tech. Rept. PL-480 Proj.)*: 17.
1975. Sen-Sarma et al., *Wood Destroying Termites of India (Final Tech. Rept. PL-480)*: 11, 48, 64.
1975. Akhtar, *Bull. Dept. Zool. Panjab Univ., Lahore, (N.S.)*, Art. 7: 36, 42-43, 185, 191.
1977. Maiti, *Proc. zool. Soc., Calcutta*, 30: 133.
1979. Sen-Sarma and Thakur, *Indian For. Rec. (N.S.) Ent.*, 13(1): 5, 13-14.
1980. Bose, *Rec. zool. Surv. India*, 77: 99.
1982. Bose and Das, *Rec. zool. Surv. India*, 80: 199.
1983. Maiti, *Occ. Pap. Rec. zool. Surv. India*, No. 42: 17, 23, 53-54, Map 1.
1983. Chhotani, *Orient. Insects*, 17: 117.
1985. Chhotani, *Z. ang. Ent.*, 100: 91.
1986. Grassé, *Termitologia* Vol. 3: 119.
1987. Bose and Das, *Fauna of Orissa: State Fauna Series*, No. 1: 104, 108.

**IMAGO (Figs. 244, 245) :** Head-capsule reddish-brown, somewhat paler behind postclypeus; pronotum and abdominal tergites pale brown; postclypeus, antennae, labrum and legs pale brownish yellow; wings transparent, pale brownish. Head and body fairly densely hairy; wings densely pilose with small hairs. Total length with wings 11.5-13.30, without wings 6.4-9.0 mm. Head-capsule subcircular; length to base of mandibles 1.10-1.15, width with eyes 1.18-1.45 mm; with a faint, paler, subreniform mark in front of ocelli; Y-suture indistinct. Fontanelle minute, circular, situated medially; slightly raised; dorsum around fontanelle depressed. Eyes black, subcircular, maximum diameter 0.35-0.38 mm. Ocelli oval (maximum diameter 0.175-0.19, minimum diameter 0.13-0.15 mm); situated very close to eyes (eye-ocellar distance 0.03 mm) or touching eyes. Antennae with 19-23 segments; segment 3 or 4 shortest. Postclypeus slightly raised; shorter than half of width; pilose; with a median line separating it into right and left halves. Anteclypeus apilose, hyaline, trapezoidal. Labrum dome-shaped, pilose; width 0.4-0.43, length 0.3-0.38 mm. Mandibles of typically *Coptotermes*-type. Pronotum flat, subreniform; anterior margin weakly

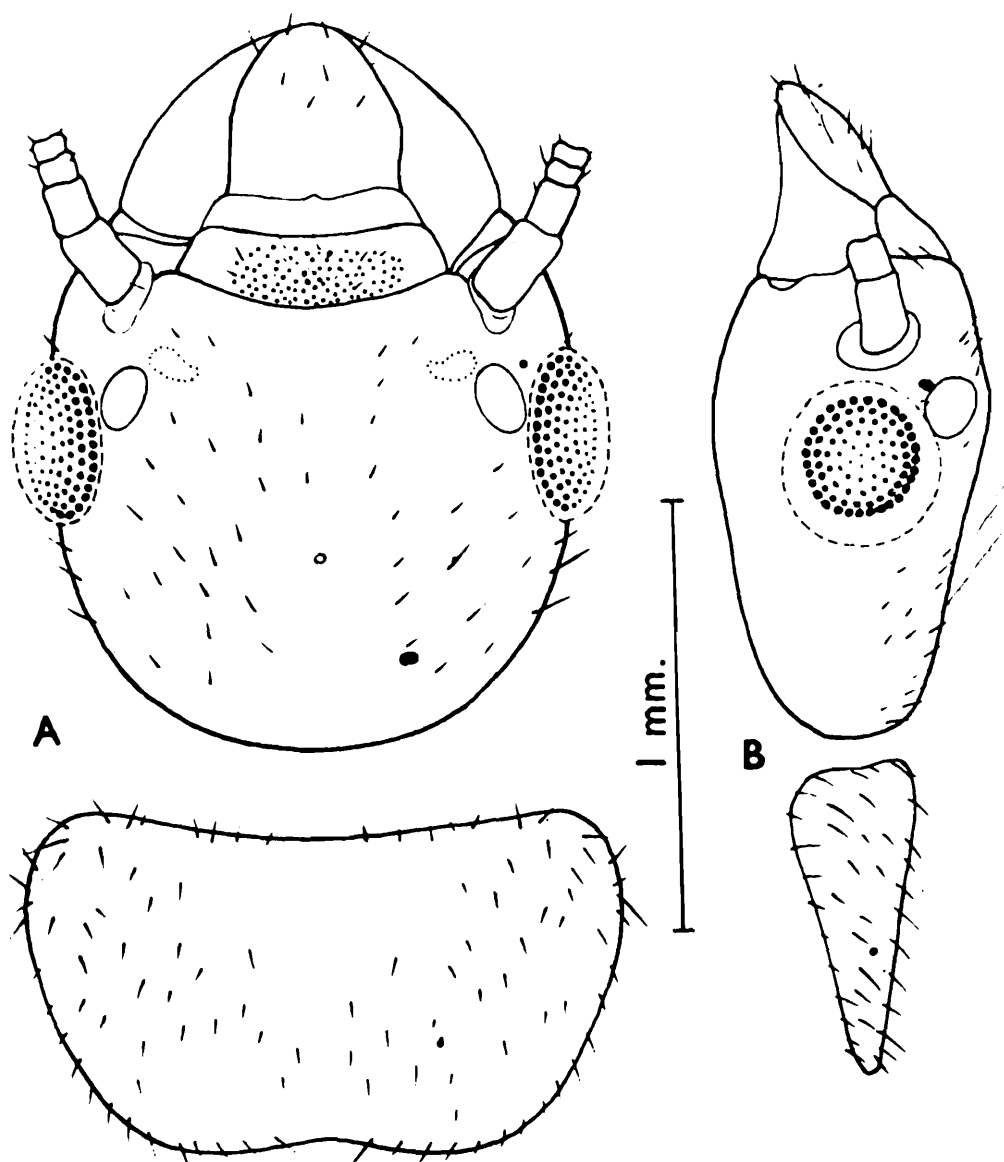

Fig. 244. *Coptotermes travians*. Imago. (A) Head and pronotum, dorsal view. (B) Same, side view.

incurved and faintly or not notched in middle; sides rounded; posterior margin weakly invaginated medially; length 0.61-0.83, width 1.06-1.38 mm. Wings profusely hairy with minute hairs all over; venation as in genus in general, cubitus with 10-12 branches in forewing, 10 in hindwing; forewing 10.0-10.5 and hindwing 9.5-10 mm long. Legs with 3:2:2 tibial spurs and 4-jointed tarsi. Abdomen elongate, cerci 2-jointed, 0.13 mm long; styli in male single jointed, 0.10 mm long.

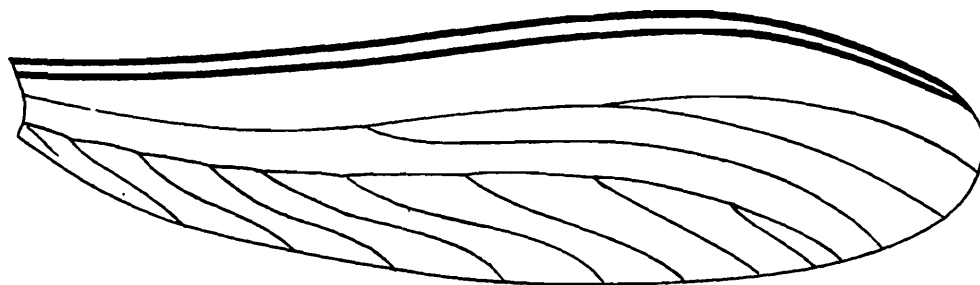

Fig. 245. *Coptotermes travians*. Forewing. (After Haviland 1898).

**SOLDIER (Fig. 246) :** Head-capsule yellow, fontanelle area paler; antennae, labrum, pronotum, legs and abdomen paler than head; mandibles dark brown. Head with a few, erect, scattered bristles and a long one on either side of fontanelle; pronotum with short hairs on anterior margin and longer hairs on margins and body; abdominal tergites each with a row of setae on posterior margin and irregular ones on body. Total length 4.0-4.92 mm. Head-capsule oval, longer than broad (length to mandible-base 1.23-1.40, width 1.00-1.18 mm); dorsum of head swollen behind fontanelle; sides slightly convex, converging anteriorly; posterior margin convex. Fontanelle opening large, circular, with chitinous border. Eyes and ocelli absent. Antennae with 14-15 segments; segment 3 either shortest or subequal to or longer than 2 or 4. Postclypeus yellow, with a few hairs, narrow, hardly separable from frons; anteclypeus hyaline, trapezoidal, apilose, narrow strip. Labrum subtriangular, a little longer than broad (length 0.25-0.34, width 0.25-0.30 mm); sides weakly swollen, strongly converging to a pointed, hyaline tip; with one long bristle on either side of tip. Mandibles sabre-shaped, basally broad, narrowing anteriorly to a sharply pointed, incurved apex; length 0.75-0.88 mm. Left mandible with 4 crenulations and a basal projection in basal half and right mandible with much weaker 3 or 4 crenulations in basal one-third. Postmentum club-shaped, broadest in anterior one-third; sides narrowing posteriorly to a broad waist and again widening out to a concave posterior margin (length

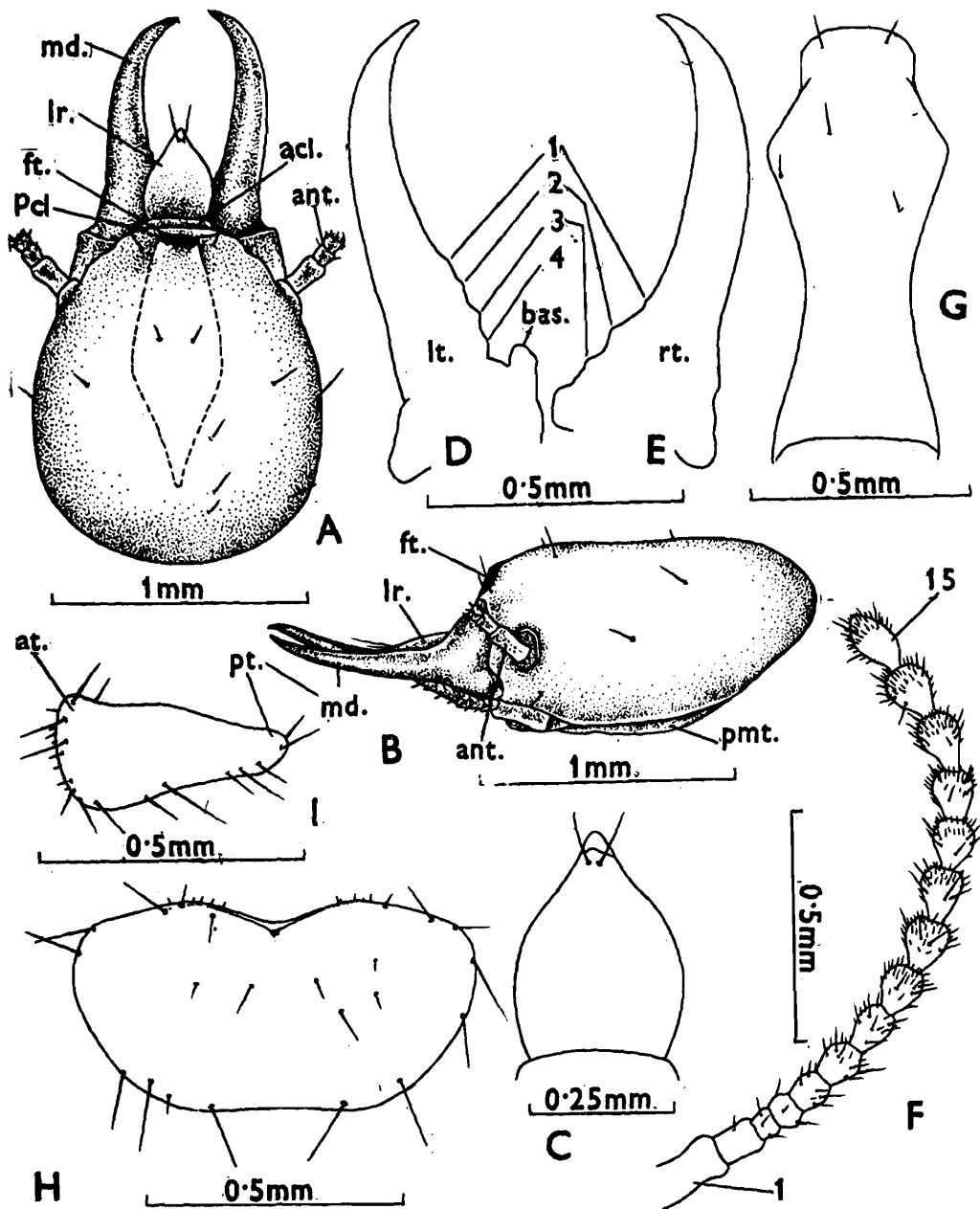

Fig. 246. *Coptotermes travians*. Soldier. (A) Head, in dorsal view. (B) Same, in side view. (C) Labrum. (D) Left mandible. (E) Right mandible. (F) Right antenna. (G) Postmentum. (H) Pronotum, in dorsal view. (I) Same, in side view. Lettering same as in fig. 226 (After Roonwal and Chhotani, 1962b).

0.78-1.0, max. width 0.34-0.44, width at waist 0.23-0.29 mm). Pronotum flat, subreniform much broader than long (width 0.68-0.88, length 0.35-0.44 mm); narrower than head; anterior margin convex with obtuse median

notch; posterior margin very weakly incurved medially. Legs long slender; tibial spurs 3:2:2; tarsi 4-jointed. Abdomen oblong; cerci 2-segmented; styli one-segmented.

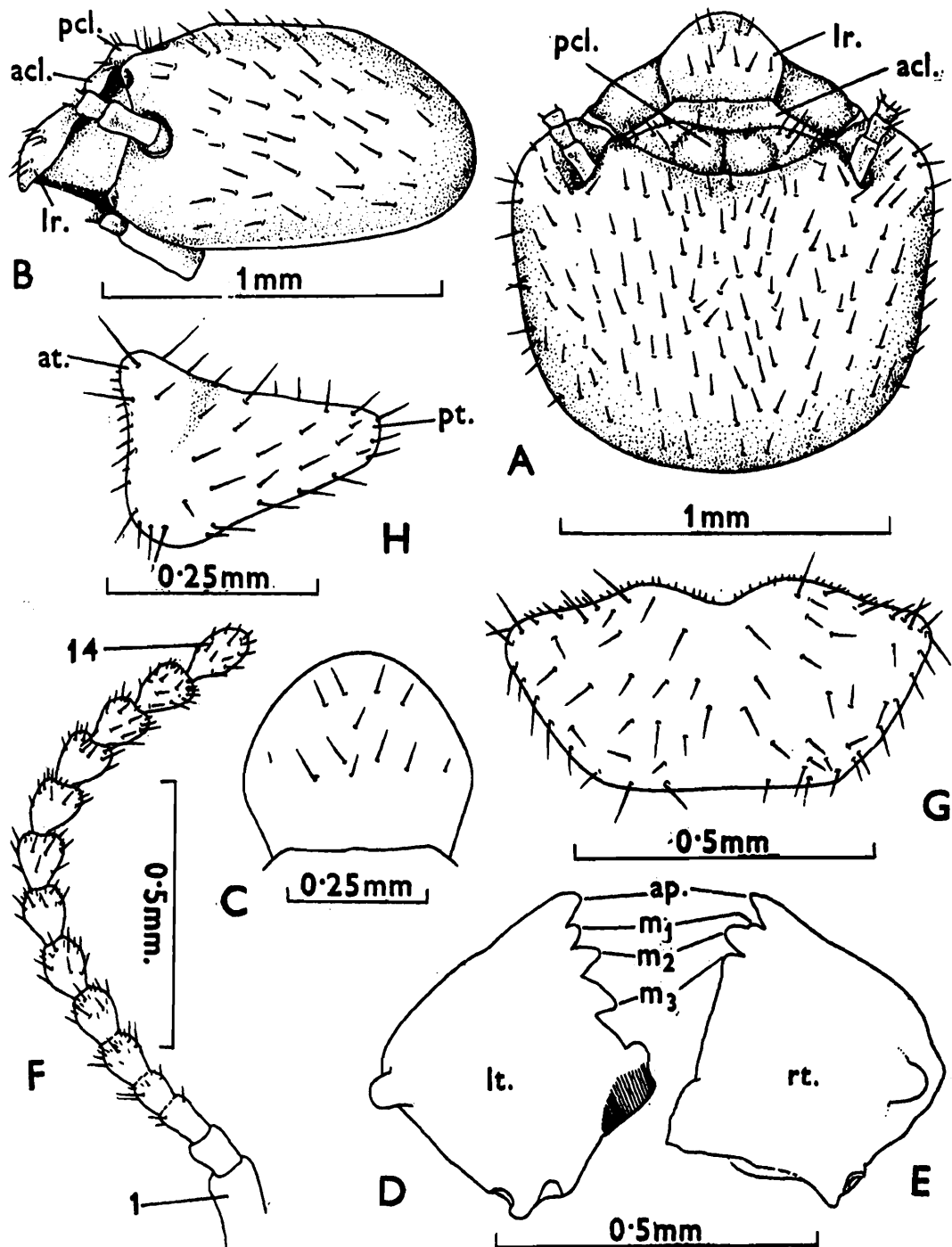

Fig. 247. *Coptotermes travians*. Worker. (A) Head, in dorsal view. (B) Same, in side view. (C) Labrum. (D) Left mandible. (E) Right mandible. (F) Left antenna. (G) Pronotum, in dorsal view. (H) Same, in side view. Lettering same as fig. 228 (After Roonwal and Chhotani, 1962b).

**WORKER** (Fig. 247) : Head-capsule pale yellow; antennae, labrum, pronotum, legs and abdomen paler. Head and pronotum moderately and abdomen densely pilose. Total length 4.00-4.75 mm. Head-capsule subcircular, broader than long, broadest anteriorly (width 1.10-1.23 mm, length to mandible-base 0.98-1.00 mm). Fontanelle, eyes and ocelli absent. Antennae with 13-14 segments. Postclypeus somewhat swollen; anteclypeus flat, trapezoidal, translucent strip. Labrum broader than long (width 0.35-0.43, length 0.33-0.38 mm). Mandibles of *Coptotermes*-type. Pronotum flat, with anterior margin deeply notched medially and sometimes weakly upturned; much broader than long (length 0.29-0.38, width 0.64-0.75 mm); posterior margin substraight. Legs and abdomen as in soldier.

**Distribution** : INDIA : Assam (Margherita, Lakhimpur), West Bengal (Calcutta), Orissa (Puri), Andaman and Nicobar Isls., BANGLADESH : Chaumahani (Noakhali dist.), Sripur. BURMA : Akyab, Kyaukpya, Pokoku, Pyu, Sandoway and Wapyudaung. Also MALAYASIA, SINGAPORE and INDONESIA (Java, Sumatra, Sulawesi). For details vide Roonwal and Chhotani, 1962b.

**Biology** : The nests of this species are made in underground parts of wooden stumps, posts, etc. but may also be found above ground in timber and wooden ships. The species has also been reported to attack wood in store-yards and buildings and many species of trees. The imagoes have been found in the months of January, February, August and October (Roonwal, 1970a).

### Subfamily (iii) HETEROTERMITINAE Froggatt

**Synonyms** : Leucotermitinae Holmgren and Glyptotermitinae Froggatt (part)

#### 1. Subfamily Heterotermitinae Froggatt :

1896. Froggatt, *Proc. Linn. Soc. N.S.W.*, 21: 550.

1934. Kemner, *K. Sv. Vet. Akad. Handl.*, (3) 13(4): 67.

1955. Weidner, In *Die Termiten* (Ed. H. Schmidt): 55, 69.

1960. Weidner, *Abh. Ver. naturw. Ver. Hamburg*, 4: 57.

1970. Krishna, In *Biology of Termites* (Eds. Krishna and Weesner) Vol. 2: 137, 138.

1970. Weidner. *Handb. d. Zool.*, 4(2): 21.
1971. Emerson, *Bull. Am. Mus. nat. Hist.*, 146(Art. 3): 272.
1974. Sen-Sarma, In *Ecology and Biogeography in India* (Ed. M.S. Mani): 452.
1977. Chhotani, *Proc. 8th int. Congr. Int. Un. Study Social Insects* (Wageningen, Sept. 1977): 116-117.
1979. Roonwal, *Termites Life & Termite Contr. Trop. South Asia* : 79, 117.
1982. Grassé, *Termitologia* Vol. 1: 86-87.
1983. Chhotani, *Oriental Insects*, 17: 111, 112.
1984. Bose, *Occ. Pap. Rec. zool. Surv. India*, No. 49: 77.
1985. Chhotani, *Z. ang. Ent.*, 100: 91, 92, 93.
1986. Grassé, *Termitologia* Vol. 3: 519.

2. Subfamily Leucotermitinae (of Mesotermitidae) Holmgren :

1910. Holmgren, *Trans. Linn. Soc. London*, 14: 143.
1911. Holmgren, *K. Sv. Vet. Akad. Handl.*, 46(6): 68.
1913. Holmgren, *K. Sv. Vet. Akad. Handl.*, 50(2): 14, 60.
1925. Sjöstedt. *K. Sv. Vet. Akad. Handl.*, (3) 3 (1): 59.

3. Subfamily Glyptotermitinae Froggatt (Part) :

1896. Froggatt, *Proc. Linn. Soc. N.S.W.*, 21: 518.

Type genus : *Heterotermes* Froggatt.

1. Characters of Subfamily Heterotermitinae

*Imago* : Head-capsule oval or subsquarish; epicranial suture absent or very faint. Fontanelle minute, situated medially. Eyes small, oval or subcircular. Ocelli absent or dot-like. Antennae 12-19 segmented. Postclypeus weakly swollen; shorter than half of width. Mandibles each with an apical and three marginals. Left mandible: Apical finger-like; 1st marginal either equal to or a little smaller than apical; 2nd as long as apical; 3 small with long anterior margin. Right mandible: Apical finger-like as in left; 1st marginal rudimentary, situated at base of 2nd marginal; 2nd subequal to apical; 3rd small with long posterior margin; molar plate shorter than posterior margin of 3rd marginal. Pronotum flat, narrower than head. Wings slender, colourless or faint yellow; weakly hairy; microsculpturing consists of papillae and pimpules (*Reticulitermes*) and papillae and asteroid

and non-asteroid micrasters (*Heterotermes*), for details see 'Note' below; costa and radius thick and running parallel to each other near anterior margin; media weak, arising separately from scale in forewing and from radius just outside scale in hindwing, and running medially; cubitus also weak and giving off 8-12 branches to posterior margin. Legs thin and long; apical tibial spurs 3:2:2; tarsi 4-jointed. Abdomen elongate, hairy; cerci 2-jointed; styli single-jointed.

*Note on wing microsculpturing* : Wings moderately hairy specially on anterior veins. Both surfaces densely covered with 2 types of microsculpturing elements namely papillae and micrasters (*Heterotermes*) or papillae and pimpules (*Reticulitermes*). In *Heterotermes* papillae are present in 3-4 rows at anterior margin (density 5400-8200/mm<sup>2</sup>); may be of two types, e.g. finger-like or tongue-shaped (*Heterotermes gertrudae*) or spiky and pointed (*H. indicola*). Micrasters (both asteroid and non-asteroid) present all over the wing membrane in considerable density (4000-5330/mm<sup>2</sup>). In *Reticulitermes* papillae are in 2-4 rows on front vein and numerous, glossy, rounded minute pimpules (density 7000/mm<sup>2</sup>). (Roonwal and Verma 1976; Roonwal and Rathore 1977, 1982; Roonwal, Verma and Thakur 1979; Roonwal 1981a, 1983c, 1985a, b SEM study).

*Soldier* : Monomorphic (*Reticulitermes* and some *Heterotermes*) or dimorphic (some *Heterotermes*). Head-capsule subrectangular; sides subparallel; frons sloping in front; frontal area, just before sloping, either raised forming frontal protuberances one on either side or with no such protuberances. Antennae with 12-19 segments. Labrum triangular, tip sometimes needle-like (some *Heterotermes*\*). Postclypeus faintly demarcated from frons. Mandibles long; sabre-shaped, slightly incurved near apex; without any teeth, left with a few (3-4) crenulations in basal half. Postmentum club-shaped. Pronotum flat; anterior margin weakly to deeply notched medially. Legs slender; apical tibial spurs 3:2:2; tarsi 4-jointed.

*Worker* : Monomorphic or dimorphic. Pale yellowish in colour. Head subsquarish. Fontanelle indistinct. Eyes and ocelli absent. Antennae 12-18

---

\* See note on soldier of *Heterotermes*, p. 480.

segmented. Postclypeus weakly swollen; length less than half of width. Mandibles as in imago. Pronotum flat; anterior margin weakly to deeply notched medially. Legs and abdomen as in soldier.

### 2. *Distribution and Composition of Heterotermitinae*

*Distribution* : The subfamily is reported from all the zoogeographical regions; the genus *Heterotermes* is generally confined to tropical and the *Reticulitermes* and *Tsaitermes* to the temperate, parts. Some species of *Heterotermes* and *Reticulitermes*, however, extend and overlap in distribution to adjacent parts.

*Composition* : The subfamily comprises the genera *Heterotermes*, *Reticulitermes* and *Tsaitermes*. Of these, the first two occur in the Indian Region limits. The third one i.e., *Tsaitermes*, which has recently been described by Li and Ping 1983, is known by some species earlier reported under the genus *Reticulitermes* and a few described as new. We have examined the species *hunanensis* Li and Ping and *oocephalus* (Ping and Li), of this genus, very kindly received through the courtesy of Prof. Ping and find them very near *Reticulitermes* except for some minor characters. In our opinion, all the *Reticulitermes* species from China need a thorough study.

### 3. *Keys to the Indian Region Genera of Heterotermitinae*

#### IMAGOES

Generally paler species. Second marginal tooth of left mandible distinctly longer than first .....	<i>Heterotermes</i>
Generally darker species. Second marginal tooth of left mandible nearly as long as first .....	<i>Reticulitermes</i>

#### SOLDIERS

The species of the genera *Heterotermes* and *Reticulitermes* known from the Indian Region can be separated as follows :—

Labrum tongue-shaped, tip sometimes slightly pointed .....	<i>Reticulitermes</i>
Labrum with needle-like tip .....	<i>Heterotermes</i>

**Genus 15. *Heterotermes* Froggatt**  
(Synonyms : *Leucotermes* Silvestri, *Psalidotermes* Silvestri)

1. *Heterotermes* Froggatt :

1896. Froggatt, *Proc. Linn. Soc. N.S.W.*, 21: 518, 550.
1934. Kemner, K. *Sv. Vet. Akad. Handl.*, 13(4): 67-68.
1942. Hill, *Termites (Isoptera) Australian Region* : 8, 11, 14, 120.
1949. Snyder, *Smiths. misc. Colls.*, 112: 56.
1953. Rattan Lal and Menon, *Catal. Indian Insects, Part 27, Isoptera* : 29.
1955. Emerson, *Fieldiana: Zool.*, 37: 472, 473, 477, 478, 479, 483, 484, 490, 493, 499, 509.
1955. Ahmad, *Biologia*, Lahore, 1: 219, 220.
1958. Ahmad, *Biologia*, Lahore, 4: 58, 59, 68-70.
1961. Harris, *Termites : Recognition & Control*: 46, 89. (2nd Ed. 1971).
1964. Roonwal and Bose, *Zoologica*, 40(113): 8.
1970. Krishna, In *Biology of Termites* (Eds. Krishna and Weesner) Vol. 2: 137.
1970. Roonwal, In *Biology of Termites* (Eds. Krishna and Weesner) Vol. 2: 332-334.
1971. Emerson, *Bull. Am. Mus. nat. Hist.*, 146(Art. 3): 248, 250, 251, 256, 257, 258, 259, 272-274, 298.
1975. Sen-Sarma et al., *Wood Destroying Termites of India* (Final Tech. Rep. PL 480 Proj.) : 7, 11.
1977. Roonwal and Rathore, *Zool. Anz.*, 198: 299, 308, 311.
1977. Chhotani, *Proc. 8th int. Cong. Int. Un. Study Social Insects* (Wageningen, Sept. 1977): 116, 117.
1977. Mathews, *Studies Termites from Mato Grasso State, Brazil* : 83.
1979. Roonwal, Verma and Thakur, *Proc. Indian. natn. Sci. Acad.*, (B) 45(4): 333, 349.
1979. Thakur and Sen-Sarma, *Indian For. Rec. (N.S.) Ent.*, 13(2): 1-4.
1980. Chhotani, *Tech. Monog. Zool. Surv. India*, No. 4: 5, 26.
1982. Bose and Das, *Rec. zool. Surv. India*, 80: 199.
1983. Tsai and Huang, *Acta Ent. Sinica*, 26: 43.
1983. Maiti, *Occ. Pap. Rec. zool. Surv. India*, No. 42: 17, 22.
1983. Roonwal, *Proc. Indian natn. Sci. Acad.*, (B) 49(5): 363.
1983. Chhotani, *Oriental Insects*, 17: 111, 112, 114, 115, 118.
1984. Bose, *Occ. Pap. Rec. zool. Surv. India*, No. 49: 77, 78.

1985. Chhotani, *Z. ang. Ent.*, **100**: 91, 92, 93, 94.

1986. Grassé, *Termitologia* Vol. 3: 522.

2. *Termes* (*Eutermes*) in part :

1858. Hagen, *Linn. Ent.*, **12**: 108, 186.

3. *Termes* Linn. (Part) :

1897. Froggatt, *Proc. Linn. Soc. N.S.W.*, **22**: 721.

1898. Haviland, *J. Linn. Soc. London*, **26**(169): 378, 398. (Section with *Termes tenuis* for type)

1900. Sjöstedt, *K. Sv. Vet. Akad. Handl.*, **34**(4): 19-21.

4. *Leucotermes* Silvestri :

1901. Silvestri, *Bull Mus. Zool. Anat. Comp.*, **16**(389) : 3.

1911. Holmgren, *K. Sv. Vet. Akad. Handl.*, **46**(6): 62, 69.

1913. Holmgren, *K. Sv. Vet. Akad. Handl.*, **50**(2): 60, 63.

1926. Sjöstedt, *K. Sv. Vet. Akad. Handl.*, (3) **3**(1): 59.

5. Subgenus *Leucotermes* of *Termes* :

1904. Desneux, In Wytman's *Genera Insect.*, Fasc. **25**: 29, 31, 32-33.

6. *Psalidotermes* Silvestri :

1909. Silvestri, In Michaelsen's and Hartmeyer's *Die Fauna Südwest-Austral.* Vol. **2**: 296. Type of genus: *Termes ferox* Froggatt.

1911. Holmgren, *K. Sv. Vet. Akad. Handl.*, **46**(6): 69, 71.

See Hill 1942, Snyder 1949 and Thakur and Sen-Sarma 1979 also for synonymy.

Type of genus : *Heterotermes platycephalus* Froggatt.

### 1. Characters of Genus *Heterotermes*

**Imago** : Generally paler species, pale yellow to light brown; fairly densely hairy. Head-capsule subsquarish, almost as long as wide; sides without eyes substraight; epicranial sutures absent. Fontanelle small; situated at mid-dorsum of head. Eyes oval, medium sized, weakly projecting. Ocelli when present small, dot-like or absent. Antennae with 13-19 segments. Postclypeus weakly swollen, length less than half of width, pilose. Anteclypeus hyaline, apilose. Mandibles each with an apical and three marginals. Left mandible: Apical finger-like, 1st marginal a little smaller than apical, 2nd as long as apical, 3rd small with long anterior

margin. Right mandible: Apical finger-like as in left, 1st marginal small rudimentary tooth, lying at anterior base of 2nd marginal, 2nd triangular, 3rd short but with a long posterior margin. Pronotum narrower than head-capsule, trapezoidal; anterior margin straight or weakly incurved. Legs thin and long; apical tibial spurs 3:2:2; tarsi 4-jointed. Wings slender, faintly yellowish or colourless and transparent, membrane covered with papillae and both asteroid and non-asteroid micrasters and hairs, hairs present on anterior veins and few on membrane and other veins. Forewing: Costa (subcosta + radius of some authors) thick, running along anterior margin; radius (radial sector of some authors) as thick as costa and running parallel with and close to it; media running medially, branched in distal half, arising independently from scale; cubitus arising independently and giving 10-11 branches to posterior margin. Hindwing: Costa and radius as in forewing; media separating from radius just outside scale, otherwise as in forewing; cubitus with 9-11 branches to posterior margin. Abdomen elongate, thickly hairy. Cerci 2-jointed; styli (in male) single-jointed.

*Soldier*: Two types of soldiers i.e. major and minor are reported in some species of this genus, the difference between the two types is in size only. However, the size shows an intraspecific variation in *H. indicola* (Wasmann) as pointed out by Chhotani and Das (1979).

Head-capsule pale yellowish to pale brownish; body creamish white; head moderately and body fairly densely hairy. Head-capsule subrectangular, longer than wide; sides subparallel, posterior margin rounded; frons sloping in front. Fontanelle minute, circular, with a small brown fontanelle tube; situated medially at about anterior third on head-dorsum. Eyes and ocelli absent. Antennae with 12-19 segments; segments 2-4 variable in size. Labrum subtriangular in shape; tip long, needle-like, apilose; blunt, not needle-like in some species from Australia and South America (See 'Note' below). Postclypeus flat, pilose, of same colour as head-capsule; faintly demarcated from frons. Mandibles long, sabre-shaped, slightly incurved at tips; left mandible with a large, blunt basal projection and 3 to 4 crenulations in basal half on inner margin; right mandible with one or two minute crenulations at the basal wider portion. Postmentum long, club-shaped. Pronotum flat, subreniform, narrower than head-capsule and wider than long; sides converging posteriorly; anterior margin weakly to

appreciably notched medially; posterior margin straight to faintly invaginated medially. Legs thin and long; apical tibial spurs 3:2:2; tarsi 4-jointed. Abdomen oblong; cerci 2-jointed and styli single-jointed.

*Note on soldier of Heterotermes* : The genus *Heterotermes* was described by Froggatt from Australia on the basis of *H. platycephalus*. Since then a number of species have been described from various zoogeographical regions except the Palaearctic. The genus comprises species having the labrum needle-like and acuminate in the case of soldier in some and bluntly-tipped-one in others. Recently Tsai and Hwang (1983) have transferred some of the *Reticulitermes* species, described from China, to the genus *Heterotermes* for having labrum with acute apex, and have suggested a possible transference of some of the Australian species to *Reticulitermes*. The soldier of South American species also has the labrum bluntly-tipped. We have not examined the Australian and South American species in the light of Tsai and Hwang's (1983) remarks and, therefore, have no comments to make at this juncture. We have treated the genus *Heterotermes* as referred to in literature.

*Worker* : Head pale yellowish; body paler; head and body fairly densely hairy. Head-capsule subsquarish; posterior margin rounded, sides substraight. Fontanelle indistinct. Eyes and ocelli absent. Antennae with 12-16 segments. Postclypeus weakly swollen, hairy; anteclypeus flat, hyaline. Mandibles as in imago. Pronotum, legs and abdomen as in soldier.

## 2. *Distribution and Composition of Heterotermes*

*Distribution* (Fig. 217) : The genus *Heterotermes* is cosmotropical in distribution and is reported from all the zoogeographical regions except the Palaearctic. It is found both in humid tropics and arid areas.

*Composition* : Twenty-six species of the genus *Heterotermes* are known from the world (Chhotani 1985) of which the following 5 occur in the Indian Region :

1. *Heterotermes balwanti* Mathur & Chhotani. India.
2. *H. ceylonicus* (Holmgren). Sri Lanka.

- 3. *H. gertrudae* Roonwal. India.
- 4. *H. indicola* (Wasmann). India, Pakistan, Bangladesh.
- 5. *H. malabaricus* (Snyder). India.

3. Keys to Indian Region Species of *Heterotermes*

IMAGOES

Imago caste of 4 out of the 5 species of the genus, reported from the Indian region, are known and are keyed as follows :

- 1(4) Ocelli absent
- 2(3) Larger species : Head-width with eyes 0.89-0.95, pronotum-width 0.84-0.89 mm. Eyes broadly oval. Antennae with 19 segments ..... *gertrudae*
- 3(2) Smaller species : Head-width with eyes 0.80-0.88, pronotum-width 0.60-0.70 mm. Eyes elongately oval. Antennae with 13-16 segments ..... *malabaricus*
- 4(1) Ocelli present
- 5(6) Antenna with 15-segments ..... *ceylonicus*
- 6(5) Antenna with 16-17 segments ..... *indicola*

SOLDIERS

- 1(2) Smaller species : Head-length to base of mandibles 1.00-1.10, width 0.70-0.75 mm. Mandibles slender and weakly incurved apically; longer in comparison to head-length without mandibles, index Left mandibular-length/Head-length to base of mandibles 0.68-0.78 ..... *balwanti*
- 2(1) Larger species : Head-length to base of mandibles 1.25-1.78, head-width 0.77-1.05 mm. Mandibles thick and more strongly incurved apically; shorter in comparison to head-length without mandibles, index Left mandibular-length/Head-length to base of mandibles 0.50-0.65.
- 3(4) Generally larger : Head-length 1.50-1.78 (mean 1.65), head-width 0.97-1.05 (mean 1.02), pronotum width 0.83-1.00 (mean 0.87) mm. Head strongly diverging in front ..... *gertrudae*
- 4(3) Generally smaller : Head-length 1.3-1.77, head-width 0.83-1.00; pronotum width 0.67-0.83 mm. Head either not or very weakly diverging in front
- 5(6) Antenna with generally more than 14 segments. Pronotum appreciably notched both at anterior and posterior margins. Generally larger : Head-length to base of mandibles 1.33-1.77 (mean 1.545), head-width 0.83-1.00 (mean 0.888), pronotum width 0.67-0.83 (mean 0.699) mm ..... *indicola*

- 6(5) Antenna with 12-14 segments. Pronotum weakly notched at anterior margin and substraight or faintly emarginate at posterior margin. Generally smaller : Head-length to base of mandibles 1.23-1.65, head-width 0.77-1.00, pronotum-width 0.53-0.80 mm
- 7(8) Postmentum wider at waist, index Width at waist/Max. width 0.43-0.50 (mean 0.48). Head less so hairy and somewhat larger (length to base of mandibles 1.30-1.69, head-width 0.85-1.00 mm). Antennae with 13-14 segments ..... *ceylonicus*
- 8(7) Postmentum narrower at waist, index Width at waist/ Max. width 0.38-0.43 (mean 0.40). Head more hairy and somewhat smaller (length to base of mandibles 1.23-1.54, head-width 0.77-0.95 mm). Antennae with 12-14 segments ..... *malabaricus*

### 70. *Heterotermes balwanti* Mathur and Chhotani (Figs. 248, 249)

*Heterotermes balwanti* Mathur and Chhotani :

1969. Mathur and Chhotani, *J. Timber Dev. Assoc. India*, 15(4): 4-8, 10. S, W. Holotype: S, in FRI, Dehra Dun. Type-locality : Balukhand For. Range, near Puri, Orissa, India, Type examined.
1979. Roonwal, *Termite Life and Termite Contr. Trop. South Asia* : 117.
1979. Thakur and Sen-Sarma, *Indian For. Rec. (N.S.) Ent.*, 13(2): 1, 4, 5-7, 18, 19-20.
1983. Chhotani, *Orient. Insects*, 17: 118.
1983. Bose and Das, *Rec. zool. Surv. India*, 80: 198, 199, 202, 210.
1987. Bose and Das, In *Fauna of Orissa, State Fauna Ser.*, No. 1: 104, 108.

IMAGO : Not known.

**SOLDIER (Fig. 248) :** Head-capsule creamish white to yellowish brown; body whitish; mandibles dark brown. Head moderately and body fairly densely hairy. Total body-length c 3.3-4.0 mm. Head-capsule subrectangular, about one-and-a-half times as long as wide (length to base of mandibles (1.00-1.10, width 0.70-0.75 mm); sides parallel; posterior margin round; anteriorly swollen and with a median groove; frons sloping sharply in front. Fontanelle minute; leading into a small, brownish tube; situated at base of median groove. Eyes and ocelli absent. Antennae with 12-14 (mostly 14) segments; segment 3 variable, generally subequal to or sometimes a little longer than 4. Labrum triangular (length with tip 0.30-0.38, width 0.20-0.25 mm); with a long, acuminate, hyaline tip; a pair of

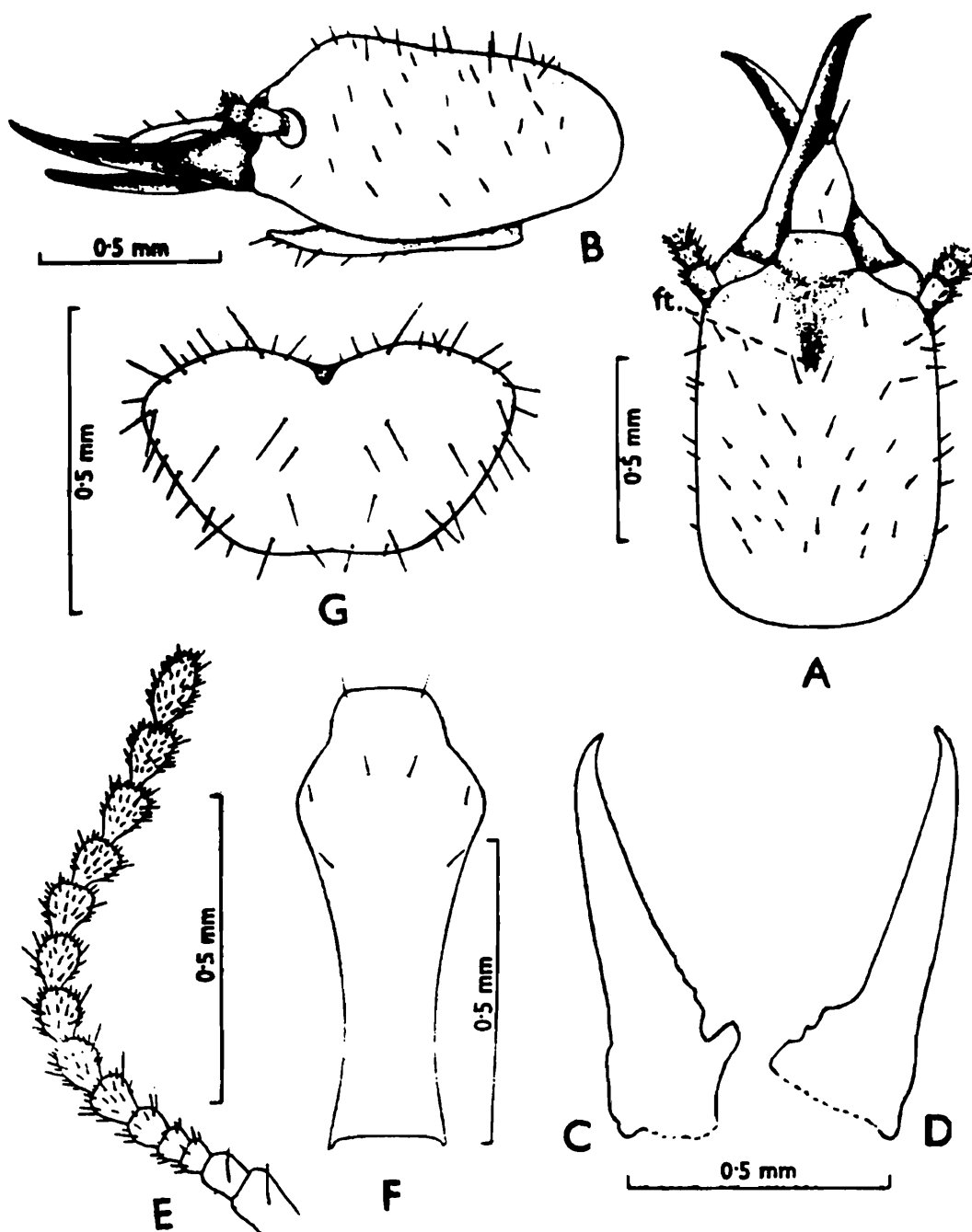

Fig. 248. *Heterotermes balwanti*. Soldier. (A) Head, dorsal view. (B) Same, side view. (C) and (D) Left and right mandibles. (E) Antenna. (F) Postmentum. (G) Pronotum. ft., fontanelle. (After Mathur and Chhotani 1969).

long hairs at base of tip and a few short-ones on body, present. Anteclypeus hyaline, strip-like, apilose; postclypeus separated from frons by a faint line. Mandibles thin, sabre-shaped, length 0.73-0.78 mm; about  $\frac{3}{4}$  of head-capsule, index Mandible-length/Head-length 0.68-0.78, otherwise as in genus. Postmentum long, club-shaped (length 0.70-0.88, max. width 0.30-

0.35, width at waist 0.15-0.18 mm); waist lying a little behind middle; a few short hairs present on broader portion. Pronotum flat, subreniform; length 0.30-0.35, width 0.50-0.55 mm; anterior margin weakly to fairly deeply and broadly notched medially; posterior margin with a faint median incurving. Legs thin and slender, apical tibial spurs 3:2:2; tarsi 4-jointed. Abdomen oblong, fairly densely hairy; cerci 2 jointed; styli single-jointed.

**WORKER** (Fig. 249) : Head-capsule pale yellowish; body paler. Head and body moderately densely hairy. Total body-length c 2.80-3.50 mm. Head-capsule subsquarish, a little broader than length to base of mandibles (length to base of mandibles 0.73-0.85, max. width 0.75-0.85 mm). Eyes and ocelli absent. Fontanelle indistinct. Antennae with 13-14 segments. Postclypeus weakly swollen, length less than half of width. Mandibles as in

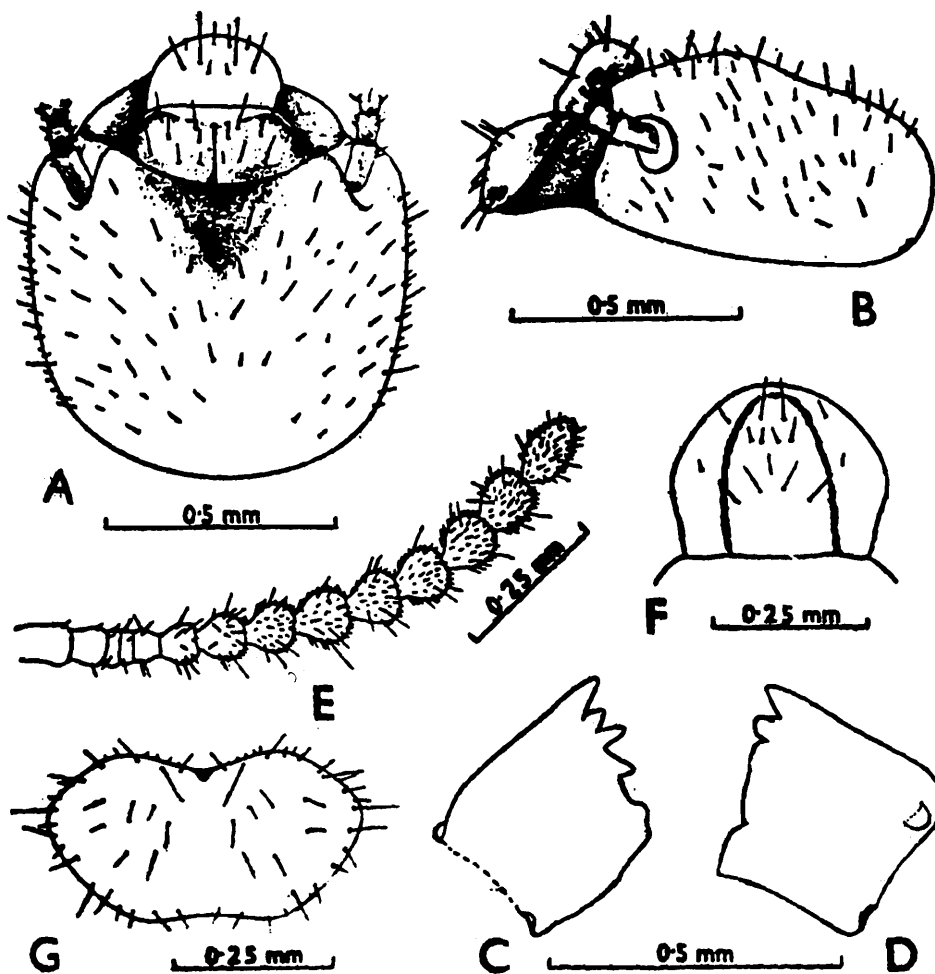

Fig. 249. *Heterotermes balwanti*. Worker. (A) Head, dorsal view. (B) Same, side view. (C) and (D) Left and right mandibles. (E) Antenna. (F) Labrum. (G) Pronotum. (After Mathur and Chhotani 1969).

genus. Pronotum flat (length 0.25-0.33, width 0.40-0.55 mm); a little upturned anteriorly; anterior margin deeply notched medially. Legs and abdomen as in soldier.

*Distribution* : INDIA : Orissa : Balukhand Forest Range near Puri (type-locality), Barkuda Island, Puri and Rambha. Karnataka : Dharwar. Goa : Valpoi Forest Range, North Goa Forest Division.

71. *Heterotermes ceylonicus* (Holmgren)  
(Figs. 250, 251)

1. *Leucotermes ceylonicus* Holmgren :

1911. Holmgren, In Escherich's *Termitenleben auf Ceylon* : 190-191. Im, S,W. Syntypes: In Holmgren Coll., National. Museum, Stockholm. Type-locality : Peradeniya, Sri Lanka.

1913. Holmgren, *K. Sv. Vet. Akad. Handl.*, 50(2): 65-66.

2. *Heterotermes ceylonicus* (Holmgren) :

1933. Snyder, *Proc. U.S. natnl. Mus.*, 82(Art. 16): 5.

1941. Beeson, *Forest Insects* : 544.

1949. Snyder, *Smiths. misc. Colls.*, 112: 67.

1953. Rattan Lal and Menon, *Cat. Indian Insects, Part 27, Isoptera* : 30.

1958. Ahmad, *Biologia*, Lahore, 4(1): 68-70.

1961. Harris, *Termites : Recognition & Control* : 152, 156. (2nd Ed. 1971).

1967. Roonwal and Chhotani, *J. Bombay nat. Hist. Soc.*, 63(2): 355, 357.

1970. Roonwal, In *Biology of Termites* (Eds. Krishna and Weesner) Vol. 2: 333.

1979. Roonwal, *Termite Life & Termite Contr. Trop. South Asia* : 51, 62, 79, 117.

1979. Thakur and Sen-Sarma, *Indian For. Rec. (N.S.) Ent.*, 13(2): 4, 7-10.

1980. Chhotani, *Tech. Monogr. Zool. Surv. India*, No. 4: 27, 29.

1983. Chhotani, *Orient. Insects*, 17: 118.

See Snyder 1949, Rattan Lal and Menon 1953 and Thakur and Sen-Sarma 1979 also for synonymy.

IMAGO (Fig. 250) : Head pale yellowish brown; wings pale yellow; body paler than head. Head and body densely hairy interspersed with long bristles; wings weakly hairy and thickly covered with micrasters. Total body-length with wings c 9.5-10.01, without wings 4.5-6.0 mm. Head-

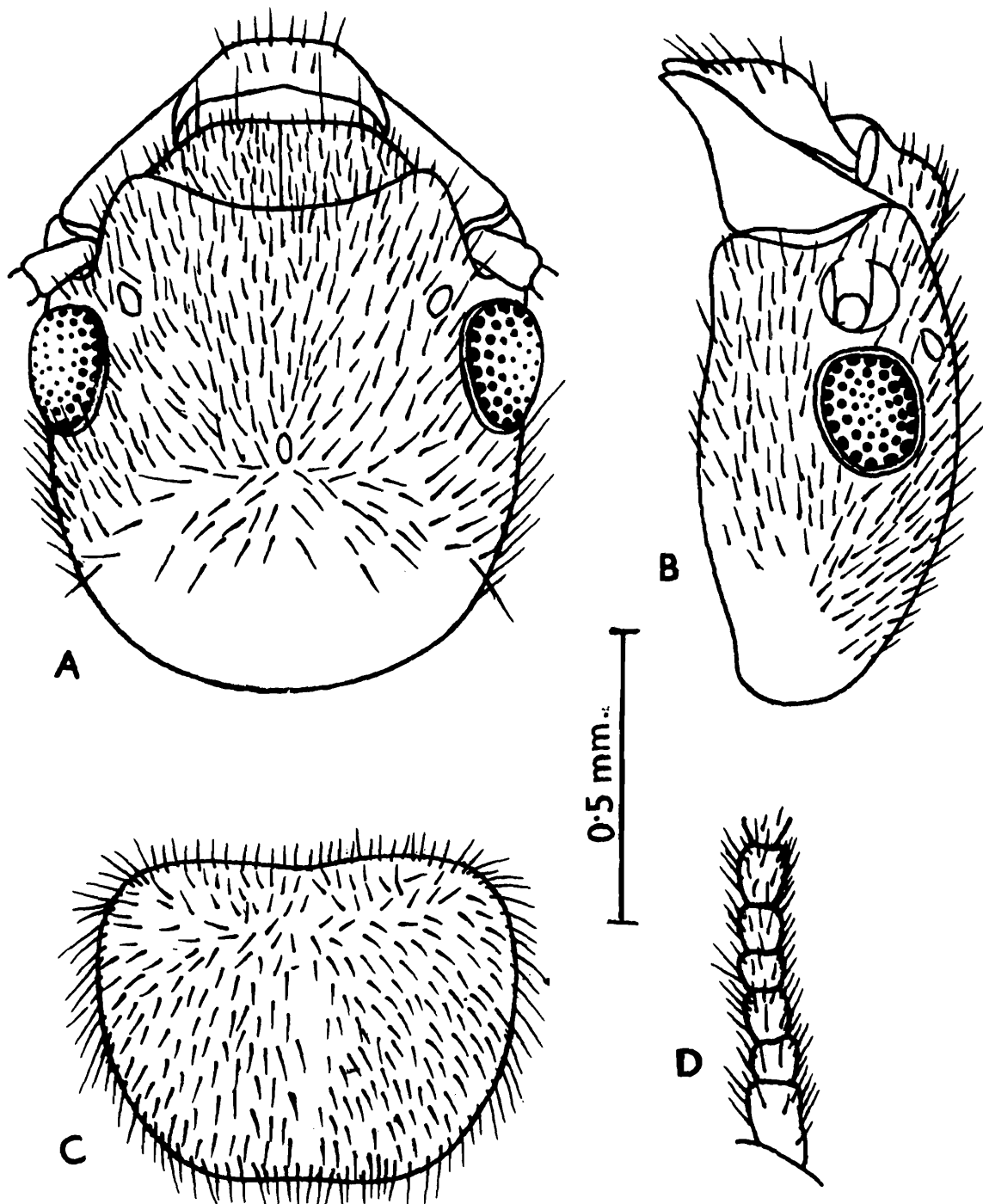

Fig. 250. *Heterotermes ceylonicus*. Imago. (A) Head, dorsal view. (B) Head, side view. (C) Pronotum, dorsal view. (D) Basal part of antenna. (Redrawn from Thakur and Sen-Sarma 1979).

capsule subsquarish, parallel sided; almost as wide (0.80-0.85 mm) as its length to base of mandibles (0.80-0.90 mm). Fontanelle minute, situated on mid-dorsum of head. Eyes small, oval (0.20-0.23 × 0.17-0.20 mm), weakly projecting; situated at a distance of less than their short diameter from lower

margin of head. Ocelli very small, oval (0.05-0.08 mm long); from the eyes at their long diameter. Antennae with 15 segments; segment 3 longer than 2; 4 as long as 2. Postclypeus weakly swollen; length less than half its width. Mandibles typically *Heterotermes*-type. Pronotum trapezoidal; with a faint, T-shaped marking on disc and with rounded side margins and corners; longer than half of width and narrower than head; length 0.45-0.53, width 0.68-0.70 mm; anterior margin faintly incurved medially and slightly raised; posterior margin imperceptibly notched. Wings slender and delicate, whitish. Forewing 7.5-8.0 mm long; venation as in genus, cubitus giving off 10-12 branches to posterior margin. Hindwing 7.0 mm long; venation as in genus, cubitus with 9-11 branches to posterior margin. Abdomen elongate, thickly hairy; Cerci 2-jointed, 0.88 mm long. Styli (in male) single jointed, 0.05 mm long.

**SOLDIER MAJOR (Fig. 251) :** Head-capsule yellow to yellowish brown; body paler; mandibles dark brown. Head sparsely and body fairly densely hairy. Total body-length c 4.5-6.0 mm. Head-capsule subrectangular, cylindrical; much longer than broad, length to base of mandibles (1.38-1.69 mm); a little more than one-and-a-half times that of width (0.85-1.0 mm); sides substraight; posteriorly rounded. Fontanelle minute, circular, opening at end of a small fontanelle tube at about anterior third on head-dorsum. Eyes and ocelli absent. Antennae with 14-segments; segment 2 longer than 3, the latter shortest. Anteclypeus hyaline, apilose; postclypeus pilose, of same colour as frons and separated from it by a weak line. Labrum subtriangular, with a sharp acuminate tip, reaching up to 2/3 of mandibles. Mandibles long (0.80-0.85 mm), sabre-shaped; length about half to little less than 2/3 of head without mandibles; left with a large basal projection and 4 crenulations on basal half; right with 1 or 2 faint crenulations at broad basal part. Postmentum long, club-shaped; narrowest behind middle; length 0.80-1.25, max. width 0.35-0.45, width at waist 0.15-0.20 mm. Pronotum flat, subreniform; narrower than head and a little longer than half its width, length 0.38-0.50, width 0.63-0.75 mm; anterior margin weakly incurved medially, posterior margin straight or faintly incurved. Legs thin and long; apical tibial spurs 3:2:2; tarsi 4-jointed. Abdomen oblong; cerci short, 2-jointed; styli single-jointed, finger-like.

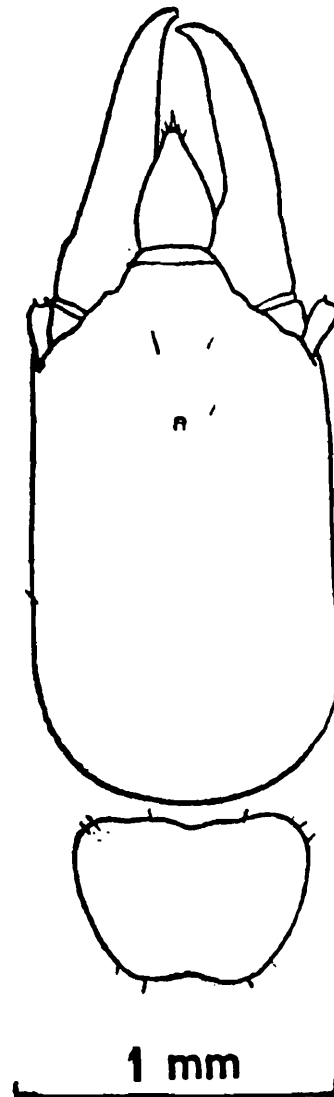

Fig. 251. *Heterotermes ceylonicus*. Soldier. Head and pronotum, dorsal view. (After Chhotani 1980).

**SOLDIER MINOR** : Smaller than soldier major. Total body-length 3.0-4.0, head-length to base of mandibles 1.23, head-width 0.80 and pronotum width 0.57 mm. Antenna with 13-14 segments. Otherwise as in soldier major.

**WORKER** : Head-capsule pale yellow to yellowish; body paler. Head and body fairly densely hairy. Total body-length c 3.00-5.00 mm. Head-capsule subsquarish, about as wide as length to base of mandibles; length to base of mandibles 0.80, width 0.80-0.85 mm. fontanelle indistinct. Eyes and

ocelli absent. Antennae with 13-14 segments; segment 2 as long as 3 and 4 combined together. Postclypeus weakly swollen, shorter than half of width. Mandibles as in imago. Pronotum as in soldier but with a deep, median notch at anterior margin. Legs and abdomen as in soldier.

*Distribution* : The species is widely distributed in Sri Lanka.

## 72. *Heterotermes gertrudae* Roonwal (Figs. 252-254)

### 1. *Heterotermes gertrudae* Roonwal :

1953. Roonwal, *Indian J. Ent.*, 15(2): 115-118. S, W. Holotype: S, in AMNH. Type-locality: Almora (Uttar Pradesh, India). Type examined.

1976. Roonwal and Verma, *Rec. zool. Surv. India*, 69: 241-247.

1976. Verma and Thakur, *Newsl. zool. Surv. India*, 2(4): 140.

1977. Roonwal and Rathore, *Zool. Anz.*, 198: 300.

1979. Roonwal, *Termite Life & Termite Contr. Trop. South Asia* : 7, 51, 79, 117.

1979. Roonwal, Verma and Thakur, *Proc. Indian natnl. Sci. Acad.*, (B) 45(4): 349, 350.

1983. Chhotani, *Orient. Insects*, 17: 118.

### 2. *Heterotermes indicola* (Wasmann). Part. Wrong determination :

1979. Thakur and Sen-Sarma, *Indian For. Rec. (N.S.) Ent.*, 13(2): 10-11. (Treat *gertrudae* as synonym of *indicola*.)

**IMAGO** (Figs. 252, 253) : Head-capsule yellowish brown; body yellowish brown dorsally and paler ventrally; antennae and legs paler than head. Both head and body fairly densely hairy. Total body length with wings 10.0-11.5 and without wings 5.5-5.8 mm. Head-capsule subcircular, almost as wide as length to base of mandibles; length 0.89-0.95, width with eyes 0.89-0.95 mm; sides weakly narrowing behind; posterior margin round. Fontanelle minute, situated on mid-dorsum of head. Eyes broadly oval, of medium size and very weakly projecting; max. diameter 0.23, min. diameter 0.18-0.20 mm. Ocelli absent. Antennae with 17 segments; segment 3 a little smaller than 2; 4 shortest. Postclypeus weakly swollen, shorter than half of width, pilose; anteclypeus apilose, hyaline, strip-like. Labrum broad, tongue-shaped with a few short hairs distally and on body. Mandibles typically *Heterotermes*-type. Pronotum flat, slightly narrower than head-

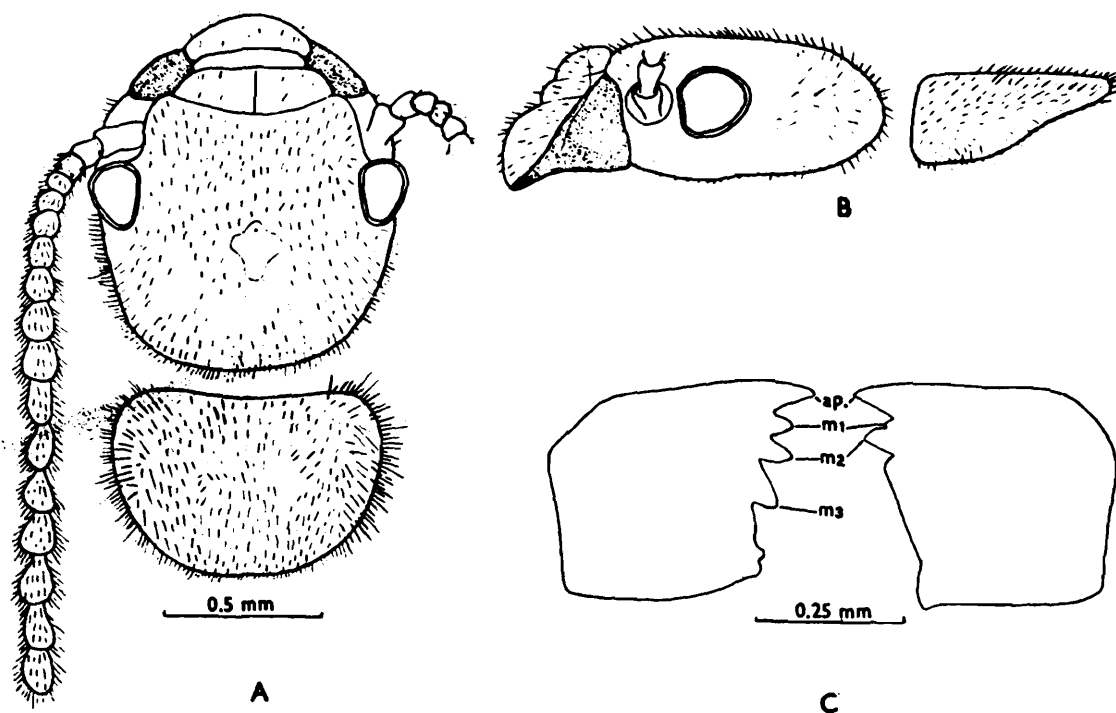

Fig. 252. *Heterotermes gertrudae*. Imago. (A) Head and pronotum, dorsal view. (B) Same, side view. (C) and (D) Left and right mandibles. ap., apical tooth; m<sub>1</sub>, m<sub>2</sub> and m<sub>3</sub>, first, second and third marginal teeth. (After Roonwal and Verma 1976.)

capsule; longer than half of width; length 0.47-0.53, width 0.84-0.89 mm; anterior margin weakly incurved, without median notch; sides rounded and a little narrowed behind; posterior margin round not notched medially. Legs rather short; apical tibial spurs 3:2:2; tarsi 4-jointed, arolium absent. Wings slender, colourless, translucent; with a few short hairs, anterior veins more so hairy. Microsculpturing consists of finger-shaped or tongue-shaped papillae in 3-4 rows on anterior part of costa ( $3-6 \times 2-3 \mu\text{m}$  and density  $8,200/\text{mm}^2$ ) and micrasters both asteroid and non-asteroid arranged in circles, spirals and oblongs ( $4-8 \times 2-6 \mu\text{m}$ , density  $4000/\text{mm}^2$ ). Forewing : 8.0-9.0 mm without scale. Venation as in genus; cubitus with 11 branches. Hindwing: 7.5-8.5 mm long without scale. Venation as in genus; media arising from radius outside scale, running across medially and bifurcating near distal end; cubitus with nearly 10 branches to posterior margin. Abdomen elongate, hairy; cerci short, 2 jointed; styli single-jointed.

**SOLDIER (Fig. 254) :** Head-capsule yellowish brown; body pale yellow; mandibles dark brown. Head sparsely and body fairly hairy, last 3 segments

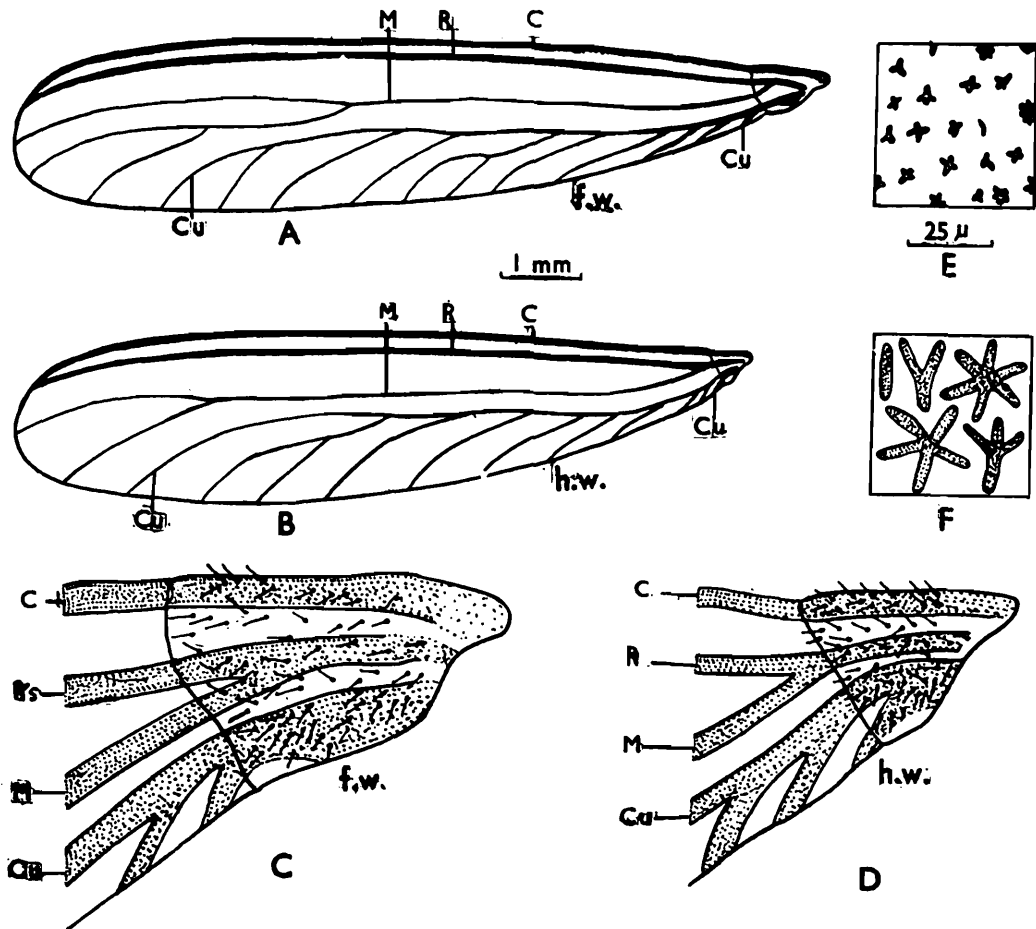

Fig. 253. *Heterotermes gertrudae*. Wings. (A) Left forewing. (B) Left hindwing. (C) Forewing scale, enlarged to show origin of veins. (D) Same, hindwing. (E) Some micrasters on forewing membrane. (F) Same, enlarged and re-arranged.

C., costa; Cu., cubitus, M., media; R., radius; Rs., radial sector; Sc., subcosta (After Roonwal and Verma 1976).

of abdomen moderately densely hairy. Total body-length c 4.9-6.0 mm. Head-capsule subrectangular; sides narrowing posteriorly; hind margin rounded; length without mandibles (1.50-1.78 mm) width (0.97-1.05 mm) about 2/3 of head-length. Fontanelle minute, circular, leading into a small tube behind; situated at distal third on head-dorsum. Anteclypeus hyaline, apilose, thin, strip-like; postclypeus pilose, not clearly demarcated from frons. Labrum subtriangular with a fine, sharply acuminate distal tip; with a pair of long bristles and few short hairs at base of distal tip and a few short

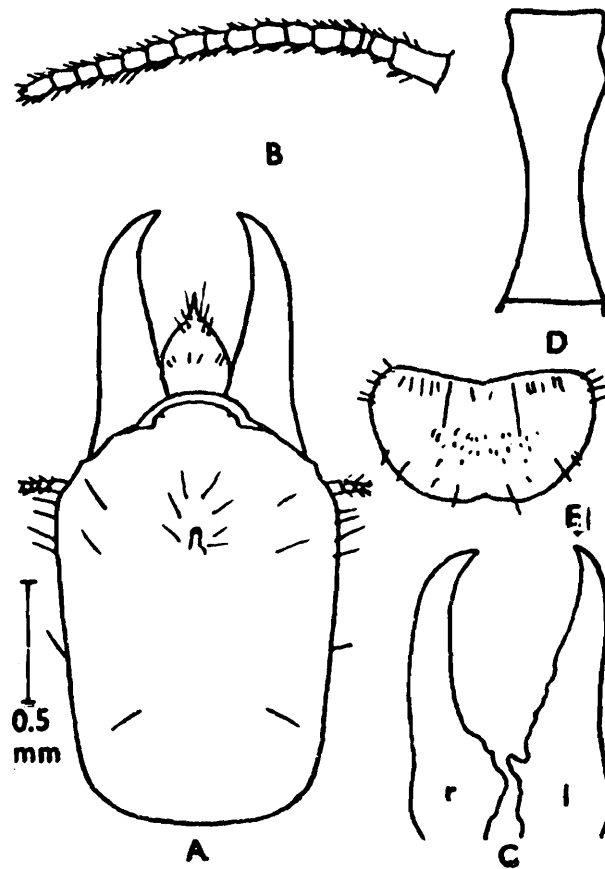

Fig. 254. *Heterotermes gertrudae*. Solider. (A) Head, dorsal view. (B) Antenna. (C) left and right mandibles. (D) Postmentum. (E) Pronotum. (After Roonwal 1953.).  
l., left; r., right.

hairs on body. Mandibles long, sabre-shaped, 0.90-1.05 mm long; incurved at distal tip; left with a basal blunt projection and a few crenulations in proximal half on inner margin; right with one or two minute crenulations on broad basal portion. Antennae with 12-17 (mostly 14-15) segments; segment 2 subequal to 3 + 4; 3 shortest; 4 onward gradually increasing in length; last ovate. Postmentum long, club-shaped; narrowed at about middle; length 1.13-1.50 mm, max. width 0.30-0.38 and width at waist 0.13-0.19 mm. Pronotum flat, subreniform; anterior margin slightly incurved and with a weak, median notch; posterior margin also with a weak notch in middle. Legs thin and slender; apical tibial spurs 3:2:2; tarsi 4-jointed. Abdomen oblong, fairly densely hairy posteriorly.

**WORKER** : Head pale yellow, body paler. Head and body fairly densely hairy. Total body length c 4.5-6.00 mm. Head-capsule subsquarish; width 0.86-1.14 mm. Fontanelle indistinct. Eyes and ocelli absent. Antennae with 13-16 (mostly 15) segments. Postclypeus weakly swollen. Mandibles and labrum as in imago. Pronotum, legs and abdomen as in soldier.

*Distribution* : INDIA : North West Himalayas: Almora and Rishikesh (Uttar Pradesh) and Melha (Himachal Pradesh).

### 73. *Heterotermes indicola* (Wasmann)

(Figs. 255, 256)

#### 1. *Leucotermes indicola* Wasmann :

1902. Wasmann, *Zool. Jb. (Syst.)*, 17(1): 118-119. S,W. Lectotype : S (designated O.B. Chhotani), in Nat. Hist. Mus., Maastricht, Type-locality: Bombay, India.

1904. Desneux, *Genera Insect.*, Fasc. 25: 33.

#### 2. *Heterotermes indicola* (Wasmann) :

1933. Snyder, *Proc. U.S. natnl. Mus.*, 82(Art. 16): 5.

1941. Beeson, *Ecol. & Contr. Forest Insects India*: 525, 544.

1949. Snyder, *Smiths. misc. Colls.*, 112: 68.

1955. Chaudhry, *Pakistan J. For.*, 5: 41.

1955. Ahmad, *Biologia*, Lahore, 1(2): 212-213, 215-218.

1956. Roonwal, *Z. ang. Ent.*, 38: 103-104.

1958. Ahmad, *Biologia*, Lahore, 4(1): 68-70.

1960. Weidner, *Abdh. Ver. naturw. Ver. Hamburg*, 4: 57.

1961. Harris, *Termites: Their Recognition & Contr.* : 152, 156. (2nd Ed. 1971).

1967. Roonwal and Chhotani, *J. Bombay nat. Hist. Soc.*, 63(2): 355, 357.

1970. Roonwal, In *Biology of Termites* (Eds. Krishna and Weesner) Vol. 2: 333-334.

1975. Sen-Sarma et al. *Wood Destroying Termites of India* (Final Tech. Rep. PL. 480 Proj.): 11, 24, 46-47, 64.

1977. Roonwal and Verma, *Rec. zool. Surv. India*, 72: 427, 434-435, 460, 464.

1977. Roonwal and Rathore, *Zool. Anz.*, 198: 299, 300-301.

1979. Chhotani and Bose, *Zoologiana*, No. 2: 20.

1979. Roonwal, *Termite Life & Termite Contr. Trop. South Asia*: 16, 38, 43, 45, 51, 52, 53, 56, 58, 61, 62, 117, 134, 143-146.

1979. Chhotani and Das, *Proc. Symp. Zool. Surv. India*, No. 1: 47-52.
1979. Roonwal, Verma and Thakur, *Proc. Indian natnl. Sci. Acad.*, (B) 45(4): 349, 350.
1979. Thakur and Sen-Sarma, *Indian For. Rec. (N.S.) Ent.*, 13(2): 4, 10-15.
1980. Chhotani, *Tech. Monogr. Zool. Surv. India*, No. 4: 26-27.
1980. Sen-Sarma and Thakur, *Indian For. Rec. (N.S.) Ent.*, 14(1): 9-11.
1983. Chhotani, *Orient, Insects*, 17: 118.
1985. Roonwal, *Proc. Indian natnl. Sci. Acad.*, (B) 51(1): 7-10.
1985. Chhotani, *Z. ang. Ent.*, 100: 93.

See Snyder 1949 and Thakur and Sen-Sarma 1979 also for synonymy.

**IMAGO (Fig. 255)** : Head-capsule and thorax straw yellow to light brown; antennae, labrum and abdominal tergites paler. Head sparsely and body moderately pilose. Total length with wings c 10.00-11.70 mm, without wings c 5.40-6.50 mm. Head-capsule subsquarish, almost as long as broad, length to base of mandibles 0.80-1.00, width with eyes 0.85-1.00 mm; sides subparallel, converging to a rounded posterior margin. Fontanelle, small, circular, situated at middle of head. Eyes medium sized, long diameter 0.20-0.25, short diameter 0.15-0.20 mm, slightly bulging; separated from lower margin of head by about its short diameter. Ocelli very small, dot-like, separated from eyes by about half the short diameter of eye. Antennae with 16 to 18 segments; segments 3 and 4 subequal, shortest. Postclypeus weakly swollen; length less than half of width. Labrum and mandibles as in genus. Pronotum flat, trapezoidal; width about one-and-a-half times length; width 0.70-0.80, length 0.43-0.65 mm; narrower than head-width with eyes; anterior margin almost straight; posterior margin substraight with a slight emargination in middle. Wings weakly hairy; venation as in genus; sculpturing consists of spiked papillae in 3-4 rows on anterior part of front vein ( $3.5-5.5 \times 2-3 \mu\text{m}$ , 5400/mm<sup>2</sup>) and leafy, V-shaped, non-asteroid and asteroid micrasters arranged in circles, ovoids and spirals ( $6-9 \times 2-8 \mu\text{m}$ , 5330/mm<sup>2</sup>). Forewing : 7-8 mm and hindwing 6.5-7.6 mm long. Legs long, slender, apical tibial spurs 3:2:2, tarsi 4-segmented. Abdomen oblong, pilose.

**SOLDIER (Fig. 256)** : Head-capsule pale yellow to yellowish brown; mandibles light to dark brown, basally paler. Head with a few large and several small hairs; abdomen fairly pilose. Total length c 3.5-6.10 mm.

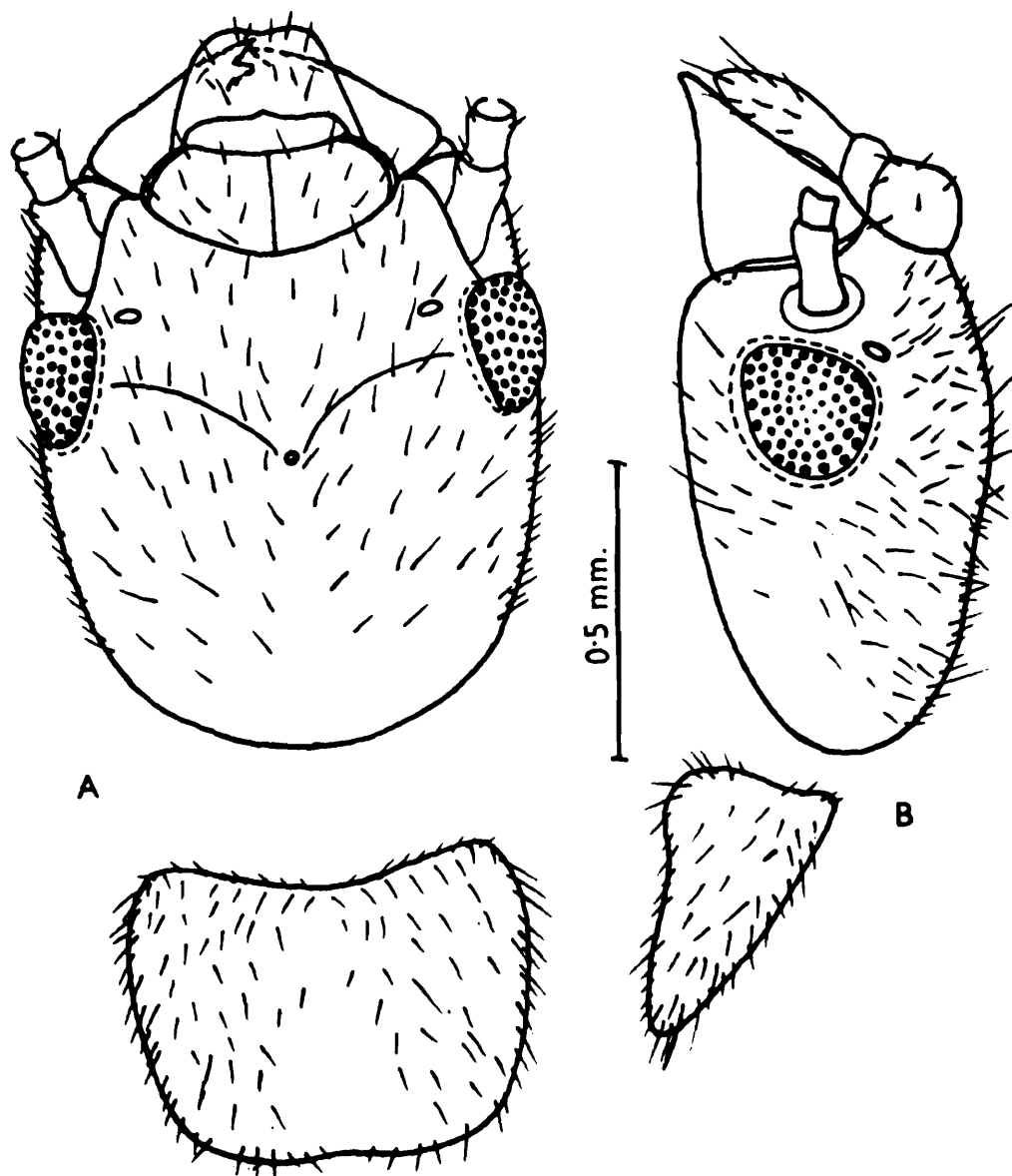

Fig. 255. *Heterotermes indicola*. Imago. (A) Head and pronotum, dorsal view. (B) Same, side view.

Head-capsule rectangular, much longer than broad, length to base of mandibles 1.25-1.77, width 0.83-1.00 mm; sides subparallel or faintly converging to a broadly rounded posterior margin; frons sloping gently in front. Fontanelle small, with a brownish tube; fontanelle gland area pale yellowish. Antennae with 14-16 (generally 15) segments; segment 3 variable either shorter or longer than 2 and either subequal to or longer than 4. Labrum triangular, with a hyaline, spine-like tip (0.08-0.10 mm in length); length much more than width, extending upto two-thirds of

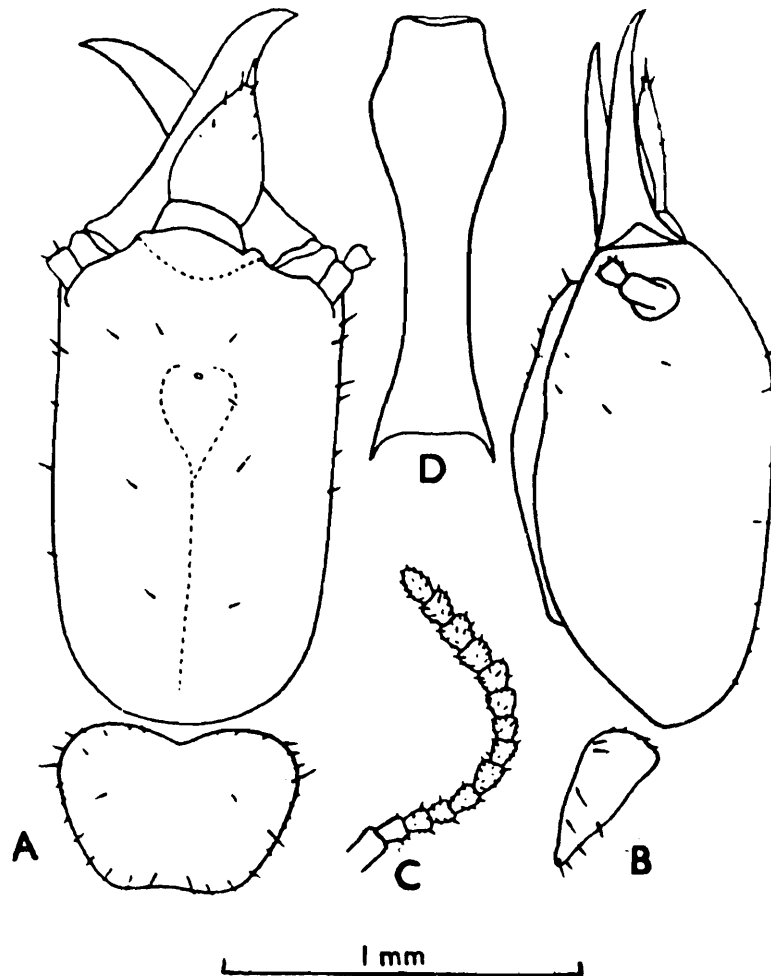

Fig. 256. *Heterotermes indicola*. Soldier (Lectotype). (A) Head and pronotum, dorsal view. (B) Same, side view. (C) Antenna. (D) Postmentum.

mandible-length. Mandibles fairly long (0.73-0.93 mm), sabre-shaped, outer margin fairly straight with incurved apices, inner margin also fairly straight upto apices; left mandible with 3-4 crenulations in basal part of inner margin. Postmentum club-shaped, fairly long; widest in anterior part or at club from whence sides incurving to anterior and posterior parts; length of postmentum 0.83-1.23, max. width 0.35-0.37 and minimum width at waist 0.17-0.20 mm. Pronotum flat, subtrapezoidal; anterior margin substraight, medially weakly to distinctly notched; posterior margin also weakly to deeply notched; broader than long, width 0.60-0.83, length 0.35-0.50 mm. Legs long, pilose, apical tibial spurs 3:2:2; tarsi 4-segmented. Abdomen oblong, moderately pilose; cerci 2-jointed; styli single-jointed.

**WORKER** : Head-capsule pale yellow to brownish yellow, rest of body paler. Head-capsule sparsely and body fairly pilose. Total length c 3.00-

5.00 mm. Head-capsule subsquarish, slightly wider than long, widest at base of antennae (1.00-1.07 mm). Fontanelle indistinct. Eyes and ocelli absent. Antennae with 14-15 segments; segment 2 subequal to or shorter than 3 + 4. Postclypeus weakly swollen, length half of width. Labrum and mandibles as in genus. Pronotum flat (0.30-0.35 mm long and 0.60-0.65 mm wide), anterior margin substraight with a distinct median notch, posterior margin substraight to weakly emarginate. Legs and abdomen as in soldier.

*Distribution* : It is a very common wood-destroying termite in the Indian subcontinent and is found all over above 20°N. latitude and extends in distribution upto Afghanistan.

*Biology* : It causes extensive damage to woodworks in houses in northern India and is also reported to destroy paper, records, clothes and stored products of cellulosic nature. The wood is hollowed out leaving only the outer shell. The infestation in houses can be made out from the galleries running on walls and ceiling to reach wooden structures. Swarming occurs during rainy season.

#### 74. *Heterotermes malabaricus* Snyder (Fig. 257)

*Heterotermes malabaricus* Snyder :

1933. Snyder, *Proc. U.S. natnl. Mus.*, 82(Art. 16) : 4-6. Lectotype : S, in FRI, Dehra Dun. Type-locality: Mangalore, Karnataka, India. Syntype imagoes examined.
1949. Snyder, *Smiths. misc. Colls.*, 112: 68.
1958. Ahmad, *Biologia*, Lahore, 4(1): 69-70.
1961. Harris, *Termites: Recognition & Control*: 152, 156. (2nd Ed. 1971).
1970. Roonwal, In *Biology of Termites* (Eds. Krishna and Weesner) Vol. 2: 334.
1974. Sen-Sarma, In *Ecology and Biogeography in India* (Ed. M.S. Mani) : 452-453.
1975. Sen-Sarma et al. *Wood Destroying Termites of India* (Final Tech. Rep. PL 480 Proj.): 11, 24-25, 47, 64.
1978. Roonwal *Z. ang. Ent.*, 85: 17.
1979. Thakur and Sen-Sarma, *Indian For. Rec. (N.S.) Ent.*, 13(2): 4, 5-18. (Lectotype designated.)
1980. Chhotani, *Tech. Monogr. Zool. Surv. India*, No. 4: 27, 28-29.
1984. Bose, *Occ. Pap. Rec. zool. Surv. India*, No. 49: 79-81.

See Snyder 1949 and Thakur and Sen-Sarma 1979 also for synonymy.

**IMAGO (Fig. 257A) :** Head-capsule and pronotum yellowish brown, rest of thorax and abdomen paler; postclypeus, antennae and labrum yellowish; mandibles yellowish brown with dark toothed margins. Head with dense, light yellow, long and short hairs; pronotum and abdomen densely hairy; abdomen with a row of bristles at base of each tergite. Total length without wings 4.75-6.00. Head-capsule subsquarish, almost as long as broad, widest across eyes, posterior margin rounded; length 0.70-0.90, width 0.80-0.88, length to tip of labrum 1.15-1.25 mm. Eyes blackish, oval weakly bulging; maximum diameter 0.20-0.23, minimum diameter 0.18-0.20 mm; separated from lower margin of head by a distance less than their short diameter (0.15-0.18 mm). Ocelli absent. Fontanelle prominent, raised, a hyaline spot, diameter 0.05 mm; situated near middle of head in line with back of eyes. Antennae with 13-16 (usually 14) segments; segment 3 shorter than 2, longer than 4. Postclypeus swollen, about three times wider than long. Labrum broadly tongue-shaped. Mandibles as in genus. Pronotum flat, trapezoid; broader than long (length 0.45-0.55, width 0.60-0.70 mm); densely pilose with long bristles and short hairs; anterior margin weakly emarginate, indented in middle; posterior margin substraight to weakly emarginate. Legs long, tibial spurs 3:2:2, tarsi 4-jointed. Wings smoky, margins hairy; membrane with a few hairs; venation as in genus. Length of forewing 7.55, length of forewing scale 0.65 mm. Abdomen oblong, densely hairy; cerci 2-jointed.

**SOLDIER (Fig. 257B) :** Head-capsule and labrum light yellow brown to brown; mandibles dark brown, basally pale; antennae, pronotum and abdomen paler than head. Head and body sparsely pilose. Total length 3.20-5.00 mm. Head-capsule subrectangular, much longer than broad; length to base of mandibles 1.23-1.54, width 0.77-0.95 mm; sides subparallel; posterior margin rounded. Fontanelle small with a narrow tube, situated near anterior third of head. Antennae with 12-14 segments; segment 3 shortest. Labrum subtriangular (length 0.35-0.43, width 0.25-0.30 mm); sides converging anteriorly to a hyaline, pointed, needle-like tip. Mandibles sabre-shaped, long (0.70-0.93 mm); length more than half of head-length to base of mandibles; outer margins substraight; apices weakly incurved. Left mandible with 3-4 crenulations in basal half of inner margin.

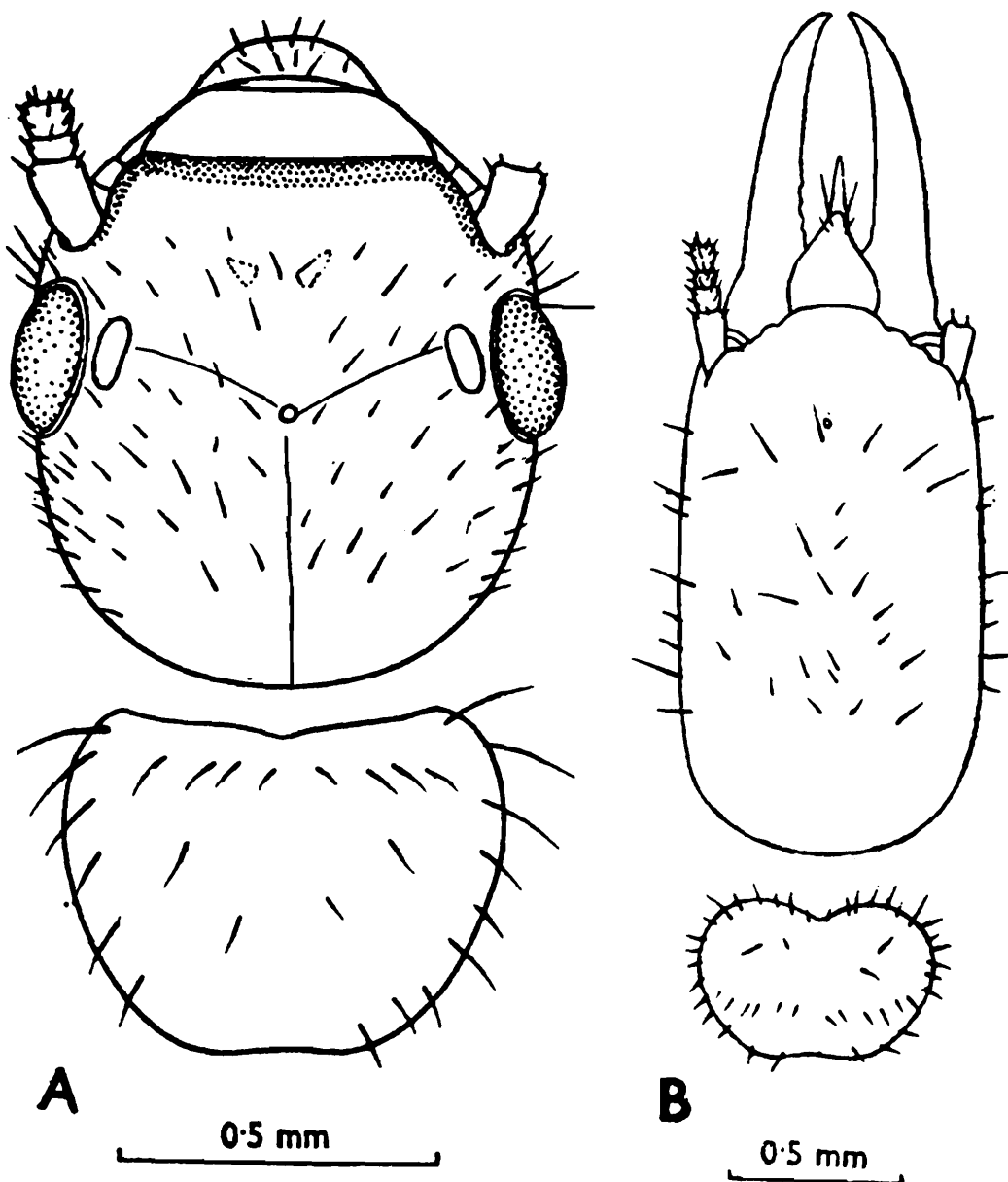

Fig. 257. *Heterotermes malabaricus*. Imago and soldier. (A) Head and pronotum of imago, in dorsal view. (B) Head and pronotum of soldier, in dorsal view (After Bose 1984.)

Postmentum club-shaped, length 0.82-1.25, maximum width (at club) 0.32-0.43, minimum width (at waist) 0.15-0.20 mm, waist lying in posterior one-third. Pronotum flat, trapezoid; much broader than long, width 0.53-0.80, length 0.33-0.50 mm; anterior margin distinctly emarginate, posterior

margin substraight or with a very weak median emargination. Apical tibial spurs 3:2:2, tarsi 4-jointed. Abdomen oblong, hairy; cerci 2-segmented.

**WORKER** : Head and body pale to deep yellow, rest of body paler. Head and body rather densely hairy. Total length 3.00-5.00 mm. Head-capsule subsquarish, a little broader than long; max. width 0.95 mm; sides subparallel; posterior margin rounded. Fontanelle indistinct. Antennae with 12-13 segments, segment 2 subequal to or longer than 3. Labrum dome-shaped, broader than long. Postclypeus weakly swollen, much broader than long. Mandibles as in genus. Pronotum flat, narrower than head; length 0.30-0.40, width 0.50-0.60 mm; anterior margin with a distinct median notch; posterior margin with a weak emargination. Legs and abdomen as in soldier.

*Distribution* : *H. malabaricus* is fairly wide spread in the Indian subcontinent below 20° N. For details vide Sen-Sarma et al. 1975.

*Biology* : It is reported from wood of a large number of species of trees and plants but not as pest of structural timber in houses (Sen-Sarma et al. 1975).

## Genus 16. *Reticulitermes* Holmgren

### 1. Subgenus *Reticulitermes* (of *Leucotermes*) Holmgren :

1913. Holmgren, *K. Sv. Vet. Akad. Handl.*, 50(2): 15 (misspelled as *Reticulotermes*), 60-61.

### 2. Genus *Reticulitermes* Holmgren :

1920. Banks and Snyder, *U.S. natnl. Mus. Bull.*, No. 108: 42-43.

1923. Snyder, *J. Washington Acad. Sci.*, 13(6): 107.

1931. Light, *Lignan Sci. J.*, 7: 589-590.

1949. Snyder, *Smiths. misc. Colls.*, 112: 71.

1950. Ahmad, *Bull. Amer. Mus. nat. Hist.*, 95(Art. 2): 53, 54.

1953. Rattan Lal and Menon, *Cat. Indian Insects, Pt. 27, Isoptera* : 29, 31.

1955. Emerson, *Fieldiana : Zool.*, 37: 470, 471, 472, 483, 490, 509.

1962. Roonwal and Chhotani, *Proc. natnl. Inst. Sci. India*, (B) 28(4): 294, 295, 301-305.

1968. Hsia and Fan, *Acta ent. Sinica*, 14(4): 360-382.

1970. Krishna, In *Biology of Termites* (Eds. Krishna and Weesner) Vol. 2: 137, 138.

1970. Roonwal, In *Biology of Termites* (Eds. Krishna and Weesner) Vol. 2: 334-335.
1970. Weidner, *Handb. d. Zool.*, 4(2): 21.
1971. Emerson, *Bull. Am. Mus. nat. Hist.*, 146(Art. 3): 248, 251, 257, 276-278.
1973. Chhotani and Bose, *Zool. Anz.*, 190(3/4): 233, 234.
1975. Emerson, and Krishna, *Am. Mus. Novit.*, No. 2570: 13, 14, 15, 16, 17, 18, 22.
1977. Chhotani, *Proc. 8th int. Cong. Int. Un. Study Social Insects* (Wageningen, Sept. 1977): 117.
1977. Roonwal and Chhotani, *Ent. Basil.*, 2: 42, 43.
1978. Clement, *Annals. Soc. ent. Fr.*, (N.S.), 14(2): 131-139.
1981. Roonwal, *Proc. Indian natnl. Sci. Acad.*, (B) 47(4): 471.
1983. Chhotani, *Orient. Insects*, 17: 111, 112, 114, 115.
1983. Chhotani and Das, *Rec. zool. Surv. India*, 80: 315-316.
1983. Maiti, *Occ. Pap. Rec. zool. Surv. India*, No. 42: 16, 22.
1983. Roonwal, *Proc. Indian natnl. Sci. Acad.*, (B) 49(5): 363.
1985. Chhotani, *Z. ang. Ent.*, 100: 91, 92, 93.
1986. Grasse, *Termitologia* Vol. 3: 521-522.
3. Genus *Leucotermes* (in part) Holmgren :
1911. Holmgren, *K. Sv. Vet. Akad. Handl.*, 46(6): 69.

Type of genus : *Termes flavipes* Kollar

### 1. Characters of Genus *Reticulitermes*

**Imago** : Generally darker species. Head-capsule oval, epicranial suture faint or absent. Fontanelle minute, slightly raised. Eyes oval, medium sized, weakly bulging. Ocelli small, hyaline, subcircular; separated from eyes, not touching. Antennae with 16-18 segments; segment 3 or 4 shortest. Labrum broad tongue-shaped. Anteclypeus flat, hyaline, apilose. subtrapezoid. Postclypeus faintly swollen, pilose. Mandibles subsquarish, each with an apical and 3 marginal teeth. Left mandible with the apical and 1st and 2nd marginals subequal, pointed and equidistant from each other, 3rd marginal smaller, with longer anterior margin and directed backwards. Right mandible with apical and 2nd marginal subequal; 1st marginal small, subsidiary tooth lying at base of 2nd marginal; 3rd marginal small with a long posterior margin (longer than molar plate). Pronotum flat, narrower

than head. Wings slender, microsculpturing consists of 2-4 rows of papillae on front vein and numerous, minute, rounded, glossy pimpules all over the membrane. Forewing scale longer than that of hindwing and covering the latter partly; costa (costa + subcosta and subcosta + radius of some authors) and radius thick; media running medially in wing-membrane and weak; cubitus also weak, with 8-12 branches. Hindwing : Venation as in forewing except media arising from radius. Legs with 3:2:2 apical tibial spurs; tarsi 4-jointed; arolium absent. Abdomen elongate, cerci 2-jointed; styli in males single-jointed.

**Soldier** : Head-capsule rectangular, width about half to two-thirds of length; sides substraight; frontal area generally raised forming frontal protuberances, one on either side whence frons sloping in front at about an angle of 45° or little more. Fontanelle minute, situated on mid-dorsum behind frontal protuberances, at about three-fourth of head-length from posterior margin. Antennae with 14-18 segments; segment 3 generally shortest, ring-like. Eyes and ocelli absent. Clypeus subtrapezoidal; postclypeus pilose and darker than anteclypeus; the latter hyaline and apilose. Labrum subtriangular, tongue-shaped; tip transparent, either blunt or somewhat pointed, generally with a pair of long bristles. Mandibles thick, generally stout, sabre-shaped; left generally with 3 to 4 crenulations (only proximal crenulation prominent in *saraswati*) and a basal projection in basal half; right with smooth inner margin except for one or two, minute crenulations basally. Postmentum club-shaped, with long and narrow waist. Pronotum flat, subrectangular, widest anteriorly; narrower than head-capsule, both anterior and posterior margins weakly to deeply notched medially. Legs long and slender, apical tibial spurs 3:2:2; tarsi 4-jointed. Abdomen oblong; cerci 2-jointed; styli single jointed.

**Worker** : Dimorphic. **MAJOR** : Head-capsule subsquarish. Fontanelle, eyes and ocelli absent. Antennae with 16-18 segments; segments 3 and 4 variable. Anteclypeus hyaline, apilose and narrow; postclypeus slightly swollen, length about one-third of width. Labrum subsquarish, anteriorly rounded. Mandibles as in imago. Pronotum flat; anterior margin weakly to appreciably notched medially. Legs and abdomen as in soldier. **MINOR** : As in worker major except for smaller size.

*2. Distribution and Composition of Reticulitermes*

*Distribution* (Fig. 217) : Genus *Reticulitermes* is essentially Palaearctic in distribution, it, however, extends into colder parts of the Oriental Region also. It is reported from China, North East India (Arunachal Pradesh, Assam, Sikkim, West Bengal), Bhutan, Indochina, Korea, Taiwan, Japan, North Africa, southern Europe and U.S.A.

*Composition* : Nearly 60 species of the genus are known, of which the following 4 occur in the Indian Region.

1. *Reticulitermes assamensis* Gardner. India, Bhutan, China.
2. *R. chinensis* Snyder. India, China.
3. *R. saraswati* Roonwal and Chhotani. India.
4. *R. tirapi* Chhotani and Das. India.

*3. Keys to Indian Region Species of Reticulitermes*

IMAGOES

The imagoes of the two species, known so far, are separated as follows :

- |   |                   |
|---|-------------------|
| 1(2) Ocelli separated from eyes by long diameter of ocellus; pronotum yellow; tibiae basally one-fourth brownish rest yellowish ..... | <i>assamensis</i> |
| 2(1) Ocelli separated from eyes by less than short diameter of ocellus; pronotum dark brown; tibiae yellowish all through.....        | <i>chinensis</i>  |

SOLDIERS

- |   |                   |
|---|-------------------|
| 1(2) Smaller species: Head-length without mandibles 1.53, head-width 1.00 mm .....  | <i>saraswati</i>  |
| 2(1) Larger species: Head-length without mandibles 1.75-2.32, head width 1.05-1.25 mm   |                   |
| 3(4) Labrum with a sharply pointed tip; frontal protuberances absent or ill developed .....   | <i>chinensis</i>  |
| 4(3) Labrum with a blunt tip; frontal protuberances well developed  |                   |
| 5(6) Head narrower and flat; head-width 1.05-1.12 (mean 1.07 mm), head-height 0.90-0.95 (mean 0.93 mm). Pronotum narrower (width 0.80-0.87, mean 0.82 mm) ..... | <i>tirapi</i>     |
| 6(5) Head wider and swollen; head-width 1.08-1.30 (Mean 1.18 mm) head-height 0.87-1.10, (mean 1.01 mm). Pronotum wider (width 0.77-0.92, mean 0.84 mm) .....    | <i>assamensis</i> |

**75. *Reticulitermes assamensis* Gardner**  
(Figs. 258, 259)

1. *Reticulitermes assamensis* Gardner :

1944. Gardner, *Indian J. Ent.*, 6: 105-106, Lectotype : S, in FRI, Dehra Dun. Type-locality: Sadiya, Assam, India. Types examined.

1953. Rattan Lal and Menon, *Cat. Indian Insects, Part 27, Isoptera* : 27, 31.

1977. Roonwal and Chhotani, *Ent. Basil.*, 2: 46-48. (Im. described).

1977. Thakur, *J. Bombay nat. Hist. Soc.*, 74(1): 191-195. (Lectotype designated)

1981. Roonwal, *Proc. Indian natnl. Sci. Acad.*, (B) 47(4): 471.

1983. Chhotani, *Orient. Insects*, 17: 118.

1983. Chhotani and Das, *Rec. zool. Surv. India*, 80: 315, 316-317.

1983. Roonwal, *Proc. Indian natnl. Sci. Acad.*, (B) 49(5): 363.

1983. Maiti, *Occ. Pap. Rec. zool. Surv. India*, No. 42: 42, 47-48.

1986. Gao and Lam, *Mem. Hongkong nat. Hist. Soc.*, 17: 82.

2. *Reticulitermes chinensis* Snyder (Wrong determinations, Indian records are *assamensis*) :

1949. Snyder, *Smiths. misc. Colls.*, 112: 71.

1953. Roonwal and Pant, *Indian Forest Leaflet (Ent.)*, No. 12(9): 54.

1962. Roonwal and Chhotani, *Proc. natnl. Inst. Sci. India*, (B) 28(4): 301-302.

1962. Mathur and Thapa, *Indian For. Leaflet (Ent.)*, No. 167: 27.

**IMAGO (Fig. 258) :** Head dark mahogany, shining; postclypeus, antennae, wing scales, coxae, femora, abdominal tergites and sternites blackish brown; pronotum yellow; tibiae brownish in proximal fourth otherwise yellow; tarsi yellowish; wings transparent, colourless; covered with papillae and pimpules. Head and body fairly densely hairy. Total body-length without wings 6.4 mm. Head-capsule long, oval, narrowed posteriorly; length to base of mandibles (1.10-1.17 mm) equal to width with eyes (1.10 mm). Fontanelle minute, centrally located, slightly raised. Eyes small, oval, weakly projecting and narrowed antero-laterally; situated at about their long diameter (0.23-0.27 mm) from lower margin of head. Ocelli small, subcircular, separated from eyes by their long diameter (0.07-0.10 mm). Antennae 17-segmented; segment 1 longest, cylindrical; 2 about half of one; 3 short and broad; 4 shortest. Clypeus divided into ante-and

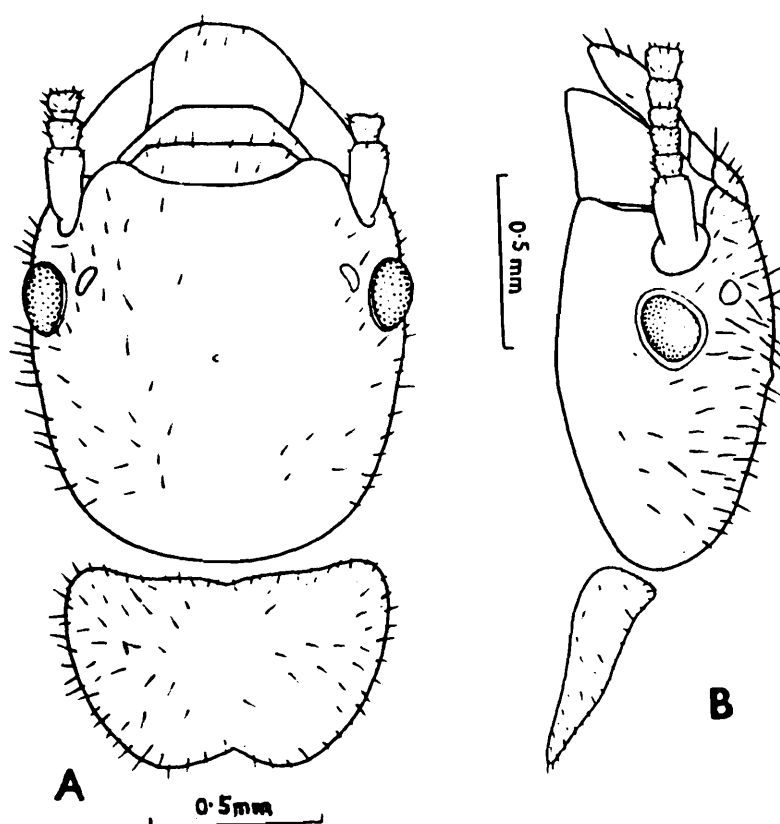

Fig. 258. *Reticulitermes assamensis*. Imago. (A) Head and pronotum, dorsal view. (B) Same, side view. (After Roonwal and Chhotani 1977).

postclypeus; anteclypeus hyaline, trapezoidal, apilose; postclypeus weakly swollen, pilose, length about one-third of width. Labrum broadly tongue-shaped; wider than long. Mandibles as in genus. Pronotum yellowish; a little narrower than head-width with eyes; anterior margin faintly wavy and prominently notched medially; posterior margin convex, deeply notched medially; length 0.60-0.70, width 0.90 mm. Wings transparent, colourless, without hairs; front veins brown, remaining ones colourless; 9-9.5 mm long; venation as in genus. Microsculpturing on wings consists of finger-like papillae ( $6-9 \times 3-6 \mu\text{m}$ ) on costa with 3-4 rows on anterior half and 2 rows on posterior half and round ( $1.5-2 \times 1.5-2 \mu\text{m}$ ), glossy and numerous ( $7000/\text{mm}^2$ ) pimples all over membrane. Legs short and stout; apical tibial spurs 3:2:2; tarsi 4-jointed; arolium absent. Abdomen elongate. Cerci 2-jointed, 0.15-0.17 mm long; styli (in male) single-jointed.

**SOLDIER (Fig. 259)** Head-capsule pale yellow to yellowish brown, a little darker in frontal region; antennae, labrum, body and legs paler than head-capsule; mandibles dark reddish brown, paler basally. Head fairly and body densely hairy. Total body-length 5.30-6.50 mm. Head-capsule subrectangular; width a little less than two-thirds of length to base of mandibles (length 1.75-2.32, width 1.08-1.30 mm; index Width/Length 0.56-0.62); sides subparallel, somewhat narrowed anteriorly; frontal protuberances prominently swollen; frons sloping at an angle of about 60°. Fontanelle minute, situated medially below frontal protuberances and at about distal third of head-capsule. Eye spots hyaline, either present or absent. Antennae with 15-16 segments; segment 1 cylindrical, longest; 2 about half of 1, cylindrical; 3 or 4 shortest, 3 sometimes only slightly shorter than 2 and in process of division. Clypeus divided into ante- and post-clypeus; postclypeus pilose, flat, subrectangular; anteclypeus hyaline,

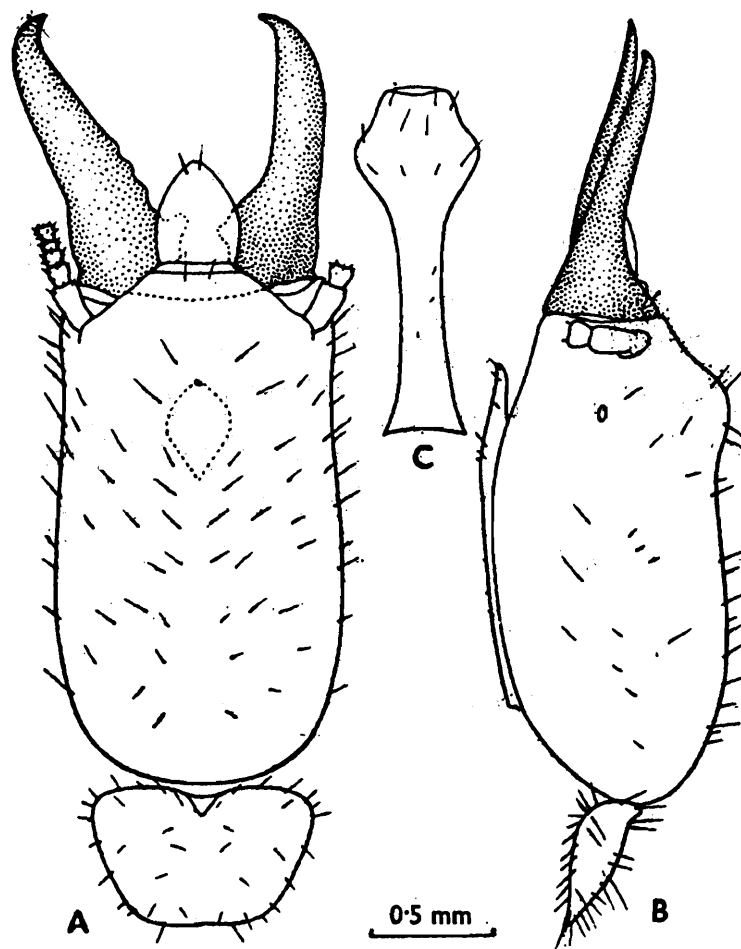

Fig. 259. *Reticulitermes assamensis*. Soldier. (A) Head and pronotum, dorsal view. (B) Same, side view. (C) Postmentum. (After Chhotani and Das 1983.)

apilose, trapezoidal. Labrum triangularly tongue-shaped with a blunt tip and a pair of long bristles at tip. Mandibles thick, stout, sabre-shaped; about half of head without mandibles (0.95-1.15 mm long); weakly incurved at outer margin in basal third; tip weakly incurved. Left mandible with 3-4 crenulations and a prominent basal projection on inner margin. Right mandible smooth on inner margin except for a rudimentary tooth-like projection near base. Postmentum club-shaped with a long, narrow stalk; width at waist one-fourth to one-third of maximum width (length 1.00-1.52, max. width 0.42-0.52, width at waist 0.12-0.17 mm). Pronotum flat; narrower than head-width; widest anteriorly, sides converging posteriorly; anterior margin with a prominent notch at middle; posterior margin with a weak, median incurving; length 0.42-0.62, width 0.77-0.97 mm. Mesonotum and metanotum narrower than pronotum, latter wider than former and both substraight at posterior margin. Legs fairly stout and hairy; apical tibial spurs 3:2:2; tarsi 4-jointed. Abdomen elongate, densely hairy; cerci 2-jointed, 0.10-0.12 mm long; styli single-jointed.

**WORKER** Head-capsule creamish to pale yellowish; antennae, labrum, legs and abdomen a little paler than head-capsule. Head and body fairly densely hairy. Total body-length 3.80-4.50 mm. Head-capsule subsquarish; sides weakly rounded; length to base of mandibles (1.0-1.02 mm) subequal to width (1.02-1.05 mm); posterior margin round. Fontanelle indistinct. Antennae 16-jointed. Postclypeus weakly swollen, about half of width in length. Mandibles as in imago. Pronotum, legs and abdomen as in soldier.

*Distribution* : INDIA (Assam, Arunachal Pradesh, Sikkim, West Bengal). Also Bhutan and China. For detailed distribution in Indian Region vide Chhotani and Das, 1983.

*Biology* : It is a subterranean termite and is reported from dead wood lying on jungle floor. It is not reported so far to damage woodwork in houses though it is quite common.

## 76. *Reticulitermes chinensis* Snyder (Figs. 260, 261)

### 1. *Reticulitermes chinensis* Snyder :

1923. Snyder, *J. Wash. Acad. Sci.*, 13: 107-109. Im, S. Holotype : Im, in USNM, Washington. Type-locality: Suifu, Szechuan Prov., China. Types examined.

1931. Light, *Lignan Sci. J.*, 7: 583-584, 589, 590.
1949. Snyder, *Smiths. misc. Colls.*, 112: 71 (Chinese records only).
1955. Tu, *Formosan Sci.*, 9(1): 2.
1962. Roonwal and Chhotani, *Proc. natnl. Inst. Sci. India*, (B) 28(4): 301-303. (Records from China only).
1962. Mathur and Thapa, *Indian For. Leaflet (Ent.)*, No. 167: 27. (Records from China only).
1977. Thakur, *J. Bombay nat. Hist. Soc.*, 74: 194.
1977. Lahiri, Ghosh and Biswas, *Bull. Meghalaya. Sci. Soc.*, 2: 35.
1986. Gao and Lam, *Mem. Hongkong nat. Hist. Soc.*, 17: 82.
2. *Reticulitermes chinensis chinensis* Snyder :
1968. Hsia and Fan, *Acta ent. Sinica*, 14(4): 2.
1983. Chhotani and Das, *Rec. zool. Surv. India*, 80: 315, 316, 318-323.
1983. Chhotani, *Orient. Insects*, 17: 118.

IMAGO (Fig. 260) The colouration, etc. of the various parts as mentioned by Snyder (1923) are given within parentheses. Head dark brown [dark castaneous brown (dark finished mahogany)]; postclypeus, coxae, meso-and metathorax yellowish brown; antennae pale brown (grey-brown); pronotum brown, slightly paler than head (about same color as head); femora yellowish brown (greyish brown); tibiae and tarsi yellowish; abdominal tergites pale brown [slightly lighter coloured (more grey) than head]; wings pale brownish. Head and body fairly densely hairy with light yellowish hairs. Total body-length without wings c 4.5-5.2, with wings 9.15-9.40 mm. Head oval, head-capsule subsquarish, slightly narrowed posteriorly, length to base of mandibles (0.97-1.0 mm) subequal to width with eyes (1.05 mm); epicranial suture faint. Fontanelle minute, slightly raised. Eyes small, broadly oval, max. diameter 0.22-0.23 mm; slightly bulging; anteriorly straighter; from lower margin of head separated by nearly 2/3rds of their long diameter. Ocelli small, max. diameter 0.08-0.10 mm, subcircular; separated from eyes by little less than short diameter and by their diameter from antennae. Antennae broken, maximum of ten segments (17-18 segments) present in one of the specimens; segment 1 long, cylindrical; 2 shorter than 1, cylindrical; 3 shortest, ring-like. Labrum broad, tongue-shaped, yellowish brown; wider than long, length 0.33-0.35, width 0.40 mm; with a few hairs anteriorly and medially on body. Postclypeus

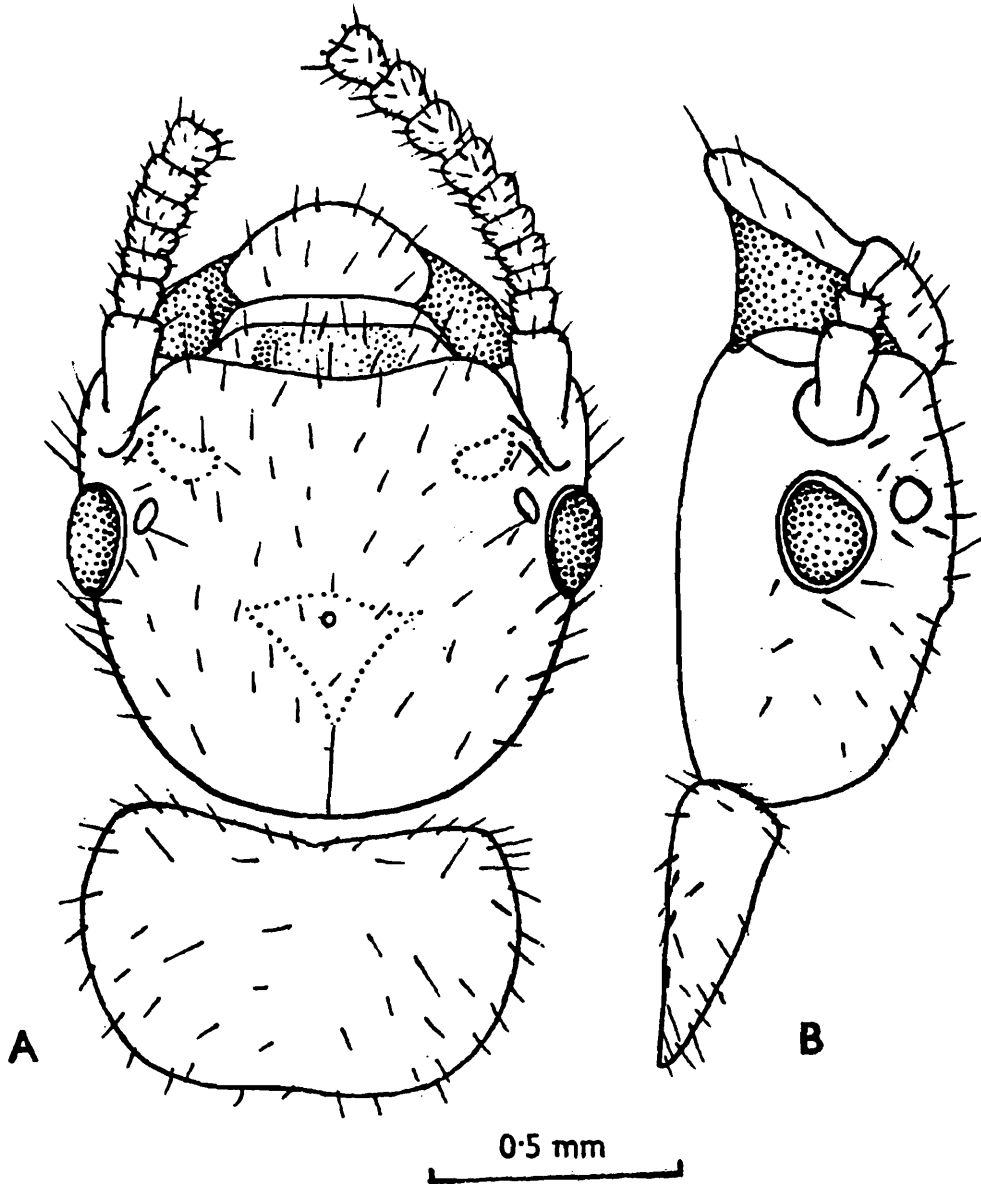

Fig. 260. *Reticulitermes chinensis*. Imago. (A) Head and pronotum, dorsal view. (B) Same side view. (After Chhotani and Das 1983.)

weakly swollen, length less than half of width, hairy. Anteclypeus flat, apilose, hyaline. Pronotum flat, subrectangular, narrower than head-width with eyes; anterior margin incurved and with a weak, median notch; posterior margin with a faint, median incurving; length 0.55-0.58, width 0.84-0.87 mm. Legs elongate, hairy, fairly stout; apical tibial spurs 3:2:2; tarsi 4-segmented. Wings broken in the specimens examined, a few

fragments available; membrane with minute pimpules. Abdomen elongate; cerci 2-segmented; styli single-jointed.

**SOLDIER (Fig. 261)** : Head-capsule straw yellow to yellowish brown; mandibles reddish brown; antennae, labrum, abdomen and legs yellowish white. Head-capsule sparsely and thorax and abdomen moderately, hairy. Total body-length c 5.90-7.10 mm. Head-capsule subrectangular, longer than wide, about 1.75 times as long as wide (length to base of mandibles 1.83-2.27, width 1.08-1.32 mm); sides subparallel; postero-lateral corners rounded; frontal protuberances weakly developed or absent. Fontanelle minute, circular; situated medially a little beyond 2/3rds of head-length from posterior margin. Antennae 16 to 18-segmented, pilose; in 18-

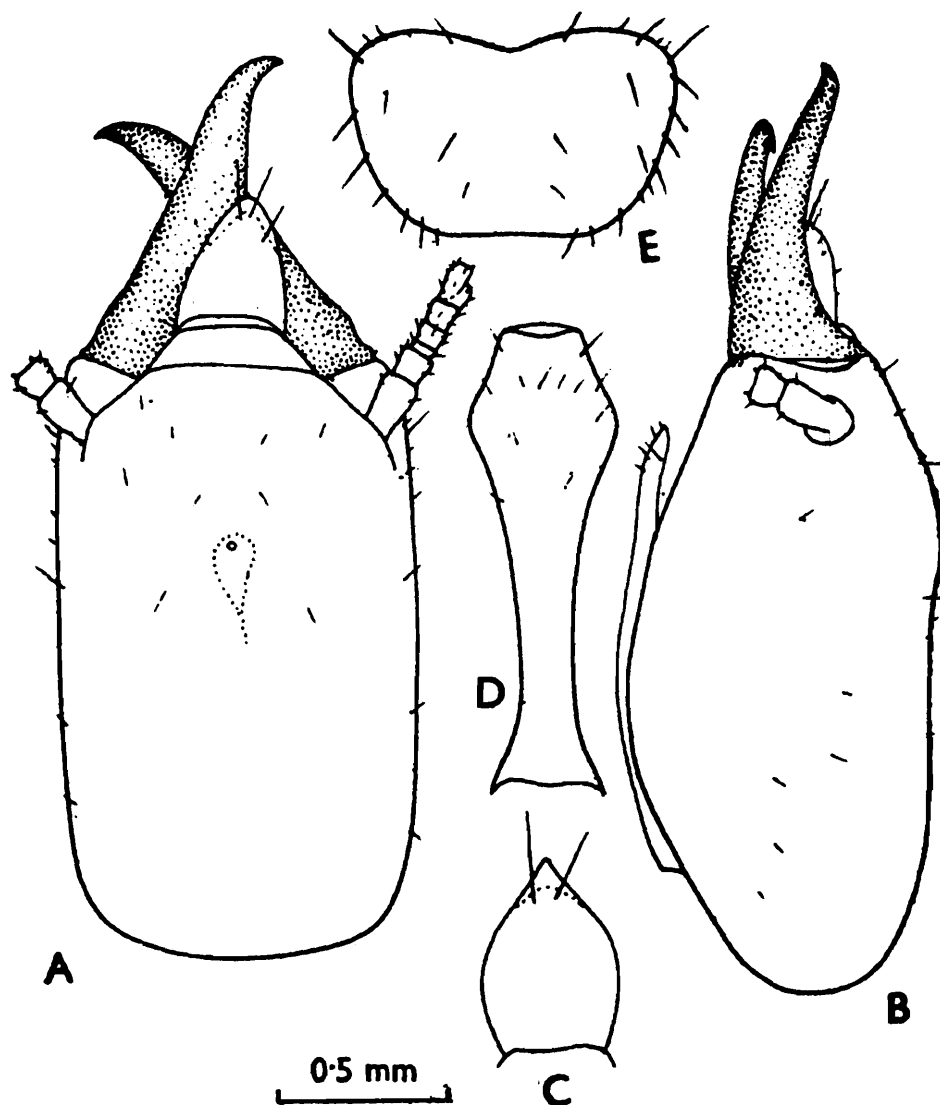

Fig. 261. *Reticulitermes chinensis*. Soldier. (A) Head, in dorsal view. (B) Same, in side view. (C) Labrum. (D) Postmentum. (E) Pronotum. Drawings (A) and (B) from paratype and (C) - (E) from a specimen from Arunachal Pradesh (After Chhotani and Das 1983.)

segmented antenna segment 4 smallest, segment 3 subequal to 5; in 16 and 17-segmented antennae segment 3 smallest, ring-like, 4 subequal to 2. Clypeus trapezoidal; anteclypeus narrow, hyaline, apilose; postclypeus wider and pilose. Labrum oval, longer than broad, usually broadest near the base; sides convex with hyaline margin and converging into thin and sharply pointed tip having 2 long bristles. In paratype soldier tip of labrum not sharply pointed, probably broken; according to Snyder (1923) it is pointed at apex. Mandibles short and stout (length 0.95-1.22 mm); with weakly incurved apices; left with 3-4 crenulations and a basal projection; right with smooth inner margin, basally with a minute tooth-like projection. Postmentum club-shaped, more than three times as wide at widest point as at waist; length 1.30-1.50, max. width 0.43-0.52, width at waist 0.12-0.15 mm; anterior margin substraight. Pronotum flat, narrower than head; widest anteriorly; anterior margin with a deep, median notch; posterior margin weakly notched medially; length 0.50-0.55, width 0.82-0.95 mm. Mesonotum narrower and metanotum slightly wider than, pronotum. Legs long, slender, pilose; tibial spurs 3:2:2; tarsi 4-segmented. Abdomen elongate, moderately hairy; cerci 2-segmented; styli single-segmented.

**WORKER** : Head-capsule pale yellow; antennae, legs and abdomen paler than head. Body less hairy than in *R. assamensis*. Total body-length c 3.50-4.00 mm. Head subsquarish (length to base of mandibles 1.05-1.07, max. width 1.17-1.22 mm); lateral and posterior margins rounded. Fontanelle indistinct. Antennae 15-segmented, segment 2 longer than 3, 4 shortest. Anteclypeus flat, apilose. Postclypeus slightly swollen, pilose, length less than one-third its width (length 0.12-0.15, width 0.45-0.50 mm). Labrum subsquarish, slightly wider than long, anterior margin convex. Mandibles typically *Reticulitermes*-type. Pronotum flat (length 0.42-0.50, width 0.77-0.85 mm); with a prominent, median notch at anterior margin. Mesonotum narrower and metanotum wider than, pronotum. Legs and abdomen as in soldier.

*Distribution* : Widely distributed species in China and recorded from a number of provinces. From the Indian Region, it is reported from Arunachal Pradesh (Kameng District) and Assam (Shantipur).

**77. *Reticulitermes saraswati* Roonwal and Chhotani**  
(Figs. 262, 263)

*Reticulitermes saraswati* Roonwal and Chhotani :

1962. Roonwal and Chhotani, *Proc. natnl. Inst. Sci. India*, (B) **28**(4): 289, 295, 303-306, 391, 393, 397. S, W. Holotype : S, in ZSI, Calcutta. Type-locality. Shillong, Meghalaya, India. Type examined.

1965. Roonwal and Chhotani, *J. Bombay nat. Hist. Soc.*, **62**(1): 21.

1977. Thakur, *J. Bombay nat. Hist. Soc.*, **74**: 194.

1977. Lahiri, Ghosh and Biswas, *Bull. Meghalaya Sci. Soc.*, **2**: 35.

1983. Chhotani and Das, *Rec. zool. Surv. India*, **80**: 316, 322, 323, 324, 327, 328, 329.

1983. Chhotani, *Orient. Insects*, **17**: 119.

IMAGO Not known.

**SOLDIER** (Fig. 262) Head-capsule straw yellow; labrum yellow, with a transparent tip; mandibles dark brown, paler basally; antennae, legs and body whitish. Head moderately and body fairly densely, pilose. Total body-length c 4.0 mm. Head-capsule subrectangular (length 1.53, max. width 1.00 mm), sides subparallel; frons swollen, with a pair of frontal protuberances at base and sloping at an angle of a little more than 45°. Fontanelle minute, circular, situated at base of swollen portion of frons. Antennae with 11 + segments; segment 3 shortest; 4 larger than 2. Clypeus not clearly differentiated into ante- and postclypeus. Labrum triangularly tongue-shaped, with a pair of long bristles at the transparent tip. Mandibles sabre-shaped, short and stout (length 0.86 mm); about half of head-length; left with only proximal crenulations distinct otherwise smooth, basal projection prominent; right mandible smooth, with a minute tooth near base. Postmentum club-shaped, broadest at anterior third whence sides narrowing behind into a long narrow waist; width at waist less than one-third of maximum width; length 1.08, max. width 0.40, width at waist 0.12 mm. Pronotum flat, rectangular, broadest anteriorly (length 0.40, max. width 0.67 mm); anterior margin with a prominent, obtuse, median notch; posterior margin with a weak, median notch. Mesonotum slightly narrower and metanotum slightly wider than pronotum; sides rounded and posterior margin straight in both. Legs thin and long. Abdomen elongately oval, cerci 2-jointed; styli single-jointed.

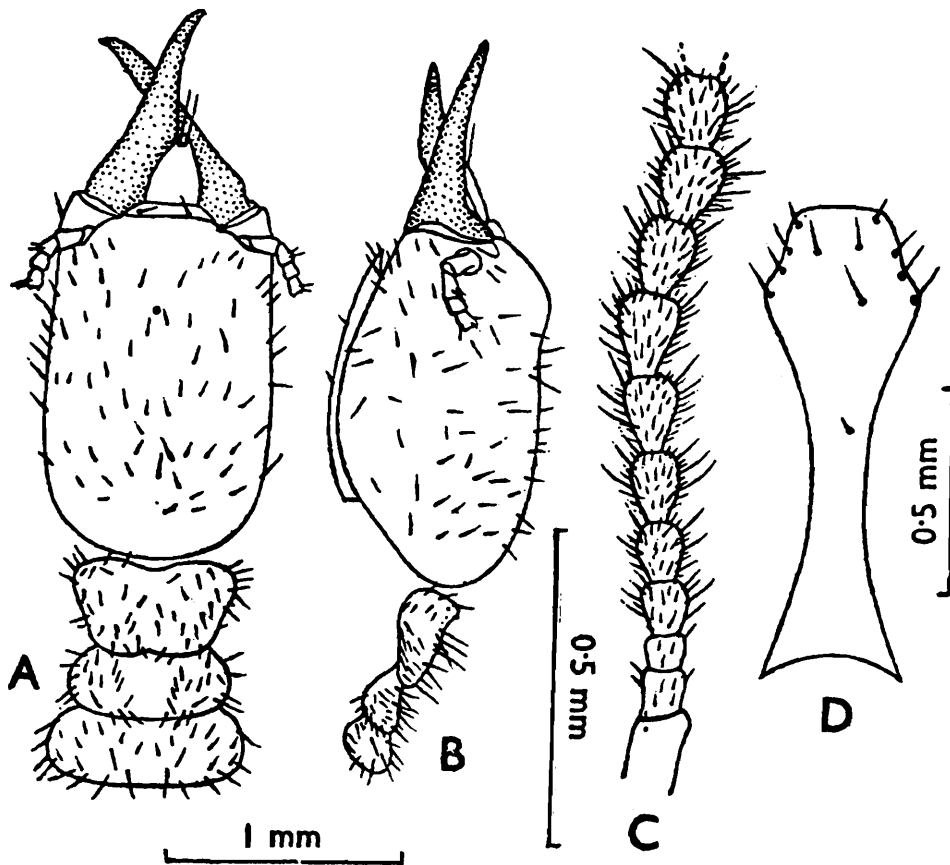

Fig. 262. *Reticulitermes saraswati*. Soldier. (A) Head and thorax, dorsal view. (B) Same, side view. (C) antenna. (D) Postmentum. (Redrawn from Roonwal and Chhotani 1962a.)

**WORKER MAJOR (Fig. 263) :** Head-capsule yellowish white; labrum pale yellow; antennae, legs and body paler than head. Head and body densely hairy. Total body-length 3.6-3.8 mm. Head-capsule subsquarish, sides weakly convex; length 1.03-1.07, width 1.03-1.07 mm. Fontanelle indistinct. Antennae with 14-15 segments, segments 3 and 4 ring-like. Postclypeus weakly swollen, pilose, length less than half of width; anteclypeus apilose, flat. Labrum subsquarish, anteriorly rounded. Mandibles as in genus. Pronotum flat, fairly densely pilose with brownish hairs; anterior margin weakly convex and deeply notched medially; posterior margin with a shallow, median notch; length 0.33-0.37, width 0.63-0.67 mm. Legs thin and long; apical tibial spurs 3:2:2; tarsi 4-jointed. Abdomen as in soldier.

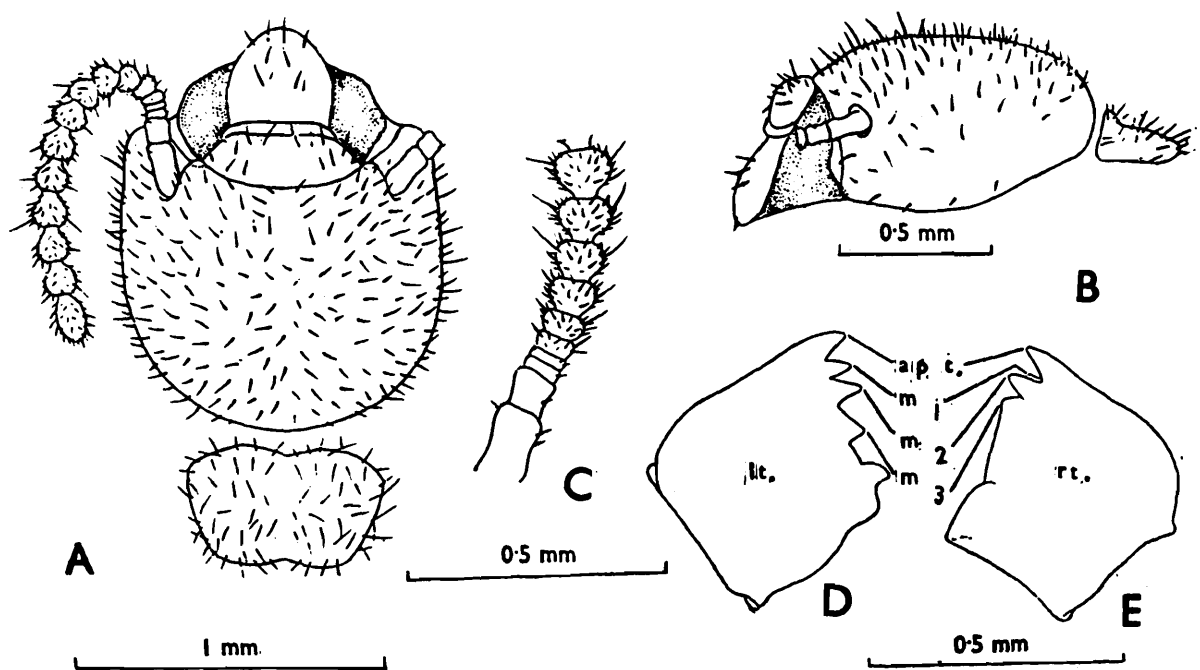

Fig. 263. *Reticulitermes saraswati*. Worker. (A) Head and pronotum, dorsal view. (B) Same. side view. (C) Antenna. (D) and (E) Left and right mandibles. (Redrawn from Roonwal and Chhotani 1962a).

**WORKER MINOR :** As in worker major except that it is smaller and has 13-14 antennal segments. Total body length 3.0, head-length to base of mandibles 0.80-0.86, width 0.83-0.90, pronotum width 0.47-0.50 mm.

**Distribution :** INDIA : Meghalaya : Shillong (type-locality).

### 78. *Reticulitermes tirapi* Chhotani and Das (Fig. 264)

*Reticulitermes tirapi* Chhotani and Das :

1983. Chhotani and Das, *Rec. zool. Surv. India*, 80: 316, 324-327, 328, 329. S, W.  
Holotype : S, in ZSI, Calcutta. Type-locality : Nampong (Tirap District, Arunachal Pradesh). Types examined.

1983. Chhotani, *Orient. Insects*, 17: 119.

**IMAGO :** Unknown.

**SOLDIER (Fig. 264) :** Head-capsule pale yellow, paler in frontal region; mandibles dark brown, slightly paler basally; antennae, labrum, thorax abdomen and legs yellowish white. Head-capsule sparsely and thorax and abdomen rather densely, hairy. Total body-length 6.30-6.80 mm. Head-capsule subrectangular, much longer than broad (length to base of

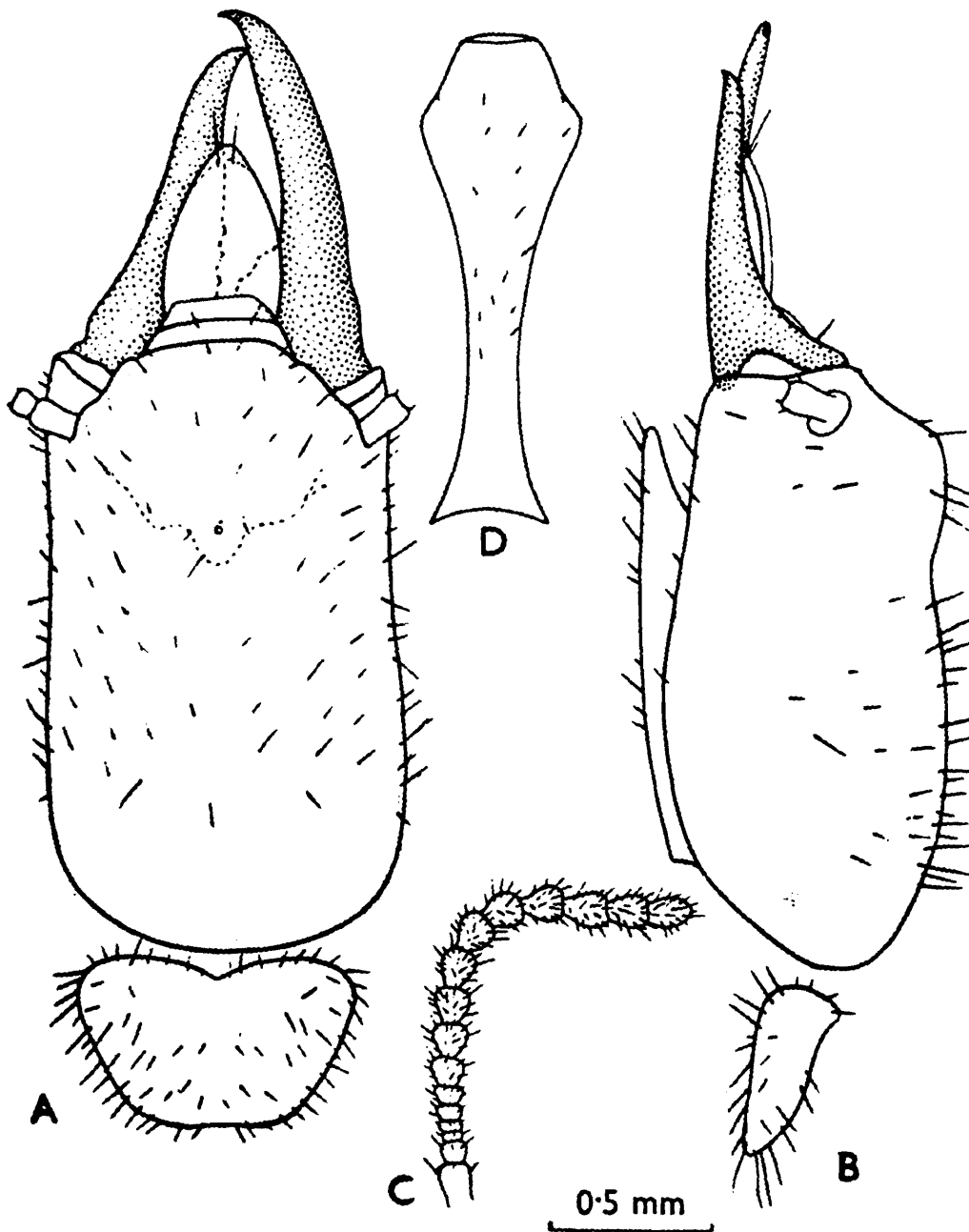

Fig. 264. *Reticulitermes tirapi*. Soldier. (A) Head and pronotum, dorsal view. (B) Same, side view. (C) Antenna. (D) Postmentum. (After Chhotani and Das 1983.)

mandibles 1.87-2.03, max. width 1.05-1.10 mm; index Width/Length 0.54-0.58); sides subparallel, slightly narrowed posteriorly; postero-lateral corners rounded, posterior margin weakly rounded; frontal region swollen into protuberances and steeply sloping in front. Fontanelle minute, placed at base of swollen part of frons. Antennae with 15-16 segments; in 15-segmented antenna, segment 3 longer than 4, latter as long as 5; in 16-segmented one, 3 shortest. Postclypeus subtrapezoidal, pale yellow, pilose; anteclypeus whitish, apilose, subrectangular, narrower than postclypeus. Labrum oval, narrower anteriorly; longer than broad, broadest near base; tip blunt and with two long hairs. Mandibles weakly incurved anteriorly, length (1.00-1.05 mm) half to slightly more than half of head-length; inner margin of left with 3 crenulations and a basal projection; right mandible with straight inner margin except for a minute tooth-like projection near base. Postmentum club-shaped; at widest point more than 3 times as wide as at waist; length 1.30-1.43, width 0.45-0.50, width at waist 0.12-0.15 mm. Pronotum flat, narrower than head, widest anteriorly; length 0.45-0.55, width 0.80-0.87 mm; anterior margin with a distinct median notch; posterior margin faintly incurved medially. Mesonotum narrower than pronotum, substraight at posterior margin. Metanotum as wide as pronotum, substraight posteriorly. Legs long, slender and pilose; tibial spurs 3:2:2; tarsi 4-segmented. Abdomen elongate, hairy; cerci 2-segmented; styli finger-like, single-jointed.

**WORKER** : Head-capsule pale yellow; antennae, labrum, abdomen, and legs yellowish white. Head moderately and thorax and abdomen densely, hairy. Total body-length c 3.70-4.20 mm. Head subsquarish (length to base of mandibles 0.87-1.00, max. width 1.00-1.10). Fontanelle indistinct. Antennae 16-segmented; segment 2 longer than 3; 4 shortest. Postclypeus slightly swollen, pilose; length about 1/3 its width (length 0.12; width 0.37 mm); medially divided into two halves; anteclypeus apilose, flat, whitish. Labrum broad, tongue-shaped, longer than wide. Mandibles as in genus. Pronotum flat (max. length 0.30-0.37; max. width 0.55-0.65 mm), broadest anteriorly; anterior margin with a weak, median notch and posterior-one faintly emarginate medially. Abdomen and legs as in soldier.

*Distribution* : INDIA Arunachal Pradesh: Nampong (Tirap District), known only from the type-locality.

## Subfamily (iv) TERMITOGETONINAE Holmgren

Subfamily Termitogetoninae Holmgren :

1910. Holmgren, *Zool. Anz.*, **35**: 285. (No description).
1910. Holmgren, *Trans. Linn. Soc. Lond. Zool.*, (2) **14**(8): 143. (No description).
1911. Holmgren, *K. Sv. Vet. Akad. Handl.*, **46**(6): 62, 63, 75.
1911. Holmgren, In Escherich's *Termitenleben auf Ceylon* : 206, 210.
1949. Snyder, *Smiths. misc. Colls.*, **112**: 84.
1950. Ahmad. *Bull. Am. Mus. nat. Hist.*, **95** (Art. 2): 56.
1955. Weidner, In *Die Termiten* (Ed. Schmidt): 10, 40, 56.
1961. Harris, *Termites: Recognition and Control*: 38, 47. (2nd Edition 1971).
1970. Weidner, *Handb. d. Zool.*, **4**(2): 11, 12.
1970. Krishna, In *Biology of Termites* (Eds. Krishna and Weesner) Vol. 2: 131, 137.
1970. Roonwal, In *Biology of Termites* (Eds. Krishna and Weesner) Vol. 2: 317, 339-340.
1971. Emerson, *Bull. Am. Mus. nat. Hist.*, (Art. 3): 248.
1973. Chhotani and Bose, *Zool. Anz.*, **190**(3/4): 234.
1974. Sen-Sarma, In *Ecology and Biogeography in India* (Ed. Mani): 453-454.
1977. Chhotani, *Proc. 8th int. Congr. Int. Un. Stud. Social Insects* (Sept. 1977, Wageningen): 116.
1983. Chhotani, *Orient. Insects*, **17**: 110, 112, 119.
1986. Grassé, *Termitologia* Vol. 3: 526.

Type-genus : *Termitogeton* Desneux.

## 1. Characters of Subfamily Termitogetoninae

*Imago* : Head subtriangular, flattened, almost as wide as long; very broad at vertex; posterior margin sharply and straightly cut; epicranial sutures distinct. Fontanelle present, with fontanelle gland. Eyes small somewhat projecting out; with large facets. Ocelli arched, separated from eyes. Postclypeus very short and flat; anteclypeus larger. Labrum convex, sloping in front. Mandibles each with an apical and 3 marginals; more or less like Heterotermitinae; 2nd marginal of left mandible longer than 1st. Antennae 15-segmented. Pronotum very small, flat; anterior margin strongly projected in front. Wings small, thickly hairy; forewing scale large.

Costa (subcosta + radius of Roonwal, Verma and Thakur 1979) thick, along anterior margin; subcosta absent; radius (radial sector and subcosta of some authors) simple, running close to and parallel with costa. Media absent or indistinct vide Holmgren 1911 p. 75, but in forewing of *Termitogeton planus* clearly shown by Roonwal, Verma and Thakur 1979 in fig. 11, p. 348, cubitus gives off a number of veins (6-8 branches) to posterior margin. Microsculpturing consists of small papillae (size  $3-6 \times 1.5$  to  $4.5 \mu\text{m}$ , density  $3200/\text{mm}^2$ ) present only on costa and radius and both nonasteroid and asteroid micrasters (size  $4-7 \times 4-5 \mu\text{m}$ , density  $7600/\text{mm}^2$ ) all over wing membrane, arranged in circles, oblongs and spirals. Abdomen broad, flattened. Legs with thick coxae, tibial spurs 3:2:2; claws long and narrow; cerci short, styli absent.

*Soldier* : Head dorso-ventrally flattened; triangular, broad posteriorly and narrowed in front; densely hairy; posterior margin incurved and bulging out medially; sides bow-shaped; epicranial sutures very distinct sometimes. Fontanelle small, circular, situated medially. Eyes and ocelli absent. Antennae with 13-15 segments. Clypeus short and flat; divided into an apilose ante- and a pilose postclypeus. Labrum triangular with a hyaline tip and with a pair of long bristles at base of tip. Mandibles sabre-shaped; both right and left with a small marginal tooth on inner margin near base. Postmentum club-shaped. Pronotum flat; front margin projected in front. Hind coxae thick; apical tibial spurs 3:2:2; claws thin and long. Abdomen oblong; cerci short; styli absent.

*Worker* : Head shape as in imago but very much rounded. Fontanelle plate present. Antennae 12-13 segmented. Clypeus, labrum and mandibles as in imago. Pronotum as in imago. Legs as in soldier.

## 2. *Distribution and Composition of Termitogetoninae*

*Distribution* : This subfamily is endemic to the Oriental Region. It is reported from Sri Lanka in the Indian Region and Sarawak and Sabah, Malaysia).

*Composition* : The subfamily comprises the single genus *Termitogeton* Desneux.

### Genus 17. *Termitogeton* Desneux

#### 1. Subgenus *Termitogeton* (of *Termes*) Desneux :

1904. Desneux, *Ann. Soc. Ent. Belg.*, **48**(10): 374.

1904. Desneux, *Genera Insect.*, Fasc. **25**: 29, 32, 46-47.

#### 2. Genus *Termitogeton* Desneux :

1911. Holmgren, *K. Sv. Vet. Akad. Handl.*, **46**(6): 75-76.

1911. Holmgren, In Escherich's *Termitenleben auf Ceylon*: 193-194.

1922. Hegg, *Les Termites* : 346-347.

1925. John, *Treubia*, **6**(3-4): 384.

1949. Snyder, *Smiths. misc. Colls.*, **112**: 84.

1950. Ahmad, *Bull. Am. Mus. nat. Hist.*, **95** (Art. 2): 54, 56.

1953. Rattan Lal and Menon, *Catal. Indian Insects, Pt. 27, Isoptera* : 33.

1955. Emerson, *Fieldiana : Zool.*, **37**: 509.

1955. Weidner, In *Die Termiten* (Ed. Schmidt): 10, 56.

1958. Ahmad, *Biologia*, Lahore, **4**(1 & 2): 59, 60, 73.

1970. Krishna, In *Biol. of Termites* (Eds. Krishna and Weesner) Vol. 2: 137, 138.

1970. Roonwal, In *Biol. of Termites* (Eds. Krishna and Weesner) Vol. 2: 339.

1971. Emerson, *Bull. Am. Mus. nat. Hist.*, **146**(Art. 3): 248, 251, 256.

1974. Sen-Sarma, In *Ecology and Biogeogr. in India* (Ed. M.S. Mani): 453-454.

1975. Emerson and Krishna, *Am. Mus. Novit.*, No. 2570: 16.

1979. Roonwal, Verma and Thakur, *Proc. Indian natnl. Sci. Acad.*, (B) **45**(4): 347.

1983. Chhotani, *Orient. Insects*, **17**: 111, 112, 114, 119.

1986. Grasse, *Termitologia* Vol. 3: 527.

#### 3. Genus *Termes* Linn. (Part) :

1860. Hagen, *Linn. Ent.*, **14**: 110.

1898. Haviland, *J. Linn. Soc. Lond.*, **26**(169): 397. (Sect. with *Termes planus* for type).

Type of genus : *Termes umbilicatus* Hagen.

#### 1. Characters of Genus *Termitogeton*

Same as in subfamily Termitogetoninae.

## 2. *Distribution and Composition of Termitogeton*

*Distribution* : Same as in subfamily Termitogetoninae.

*Composition* : The genus *Termitogeton* comprises three species viz., *planus* (Haviland) and *minor* Thapa from Sarawak and Sabah and *umbilicatus* (Desn.) from Sri Lanka.

### 79. *Termitogeton umbilicatus* (Hagen) (Figs. 265, 266)

#### 1. *Termes umbilicatus* Hagen :

1858. Hagen, *Zool. Bot. Ver. Wien*, 1858 : 472. Im, S, W. Holotype: Repository of types not known. Type-locality : Rambodde, Sri Lanka.

1860. Hagen, *Linn. Ent.*, 14: 110.

#### 2. *Termes (Termitogeton) umbilicatus* Hagen :

1904. Desneux, *Genera Insect.*, Fasc. 25: 47.

#### 3. *Termitogeton umbilicatus* (Hagen) :

1911. Holmgren, *K. Sv. Vet. Akad. Handl.*, 46(6): 75, 76.

1911. Holmgren, In Escherich's *Termitenleben auf Ceylon* : 193.

1913. Holmgren, *K. Sv. Vet. Akad. Handl.*, 50(2): 88, 90-91.

1914. Bugnion, *Ann. Soc. Ent. France*, 83(1): 39-47.

1922. Hegh, *Les Termites* : 346-347.

1949. Snyder, *Smiths. misc. Colls.*, 112: 85.

1958. Ahmad, *Biologia*, Lahore, 4(1-2): 73.

1970. Weidner, *Handb. d. zool.*, 4(2): 21.

1970. Roonwal, In *Biology of Termites* (Eds. Krishna and Weesner) Vol. 2: 339-340.

1983. Chhotani, *Orient. Insects*, 17: 113, 119.

1986. Grasse, *Termitologia* Vol. 3: 526.

IMAGO (Fig. 265) : Specimens not seen; description drawn from literature. Rust coloured; antennae darker, brownish; margins of pronotum, legs and abdomen from underneath paler, yellowish; wings ash-grey, marginal veins brownish. Body thickly and finely hairy. Total length with wings 8.0 and without wings 3.5 mm. Head triangular; strongly depressed

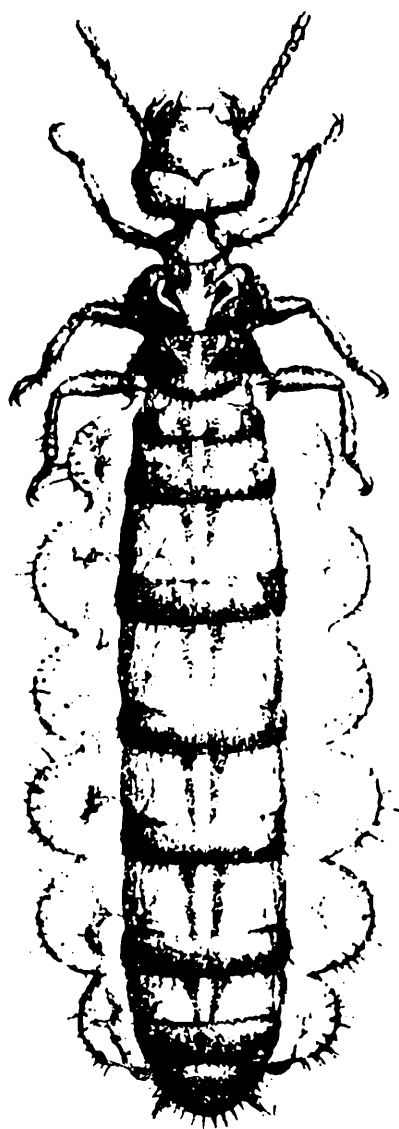

Fig. 265. *Termitogeton umbilicatus*. Queen, in dorsal view. (After Bugnion 1914.)

and flattened. Eyes of medium size, slightly bulging. Ocelli oval, situated near eyes. Antennae with 15 segments; slightly longer than head; moderately thick, getting thicker towards tip; segments 1-3 cylindrical; next five very small. Pronotum small, narrower than head; anterior margin projected in middle into pointed, acute tip like navel (umbilicate); side angles pointed; sides and posterior margin curved, crescent forming. Abdomen oval; abdominal appendages small. Legs short and thick. Wings 3 times as long as wide; with fine hairs; scales very small, triangular. Costa and radius moderately thick, close to each other; remaining veins fine, media indistinct.

**SOLDIER (Fig. 266)** Head-capsule, pronotum, body and legs pale golden to reddish yellow; mandibles light reddish brown, paler basally; antennae pale yellow. Head and body densely hairy. Total body-length 4.50-5.0 mm. Head triangularly oval; dorso-ventrally flattened; widest a little behind middle whence strongly narrowing in front; sides rounded; posterior margin incurved and with a median bulge; posterior angles sharp; length to base of mandibles 1.5-1.55, max. head-width 1.44-1.55 mm. Fontanelle small, round; situated on head in front of mid point. Eyes and ocelli absent. Antennae with 14-15 segments; segment 2 subequal to or longer than 3. **Postclypeus** subtrapezoidal, hairy; **anteclypeus** hyaline, thin, strip-like. Labrum leaf-shaped; tapering to a short, hyaline tip; much longer

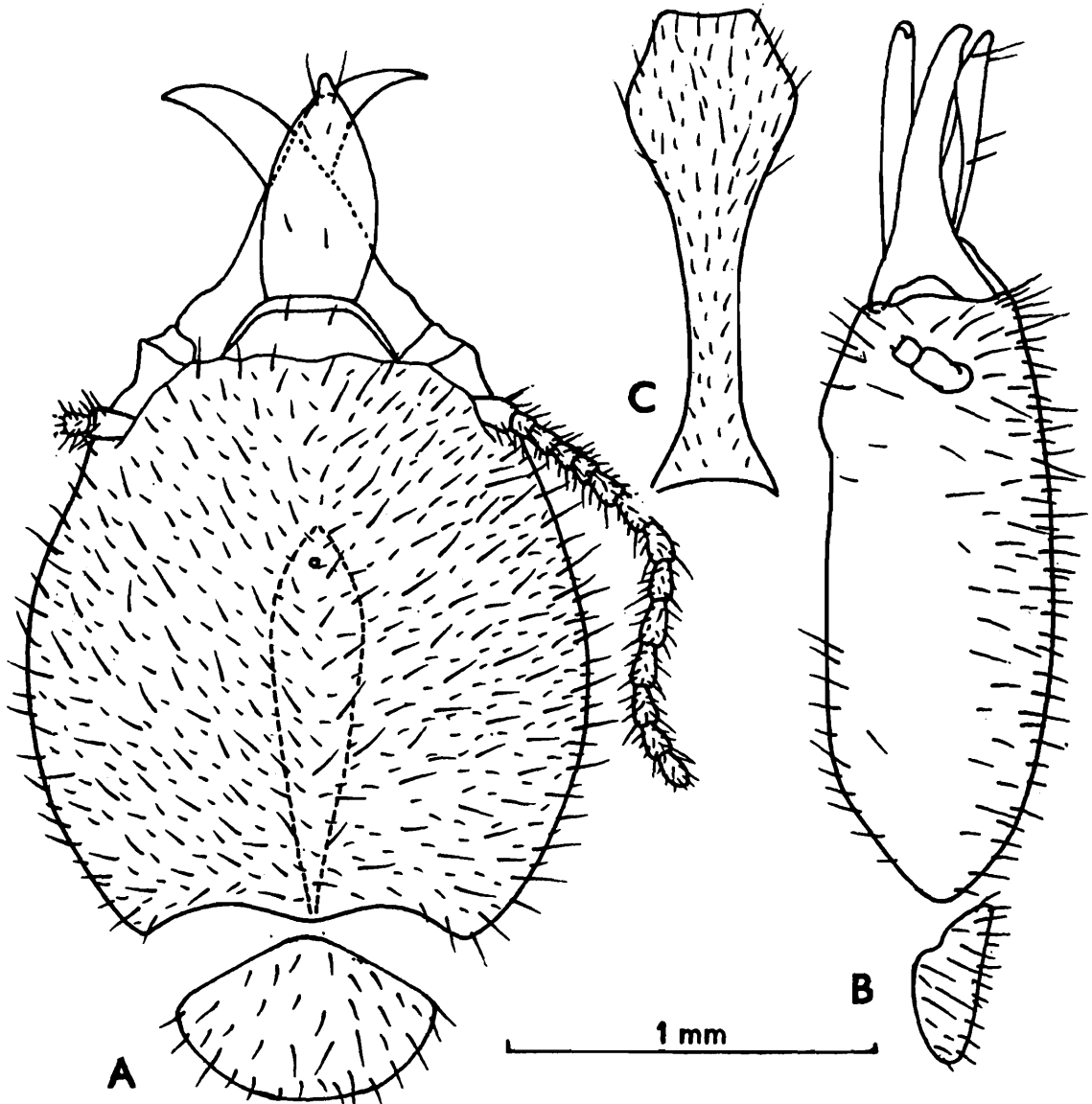

Fig. 266. *Termitogeton umbilicatus*. Soldier. (A) Head and pronotum, dorsal view. (B) Same, side view. (C) Postmentum.

than broad (length 0.65, width 0.35 mm). Mandibles fairly thick, sabre-shaped, strongly incurved at anterior end; 0.95-0.98 mm long; each mandible with one or 2 crenulations at basal broader portion. Postmentum club-shaped with a long and very narrow waist (length 1.25, max. width 0.43-0.45, width at waist 0.10-0.13 mm). Pronotum flat, subtriangular, fan-like; anterior margin projected in front strongly and sharply, without notch; posterior margin rounded (length 0.40-0.45, width 0.65 mm). Legs short and robust; dorsal spur of foretibia not distinct in specimens studied. Abdomen oval, elongate; cerci 2-jointed; styli not seen in specimens examined.

**WORKER** : Head yellowish white; body whitish. Head and body thickly hairy. Total body-length 3.5-3.9 mm. Head subtriangular, head-capsule subsquarish, flat, broad posteriorly; a little broader than length to base of mandibles (length 0.65-0.73, width 0.75-95 mm). Postclypeus flat, short, hairy. Labrum dome-shaped. Antennae with 15 segments; 3rd and 5th segments short and subequal. Mandibles as in genus. Pronotum as in soldier but less so projected in front (length 0.23-0.26, width 0.38-0.53 mm). Legs and abdomen as in soldier.

*Distribution* : SRI LANKA : Hantana, Rambodde, Peradeniya.

### Subfamily (v) RHINOTERMITINAE Froggatt

1. Subfamily Rhinotermitinae (of Termitidae) Froggatt :

1986. Froggatt, *Proc. Linn. Soc. N.S.W.*, 21: 539.

2. Subfamily Rhinotermitinae (of Mesotermitidae) Froggatt :

1911. Holmgren, *K. Sv. Vet. Akad. Handl.*, 46(6): 62, 63, 76-78.

1913. Holmgren, *K. Sv. Vet. Akad. Handl.*, 50(2): 78.

3. Subfamily Rhinotermitinae (of Rhinotermitidae) Froggatt :

1920. Banks, *Bull. U.S. natnl. Mus.*, No. 108 : 118.

1925. Sjöstedt, *K. Sv. Vet. Akad. Handl.*, 3(1): 51.

1934. Kemner, *K. Sv. Vet. Akad. Handl.*, 13(4): 50.

1949. Snyder, *Smiths. misc. Colls.*, 112: 85.

1950. Ahmad, *Bull. Am. Mus. nat. Hist.*, 95(Art. 2): 56.

1953. Rattan Lal and Menon, *Catal. Indian Insects, Pt. 27-Isoptera* : 32.

1955. Emerson, *Fieldiana : Zool.*, 37: 516.
1955. Weidner, In *Die Termiten* (Ed. Schmidt): 57-58.
1961. Harris, *Termites : Recognition & Control* : 38, 47-48. (Second edition 1971).
1970. Weidner, *Handb. d. Zool.*, 4(2): 11, 12.
1970. Roonwal, In *Biology of Termites* (Eds. Krishna and Weesner) Vol. 2: 137, 138-139.
1971. Emerson, *Bull. Am. Mus. nat. Hist.*, 146(Art. 3): 248.
1974. Sen-Sarma, In *Ecology & Biogeography in India* (Ed. Mani) : 454.
1977. Chhotani, *Proc. 8th int. Cong. Int. Un. Study Social Insects* (Wageningen, Sept. 1977) : 117.
1979. Roonwal, Verma and Thakur, *Proc. Indian natnl. Sci. Acad.*, (B) 45(4): 350, 351.
1983. Roonwal, *Proc. Indian natnl. Sci. Acad.*, (B) 49(5): 363, 367, 379, 387.
1983. Chhotani, *Orient. Insects*, 17: 111, 112, 113, 119.
1985. Chhotani, *Z. ang. Ent.*, 100: 93-94.
1986. Grassé, *Termitologia* Vol. 3: 529-530.
4. Subfamily Arrhinotermitinae Sjöstedt:
1925. Sjöstedt, *K. Sv. Vet. Akad. Handl.*, (1): 54.

Type genus : *Rhinotermes* Hagen

### 1. Characters of Subfamily Rhinotermitinae

*Imago* : Head large, subcircular with a median groove running from fontanelle to labrum. Postclypeus well developed, swollen. Fontanelle open, with gland. Eyes moderately large, bulging. Ocelli generally large, separated from eyes. Antennae with 17-20 segments, segment 3 longer than 2. Labrum very broad, strongly convex, inclined. Mandibles each with an apical and 3 marginal teeth; 2nd marginal of left mandible shorter than 1st except in *Prorhinotermes* where it is larger; right mandible generally as in family Rhinotermitidae. Pronotum flat, large, width twice its length; anterior and posterior margins substraight. Wings short and broad, reticulate; generally hairless or with a few odd hairs; media separate, free in forewing with 3-5 branches, close to cubitus and coming out of radius just outside scale in hindwing; cubitus with 10 to 20 branches. Anterior 2 veins, viz., costa and radius thick and brown, without branches. Forewing scale larger than hindwing scale. Microsculpturing consists of four types of

elements viz. papillae, pimpules, arrowheads and tubercles in different combinations. Legs with 3:2:2 apical tibial spurs; dorsal spur of foreleg sometimes rudimentary (*Parrhinotermes*).

*Note on wing microsculpturing* : Wings are generally without or sometimes with a few hairs; both sides of the wing-surface are covered with microsculpturing elements of four types, namely papillae, pimpules, arrowheads and tubercles in various combinations as follows :

Papillae only (some *Schedorhinotermes*); papillae and arrowheads (*Prorhinotermes*); papillae and pimpules (Some *Schedorhinotermes* and *Rhinotermes*); and papillae, pimpules and tubercles (*Dolichorhinotermes*). (Roonwal, Verma and Thakur, 1979 and Roonwal, 1983.)

*Soldier* : Dimorphic or monomorphic. Dimorphic in *Schedorhinotermes*, *Rhinotermes*, *Dolichorhinotermes* and *Acorhinotermes* and monomorphic in *Prorhinotermes* and *Parrhinotermes*. Head short and broad, narrowed in front. Postclypeus short, faintly demarcated from frons. Labrum differently developed in different species; either long or broad or very narrow; having a hyaline apex, a dorsal groove and bifid tip. Fontanelle large to very large; fontanelle gland extending into abdomen; fontanelle position variable, either in normal position or projecting in front; from fontanelle a groove goes to clypeus or sometimes to labrum tip. Eyes absent or faintly present. Antennae with 13-19 segments. Mandibles strong, weakly to strongly incurved, more or less without teeth or with a few crenulations; left mandible toothless (*Prorhinotermes*) or with 2 prominent teeth; right mandible either toothless (*Prorhinotermes*) or with 1 or 2 prominent teeth. Postmentum club-shaped or subrectangular with a bulge in middle. Pronotum always flat and transversely oval. Legs with 3:2:2 apical tibial spurs. Soldier minor, when present, generally as soldier major but with narrower and more convergent head, longer labrum, more strongly curved and thinner mandibles and in having antennae with 13-17 segments, and mandibles sometimes very small and reduced (*Acorhinotermes* and *Rhinotermes*).

*Worker* : Head rounded. Clypeus short, somewhat swollen, with a median line. Eyes absent or weakly marked. Fontanelle gland present. Mandibles as in Imago. Antennae with 13-18 segments. Pronotum flat or saddle-shaped. Legs with 3:2:2 apical tibial spurs. Styli present or absent.

## 2. *Distribution and Composition of Rhinotermitinae*

**Distribution :** The subfamily Rhinotermitinae is distributed all over the world. Genus *Parrhinotermes* from the Oriental (Sarawak, Sabah, Kalimantan, Sumatra, China and India) and Australian (Queensland) regions; *Schedorhinotermes* from the Oriental (S.E. Asia, China, India, Burma), the Australian, the papuan and the Ethiopian regions; *Prorhinotermes* from the Oriental (India, Sri Lanka, Bangladesh, Thailand, Philippines, Krakatau, etc.), the Papuan, the Malagasy, the Neotropical and the Nearctic regions and in the latter region it is found only in Florida U.S.A.; *Macrorhinotermes* from the Oriental (SE Kalimantan); and the genera *Acorhinotermes*, *Dolichorhinotermes* and *Rhinotermes* in the Neotropical Region only.

**Composition :** The subfamily comprises 7 genera namely, *Prohinotermes*, *Parrhinotermes*, *Schedorhinotermes*, *Macrorhinotermes*, *Acorhinotermes*, *Dolichorhinotermes* and *Rhinotermes* and of these, the first three occur in the Indian Region.

**Note on genus *Prorhinotermes* :** Quennedey and Deligne (1975) have separated the genus *Prorhinotermes* Silvestri and placed it in a new subfamily Prorhinotermitinae mainly because of the absence of the "daubing brush" on the soldier labrum which is present in all other genera of the family.

Grasse' (1986, p. 524) has discussed the taxonomic status of the new subfamily and concluded that its separation is unsatisfactory although he has adopted it as the fourth subfamily of Rhinotermitidae. Curiously, however, he has placed genus *Prorhinotermes* Silvestri in both *Prorhinotermitinae* (p. 524) and the *Rhinotermitinae* (p. 529). We are of the opinion that it is best to retain *Prorhinotermes* in the subfamily Rhinotermitinae.

## 3. *Keys to the Indian Region Genera of Rhinotermitinae*

### IMAGOES

- |   |                       |
|---|-----------------------|
| 1(2) 2nd marginal tooth of left mandible longer than 1st. Postclypeus fairly enlarged, without a distinct median groove from fontanelle to labrum. ....                                 | <i>Prorhinotermes</i> |
| 2(1) 2nd marginal of left mandible shorter than 1st. Postclypeus considerably enlarged and anteriorly produced, with a distinct median groove running through from fontanelle to labrum |                       |

- 3(4) Antennae 20-segmented ..... *Schedorhinotermes*  
 4(3) Antennae 16 to 17-segmented ..... *Parrhinotermes*

### SOLDIERS

- 1(2) Mandibles without distinct teeth; only a few crenulations in basal portion may be present. Anterior margin of pronotum not projected in front medially. Labrum without fringe of hairs or "daubing brush" ..... *Prorhinotermes*  
 2(1) Mandibles with distinct teeth. Anterior margin of pronotum somewhat to prominently projected in front medially. Labrum with a prominent fringe of hairs or "daubing brush"  
 3(4) Monomorphic. Mandibles finely serrated basally ..... *Parrhinotermes*  
 4(3) Dimorphic. Mandibles not serrated basally ..... *Schedorhinotermes*

### Genus 18. *Prorhinotermes* Silvestri

(Synonyms : *Arrhinotermes* Wasmann, *Procoptotermes* Holmgren, *Paratermes* Oshima and *Termitogetonella* Oshima)

#### 1. Genus *Prorhinotermes* Silvestri :

1909. Silvestri, In Michaelsen's and Hartmeyer's, *Fauna Südwest-Austral.* Vol. 2 : 286.  
 1919. Banks, *Bull. Mus. Comp. Zool. Harvard Coll.*, 62(10): 479.  
 1920. Banks and Snyder, *Bull. U.S. natn. Mus.*, No. 108: 39, 145.  
 1921. Light, *Philipp. J. Sci.*, 19 (1) : 48.  
 1949. Snyder, *Smiths. misc. Colls.*, 112 : 85.  
 1950. Ahmad, *Bull. Am. Mus. nat. Hist.*, 95(Art.2): 53, 54, 56.  
 1955. Emerson, *Fieldiana : Zool.*, 37: 471, 478-479, 488, 489, 493, 500, 509.  
 1955. Weidner, In *Die Termiten* (Ed. Schmidt): 57, 70.  
 1958. Ahmad, *Biologia*, Lahore, 4(1-2): 59, 60.  
 1961. Harris, *Termites : Recognition & Control*: 47-48. (2nd edition 1971)  
 1965. Ahmad, *Bull. Am. Mus. nat. Hist.*, 131 (Art.1): 8.  
 1971. Emerson, *Bull. Am. Mus. nat. Hist.*, 146 (Art. 3): 248, 250, 251, 257, 258, 259, 260, 262.  
 1973. Chhotani and Bose, *Zool. Anz.*, 190(3-4): 233, 234.  
 1975. Emerson and Krishna, *Am. Mus. Novit.*, No. 2570: 12, 13, 14, 15, 16, 17, 18, 19, 20, 21, 22.

1975. Akhtar, *Bull. Dept. Zool. Univ. Panjab, (N.S.)*, Art. 7: 35, 36.
1976. Bose and Maiti, *Newslet. zool. Surv. India*, 2(1): 15-16.
1977. Araujo, *Catal. Isoptera Novo Mundo*: 27.
1979. Roonwal, Verma and Thakur, *Proc. Indian natnl. Sci. Acad.*, (B) 45 (4): 334, 335, 351.
1982. Thapa, *Sabah For. Rec.*, No. 12: 4, 5.
1983. Roonwal, *Proc. Indian natnl. Sci. Acad.*, (B) 49(5): 363.
1983. Chhotani, *Orient. Insects*, 17 : 111, 112, 113, 114, 119.
1984. Bose, *Occ. Pap. Rec. Zool. Surv. India*, No. 49: 71, 77, 78, 88.
1986. Grassé, *Termitologia* Vol. 3: 524.
2. Subgenus *Rhinotermes* (of *Termes*) Hagen (Part):
1858. Hagen, *Linn. Ent.*, 12: 107-108, 233.
1858. Hagen, *Catal. Specimens Neuropterous Insects Coll. Brit. Mus. Part 1. Termitina*: 16, 33.
3. Genus *Arrhinotermes* Wasmann (Part):
1902. Wasmann. *Zool. Jb.*, 17(1): 103, 139, 160.
1911. Holmgren, *Zool. Anz.*, 37(26): 548, 549.
1911. Holmgren, *K. Sv. Vet. Akad. Handl.*, 46(6): 71-72, 74.
1913. Holmgren, *K. Sv. Vet. Akad. Handl.*, 50(2): 66.
4. Subgenus *Arrhinotermes* (of *Termes*) Wasmann:
1904. Desneux, *Genera Insect.*, Fasc. 25: 31, 33-34.
5. Genus *Termes* Linn. (Part):
1904. Sjöstedt, *K. Sv. Vet. Akad. Handl.*, 38(4): 47.
6. Subgenus *Termes* (of *Termes*) Linn. (Part) :
1904. Desneux, *Genera Insect.*, Fasc. 25: 32, 35-46.
7. Genus *Procoptotermes* Holmgren:
1909. Holmgren, *K. Sv. Vet. Akad. Handl.*, 44(3): 25, 110, 169. (No description.)
1911. Holmgren, *K. Sv. Vet. Akad. Handl.*, 46(6): 73. (No description.)
8. Genus *Paratermes* Oshima:
1912. Oshima, *Third Official Rept. Termites* : 69.
9. Genus *Termitogetonella* Oshima:
1920. Oshima, *Philipp J. Sci.*, 17(5): 496.

Type of genus *Prorhinotermes inopinatus* Silvestri.

### 1. *Characters of Genus Prorhinotermes*

*Imago* : Head and pronotum reddish yellow to reddish brown. Head broadly oval to nearly circular, moderately swollen. Fontanelle situated in centre of head. Postclypeus relatively large, swollen, with or without a median groove. Antennae 19 to 22-segmented. Mandibles typically Rhinotermitid; second marginal tooth of left mandible distinctly longer than 1st. Pronotum less than to a little broader than head. Forewing scale larger than hindwing scale. Wing membrane weakly hairy, strongly reticulate. Media of both fore-and hindwings coming out of cubitus or is not separated from cubitus, in which case media is absent. Wing microsculpturing consists of 2 elements, i.e. finger-shaped or subcrescentic papillae on the anterior and other veins and arrowheads of different shapes, curved { -shaped and merging gradually into the subcrescentic form in posterior half of front veins. Legs with 3:2:2 apical tibial spurs.

*Soldier* : Head oval, distinctly narrowed in front, sparsely pilose. Eyes present. Fontanelle small, situated a little in front of middle on upper side of head; from fontanelle a small, clear groove runs in front to clypeus; fontanelle gland large, stretching back into abdomen. Antennae with 16-19 segments. Mandibles well developed without clear teeth. Postmentum long, club-shaped. Pronotum flat. Apical tibial spurs 3:2:2.

*Worker* : Head subcircular. Postclypeus moderately large. Eyes present or absent. Mandibular teeth of workers same as in imago. Pronotum and legs as in soldier.

### 2. *Distribution and Composition of Prorhinotermes*

*Distribution*(Fig. 217) : The genus *Prorhinotermes* is known from the Oriental, the Papuan, the Malagasy and the Neotropical, regions; one Neotropical species, however, extends into Florida, U.S.A. in the Nearctic region. It is mainly Oriental (7 out of 13 species) and is essentially insular in distribution, with a very few records (Ahmad 1965, Bose and maiti, 1976) from the mainland.

*Composition* : The genus *Prorhinotermes* is known by 13 species, of which seven are from the Oriental Region and only one, namely *flavus* Bugnion & Popoff, is known from the Indian Region.

**80. *Prorhinotermes flavus* (Bugnion and Popoff)**(Syn. *P. shiva* Roonwal and Thakur)

(Fig. 267)

**1. *Coptotermes flavus* Bugnion and Popoff:**1910. Bugnion and Popoff, *Mem. Soc. Zool. France*, 23(8): 117-120. S and W. Holotype: Repository not known. Type-locality : Ambalangoda, Sri Lanka.1911. Bugnion and Ferriere, *Mem. Soc. Zool. France*, 24(1/2): 97-106.**2. *Arrhinotermes flavus* (Bugnion and Popoff) :**1911. Holmgren, *K. Sv. Vet. Akad. Handl.*, 46(6) : 72.1911. Holmgren, *Zool. Anz.*, 37(26) : 551.1913. Holmgren, *K. Sv. Vet. Akad. Handl.*, 50(2) : 66, 67-68.1913-14. Holmgren, *Zool. Jahrb. (Syst.)*, 36(2-3) : 253.1925. John, *Treubia*, 6(3-4) : 281.**3. *Prorhinotermes flavus* (Bugnion and Popoff) :**1949. Snyder, *Smiths, misc. Colls.*, 112 : 86.1958. Ahmed, *Biologia*, Lahore, 4(1 and 2) : 74, 75.1963. Roonwal and Thakur, *Indian J. agric. Sci.*, 33(2): 109.1965. Ahmed, *Bull. Am. Mus. nat. Hist.*, 131 (Art. 1) : 23.1966. Roonwal and Maiti, *Treubia*, 27(1) : 89.1970. Roonwal and Bose, *Rec. zool. Surv. India*, 62(3 & 4) : 119.1970. Roonwal, In *Biology of Termites* (Eds. Krishna and Weesner) Vol. 2 : 340.1976. Bose and Maiti, *Newsl. zool. Surv. India*, 2(1) : 15-16.1980. Bose, *Rec. zool. Surv. India*, 77 : 99-100.1983. Chhotani, *Orient. Insects*, 17: 119.1984. Bose, *Occ. Pap. Rec. zool. Surv. India*, No. 49:71, 89-90.**4. *Prorhinotermes shiva* Roonwal and Thakur. New Synonymy :**1963. Roonwal and Thakur, *Indian J. agric. Sci.*, 33 : 102-109. S,W. Holotype : S, in ZSI. Type-locality : Long Island, Middle Andamans, India.1966. Roonwal and Maiti, *Treubia*, 27(1) : 89, 90. (Missplet as *siva*.)1970. Roonwal and Bose, *Rec. zool. Surv. India*, 62 : 117, 119.1975. Akhtar, *Bull. Dept. zool. Univ. Panjab, (N.S.)*, Lahore, Art. 7 : 49-52.1977. Chhotani, *Occ. Pap. Rec. zool. Surv. India*, No. 9 : 30.1983. Chhotani, *Orient. Insects*, 17:119.

**IMAGO (Fig. 267A) :** Head and pronotum yellowish to reddish brown; body pale yellow. Wings hyaline, scantily pilose. Total length with wings c 11.0 and without wings c 8.0 mm. Head broadly oval (head-width with eyes 1.36-1.50, head-length to base of mandibles 1.18-1.4 mm). Fontanelle open, circular, prominent; situated anterior to middle; with a groove leading up to base of postclypeus; fontanelle gland large. Eyes of medium size, subcircular (maximum diameter 0.34-0.38 mm); moderately bulging. Ocelli oval, of medium size (length 0.14-0.17, width 0.10-0.11 mm); touching or slightly separated from eyes. Antennae with 19-20 segments; segment 3 slightly shorter than 2; 4 subequal to or slightly shorter than 3. Postclypeus weakly pilose, swollen; moderately large, length half of width;

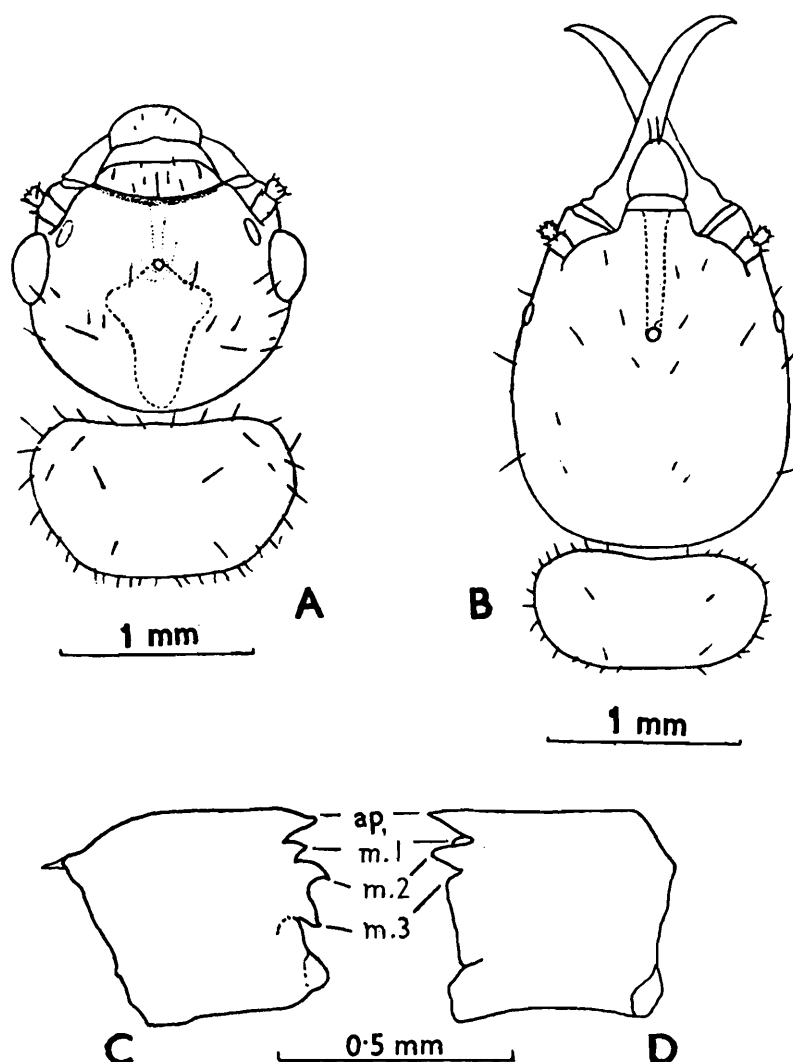

Fig. 267. *Prorhinotermes flavus*. Imago, soldier and worker. (A) Head and pronotum of imago, dorsal view. (B) Same, soldier. (After Bose, 1984.) (C) and (D) Left and right mandibles of worker.

medially divided by an incomplete line. Anteclypeus apilose, hyaline; weakly projected in front. Labrum dome-shaped, rounded anteriorly; with a few hairs medially, broader than long. Mandibles as in genus. Pronotum flat; hairy along margins and with a few hairs on disc; almost as wide as head (width 1.25-1.4, length 0.75-0.80 mm); anterior margin faintly to fairly incurved; posterior margin substraight or slightly rounded; sides rounded. Legs with 3:2:2 apical tibial spurs. Wings hyaline, strongly reticulate. Media arising from cubitus at proximal third in forewing and near middle in hindwing. Cubitus with 14-16 branches. Abdomen broad in middle; cerci 2-segmented; styli present in male.

**SOLDIER (Fig. 267B) :** Head capsule, postclypeus, labrum and bases of mandibles golden yellow; mandibles apically dark reddish brown; antennae, legs and abdomen light brownish yellow. Head and body sparsely hairy. Total length 5.00-8.50 mm. Head-capsule oval, dorso-ventrally flat; much longer than broad, length to base of mandibles 1.55-1.90, width 1.21-1.60 mm; index Width/Length 0.764-0.831. Fontanelle open, circular; situated in anterior part of head dorsum; with a groove running in front upto postclypeus. Eyes oval, translucent, maximum diameter 0.10-0.20 mm. Ocelli absent. Antennae with 16-19 segments, segment 3 and 4 variable in size. Postclypeus not clearly demarcated from frons. Anteclypeus hyaline, whitish. Labrum broad, rounded anteriorly; length 0.23-0.30, width 0.25-0.33 mm. Mandibles long, sabre-shaped (length 0.90-1.20 mm); tips pointedly turned inwards. Postmentum club-shaped, waist at mid-point between maximum width and posterior margin (length 0.91-1.27, maximum width 0.43-0.53, width at waist 0.20-0.30 mm). Pronotum flat, subrectangular; much broader than long (width 1.05-1.27, length 0.55-0.70 mm); sides rounded to shorter substraight posterior margin; anterior margin weakly to appreciably notched medially. Legs long, apical tibial spurs 3:2:2. Cerci 2-segmented, short.

**WORKER (Fig. 267 C&D) :** Head, postclypeus and labrum pale golden yellow; antennae and abdomen paler. Head and body fairly pilose. Total body-length 4.0-5.0 mm. Head-capsule circular, broader than long (width 1.25-1.35, length to base of mandibles 1.03-1.05 mm). Postclypeus swollen, with a median line; width more than twice length. Anteclypeus narrow with pointed medial tip. Labrum and mandibles as in imago. Pronotum

subrectangular; with concave, medially emarginate anterior margin; posterior margin substraight. Legs as in soldier, somewhat shorter.

*Distribution* : *P. flavus*, in the Indian Region, is reported from Sri Lanka, India (Mangalore, Western coast; Andaman and Nicobar Islands) and Bangladesh.

*Remarks* : It is a very variable species. In a collection from Sri Lanka the head-length of soldier varied from 1.60-1.90 mm and head-width from 1.30-1.60 mm. Measurements of soldier of *P. shiva* as given by Roonwal and Thakur (1963) and Akhtar (1975) fall well within this range. In another collection of the species from Mangalore, Western coast, a lot of variation was found in size and in the shape of pronotum and in the concavity of its anterior margin, the characters used for separation of *shiva* from *flavus*. Since these characters are variable *shiva* is treated here as a synonym of *flavus*.

### Genus 19. *Parrhinotermes* Holmgren

#### 1. Genus *Parrhinotermes* Holmgren :

- 1910. Holmgren, *Zool. Anz.*, 35:285.(No description.)
- 1911. Holmgren, K. Sv. Vet. Akad. Handl., 46(6):77, 78.
- 1913-14. Holmgren, *Zool. Jb. (Syst.)*, 36(2-3):237.
- 1962. Roonwal and Chhotani, *Proc. natnl. Inst. Sci. India*, (B) 28(4):294.
- 1942. Hill, *Termites (Isoptera) from Australian Region* : 172.
- 1949. Synder, *Smiths. misc. Colls.*, 112 : 85.
- 1950. Ahmad, *Bull. Am. Mus. nat. Hist.*, 95(Art.2) : 54, 56.
- 1955. Emerson, *Fieldiana : Zool.*, 37 : 500, 509.
- 1955. Weidner, In *Die Termiten* (Ed. Schmidt) : 57.
- 1958. Ahmad, *Biologia*, Lahore, 4 (1 & 2): 59, 60.
- 1961. Harris, *Termites: Recognition and Control*: 48. (2nd Ed. 1971).
- 1970. Krishna, In *Biology of Termites* (Eds. Krishna and Weesner): Vol. 2: 137, 139.
- 1970. Roonwal, In *Biology of Termites* (Eds. Krishna and Weesner): Vol. 2: 340-341.
- 1970. Weidner, *Handb. d. zool.*, 4 (2): 21.
- 1971. Emerson, *Bull. Am. Mus. nat. Hist.*, 146 (Art. 3): 248, 251, 256.
- 1973. Chhotani and Bose, *Zool. Anz.*, 190 (3/4): 233, 234.

1982. Thapa, *Sabah For. Rec.*, No. 12: 5.

1982. Tsai and Huang, *Acta Ent. Sinica*, 25: 306-310.

1983. Chhotani, *Orient. Insects*, 17: 111, 112, 113, 114, 115, 119.

1985. Chhotani, *Z. ang. Ent.*, 100: 91, 93, 94.

1986. Grassé, *Termitologia*, Vol. 3: 529.

2. Genus *Termes* Linn. (Part):

1898. Haviland, *J. Linn. Soc. London*, 26(169): 378, 395. Section with *Termes aequalis* for type.)

Type of genus *Termes aequalis* Haviland.

### 1. Characters of genus *Parrhinotermes*

*Imago* : Head subcircular, somewhat flat. Fontanelle open, situated forwardly; with a faint shallow groove running from fontanelle to postclypeus. Eyes large, round, prominently projecting out. Ocelli either absent or broadly oval and close to eyes. Antennae with 16-17 segments. Postclypeus short, with a median line; length less than half of width. Labrum short, wide and inclined in front. Mandibles each with an apical and 3 marginals. Left mandible: Apical finger-like; first marginal subequal to apical; 2nd short; 3rd subequal to 2nd but with long anterior margin. Right mandible: Apical as in left mandible; 1st marginal rudimentary, lying at base of 2nd marginal; latter (2nd) subequal to apical; 3rd short with long posterior margin subequal to molar plate. Pronotum flat, narrower than head. Legs thin, long; apical tibial spurs very probably 3:2:2, not seen by us; Hill (1942) gives 2:2:2. Cerci 2-jointed; styli absent.

*Soldier* : Monomorphic. Head oval, narrowed in front, flat. Fontanelle forwardly placed near to clypeus, opening round to oval; with fontanelle gland and a groove running from fontanelle to apex of labrum. Postclypeus flat. Eyes and ocelli absent. Antennae with 13 segments. Labrum tongue-shaped, longer than broad; anterior margin hyaline, with a "daubing brush" of hairs. Mandibles long, narrow to fairly thick and stout; with tips long, narrow and sharply bent inwards; basal half with saw-like serrations. Left mandible with 2 forwardly pointed, sharp marginal teeth situated in anterior half. Right mandible with one sharp, forwardly directed marginal tooth situated in distal half. Pronotum small, anteriorly convex, posteriorly faintly

concave. Apical tibial spurs 3:2:2, dorsal spur small rudimentary; not 2:2:2 as given by some authors. Cerci short, 2-segmented; styli absent.

*Worker* : Head rounded, flattened. Fontanelle indistinct. Eyes and ocelli absent. Labrum and mandibles as in imago. Antennae with 13 segments. Pronotum strongly saddle shaped.

## 2. *Distribution and Composition of Parrhinotermes*

*Distribution* : The genus *Parrhinotermes* is known from the Oriental, the Australian and the Papuan zoogeographical regions. In the Oriental Region it is known from Malaysia (Sarawak, Sabah, Malaya), Indonesia (Sumatra), India (North-eastern India) and southern China.

*Composition* : The genus is known by nine species and subspecies out of which eight occur in the Oriental Region. From the Indian region, only one species i.e., *P. khasii* Roonwal and Sen-Sarma is reported and discussed.

### 81. *Parrhinotermes khasii khasii* Roonwal and Sen-Sarma (Figs. 268, 269)

#### 1. *Parrhinotermes khasii* Roonwal and Sen-Sarma :

1956. Roonwal and Sen-Sarma, *Indian, J. Agric. Sci.*, 26(1): 5, 6-11. S and W.

Holotype: S, in ZSI. Type-locality: Collecting Station No. 14, Bank of Nong-Priang Stream, Khasi Hills\*, Meghalaya, India. Type-examined.

1962. Roonwal and Chhotani, *Proc. natnl. Inst. Sci. India*, (B) 28(4): 288, 310-312.

1977. Lahiri, Ghosh and Biswas, *Bull. Meghalaya Sci. Soc.*, 2: 36.

1983. Chhotani, *Orient. Insects*, 17: 119.

#### 2. *Parrhinotermes khasii khasii* Roonwal and Sen-Sarma :

1982. Tsai and Huang, *Acta ent. Sinica*, 25: 306-310.

**IMAGO** : Unknown.

**SOLDIER** (Fig. 268) : Head-capsule yellowish brown; body and legs pale yellow; mandibles darker than head with blackish tips. Head and body

---

\*Khasi Hills are in Meghalaya, not in Arunachal Pradesh (= North East Frontier Agency) as mentioned by Roonwal and Sen-Sarma 1960.

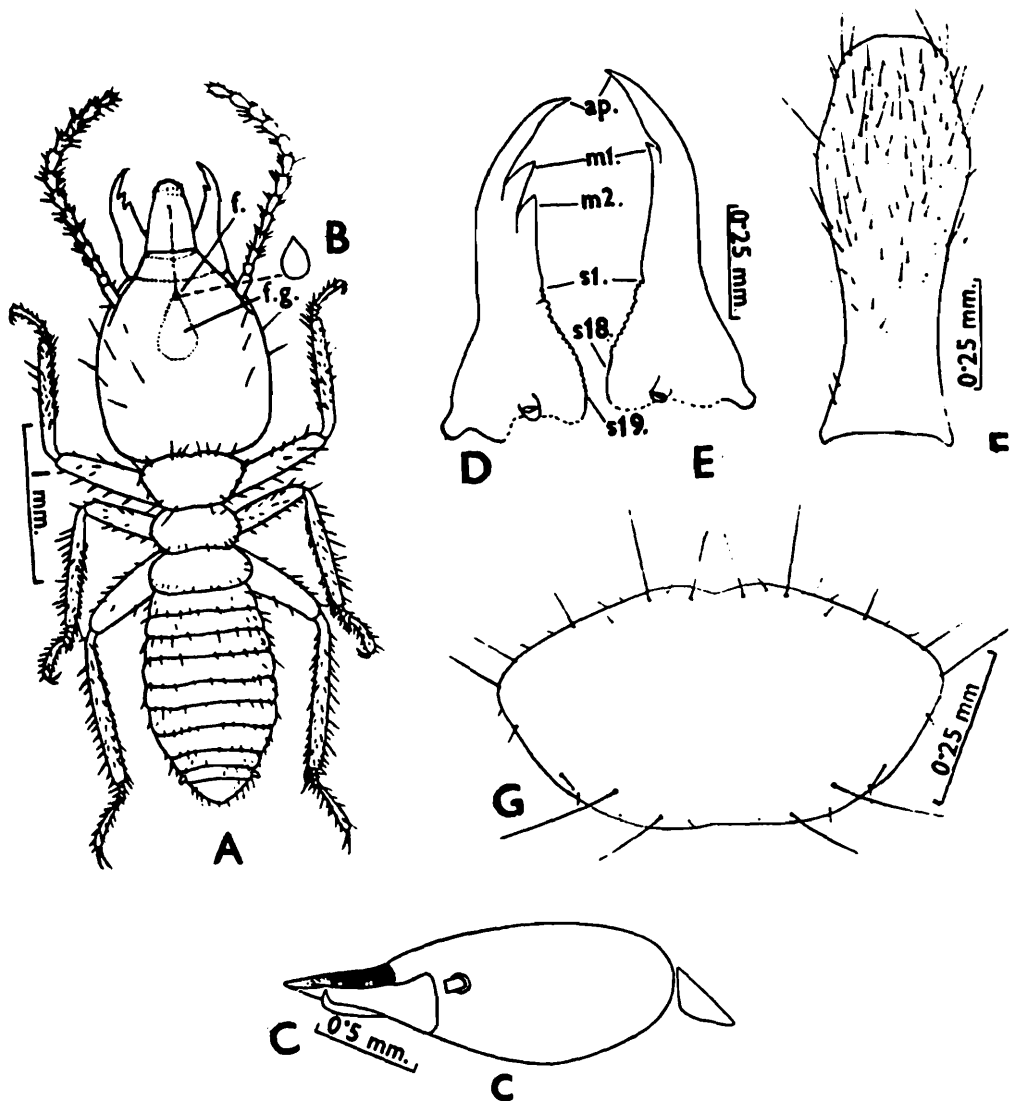

Fig. 268. *Prorhinotermes khasii. khasii*. Soldier. (A) whole specimen, dorsal view. (B) fontanelle enlarged. (C) Head and pronotum, side view. (D) and (E) Left and right mandibles. (F) Postmentum. (G) Pronotum.

ap., apical tooth; ft., fontanelle; f.g., fontanelle gland; m<sub>1</sub>, m<sub>2</sub>, 1st and 2nd marginal teeth; S<sub>1</sub>-S<sub>19</sub>, serrations 1-19. (Redrawn from Roonwal and Sen-Sarma 1956.)

fairly pilose. Total body-length 3.80-4.50 mm. Head-capsule pilose with a few bristles and very short hairs all over; large, subsquarishly oval, longer than broad (length to base of mandibles 1.20-1.32, max. width 1.02-1.14 mm); broadest in middle and with substraight posterior margin. Fontanelle small, pear-shaped; lying near clypeus; a narrow groove leading from opening to base of hyaline tip of labrum; fontanelle gland large and fusiform. Postclypeus small, not swollen; anteclypeus narrow, apilose.

Antennae with 13 segments; segment 2 shortest; 3 and 4 subequal. Eyes and ocelli absent. Labrum elongate, rectangular, finger-shaped, much longer than broad (length 0.48, width 0.30-0.36 mm); almost covering mandibles; with a blunt and broadly rounded hyaline tip; a few long bristles at base of hyaline part and a dense row of hairs forming a fringe or "daubing brush" along the anterior margin of tip. Mandibles long (0.66-0.78 mm), sabre-

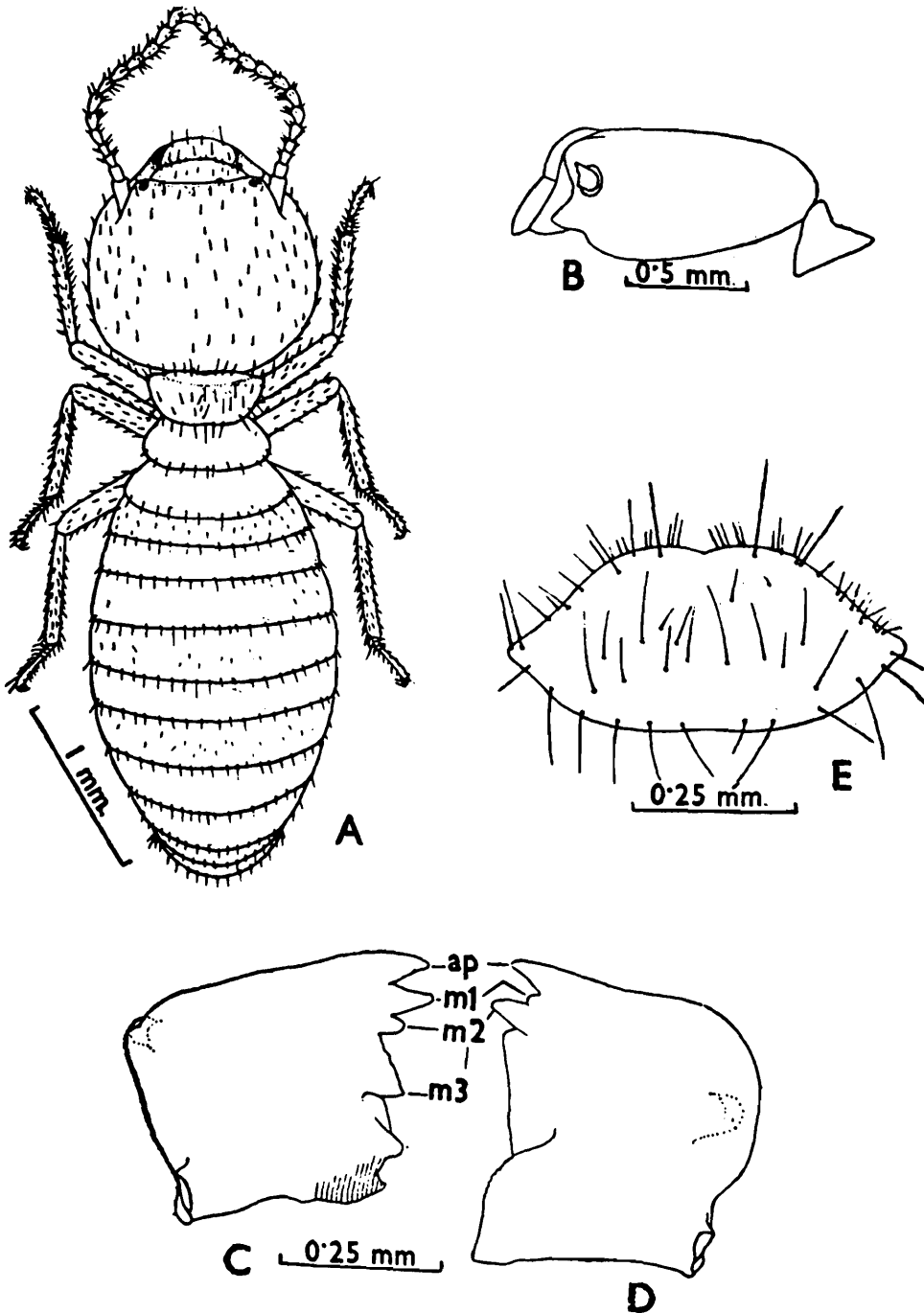

Fig. 269. *Prorhinotermes khasii khasii*. Worker. (A) Whole specimen, dorsal view. (B) Head and pronotum, side view. (C) and (D) Left and right mandibles. (E) Pronotum. ap., apical tooth; m<sub>1</sub>, m<sub>2</sub>, and m<sub>3</sub>, first, second and third marginal teeth. (Redrawn from Roonwal and Sen-Sarma 1956.)

shaped; tips sharply pointed inwards; with fine serrations in basal half of inner margin. Left mandible with two marginal teeth in distal half. Right mandible with one sharp, marginal tooth in distal one-third. Postmentum fairly pilose, long (length 0.90-1.08 mm), club-shaped; with a bulge at widest width (0.30-0.36 mm) at anterior one third from whence sides converging to a convexical anterior margin and posteriorly converging gradually to a waist (minimum width at waist 0.18 mm); posterior margin weakly concave. Pronotum sparsely pilose, flat, trapezoid, broader than long (width 0.66-0.72, length 0.36-0.48 mm.); anterior margin convex with a sharp median notch; posterior margin substraight with weak median notch. Legs slender, apical tibial spurs' 3:2:2 (dorsal spur in foreleg small, rudimentary; sometimes not discernible). Cerci short, 2 segmented.

WORKER (Fig, 269) : Larger in size than soldier. Total length 4.41-4.77 mm. Head- capsule pale yellowish, rounded (length to base of mandibles 1.02-1.14, width 1.14-1.20 mm); dorso-ventrally flattened; pilose with short, fine hairs. Fontanelle, eyes and ocelli absent. Labrum pilose, subsquarish (length 0.42, width 0.42 mm); with rounded distal end. Antennae with 13 segments. Mandibles as in genus. Pronotum saddle-shaped, pilose, much smaller than head (width 0.60-0.66, length 0.24-0.30 mm); anterior margin with a median invagination, posterior margin substraight. Legs as in soldier.

*Distribution* : The species (s. str.) is known from North-eastern India (Meghalaya and Arunachal Pradesh. A subspecies *P. khasii ruiliensis* has recently been described from Ruili Xian, China by Tsai and Huang (1982).

### Genus 20. *Schedorhinotermes* Silvestri

#### 1. Subgenus *Schedorhinotermes* (of *Rhinotermes*) Silvestri :

1909. Silvestri, In Michaelsen's and Hartmeyer's, *Die Fauna Südwest-Australia* Vol. 2: 289.

1911. Holmgren, *K. Sv. Vet. Akad. Handl.*, 46(6): 77, 79.

1913. Holmgren, *K. Sv. Vet. Akad. Handl.*, 50(2): 81, 82.

1942. Hill, *Termites (Isoptera) Australian Region* : 176.

#### 2. Genus *Schedorhinotermes* Silvestri :

1949. Snyder, *Smiths. misc. Colls.*, 112: 89.

1950. Ahmad, *Bull. Amer. Mus. nat. Hist.*, 95(Art. 2):54, 56.

1955. Emerson, *Fieldiana : Zool.*, 37: 469, 479, 484, 500, 509.
1955. Weidner, In *Die Termiten* (Ed. Schmidt): 57.
1958. Ahmad, *Biologia*, Lahore, 4(1 & 2): 59, 60.
1961. Harris, *Termites : Recognition and Control* : 27, 48, 55. (2nd Ed. 1971).
1970. Krishna, In *Biology of Termites* (Eds. Krishna and Weesner) Vol. 2: 137, 139.
1970. Bouillon, In *Biology of Termites* (Eds. Krishna and Weesner) Vol. 2: 162.
1970. Roonwal, In *Biology of Termites* (Eds. Krishna and Weesner) Vol. 2: 341.
1970. Gay and Calaby, In *Biology of Termites* (Eds. Krishna and Weesner) Vol. 2: 406-407.
1970. Weidner, *Handb. d. Zoologie*, 4(2): 22.
1971. Emerson, *Bull. Am. Mus. nat. Hist.*, 146 (Art. 3); 248, 250, 251, 256.
1973. Chhotani and Bose, *Zool. Anz.*, 190(3/4): 233, 234.
1979. Roonwal, *Termite Life and Termite Control Trop. South Asia* : 4, 22, 80.
1982. Thapa, *Sabah For. Rec.*, No. 12: 5.
1983. Chhotani, *Orient. Insects*, 17: 111, 112, 113, 114, 119-120.
1985. Chhotani, *Z. ang. Ent.*, 100: 91, 93, 94.
1986. Grasse', *Termitologia* Vol. 3: 529.
3. Genus *Rhinotermes* Hagen :
1900. Sjöstedt, *K. Sv. Vet. Akad. Handl.*, 34(4): 19-21, 49.
4. Subgenus *Rhinotermes* (of *Termes*) Hagen :
1898. Haviland, *J. Linn. Soc. Lond.*, 26(169): 392.

Type of genus : *Rhinotermes intermedius* Brauer.

### 1. Characters of Genus *Schedorhinotermes*

*Imago* : Head subcircular. Fontanelle open, forwardly placed; with a groove leading to postclypeus. Eyes subcircular, prominently bulging, fairly large. Ocelli prominent, often large; separated from eyes. Antennae with 20 segments. Postclypeus more or less strongly swollen, projecting in front medially. Mandibles each with an apical and 3 marginal teeth. Left mandible with apical finger-like, 1st marginal equal to apical, 2nd smaller than 1st; 3rd almost as long as 1st but with a long anterior margin. Right mandible with apical as in left mandible; 1st marginal rudimentary, situated at anterior base of 2nd marginal; latter subequal to apical; 3rd small, with a long posterior margin subequal to molar plate. Pronotum flat; with anterior and posterior margins substraight. Legs with 3:2:2 apical tibial spurs; tarsi

4-jointed. Wings generally transparent, colourless, reticulate. Forewing scales larger than hindwing scales. Costa and radius thickly chitinous, dark. Media and cubitus thin. Media running medially with 3-4 branches. Cubitus with about 10-16 branches to posterior margin. All veins originating separately from scale except media in hindwing originating from radius outside scale. Wing microsculpturing comprises either only papillae or both papillae and pimples. Papillae present in single or many rows on either costa or on costa and radius, their size varies from  $3-9 \times 3-10.5 \mu\text{m}$  and density varies from 5717 - 9735/mm. Cerci 2-segmented, styli single-segmented.

**Soldier** : Dimorphic. Soldier major: Head large; fairly wide posteriorly and narrowed anteriorly. Fontanelle circular, open, forwardly situated; with a groove running upto tip of labrum. Eyes and ocelli absent. Antennae with 16-17 segments. Labrum ovate, reaching nearly to tip of mandibles; tip bifid, having a "daubing brush" or fringe of hairs. Mandibles large, sickle-shaped, strongly and sharply incurved apically. Left mandible with 2 marginal teeth and right with one marginal tooth. Postmentum club-shaped. Pronotum flat, narrower than head; projected in front medially and anteriorly slightly raised. Legs with 3:2:2 apical tibial spurs; tarsi 4-jointed. Cerci 2-segmented, styli single-jointed. Soldier minor: Head oval. Labrum long, narrow rectangular; generally extending upto or beyond mandibles, tip bifid and with daubing brush. Antennae with 15 segments. Postmentum comparatively broader and mandibles comparatively slender. Rest as in soldier major.

**Worker** : Head subsquarish. Eyes and ocelli absent. Antennae with 16-18 segments. Mandibles as in imago. Pronotum saddle-shaped. Legs as in soldier.

## 2. *Distribution and Composition of Schedorhinotermes*

**Distribution**(Fig. 217) : Genus *Schedorhinotermes* is known from the Oriental, the Australian, the Papuan and the Ethiopian, regions. From the Oriental Region it is reported from Malaysia (Sarawak, Sabah, Malacca, Malaya), Indonesia (Java, Sumatra, Macassar), Thailand, India, Bangladesh, Burma, the Philippines and South China. From India, it is recorded from the Andaman and Nicobar Islands. Chhotani (1983) has given the distribution of all the oriental species so far reported.

*Composition* : Fortythree species of genus *Schedorhinotermes* are known from the world. Of these 22 occur in the Oriental, 6 in the Australian, 8 in the Papuan and 7 in the Ethiopian regions (Chhotani 1985), of the 22 oriental species, 6 are reported from the Indian region, as follows :

1. *Schedorhinotermes eleanorae* Roonwal and Bose. India (Andamans).
2. *S. longirostris* Brauer. India (Kondul Island, Nicobars and Great Nicobar).
3. *S. medioobscurus* Holmgren. India (Middle and South Andamans), Malaysia (Malacca), Singapore and Thailand.
4. *S. sarawakensis* Holmgren. Burma, Malaysia, Indonesia and Thailand.
5. *S. tiwarii* Roonwal & Thakur. India (Andaman Islands).
6. *S. translucens* (Haviland). Malaysia, Indonesia, India, Bangladesh.

3. *Keys to Indian Region Species of Schedorhinotermes*

IMAGOES

Imagoes of only 4 species are known and are separated as follows:-

- |  |                      |
|--|----------------------|
| 1(2) Larger species : Head-width 2.10-2.17, pronotum-width 1.85-1.97 mm .....  | <i>sarawakensis</i>  |
| 2(1) Smaller species : Head-width 1.61-1.76, pronotum width 1.22-1.70 mm   |                      |
| 3(4) Eyes smaller (max. diameter 0.39-0.46 mm); ocelli smaller and farther away from eyes (long diameter 0.14-0.16, short diameter 0.10-0.13, eye-ocellus distance 0.06-0.10 mm) ..... | <i>medioobscurus</i> |
| 4(3) Eyes larger (max. diameter 0.50-0.54 mm); ocelli larger and closer to eyes (long diameter 0.17-0.18, short diameter 0.12-0.13, eye-ocellus distance 0.05-0.08 mm)                 |                      |
| 5(6) Third segment of antenna subequal to or slightly longer than second. Head in profile weakly swollen behind postclypeus. Pronotum substraight at anterior margin .....             | <i>eleanorae</i>     |
| 6(5) Third segment of antenna distinctly longer than second. Head in profile slightly depressed behind postclypeus. Pronotum weakly incurved at anterior margin .....                  | <i>translucens</i>   |

SOLDIERS MAJOR

- |  |                     |
|--|---------------------|
| 1(2) Larger species: Head-length to base of mandibles 2.20-2.49, head-width 2.28-2.54 mm ..... | <i>sarawakensis</i> |
|--|---------------------|

- 2(1) Smaller species: Head-length to base of mandibles 1.40-1.90, head width 1.33-1.85 mm
- 3(4) Head smaller and oval; head-length to base of mandibles 1.40-1.54, head-width 1.33-1.44 mm; mandibles shorter (0.80 mm) ..... *longirostris*
- 4(3) Head larger and subsquarish or oval; head-length to base of mandibles 1.45-1.90, head-width 1.40-1.85 mm; mandibles longer (0.85-1.12 mm)
- 5(6) Mandibles somewhat thinner and less so strongly hooked at tip; 3rd segment of antenna slightly longer than 2nd ..... *tiwarii*
- 6(5) Mandibles more robust and strongly hooked at tip; 3rd segment of antenna much longer than 2nd
- 7(8) Head in profile depressed behind antennae; postmentum more narrow at waist (minimum width at waist 0.23-0.27 mm) ..... *medioobscurus*
- 8(7) Head in profile not so depressed behind antennae; postmentum not so narrow at waist (minimum width at waist 0.28-0.33 mm) ..... *translucens*

### SOLDIERS MINOR

- 1(2) Large species: Head-length to base of mandibles 1.04-1.47; head-width 0.92-1.17, mandible-length 0.72-0.80 mm ..... *sarawakensis*
- 2(1) Smaller species: Head-length to base of mandibles 0.73-1.05, head-width 0.69-1.00, mandible-length 0.45-0.73 mm
- 3(6) Head oval; sides not sharply bulging out behind antennae
- 4(5) Small in size; head shorter. Tooth of left mandible forwardly placed. Antenna with 14 segments ..... *eleanorae*
- 5(4) Slightly larger in size; head longer and subrectangular. Tooth of left mandible somewhat backwardly placed. Antenna with 14-16 segments ..... *longirostris*
- 6(3) Head broadly oval, sides sharply bulging out behind antennae
- 7(8) Smaller and paler species (head-length to base of mandibles 0.75-0.88, head width 0.70-0.80 mm) ..... *medioobscurus*
- 8(7) Generally larger and darker (Head length 0.74-1.07, head-width 0.69-1.00 mm)
- 9(10) Mandibles straighter, thicker and less so incurved near tips. Postmentum strongly bulged. A very variable species ..... *translucens*
- 10(9) Mandibles less thick and more incurved at tips. Postmentum less so bulged ..... *tiwarii*

*Note* : The genus *Schedorhinotermes* is known by 6 species from the Indian Region. The imago caste is not known in case of 2 species, viz., *tiwarii* and *longirostris*, and soldier major in *eleanorae*. The soldier minor is found commonly and is known in all these 6 species. The soldiers (major and minor) of some of these species are very close to each other and it is very difficult to separate them, but the characters of soldier major or minor combined with those of imagoes can, however, help to distinguish them. For example, the imago of *medioobscurus* can be differentiated from that of *translucens* and *eleanorae* for its smaller eyes, while the soldier major of *medioobscurus* and *translucens* are very close and not easily differentiated, except on some minor characters. Similarly the soldiers minor of some species show so much variation in size and overlapping of characters that they can hardly be differentiated, except again on minor characters. As such the non-availability of all the castes in a particular species may cause problems in correct identification.

## 82. *Schedorhinotermes eleanorae* Roonwal and Bose (Figs. 270, 271)

*Schedorhinotermes eleanorae* Roonwal and Bose:

1970. Roonwal and Bose, *Rec. zool. Surv. India*, 62 (3&4): 119, 125-132. Im, S minor, W. Holotype : *S minor* in ZSI, Calcutta. Type-locality : Bedeabdulu, 19 km South of Tokoibuea, Little Andaman Is. Types examined.

1980. Bose, *Rec. zool. Surv. India*, 77 : 100.

1983. Chhotani, *Oriental Insects*, 17 : 120

**IMAGO DEALATE (Fig. 270) :** Head-capsule, mandibles, pronotum and wing scales golden brown; thorax and abdomen paler; fontanelle and anteclypeus whitish; postclypeus and labrum yellowish and antennae and legs somewhat paler. Head sparsely and body more densely pilose. Total length without wings 6.8-7.0 mm. Head-capsule subrounded, broader than long (length 1.38-1.40, width with eyes 1.75 mm). Fontanelle distinct, rounded, situated in middle of anterior part of head at level of ocelli. Eyes large, bulging, subrounded (maximum diameter 0.50-0.53, minimum diameter 0.48 mm). Ocelli small, suboval (maximum diameter 0.18 mm); separated from eyes by less than short diameter (minimum eye - ocellus

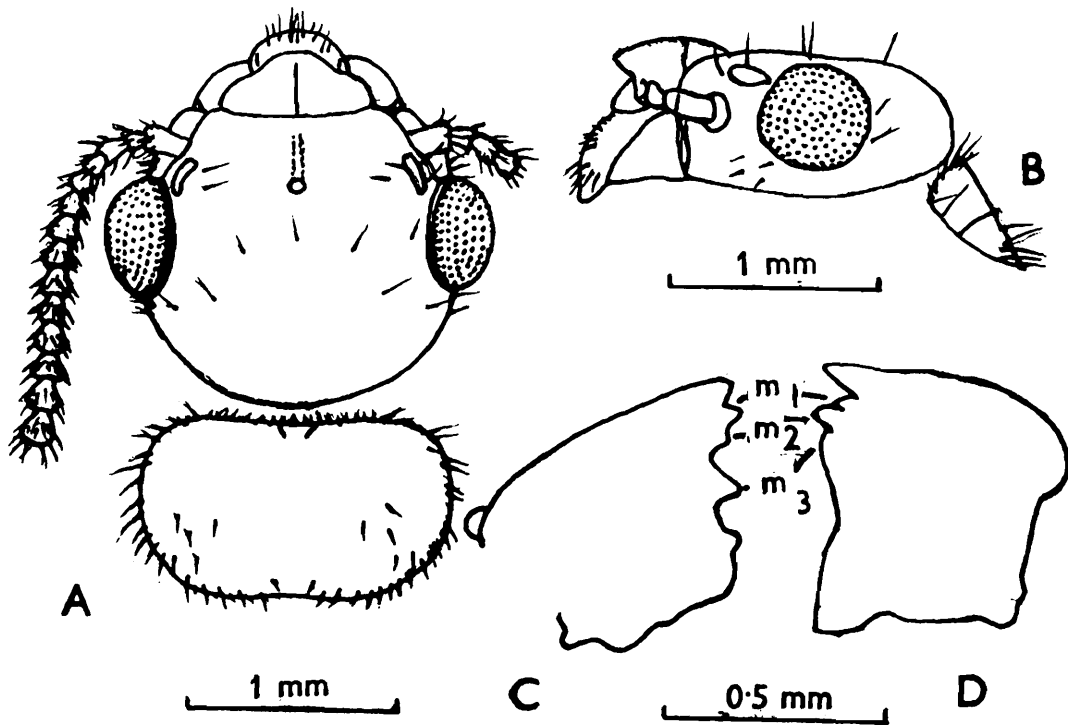

Fig. 270. *Scheaorhinotermes eleanorae*. Imago. (A) Head and pronotum, dorsal view. (B) Same, side view. (C) and (D) Left and right mandibles, respectively. (Redrawn from Roonwal and Bose, 1970.)

m<sub>1</sub>-m<sub>3</sub>, 1st to 3rd marginal teeth.

distance 0.05-0.08 mm). Antennae with 14 + segments; segment 2 subequal to 3, 4 shortest; from 5 gradually increasing in size. Postclypeus large, sparsely pilose, distinctly demarcated from frons; projected in front medially. Anteclypeus narrow, apilose; with a broadly pointed tip. Labrum broader than long (length 0.37, width 0.53 mm); with anterior margin rounded and with a few hairs on body. Mandibles as in genus. Pronotum flat, sparsely pilose, subtrapezoidal; much broader than long (width 1.48-1.55, length 0.85-0.90 mm); narrower than head-width with eyes; sides rounded; anterior margin substraight, posterior margin weakly notched in middle. Legs long, tibial spurs 3:2:2; tarsi 4-jointed. Abdomen oblong; cerci 2-segmented, styli one-segmented.

**SOLDIER MAJOR** : Unknown.

**SOLDIER MINOR** (Fig. 271) : Head capsule, labrum and antennae pale yellow; mandibles deep yellowish brown; legs and abdomen pale

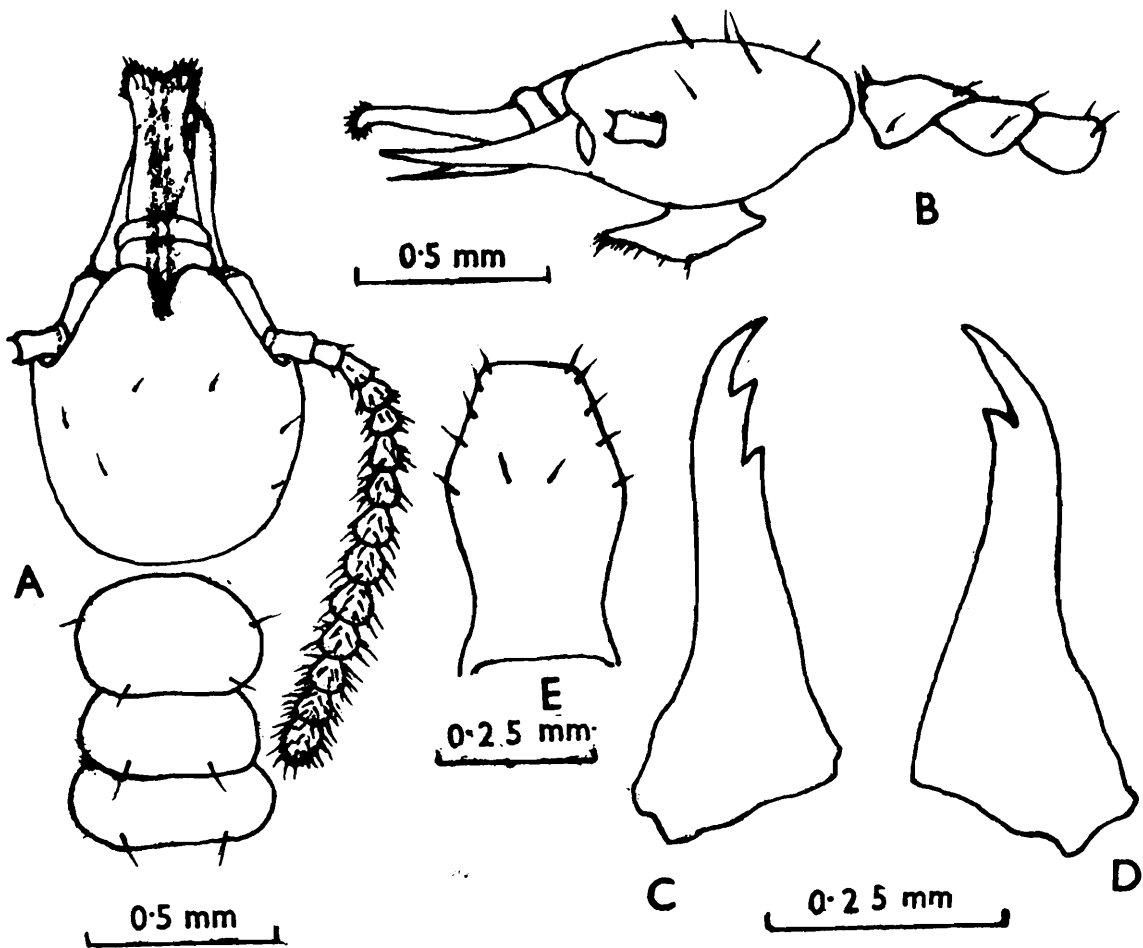

Fig. 271. *Schedorhinotermes eleanorae*. Soldier minor. (A) Head and thorax, dorsal view. (B) Same, side view. (C) and (D) Left and right mandibles, respectively. (E) Postmentum. (Redrawn from Roonwal and Bose 1970.)

yellowish white. Head and thorax sparsely and body fairly, pilose. Total length 2.95-3.30 mm. Head-capsule, subpentagonally oval, posteriorly rounded; a little longer than broad (length to mandible-base 0.73-0.79, width 0.68-0.70 mm); widest in anterior region. Fontanelle distinct, rounded, lying in anterior one-fourth of head; with a groove running from it to tip of labrum. Antennae with 14 segments; segments 2 and 3 small subequal; 4 shortest; 5 onwards gradually increasing in size to club-shaped apical segment. Postclypeus pilose, indistinctly demarcated from frons; anteclypeus narrow, apilose. Labrum subrectangular, flap-like, with distal end bilobed and fringed with short hairs; much longer than broad, length (0.38-0.43, width 0.15-0.20 mm) extending beyond mandibles. Mandibles long (0.45-0.50 mm), slender, basally broad and with apices incurved and

pointed. Left mandible with 2 sharp teeth in distal one-third and right with one sharp tooth very close to apex. Postmentum sparsely pilose; longer than broad (length 0.38-0.40, maximum width 0.28 mm); broadest in anterior part from whence sides converging to a substraight anterior margin and posteriorly to a broad waist (width at waist 0.18-0.20 mm), and then again widening out to a subconcave posterior margin. Pronotum very sparsely pilose, flat and rhomboidal; broader than long (width 0.43-0.48, length 0.30 mm); anterior margin convexly rounded; posterior margin with a weak median notch. Legs long, tibial spurs 3:2:2; tarsi 4-jointed. Abdomen oblong; cerci 2-segmented; styli minute, one-segmented.

**WORKER** : Generally pale yellow in colour. Head, thorax and body fairly pilose. Total length 3.90-4.40 mm. Head-capsule subsquarish (length to base of mandibles 0.98-1.05, width 1.13-1.18 mm). Fontanelle indistinct. Eyes and ocelli absent. Antennae 15-segmented, segment 2 longer than 3 or 4; the latter two subequal, smallest. Postclypeus fairly large, distinctly separated from frons by a clear suture; anteclypeus narrow, apilose. Labrum subsquarish, broader than long and with distal end rounded. Mandibles as in imago. Pronotum saddle-shaped; much broader than long (width 0.55-0.58, length 0.23-0.25 mm); both anterior and posterior margins with weak, median notch. Legs and abdomen as in soldier minor.

*Distribution* : INDIA : Andaman and Nicobar Islands : Bedeabdulu (Little Andaman Is.) and Neil Island Reserve Forest (South Andamans).

### 83. *Schedorhinotermes longirostris* (Brauer)

(Figs. 272, 273)

1. *Termes* sp. :

1865. Brauer, *Verh. zool. bot. Ges. Wien*, 15: 977.

2. *Termes longirostris* Brauer :

1866. Brauer, *Reise der Fregatte Novara* (Zool. Theil), 2 (Abth. 1, Art. 4) : 47-48. S minor and major, W, Ny. Lectotype (selected Roonwal and Bose 1970) : S major, in Naturhistorisches Mus., Vienna.

3. *Rhinotermes* (*Schedorhinotermes*) *longirostris* (Brauer) :

1911. Holmgren K. *Sv. Vet. Akad Handl.*, 46(6): 79.

1913. Holmgren, K. *Sv. Vet. Akad Handl.*, 50(2): 82, 86.

1913-14. Holmgren *Zool. Jahrb. (Syst.)*, 36: 240.

1921. Light, *Philipp. J. Sci.*, 18(3): 250.

1925. John, *Treubia*, 6(3 & 4) : 384.

4. *Schedorhinotermes longirostris* (Brauer) :

1949. Snyder, *Smiths. misc.Colls.*, 112: 93.

1953. Roonwal and Pant, *Indian Forest Leaflet*, No. 121(3): 49.

1958. Ahmad, *Biologia*, Lahore, 4(1-2): 81.

1963. Roonwal and Thakur, *Indian J. agric. Sci.*, 33(2): 116, 117.

1970. Roonwal and Bose, *Rec. zool. Surv. India*, 62 (3 & 4): 132-138.

1980. Bose, *Rec. zool. Surv. India*, 77: 100.

1983. Chhotani, *Orient. Insects*, 17: 120.

IMAGO : Unknown.

**SOLDIER MAJOR (Fig. 272) :** Head-capsule yellowish; labrum, antennae, legs and body paler; mandibles reddish brown, basally yellowish. Head and body sparsely pilose with long bristle-like hairs; abdominal tergites with a

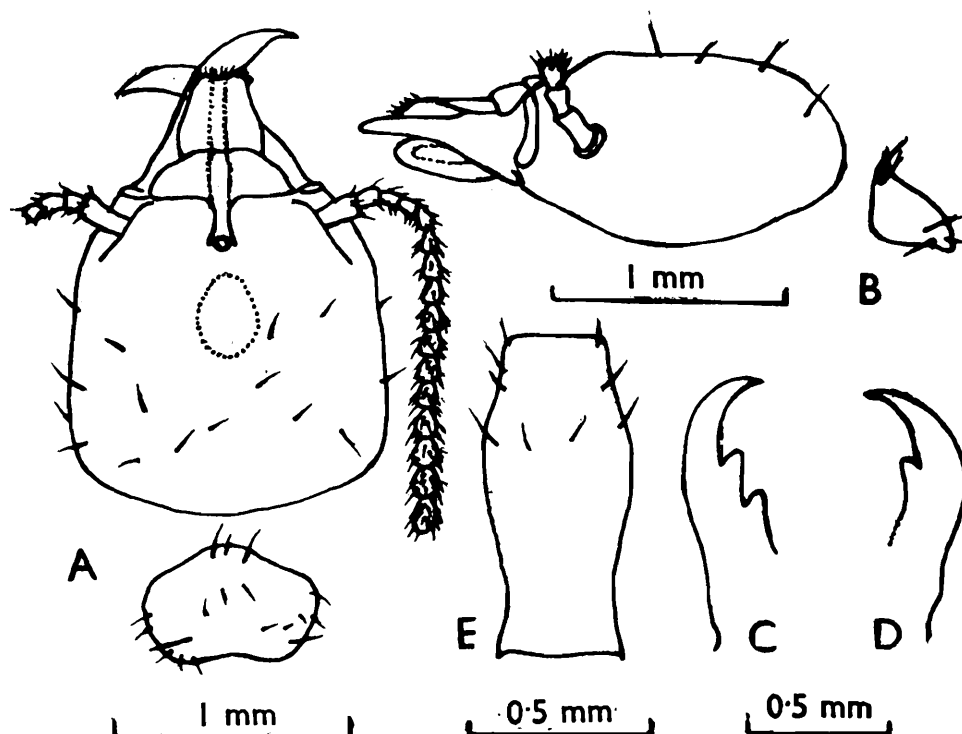

Fig. 272. *Schedorhinotermes longirostris*. Soldier major. (A) Head and pronotum, dorsal view. (B) Same, side view. (C) and (D) Left and right mandibles. (E) Postmentum. (Redrawn from Roonwal and Bose 1970)

row of long hairs near posterior margin and few short ones elsewhere. Total length c 4.8-5.0 mm. Head capsule subquadrate longer than broad (length to base of mandibles 1.40, width 1.33 mm); with posterior angles and margin rounded; sides narrowing gradually upto level of antennae, and abruptly converging towards anterior end at mandible base. Fontanelle small, round, situated medially at level of antennal sockets; leading behind into fontanelle gland and in front into a groove on head-surface running upto almost the front margin of labrum. Eyes and ocelli absent. Antennae with 16 segments, segment 2 shorter than 3; 4 shortest. Postclypeus not well separated from anteclypeus, the two together subtrapezoidal and with a weak median notch in anterior margin. Labrum broadly tongue-shaped, width and length equal (0.37 mm); reaching upto two thirds of length of mandibles and fringed with short hairs at anterior margin. Mandibles robust and thick (0.80 mm long), sickle-shaped and with strongly pointed incurved apices. Left mandible with two prominent teeth in anterior half; right with only one tooth well above middle. Postmentum with a few hairs at anterior end; broadly club-shaped, 0.90 mm long; broadest at anterior one-third (maximum width 0.40 mm) and narrowing to a waist lying below middle (waist width 0.27 mm). Pronotum, broader than long (length 0.50, width 0.70 mm); anterior margin weakly raised, and projected forward medially; sides rounded and converging to a medially incurved posterior margin. Legs thin, long, tibial spurs 3:2:2, tarsi 4-jointed. Abdomen oblong; cerci 2-segmented; styli small, one-segmented.

**SOLDIER MINOR ( Fig. 273):** Head-capsule and labrum yellowish; antennae, legs, proximal part of mandibles and body pale yellow, mandibles distally pale brown. Head and thorax sparsely hairy. Abdomen fairly hairy with long bristle-like hairs, arranged in a row on posterior margin of each tergite. Total length 3.3-3.8 mm. Head-capsule oval, longer than broad (length to base of mandibles 0.80, width 0.71-0.73 mm); sides weakly convex, converging anteriorly from base of antennae; posterior margin rounded. Fontanelle, circular situated behind clypeus; fairly prominent (0.03-0.04 mm in diameter); leading backwards into a fontanelle gland; a median, dorsal groove runs from fontanelle to tip of labrum. Eyes and ocelli absent. Antennae with 15-16 segments, segment 3 in 15-segmented and 4 in 16-segmented antennae, shortest. Postclypeus and anteclypeus weakly separated, trapezoidal, anterior margin rounded. Labrum long, subrec-

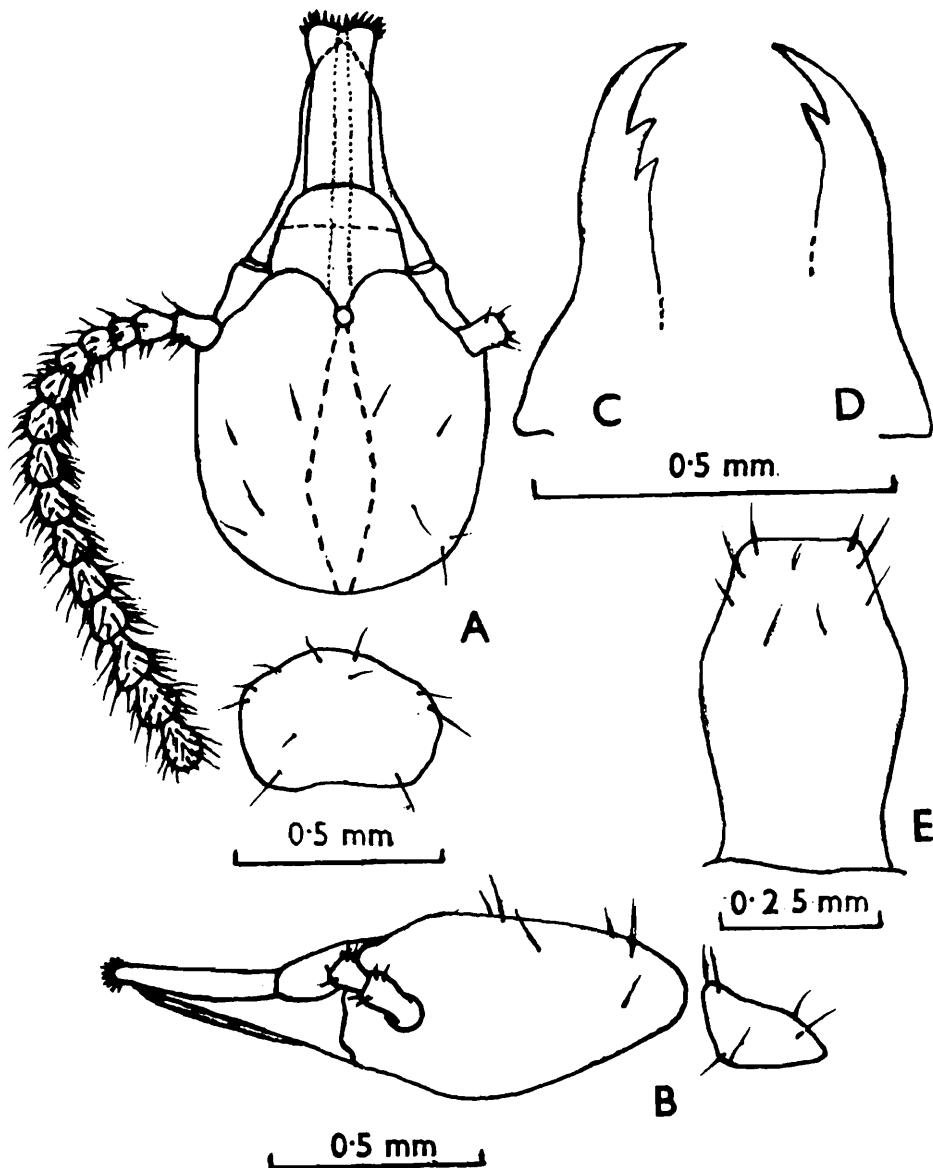

Fig. 273. *Schedorhinotermes longirostris*. Soldier minor. (A) Head and pronotum, dorsal view. (B) Same, side view. (C) and (D) Left and right mandibles. (E) Postmentum. (Redrawn from Roonwal and Bose 1970).

tangular, flap-like, extending beyond tip of mandibles; much longer than broad (length 0.37-0.40, width 0.17-0.20 mm); anterior margin weakly bifid and fringed with numerous short hairs (daubing brush). Mandibles long (0.51-0.53 mm), sabre-shaped, slender, weakly incurved distally; left mandible with 2 sharp teeth directed forward in apical one-third and right with a single tooth near apex. Postmentum strongly arched, swollen; longer

than broad, broadest in anterior one-third, narrowing behind to a broad waist (length 0.47-0.50, max. width 0.30, width at waist 0.23-0.25 mm); anterior margin substraight. Pronotum flat, broader than long (length 0.30-0.33, width 0.43-0.47 mm); anterior margin projecting a little medially and with no notch; posterior margin substraight or with a weak median incurving. Legs and abdomen as in soldier major; legs however thinner.

**WORKER** : Head yellowish, body paler. Head-capsule, subsquarish, broader than long (width 1.20-1.30, length to base of mandibles 1.03-1.07 mm). Fontanelle indistinct. Eyes and ocelli absent. Antennae with 16-segments, segment 4 shortest. Postclypeus pilose, clearly separated from frons; anteclypeus narrow, apilose. Labrum broadly tongue-shaped; much broader than long, with a few hairs. Mandibles of *Schedorhinotermes*-type. Pronotum saddle-shaped; much broader than long (width 0.50-0.57, length 0.17-0.23 mm); anterior and posterior margins without notch. Legs and abdomen as in soldier minor.

*Distribution* : INDIA : Andaman and Nicobar Islands; Kondul Is. (Nicobars, type-locality) and Great Nicobar. Other records in literature really refer to other species according to Roonwal and Bose 1970.

#### 84. *Schedorhinotermes medioobscurus* Holmgren (Figs. 274-276)

1. *Rhinotermes (Schedorhinotermes) brevialetus* f. *medioobscurus* Holmgren :

1914. Holmgren, *Zool. Jahrb. (Syst.)* 36: 241. Im, S, W. Syntypes : Probably in Holmgren collection at National Museum, Stockholm. Type-locality: Trong in Taiping, Malacca, Malaysia.

2. *Rhinotermes (Schedorhinotermes) longirostris* (Brauer). Wrong determinations :

1913. Holmgren, *K. Sv. Vet. Akad. Handl.*, 50(2): 86. Specimens from Malacca only are *medioobscurus*.

1953. Roonwal and Pant, *Indian For. leafl. (Ent.)*, No. 121(3): 49.

3. *Schedorhinotermes medioobscurus* Holmgren :

1949. Snyder, *Smiths. misc. Colls.*, 112: 94.

1958. Ahmad, *Biologia*, Lahore, 4(1 & 2): 79, 81, 83.

1963. Roonwal and Thakur, *Indian J. agric. Sci.*, 33(2): 116, 117.

1965. Ahmad, *Bull. Am. Mus. nat. Hist.* 131(Art. 1.): 24-27, 28, 29.

1970. Roonwal and Bose, *Rec. zool. Surv. India*, 62(3 & 4): 119, 138-140.

1973. Morimoto, *Bull. Gov. For. exp. Stn.*, No. 257 : 61, 77.

1970. Bose, *Rec. zool. Surv. India*, 77 : 100.

1982. Thapa, *Sabah, For. Rec.*, No. 12 : 129-135.

1983. Chhotani, *Orient. Insects*, 17 : 120.

**IMAGO (Fig. 274):** Head reddish yellow, somewhat paler posteriorly; postclypeus pale reddish yellow with a brown median line; labrum and antennae light brownish yellow; pronotum yellow with reddish tinge at anterior and posterior margins; wings light smoky brown basally, rest hyaline. Head with a few, scattered, erect bristles; pronotum with long bristles along margins, a few on disc; wing scales with long, posteriorly directed, suberect bristles. Total length with wings 10.5-11.0, without wings 6.5 mm. Head subcircular (length to base of mandibles 1.09-1.21, width with eyes 1.61-1.71 mm). Fontanelle small, circular; situated medially at level of posterior ends of ocelli. Eyes large, circular, bulging (long diameter 0.39-0.46, short diameter 0.33-0.39 mm): separated from lower margin of

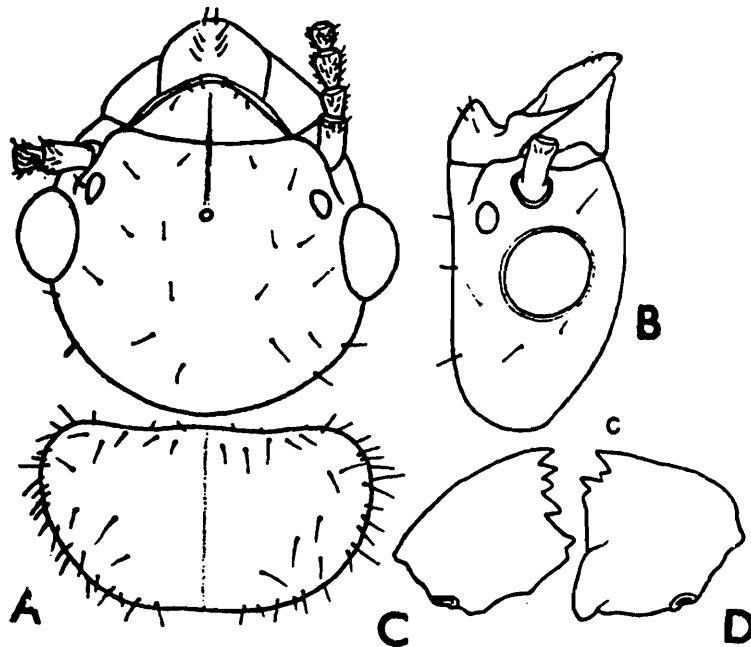

Fig. 274. *Schedorhinotermes medioobscurus*. Imago. (A) Head and pronotum, dorsal view. (B) Head, side view. (C) and (D) Left and right mandibles. (After Ahmad 1965.)

head by one-fourth of their diameter (0.07-0.11 mm). Ocelli broadly oval (length 0.14-0.16, width 0.10-0.13 mm); separated from eyes by slightly less than their short diameter (0.06-0.10 mm). Postclypeus somewhat conical with broad base and rounded tip; in profile swollen and overhanging anteclypeus. Labrum broadly dome-shaped. Mandibles as in genus. Antennae with 20 segments; segment 3 one-and-a-half times as long as 2. Pronotum much broader than long (width 1.22-1.40, length 0.78-0.83 mm); anterior margin slightly convex in middle, not emarginate; sides broadly rounded; posterior margin almost straight.

**SOLDIER MAJOR (Fig. 275):** Head reddish yellow; postclypeus basally and antennal carinae reddish brown; anteclypeus whitish; labrum paler than head; mandibles reddish brown, reddish yellow at base; antennae pale brownish; pronotum yellow, pale brownish near margins; legs yellowish. Head very sparsely hairy; pronotum with only a few long and short bristles along margins and abdominal tergites with a posterior row of long and short bristles. Head subsquarish; length to base of mandibles 1.45-1.83, maximum width 1.40-1.61 mm; lateral margins slightly narrowed anterior to antennal carinae, otherwise substraight or faintly convex; posterior margin rounded. Fontanelle circular; with a groove running in front upto postclypeus base. Anteclypeus short, membranous, trapezoid; postclypeus slightly darker than head and wider than long. Labrum almost as broad as long, broadest in middle (length 0.43-0.47, width 0.42-0.45 mm); tip hyaline, weakly bilobed, with a fringe of short hairs at anterior margin. Antennae with 16-17 segments; segment 2 longer than 3 and 4 in 17 segmented ones, in 16-segmented ones 3 longer than 2. Mandibles robust, sickle-shaped; strongly curved at tips (length 0.85-1.07 mm); left mandible with two marginal teeth and right with one. Postmentum long (length 1.00-1.12), moderately arched; broadly club-shaped; widest in anterior half (maximum width 0.41-0.46 mm) from whence narrowing down to a waist near posterior margin (width at waist 0.23-0.27 mm). Pronotum much broader than long (width 0.83-1.00, length 0.55-0.60 mm); anterior margin produced in middle; posterior margin slightly depressed in middle. Legs long, apical tibial spurs 3:2:2.

**SOLDIER MINOR (Fig. 276):** Head pale yellow; antennal carinae and posterior part of postclypeus reddish brown; labrum slightly darker than head and with a hyaline tip; mandibles pale reddish brown, paler basally;

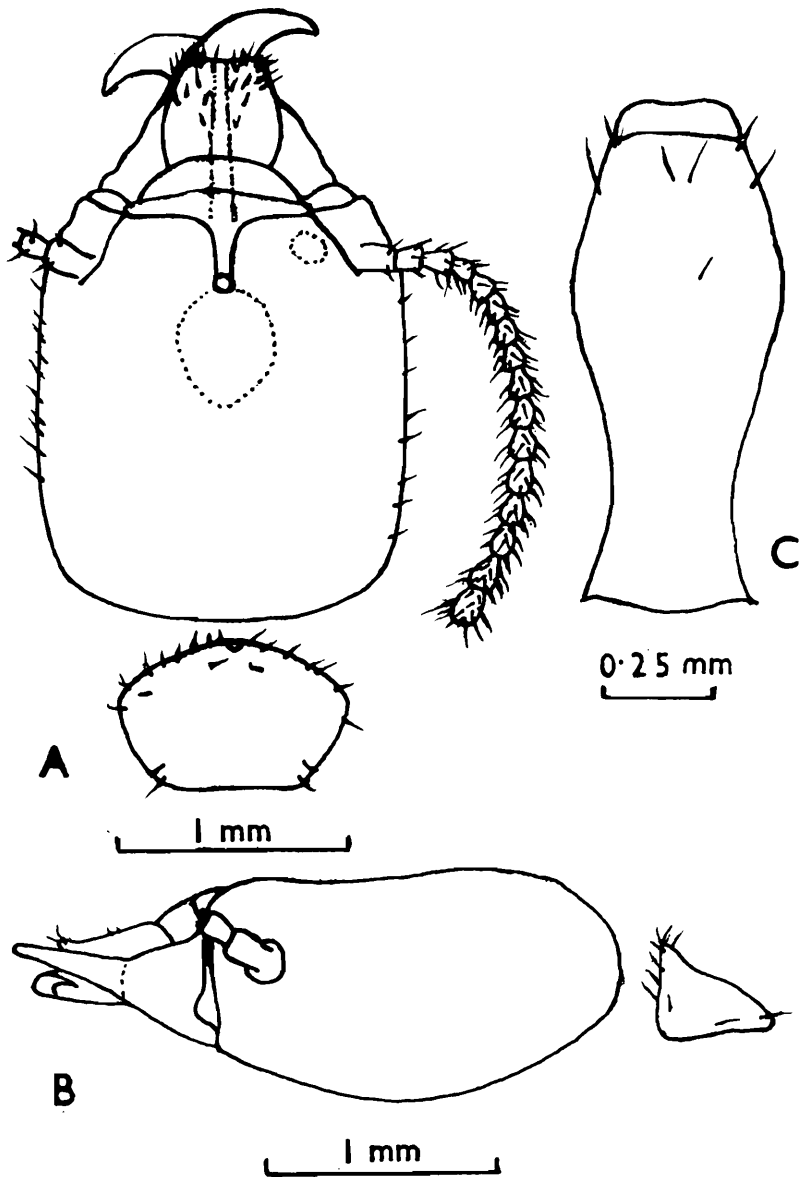

Fig. 275. *Schedorhinotermes medioobscurus*. Soldier major. (A) Head and pronotum, dorsal view. (B) Same, side view. (C) Postmentum. (Redrawn from Roonwal and Bose 1970.)

pronotum pale brownish; abdomen dirty yellow. Head and body with a few long hairs. Total length 3.5-4.3 mm. Head subsquarish, narrowed in front of antennae; sides substraight or slightly convex; head-length to base of mandibles 0.75-0.88, maximum head-width 0.70-0.80 mm. Fontanelle circular, placed anterior to base of antennae; with a groove running from it to tip of labrum. Eyes and ocelli absent. Antennae with 15-16 segments; in

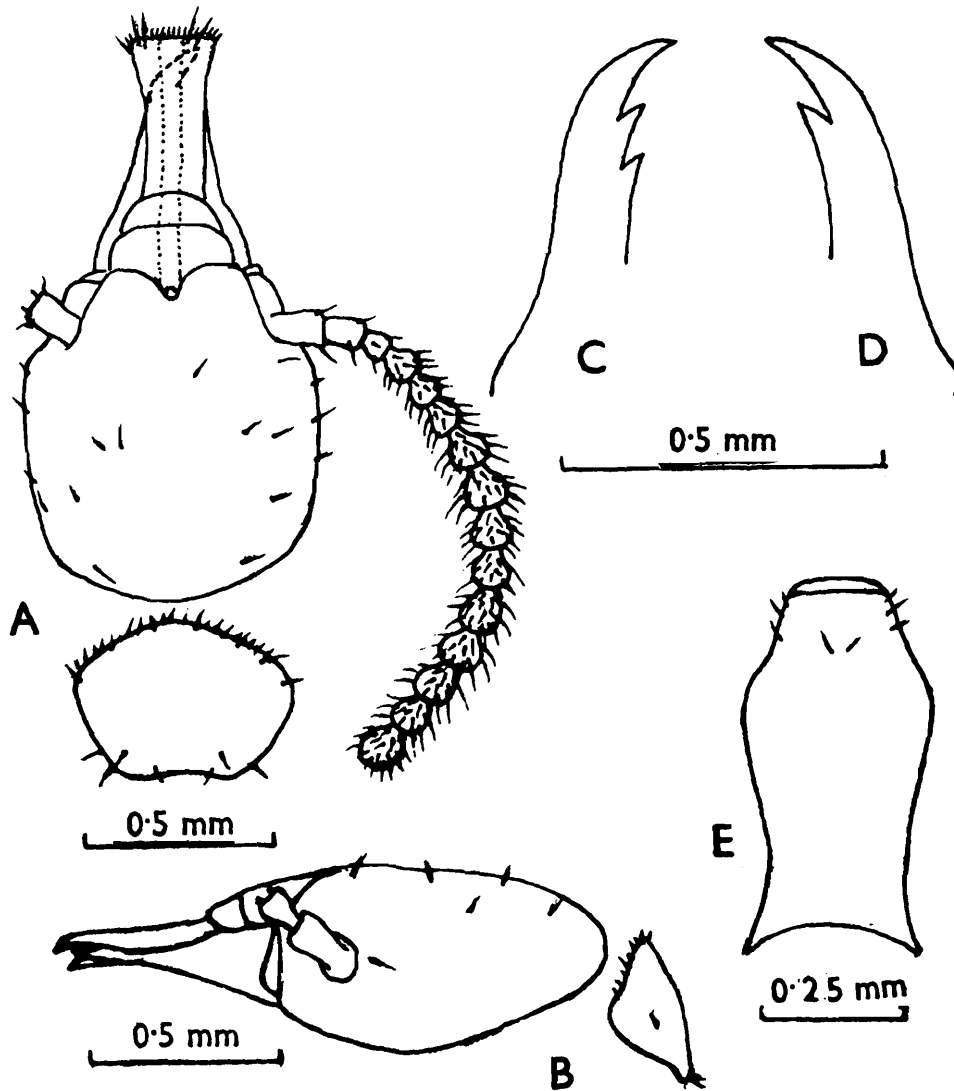

Fig. 276. *Schedorhinotermes medioobscurus*. Soldier minor. (A) Head and pronotum, dorsal view. (B) Same, side view. (C) and (D) Left and right mandibles. (E) Postmentum. (Redrawn from Roonwal and Bose 1970.)

15-segmented one 2 longer than 3, 4 slightly longer than 3, 3 and 5 subequal. Postclypeus subtrapezoidal, broader than long. Anteclypeus narrow, hyaline; anteriorly convex. Labrum elongate, subrectangular; tip bilobed, with a fringe of hairs (the daubing brush). Mandibles thin, delicate, sabre-shaped; left with 2 and right with one marginal teeth placed anteriorly. Postmentum as in soldier major, but somewhat more arched and wider at waist in comparison to maximum width; length 0.52-0.54, maximum width 0.27-0.29, minimum width 0.23-0.24 mm. Pronotum as in soldier major,

but longer comparative to width (length 0.35-0.40, width 0.50-0.58 mm). Legs as in soldier major.

**WORKER:** Head pale yellow; body straw yellow. Head and body moderately hairy. Total length (c 3.50-5.00 mm). Head nearly subsquarish, wider than length to base of mandibles; head-length to base of mandibles 1.13-1.2, head-width 1.25-1.35 mm. Fontanelle indistinct. Antennae with 16 segments; 4th segment shortest. Postclypeus swollen, short. Labrum and mandibles as in genus. Pronotum saddle-shaped; length 0.25-0.30, width 0.75-0.85 mm; anterior lobe without emargination. Legs as in soldier.

*Distribution* : INDIA: Middle and South Andamans. MALAYSIA: Trong, in Taiping, Malacca (type-locality); Kuala Lumpur. SINGAPORE and THAILAND.

**85. Schedorhinotermes sarawakensis Holmgren**  
(Syn. *S. magnificus* Silvestri)  
(Figs. 277-279)

1. *Rhinotermes (Schedorhinotermes) sarawakensis* Holmgren:

1913. Holmgren, *K. Sv. Vet. Akad. Handl.*, 50(2) : 87-88. S major, S minor, W. Holotype: Not designated. Syntypes probably in Holmgren Collection, National Museum, Stockholm. Type-locality: Sarawak, Borneo, Malaysia.

1913-14. Holmgren, *Zool. Jb. (Syst.)*, 36: 242.

1925. John, *Treubia*, 6(3&4): 384.

2. *Schedorhinotermes sarawakensis* Holmgren:

1949. Snyder, *Smiths. misc. Colls.*, 112 : 95.

1958. Ahmad, *Biologia*, Lahore, 4(1-2): 79-80, 81.

1965. Ahmad, *Bull. Am. Mus. nat. Hist.*, 131(Art.1): 24, 29-30.

1982. Thapa, *Sabah For. Rec.*, No. 12 : 115, 116, 135-142.

1983. Chhotani, *Orient. Insects*, 17 : 20.

3. *Schedorhinotermes magnificus* Silvestri:

1914. Silvestri, *Rec. Indian Mus.*, 8(5): 425-426. S. major, S. minor, W. Syntypes : S major and W, in ZSI. Type-locality : Dawna Hills, Lower Burma.

1949. Snyder, *Smiths. Misc. Colls.*, 112 : 95.

**IMAGO** (Fig. 277): Head and abdomen reddish yellow; pronotum and wing scales paler; anteclypeus whitish; labrum, postclypeus, antennae and

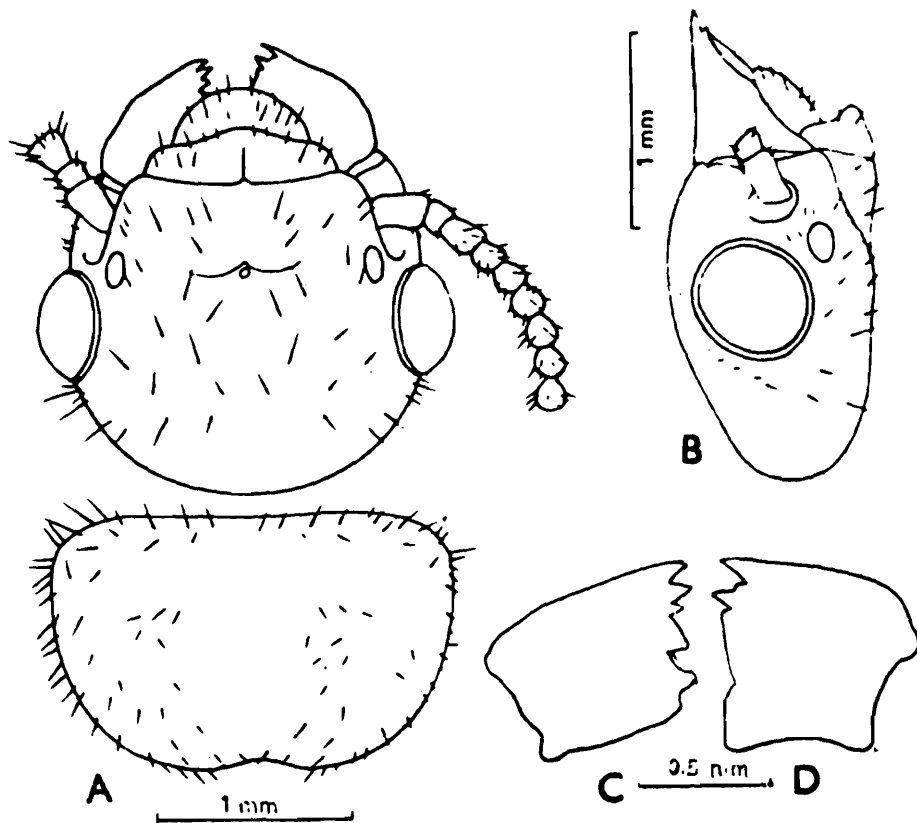

Fig. 277. *Schedorhinotermes sarawakensis*. Imago. (A) Head and pronotum, dorsal view. (B) Head, side view. (C) and (D) Left and right mandibles. (After Thapa 1982.)

legs brownish yellow. Head and body fairly and wing scales, legs and abdomen densely pilose. Head-capsule broader than long, length of head to base of mandibles 1.65-1.80, width (with eyes) 2.10-2.17 mm; sides rounded, anteriorly slightly converging; posterior margin rounded; Y-suture indistinct. Fontanelle small, situated a little below antennae. Eyes large, circular, maximum diameter 0.60-0.63, minimum diameter 0.53-0.57 mm; separated from lower margin of head by less than one-fourth of their maximum diameter, distance of eye from lower margin of head 0.15-0.20 mm. Ocelli broadly oval, length of ocellus 0.15-0.17 mm, width of ocellus 0.12-0.15 mm; separated from eyes by about half their maximum length (eye-ocellus distance 0.07-0.11 mm). Antennae with 20 segments; segment 3 more than one-and-a-half times as long as 2; segment 4 subequal to 2. Anteclypeus trapezoid. Postclypeus produced anteriorly, overhanging anteclypeus; a median line dividing it into right and left lobes. Labrum

dome-shaped, anterior margin substraight. Mandibles as in genus. Pronotum slightly narrower than head, broader than long (width 1.85-1.97, length 1.20-1.35 mm); sides convexical; anterior margin substraight; posterior margin medially emarginate. Forewing: Costa bordering anterior margin; radius running close to and parallel with costal border; several cross veins between costal border and radius at distal end; media unsclerotized, running midway between radius and cubitus, in proximal half with 3-4 branches; cubitus running in middle of wing with 14-16 branches. Hindwing: Costa and radius as in forewing; media unsclerotized, arising from radius just outside wing suture, with 3-4 branches; cubitus running in middle of wing, with 14-16 branches. Legs long, apical tibial spurs 3:2:2.

**SOLDIER MAJOR (Fig. 278):** Head-capsule reddish to brownish yellow; labrum pale yellowish brown, anteriorly hyaline; antennae pale brownish;

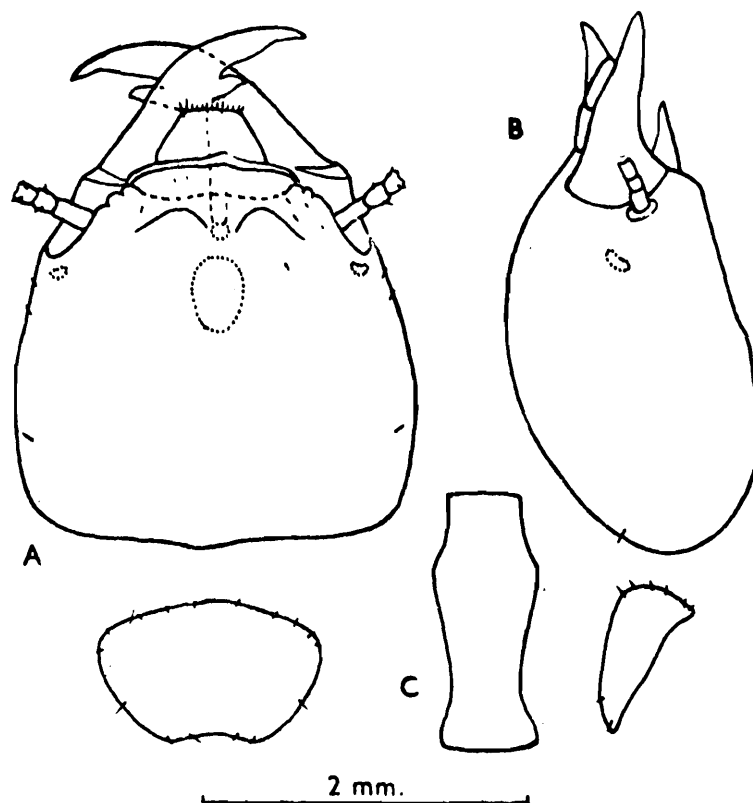

Fig. 278. *Schedorhinotermes sarawakensis*. Soldier major. (A) Head and pronotum, dorsal view. (B) Same, side view. (C) Postmentum. (Drawings from syntype of *S. magnificus* Silvestri, a synonym of *S. sarawakensis*.)

mandibles reddish brown, paler basally; pronotum, legs and abdominal tergites yellowish brown, paler than head. Head sparsely and body fairly pilose; labrum with a fringe of short hairs on anterior margin. Total length 6.50-7.50 mm. Head-capsule broadly oval, a little broader than long (length to base of mandibles 2.20-2.40, width 2.28-2.54 mm); broadest near posterior margin; sides narrowed in front; posterior margin convex, slightly projected in middle, with a low concavity on either side giving it a wavy look. Fontanelle circular, fairly large, situated medially in between antennal carinae; with a groove running from fontanelle to tip of labrum. Antennae with 17-18 segments; segment 3 long, club-shaped, longer than 2, in 17-segmented one. Eyes and ocelli absent. Anteclypeus very thin, narrow and hyaline. Postclypeus subrectangular, flat, much broader than long. Labrum broad, tongue-shaped; length 0.50-0.56, width 0.60-0.67 mm; with a median groove; widest at posterior third; lateral margins and apex hyaline; apex weakly bilobed and with a fringe of hairs at anterior margin. Mandibles thick and robust, sickle-shaped (length 1.38-1.40 mm); strongly incurved anteriorly; marginal teeth prominent; left mandible with two and right with one marginal teeth. Postmentum club-shaped, weakly arched; length 1.45-1.68, maximum width 0.57-0.75 and minimum or waist width 0.30-0.35 mm; waist lying near posterior margin. Pronotum flat, broader than long; width 1.40, length 0.80 mm; anterior margin projected in front and weakly notched; sides rounded, narrowed posteriorly to a convex medially incurved posterior margin. Mesonotum almost as wide as pronotum, posterior margin less so incurved than pronotum; metanotum almost as wide as pronotum but without incurving at posterior margin. Legs stout, long, thick; apical tibial spurs 3:2:2; tarsi 4-jointed. Abdomen oblong; cerci 2-segmented; styli when present one-segmented.

**SOLDIER MINOR (Fig. 279):** Head-capsule and body yellowish; labrum and antennae pale brownish yellow; anteclypeus whitish; mandibles light reddish brown, basally paler; pronotum pale yellowish; legs and abdominal tergites yellowish. Head and body sparsely pilose; labrum with a fringe of hairs at anterior margin forming the 'daubing brush'. Total length 4.5-5.0 mm. Head-capsule oval, much longer than wide; head-length to base of mandibles 1.04-1.47, head-width 0.92-1.17 mm; sides converging anterior to antennae and widest behind middle. Fontanelle small, circular, situated

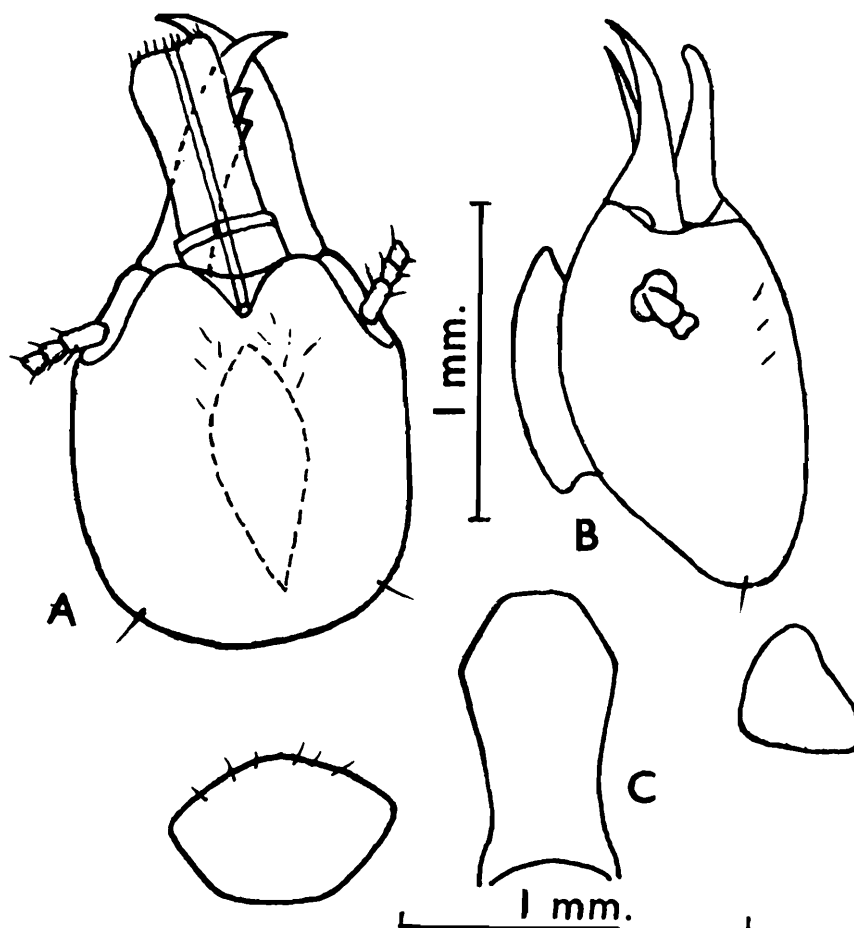

Fig. 279. *Schedorhinotermes sarawakensis*. Soldier minor. (A) Head and thorax, dorsal view. (B) Same, side view. (C) Postmentum. (Drawings from syntype of *S. magnificus* Silvestri, a synonym of *S. sarawakensis*.)

medially in front of antennal carinae; with a groove running upto tip of labrum. Eyes and ocelli absent. Antennae with 16-segments; segment 3 variable. Labrum subrectangular, bifid at anterior margin; reaching almost upto tip of mandibles. Mandibles as in other species but larger (0.72-0.80 mm). Postmentum club-shaped; comparative to maximum width wider at waist than in soldier major; length 0.72-0.80, maximum width 0.33-0.39, minimum or waist width 0.23-0.31 mm. Pronotum flat, broader than long; anterior margin projected in front in middle; length 0.46-0.56, width 0.72-0.86 mm. Legs and abdomen as in soldier major, but smaller.

**WORKER:** Head pale yellow; antennae, labrum, pronotum and body paler; abdomen dirty white. Head and body fairly densely pilose. Total length 5.0-6.0 mm. Head-capsule subsquarish, broader than long (length to base of mandibles 1.40, width 1.75 mm); sides convex. Fontanelle indistinct. Eyes and ocelli absent. Antennae 17-18 segmented; segment 4 shortest. Postclypeus swollen, incompletely divided by a median suture; broader than long, length less than half its width; with a few hairs on anterior margin and on body; anteclypeus very thin, hyaline. Labrum dome-shaped, broader than long, length 0.40-0.50, width 0.60-0.63 mm. Mandibles as in genus. Pronotum saddle-shaped, broader than long (width 0.95-1.00, length 0.48-0.50 mm); anterior margin without emargination; posterior margin weakly incurved. Legs as in soldier but slightly shorter.

*Distribution:* BURMA: Dawna Hills, Lower Burma. MALAYSIA: Sarawak, Borneo (type-locality); Malacca. Also SINGAPORE, INDONESIA (Sumatra) and THAILAND.

### 86. *Schedorhinotermes tiwarii* Roonwal and Thakur (Figs. 280-282)

*Schedorhinotermes tiwarii* Roonwal and Thakur:

1963. Roonwal and Thakur, *Indian J. Agric. Sci.*, 33(2) : 109-117. S major and minor and W. Holotype : S major, in ZSI, Calcutta. Type-locality : Chouldhari, South Andaman Island, Bay of Bengal, India. Types examined.

1970. Roonwal and Bose, *Rec. zool. Surv. India*, 62 (3 and 4) : 119, 140-141.

1980. Bose, *Rec. zool. Surv. India*, 77 : 101.

1983. Chhotani, *Orient. Insects*, 17 : 120.

IMAGO. Unknown.

**SOLDIER MAJOR (Fig. 280):** Head-capsule, postclypeus and thorax yellowish brown; frons, antennae, labrum, legs and abdomen paler; mandibles yellowish basally, reddish brown distally; anteclypeus whitish, translucent. Head sparsely pilose; thorax also with a few long hairs around borders; abdomen with a row of long hairs at posterior margins of terga; legs fairly pilose. Total length 5.60-6.60 mm. Head-capsule subsquarish, slightly longer than broad (length to base of mandibles 1.68-1.85, width 1.60-1.68 mm); broadest in posterior region and converging slightly anteriorly;

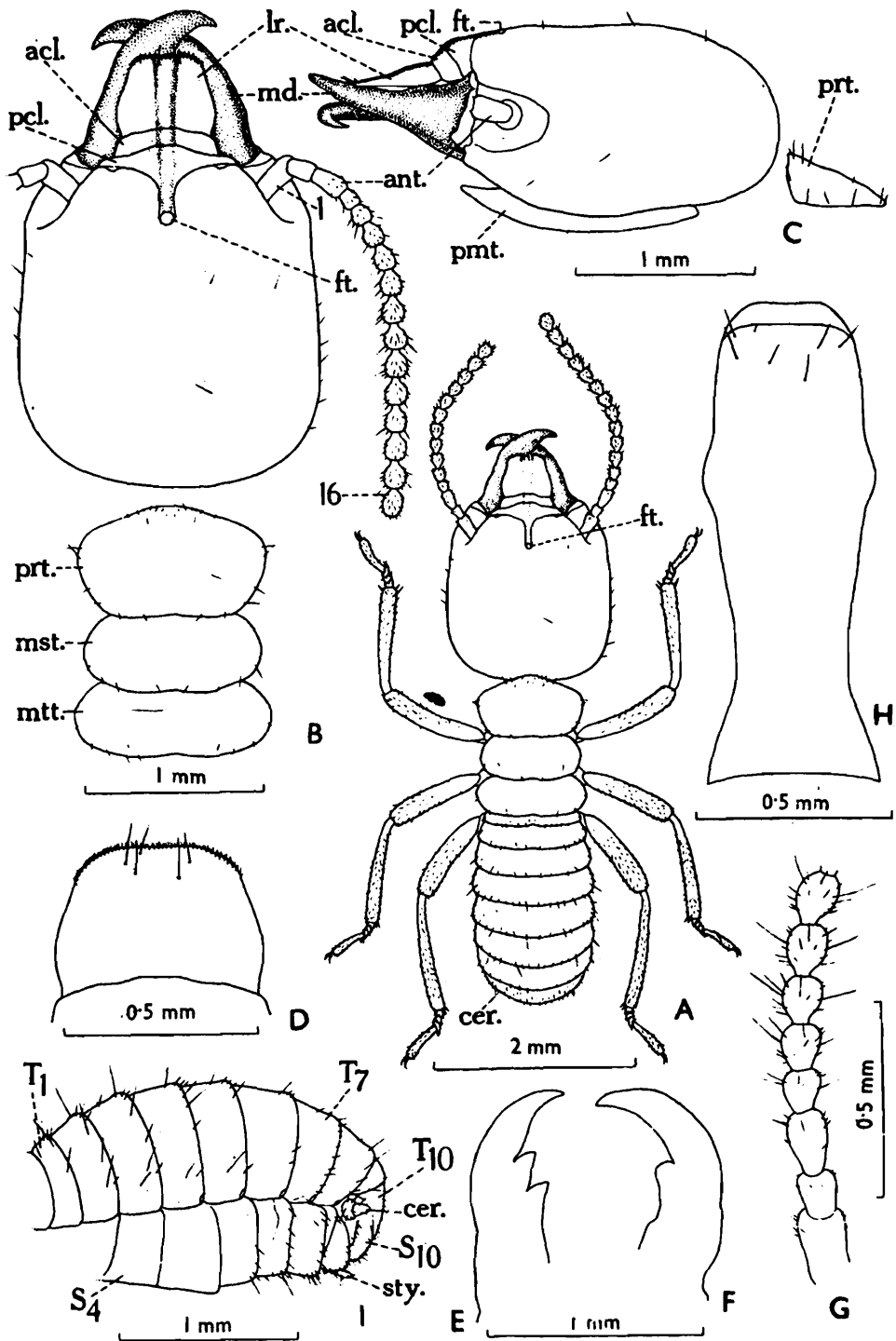

Fig. 280. *Schedorhinotermes tiwarii*. Soldier major. (A) Whole specimen, in dorsal view. (B) Head and thorax, dorsal view. (C) Head and pronotum, side view. (D) Labrum. (E) and (F) Left and right mandibles. (G) Basal part of antenna. (H) Post-mentum. (I) Abdomen, in side view.

acl., anteclypeus, ant., antenna; cer., cercus; ft., fontanelle; lr., labrum; md., mandible; mst., mesonotum; mtt. metanotum; pcl., postclypeus; pmt., postmentum; prt., pronotum; S<sub>4</sub>-S<sub>10</sub>, abdominal sternites 4 to 10; sty., stylet; T<sub>1</sub>-T<sub>10</sub>, abdominal tergites 1-10. (After Roonwal and Thakur 1963.)

posterior margin rounded. Fontanelle small, circular, translucent situated a little behind postclypeus; a narrow, shallow groove widening anteriorly, running from fontanelle to tip of labrum. Eyes and ocelli absent. Antennae with 16 segments; segment 3 longer than 2; 4 shortest. Postclypeus narrow, not well differentiated from frons; anteclypeus narrow, translucent. Labrum broad tongue-shaped; extending up to 1st marginal tooth of left mandible; wider than long, widest at posterior one-third (width 0.50-0.53, length 0.33-0.40 mm); sides converging to a slightly shorter substraight and medially weakly depressed anterior margin having 2-3 pairs of longish hairs and a fringe of small hairs. Mandibles 0.96-1.02 mm long, robust; broad at base and strongly incurved at apices. Left mandible with two prominent, pointed marginal teeth at about middle of inner margin. Right mandible with one blunt, prominent tooth at distal one-fourth and a weak projection in posterior third. Postmentum club-shaped, long (median length 1.12-1.18 mm); broadest at anterior one-third (maximum width 0.43-0.50 mm) and then gently narrowing to a waist at basal one-third (waist width 0.30-0.33 mm). Pronotum sparsely pilose, flat, much broader than long (length 0.60-0.63, maximum width 1.00-1.09 mm); anterior margin projected medially; posterior margin substraight with weak median incurving. Legs pilose, femora and tibiae long, slender, tibial spurs 3:2:2, the outer or dorsal spur in foreleg shorter than other spurs; tarsi 4-jointed. Abdomen subcylindrical, each tergite with a row of longish hairs at posterior margin; cerci 2-segmented; styli one-segmented.

**SOLDIER MINOR (Fig. 281):** Head-capsule, labrum, postclypeus, thorax and abdomen yellowish; mandibles basally yellowish brown, apically light brown; anteclypeus whitish, translucent. Head and thorax sparsely pilose; abdomen with hairs at posterior margins of terga. Total length 3.65-4.09 mm. Head-capsule suboval, little longer than broad (length to base of mandibles 0.90-1.07, width 0.76-0.90 mm); broadest near base of antennae from whence sides sharply converging anteriorly and gently narrowing posteriorly to rounded posterior margin. Fontanelle small, circular, situated a little behind postclypeus; a shallow groove runs from fontanelle to tip of labrum. Eyes and ocelli absent. Antennae with 15 segments; segment 3 shorter and narrower than 2 or 4. Postclypeus narrow, yellowish; projected in front medially, apilose. Labrum subrectangular, flap-like, extending beyond or upto tip of mandibles; longer than broad (length 0.36-0.45, width

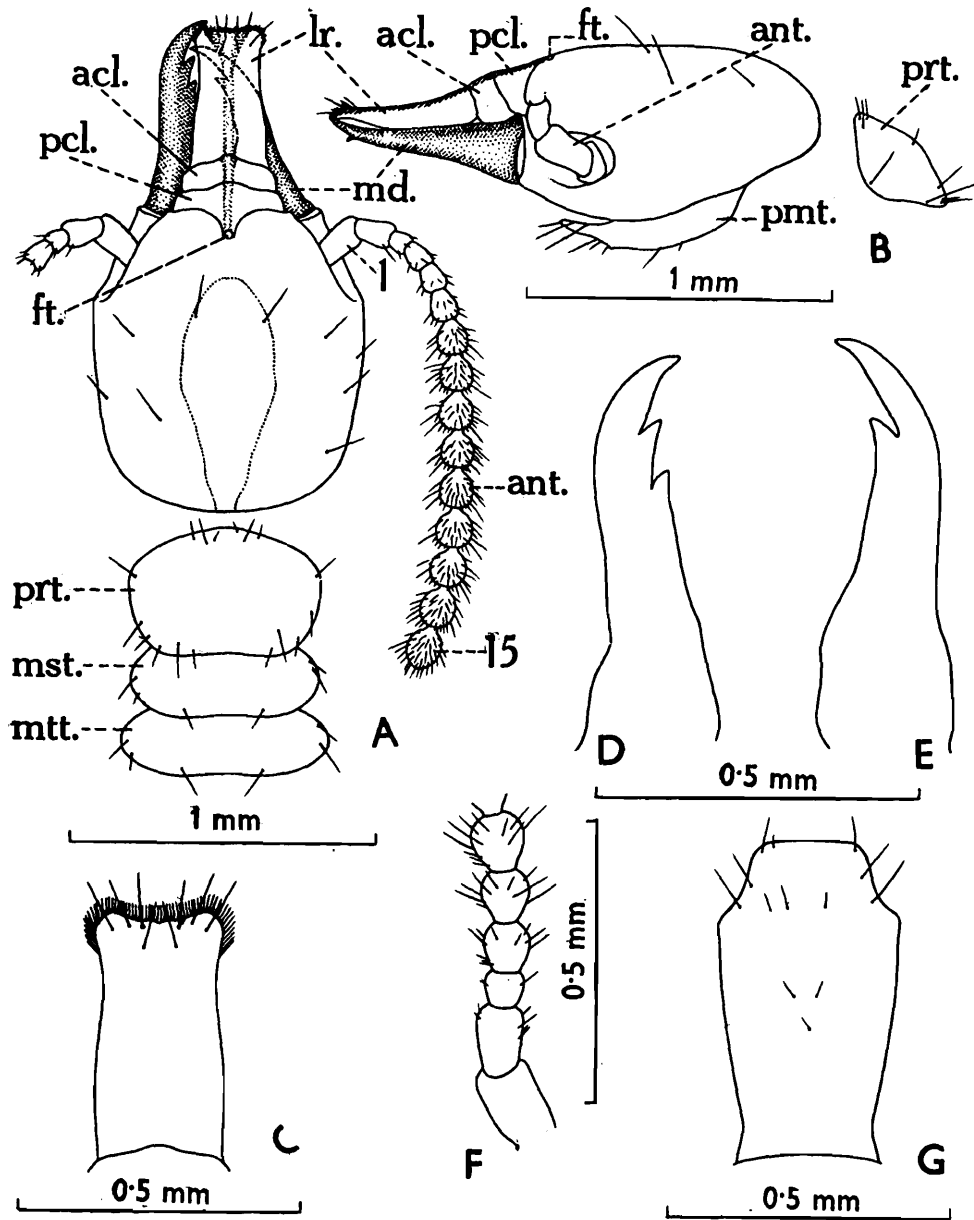

Fig. 281. *Schedorhinotermes tiwarii*. Soldier minor. (A) Head and thorax, dorsal view. (B) Head and pronotum, side view. (C) Labrum. (D) and (E) Left and right mandibles. (F) Basal part of antenna. (G) Postmentum. Lettering as in figure 280. (After Roonwal and Thakur 1963.)

0.20-0.25 mm); anterior margin weakly incurved and fringed with short hairs 'daubing brush' Mandibles long slender (length 0.53-0.63 mm), with slightly incurved pointed tips. Left mandible with two subequal, forwardly pointed, marginal teeth in anterior third and right with one tooth in corresponding position. Postmentum broadly club-shaped (length 0.53-0.60, maximum width 0.30-0.36 mm); widest at anterior end, from whence narrowing gradually to a waist very close to base (width at waist 0.23-0.26 mm). Pronotum flat, broader than long (width 0.56-0.63, length 0.40-

0.45 mm); posterior margin weakly concave medially; with a few hairs along margins and body. Legs and abdomen as in soldier major.

**WORKER (Fig. 282):** Head-capsule, labrum, postclypeus and mandibles pale yellow; antennae, thorax and abdomen paler; anteclypeus translucent. Head, thorax and body moderately pilose, abdominal tergites with a row of hairs at posterior margins and some irregular ones on body; legs weakly hairy. Total length 5.50-6.00 mm. Head-capsule subsquarish, broader than

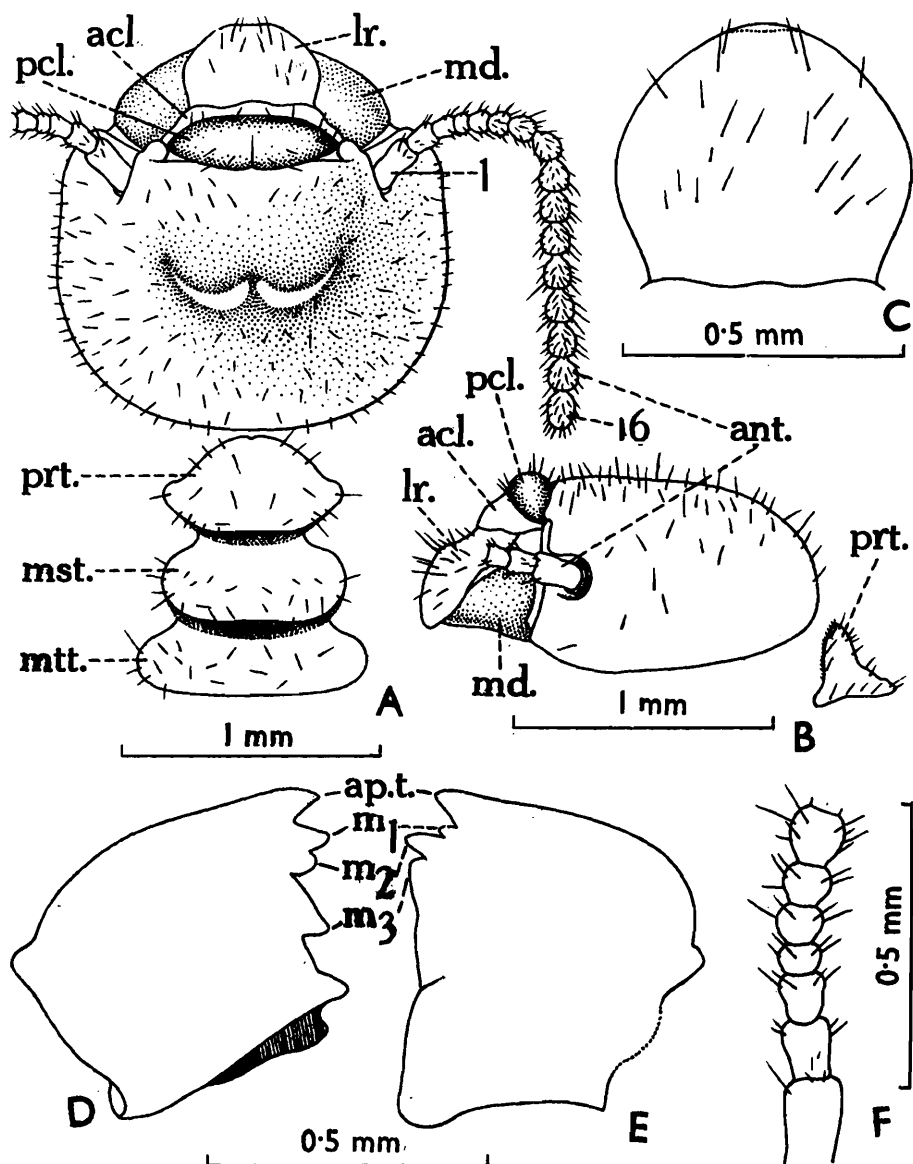

Fig. 282. *Schedorhinotermes tiwarii*. Worker. (A) Head and thorax, dorsal view. (B) Head and pronotum, side view. (C) Labrum. (D) and (E) Left and right mandibles. (F) Basal part of antenna.

acl., anteclypeus; ant., antenna; ap.t., apical tooth of mandible; lr., labrum; m<sub>1</sub>, m<sub>2</sub> and m<sub>3</sub>, 1st, 2nd and 3rd marginal teeth; md., mandible; mst., mesonotum; mtt., metanotum; pcl., postclypeus; prt., pronotum. (After Roonwal and Thakur 1963.)

long (length to base of mandibles 1.15-1.30, width 1.35-1.45 mm); sides subparallel, posterior margin broadly rounded. Fontanelle eyes and ocelli absent. Antennae with 16-17 segments; segment 3 subequal, or shorter and narrower than 2; segment 4 shortest. Postclypeus large, well differentiated from frons and with a few hairs; incompletely divided into right and left lobes; anteclypeus narrow, apilose. Labrum large, dome-shaped, broader than long, widest in middle (width 0.50-0.56, length 0.36-0.40 mm); with a few hairs on body. Mandibles as in genus. Pronotum saddle-shaped, much broader than long (width 0.66-0.79, length 0.33-0.44 mm); anterior margin strongly convex and faintly notched; posterior margin substraight. Legs and abdomen as in soldier.

*Distribution:* INDIA: Andaman and Nicobar Islands: South Andamans: Chouldhari, type-locality and Wrafter's Creek, Baratang. Little Andamans: Laitora Forest, 15 km N of Tokoibuea.

### 87. *Schedorhinotermes translucens* (Haviland)

(Figs. 283-285)

#### 1. *Termes translucens* Haviland:

1898. Haviland, *Trans. Linn. Soc., London*, 26(169) : 394. Im and S major and minor, W. Holotype: Not designated, syntypes probably in Univ. Museum of Zoology, Cambridge, Type-locality: Sarawak (Malaysia).

#### 2. *Rhinotermes (Schedorhinotermes) translucens* (Haviland):

1911. Holmgren, *K. Sv. Vet. Akad. Handl.*, 46(6) : 79.

1911. Holmgren, *Mitt. Berlin Zool. Mus.*, 5(3) : 458.

1913. Holmgren, *K. Sv. Vet. Akad. Handl.*, 50(2) : 83.

1913-1914. Holmgren, *Zool. Jb. (Syst.)*, 36(2-3) : 240-241.

1942. Hill, *Termites (Isoptera) Australian Region* : 199-201.

#### 3. *Schedorhinotermes translucens* (Haviland):

1949. Snyder, *Smiths. misc. Colls.*, 112: 96.

1958. Ahmad, *Biologia*, Lahore, 4(1-2) : 78, 80.

1975. Akhtar, *Bull. Dept. Univ. Panjab (N.S.)*, Lahore, Art. 7 : 52-58.

1983. Chhotani, *Orient. Insects*, 17 : 120.

#### 4. *Schedorhinotermes brevialetus* (Haviland). Wrong determination:

1977. Lahiri, Ghosh and Biswas, *Bull. Meghalaya Sci. Soc.*, 2 : 36.

IMAGO (Fig. 283): Head-capsule light reddish brown; pronotum lighter than head and abdomen darker; labrum and legs brownish yellow; antennae

light brownish yellow; postclypeus brownish yellow with brown median line. Head with a few scattered bristles; postclypeus with a few hairs along anterior margin; labrum with a few hairs near tip and on body; pronotum with long bristles on margins and a few on body. Total body-length with wings 12.0-14.5, without wings 8.0-9.0 mm. Head-capsule subrounded; sides without eyes substraight; broader than long (width with eyes 1.67-1.90, length to base of mandibles 1.42 mm); posterior margin rounded. Fontanelle small, circular, situated medially. Eyes suboval, large, bulging (maximum diameter of eye 0.54, short diameter 0.46 mm). Ocelli oval (long diameter 0.17, short diameter or width 0.12 mm); separated from eyes by 0.05 mm distance, much less than their short diameter. Antennae with 20 segments; segment 3 much longer than 2. Postclypeus large, conical with a broad base and round medially projecting tip; anteclypeus covered by

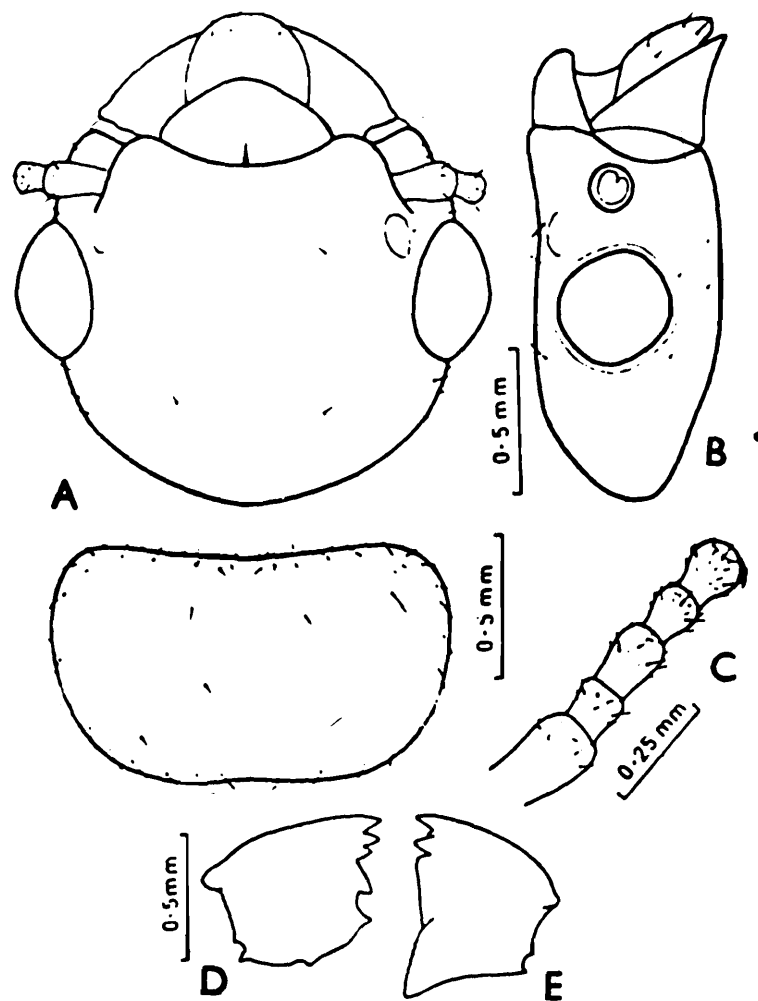

Fig. 283. *Schedorhinotermes translucens*. Imago. (A) Head and pronotum, dorsal view. (B) Head, side view. (C) Basal part of antenna. (D) and (E). Left and right mandibles. (After Akhtar 1975.)

overhanging postclypeus. Mandibles as in genus. Labrum dome-shaped, much broader than long. Pronotum flat, subrectangular, much broader than long (width 1.48-1.63, length 0.80-0.90 mm); anterior margin substraight without notch; posterior margin shallowly depressed in middle. Wings hyaline, strongly reticulate; media close to cubitus with 4-5 branches from the middle. Cubitus with about 10 branches. Apical tibial spurs 3:2:2.

**SOLDIER MAJOR (Fig. 284) :** Head-capsule, postmentum and pronotum yellowish to reddish yellow; labrum and abdomen slightly paler, straw yellow; mandibles brownish to reddish brown, basally lighter; legs yellowish brown. Head and body sparsely hairy. Total body-length c 6.0 mm. Head-capsule subsquarish, little longer than broad, length 1.59-1.88 mm, width 1.49-1.84 mm; widest at posterior half. Fontanelle circular, situated anteriorly; with a groove running in front to tip of labrum. Postclypeus broader than long with a median groove. Labrum slightly broader than long, broadest below middle; with a few hairs on body and a fringe of hairs forming a "daubing brush" on anterior margin. Mandibles sickle-shaped, 0.90-1.10 mm long. Left mandible with two marginal teeth in middle third

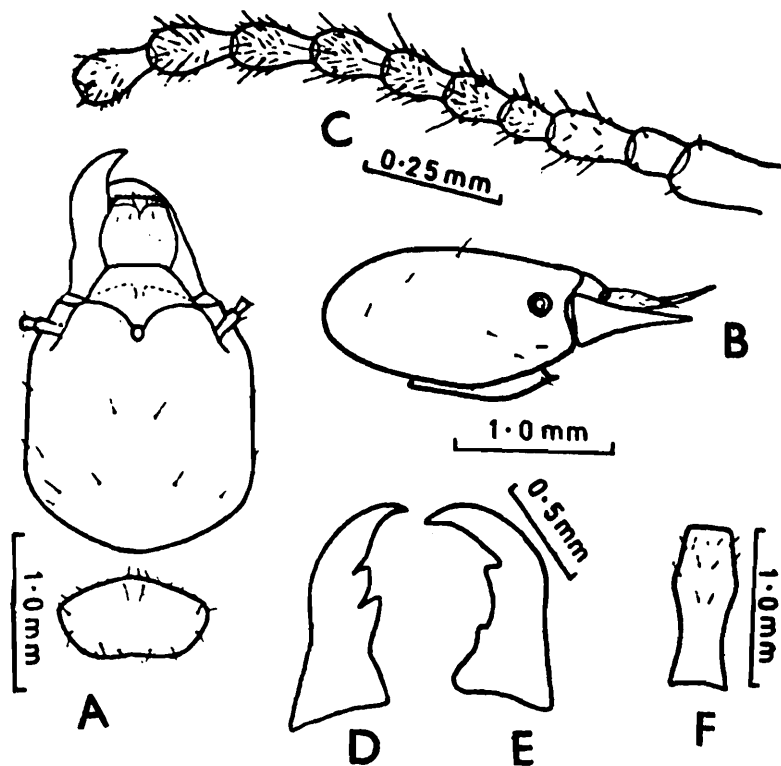
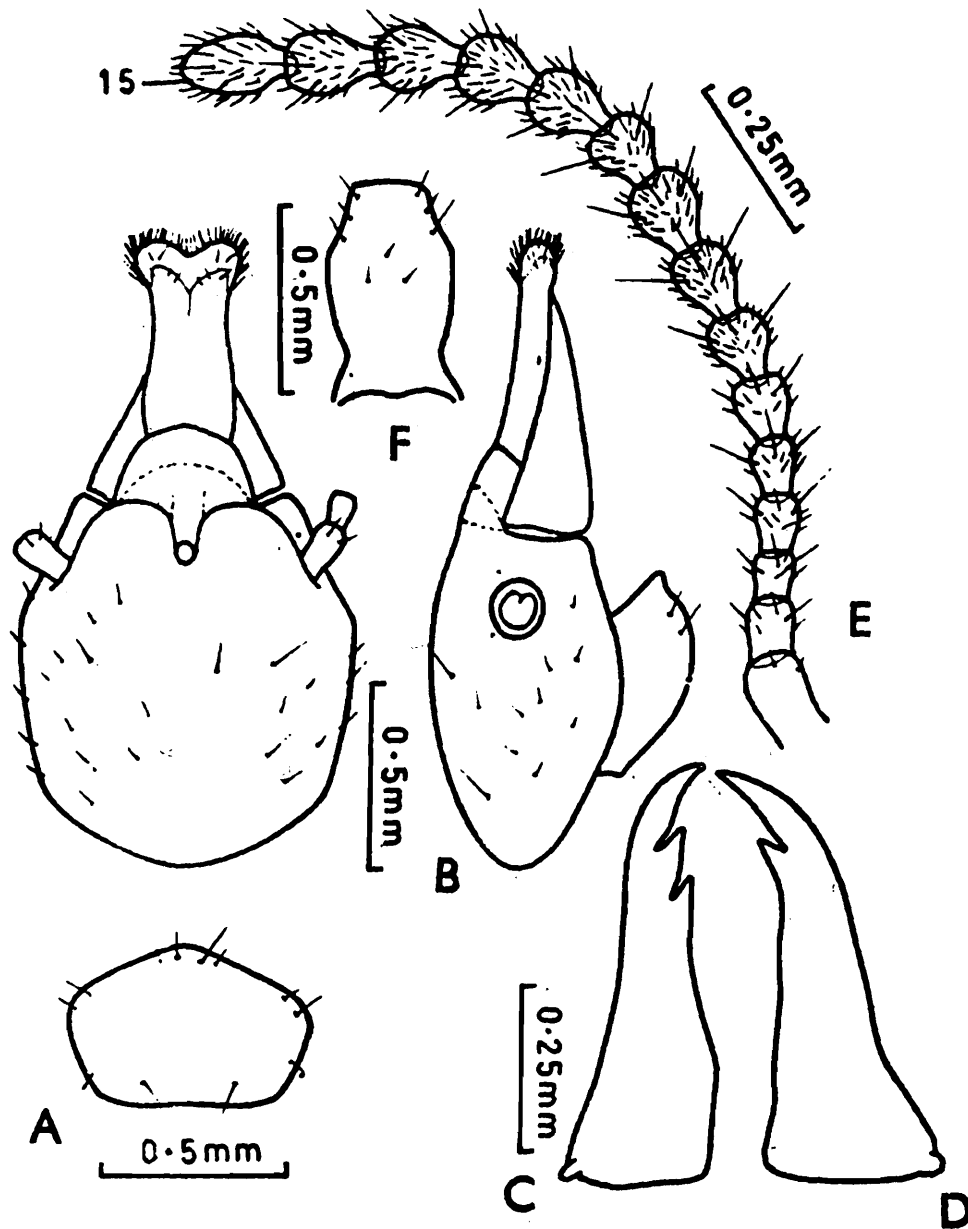

Fig. 284. *Schedorhinotermes translucens*. Soldier major. (A) Head and pronotum, dorsal view. (B) Head, side view. (C) Basal part of antenna. (D) and (E) Left and right mandibles. (F) Postmentum. (Redrawn from Akhtar 1975.)

of mandible. Right also with a well indicated first marginal and weakly developed second. Antennae with 16-17 segments; segment 3 nearly one and a half times as long as 2; 4 shortest. Postmentum sparsely pilose, moderately club-shaped, longer than broad (length 1.00-1.21 mm); broadest at anterior one-third (maximum width 0.41-0.46 mm); sides narrowing to a waist at posterior one-third (minimum width at waist 0.28-0.33 mm). Pronotum sparsely pilose with long and short hairs along margins and on body; slightly raised and convex anteriorly; much broader than long (width 0.95-1.13, length 0.51-0.61 mm); sides converging posteriorly; posterior margin slightly emarginate. Tibial spurs 3:2:2; tarsi 4-jointed.



**SOLDIER MINOR (Fig. 285) :** Head-capsule, pronotum and abdomen brownish yellow; postclypeus slightly darker; antennae slightly lighter than head; mandibles brownish; legs pale. Head with a few long bristles and hairs; labrum with a fringe of minute hairs on anterior margin and a few behind it; pronotum and abdomen with a few bristles and short hairs. Total body-length c 4.0 mm. Head-capsule subsquarish a little longer than broad (length to base of mandibles 0.74-1.07, width 0.69-0.98 mm); widest a little behind antennae, thence sides slightly converging to a convex posterior margin. Fontanelle circular, situated anteriorly; with a groove running in front upto tip of labrum. Antennae with 15-16 segments, segment 3 shortest. Postclypeus broader than long with median groove; anteclypeus short, hyaline. Mandibles thin and delicate (0.54-0.73 mm long). Left mandible with two marginal teeth on inner margin in anterior one-fourth; right with one marginal tooth very close to apex. Labrum long, rectangular; extending beyond tip of mandibles; anterior margin bilobed with a fringe of hairs. Postmentum arched, widest and bulging at anterior one-third (length 0.46-0.67, max. width 0.28-0.33 mm) from whence sides converging anteriorly to a short anterior margin and posteriorly to a broad waist (waist width 0.21-0.26 mm) and then widening out to a concave posterior margin. Pronotum broader than long (width 0.46-0.60, length 0.30-0.46 mm); with anterior margin convex and slightly produced in front; posterior margin weakly depressed medially. Tibial spurs 3:2:2, tarsi 4-jointed.

**WORKER:** Head yellowish; body straw-yellow. Head moderately pilose; abdominal tergites with two irregular rows of bristles. Total length 4.5-5.0 mm. Head yellowish; body straw-yellow. Head moderately pilose; abdominal tergites with two irregular rows of bristles. Total length 4.5-5.0 mm. Head almost squarish; head-width 1.34-1.46 mm. Fontanelle and head-sutures indistinct. Postclypeus swollen, short. Antennae 16 to 17-segmented, 3 as long as 2 in 16-segmented or shorter than 2 in 17-segmented one. Pronotum weakly saddle shaped, (pronotum width 0.64-0.72 mm), anterior margin triangular, not incised.

*Distribution:* INDIA (Meghalaya). BANGLADESH. MALAYSIA: Sarawak, Borneo (type-locality). INDONESIA: (Java, Macassar, New Guinea).

### Family V STYLOTERMITIDAE Holmgren and Holmgren\*

The small family Stylotermitidae (living forms, Chinese and Oriental) is unique in having 3-segmented tarsi (a character which it shares with another small Oriental family the Indotermitidae), all other termite families having either 4 or 5 tarsal segments. Fossil forms have been found from Eocene, Miocene and Oligocene formations from North America and Europe.

#### 1. Stylotermitinae (of family Mesotermitidae) Holmgren and Holmgren:

1917. Holmgren and Holmgren, *Mem. Dept. Agric. India (Ent.)*, 5(3) : 141.

#### 2. Stylotermitinae (of family Rhinotermitidae) Holmgren and Holmgren:

1949. Snyder, *Smiths. misc. Colls.*, 112 : 75, 366.

1955. Weidner, In *Die Termiten* (Ed. Schmidt) : 56.

1959. Mathur and Chhotani, *Zool. Anz.*, 163 (1&2) : 40-53.

1962. Mathur and Thapa, *J. Timber Dryers & Preserv. Assoc. India*, 8(4) : 4.

1965. Emerson, *Amer. Mus. Novit.*, No. 2236 : 17.

1970. Krishna, In *Biol. of Termites* (Eds. Krishna and Weesner) Vol. 2 : 138.

1970. Roonwal, In *Biol. of Termites* (Eds. Krishna and Weesner) Vol. 2 : 335.

1970. Weidner, *Handb. d. Zool.*, 4, Sec. 2 (Ins.) Pt. 2, Lief. 13, No. 14 (Isoptera) : 21

1971. Emerson, *Bull. Am. Mus. nat. Hist.*, 146 (Art. 3) : 287.

1986. Grasse', *Termitologia* Vol. 3 : 527-528.

#### 3. Stylotermitidae Holmgren and Holmgren:

1963. Chatterjee and Thakur, *Indian Forester*, 89(9) : 635, 637 (Nomen nudum).

1964. Chatterjee and Thakur, *Zool. Anz.*, 173 (2) : 149, 159.

1972. Chhotani, In *Termite Problems in India* (Ed. Roonwal) : 24. (CSIR Publ.)

1975. Roonwal, *Biol. Zbl.*, 94 : 27-43.

1977. Chhotani, *Proc. 8th int. Congr. Int. Un. Study Social Insects* (Wageningen 1977): 116, 117.

1979. Roonwal, Verma and Thakur, *Proc. Indian natnl. Sci. Acad.*, (B) 45 : 125, 126.

1981. Roonwal, *Proc. Indian natnl. Sci. Acad.*, (B) 47 : 468, 471.

---

\*Note : The family name Stylotermitidae was first used by Chatterjee and Thakur (1964), but Holmgren and Holmgren (1917) had already used this name as a subfamily Stylotermitinae. According to International Rules of Zoological Nomenclature, the latter authors also become the authors of the family when the subfamily is raised to that rank.

1982. Thapa, *Sabah For. Rec.*, No. 12 : 4.  
 1983. Roonwal, *Proc. Indian natnl. Sci. Acad.*, (B) 49 (5) : 378-379, 387.  
 1983. Maiti, *Occ. Pap. Rec. zool. Surv. India*, No. 42 : 22.  
 1983. Chhotani, *Oriental Insects*, 17 : 115-117, 120-121.  
 1984. Bose, *Occ. Pap. Rec. zool. Surv. India*, No. 49 : 14, 74.  
 1985. Chhotani, *Z. ang. Ent.*, 100 : 90-91.  
 1985. Roonwal, *Zool. Anz.*, 215 : 224.

Type genus : *Stylotermes* Holmgren and Holmgren.

1. *Characters of Family Stylotermitidae*  
 (Figs. 286, 287)

*Imago* : Dark brown. Head subcircular; epicranial suture present or absent. Fontanelle very small, round to oval; fontanelle gland small. Labrum dome-shaped in outline. Postclypeus weakly to strongly swollen; with or without a median longitudinal suture. Mandibles with an apical and 3 marginal teeth ( $m_1 - m_3$ ). Left mandible with the apical,  $m_1$  and  $m_3$  large;  $m_2$  very small. Right mandible with  $m_1$  vestigial, rest well developed. Eyes and ocelli present, well developed. Antennae with 16-22 segments (16-17 in *Parastylotermes*, 18-22 in *Stylotermes*). Pronotum flat, narrower than head; anterior and posterior margins with a weak median notch. Tibia slender; apical tibial spurs 3:2:2 (*Stylotermes*\*) or 2:2:2

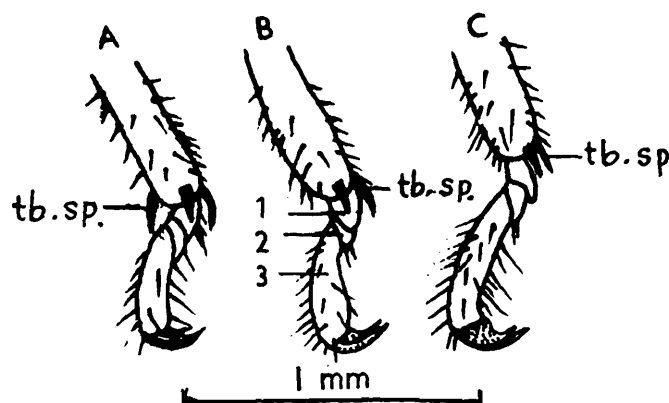

Fig. 286. *Stylotermes bengalensis*. Soldier. Distal part of legs, showing 3-segmented tarsi. 1,2,3, first, second and third tarsal segments; tb. sp., tibial spur.

\*Holmgren and Holmgren (1917, p. 141) erroneously gave 3 apical tibial spurs in *Stylotermes* in all the legs.

(*Parastylotermes*). Tarsi 3-segmented. Wings : Not hairy, except on scales. Wing membrane reticulated, with numerous fine 'veinlets'. Forewing : Scale larger than in hindwing; costa and radius strong, joined by several cross-veins; media and cubitus close and parallel; media usually unbranched, rarely bifurcated; cubitus arising inside scale and with numerous (c 19-23) branches. Hindwing : Media arising from radius outside scale; a short anal present (vide Emerson, 1971, p. 289); rest as in forewing. Wings covered on both sides with a fine and dense microsculpturing of cuticular elements which are of 3 types; a few rows of weakly pointed papillae at the anterior margin; rows of arrow heads (sometimes with external teeth) on the anterior and other veins; and minute pimpules on lower and proximal parts of membrane; no micrasters present (Roonwal, Verma and Thakur, 1979a; Roonwal 1981a, 1983c; Roonwal 1985a SEM study). Cerci small, 2-jointed. Styli absent.

*Soldier* : Rather large, looking somewhat like soldiers of the Kalotermitidae. Fontanelle present, minute. Head strong, longish, subrectangular. Labrum dome-shaped in outline, narrowing proximally; without a hyaline tip. Mandibles stout, sabre-shaped, slightly shorter than head; broad at base, with pointed incurved tip; inner margin with one or two minute tooth-like crenulations in basal half. Eyes vestigial, present as spots. Ocelli minute or absent. Antennae with 13-19 segments; 2 shortest; 3 longer than 2. Postmentum long, club-shaped; with a narrow waist. Pronotum flat, broader than long; anterior margin with a small or prominent median notch; posterior margin with or without a median notch. Femora somewhat swollen; tibia slender; apical tibial spurs 3:2:2 (*Stylotermes*); tarsi 3-segmented (Fig. 286). Cerci small, 2-jointed. Styli absent.

*Worker* : Pale and small. Head rounded. Fontanelle present (minute) or absent. Postclypeus narrow. Mandibles as in imago. Antennae with 15-20 segments; segment 2 longer than 3 or 4. Pronotum flat, broader than long; anterior margin sometimes slightly raised. Meso- and metanota with (*Stylotermes fletcheri*) or without lateral pleural processes\* (Fig. 287).

---

\*In *S. fletcheri* these pleural processes are also present in larvae and nymphs (in the latter, they are in addition to the wing-pads).

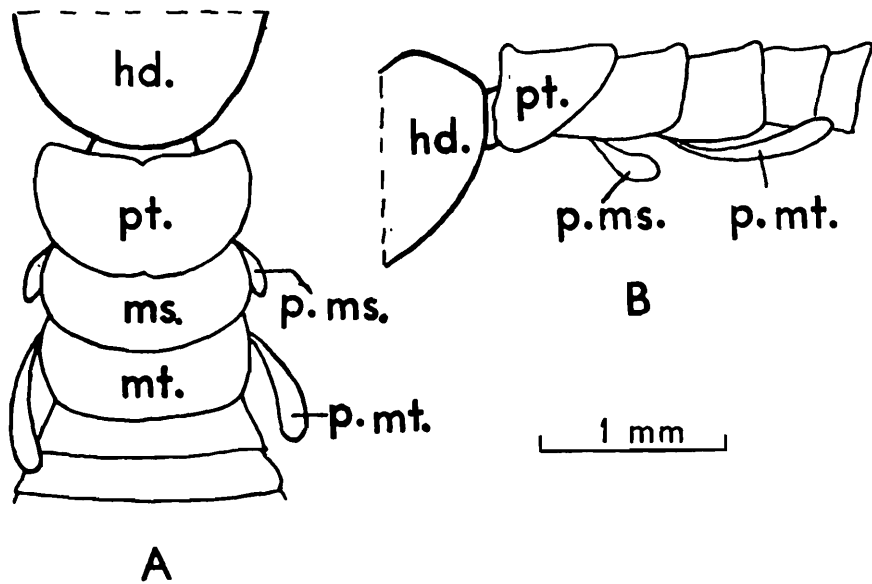

Fig. 287. *Stylotermes fletcheri*. Worker. Anterior part of body, showing pleural processes of meso- and metathorax. (A) Dorsal view. (B) Side view.

hd., head; ms., mesonotum; mt., metanotum; p.ms., pleural process of mesonotum; p.mt., pleural process of metanotum; pt., pronotum (After Roonwal 1975).

## 2. Distribution and Composition of Stylotermitidae

**Distribution** : Living : Oriental Region (India; Bangladesh; China and Sabah (Malaysia)). Fossil : Upper Eocene to Miocene : N. Europe and N. America (Washington).

**Composition** : 1. *Stylotermes* Holmgren & Holmgren 1917. Synonyms : *Sarvaritermes* Chatterjee & Thakur 1964; and *Operculitermes* Yu and Ping 1964b, *vide* Emerson in Krishna, 1970, p. 138 and Emerson, 1971, p. 288.

2. *Parastylotermes* Snyder & Emerson (in Snyder), 1949, p. 366. Fossil only; imago and wing. Upper Eocene, Oligocene, Miocene. Northern Europe (Baltic Amber and East Prussia; and North America (Washington, U.S.A.).

## 3. Phylogeny of Stylotermitidae

(Fig. 288)

Stylotermitidae possesses some characters of both the Kalotermitidae and the Rhinotermitidae, but is closer to the latter. It arose from the

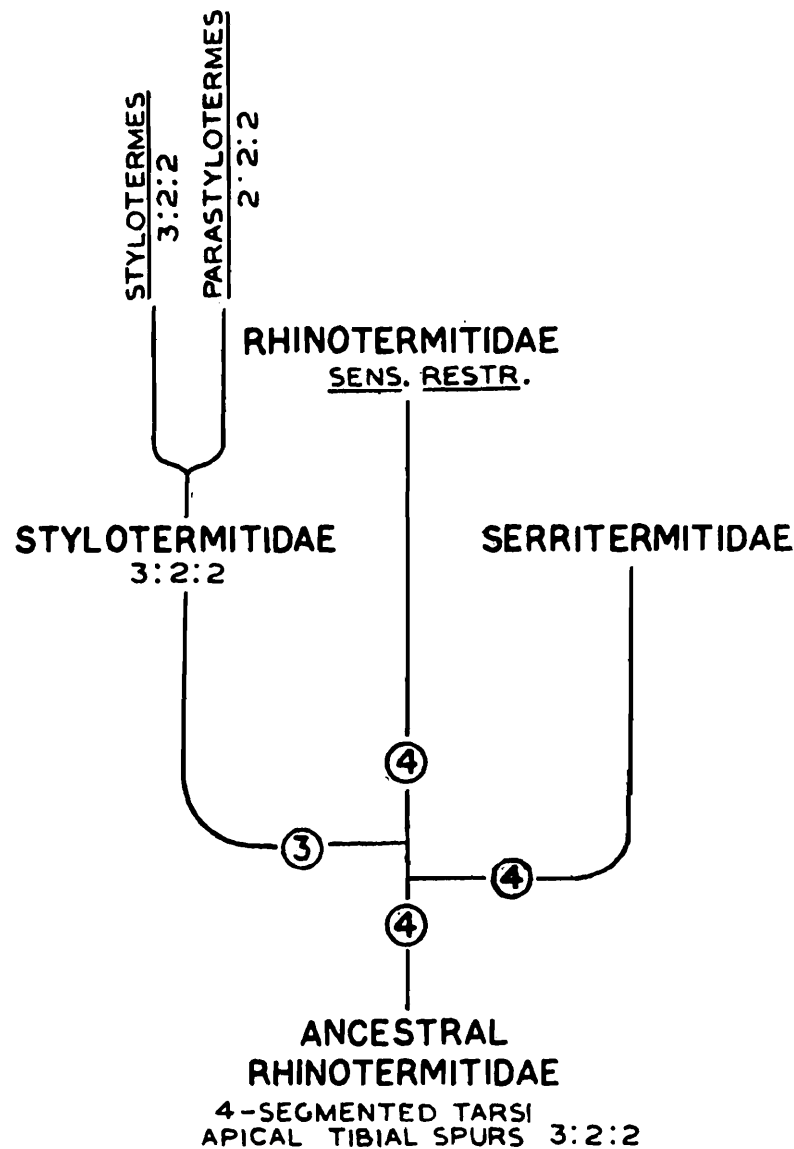

Fig. 288. Chart showing the hypothetical evolution of the family Stylotermitidae. Encircled numerals indicate the number of tarsal segments and the formulae indicate the number of apical tibial spurs in the fore-middle-and hindlegs, respectively. (After Roonwal 1975a.)

ancestral rhinotermitid stock (with 4 tarsal segments) after the separation of the more primitive family Serritermitidae. Thereafter two branches arose: one the modern Rhinotermitidae (*sens. str.*) which retained the 4-segmented tarsi; and the other the Stylotermitidae with 3 tarsal segments. For detailed discussion of phylogeny and status, *vide* Roonwal, 1975a.

**Genus 21. *Stylotermes* Holmgren and Holmgren**  
(Synonyms : *Sarvaritermes* Chatterjee and Thakur,  
*Operculitermes* Yu and Ping)

1. Genus *Stylotermes* Holmgren and Holmgren :

1917. Holmgren and Holmgren, *Mem. Dept. Agric. India (Ent.)*, 5(3): 141-144.

1934. Snyder, *Indian For. Rec. (Ent.)*, 20: 24, 27.
1949. Snyder, *Smiths, misc. Colls.*, 112: 75.
1949. Grassé, *Traite d. Zool.*, 9(Insects): 534.
1950. Ahmad, *Bull. Am. Mus. nat. Hist.*, 95: 44, 53, 54.
1955. Emerson, *Fieldiana: Zool.*, 37: 509.
1958. Ahmad, *Biologia*, Lahore, 4: 59, 72.
1959. Mathur & Chhotani, *Zool. Anz.*, 163 (1 & 2) : 40-53.
1962. Mathur & Thapa, *J. Timber Dryers & Preserv. Assoc. India*, 8(4): 4.
1970. Krishna, In *Biol. of Termites* (Eds. Krishna and Weesner) Vol. 2: 138.
1970. Roonwal, In *Biol. of Termites* (Eds. Krishna and Weesner) Vol. 2: 335.
1972. Chhotani, In *Termite Problems in India* (Ed. Roonwal) : 14.
1973. Chhotani and Bose, *Zool. Anz.*, 190(3/4): 233, 234.
1975. Roonwal, *Biol. Zentrbl.*, 94: 28.
1975. Akhtar, *Bull. Dept. Zool. Univ. Panjab (N.S.)*, Lahore, Art. 7: 36, 45-47.
1977. Chhotani, *Proc. 8th int. Cong. Int. Un. Study Soc. Insects* (Wageningen, 1977): 116.
1982. Grassé, *Termitologia* Vol. 1: 47.
1982. Thapa, *Sabah For. Rec.*, No. 12: 4.
1983. Maiti, *Occ. Pap. Rec. zool. Surv. India*, No. 42: 22.
1984. Bose, *Occ. Pap. Rec. zool. Surv. India*, No. 49: 75.
1985. Chhotani, *Zeit. ang. Ent.*, 100: 90-91, 92.
1986. Grassé, *Termitologia* Vol. 3: 527-528.
2. Genus *Sarvaritermes* Chatterjee and Thakur :
1963. Chatterjee and Thakur, *Indian Forester*, 89(9): 635. *Nomen nudum.*
1964. Chatterjee and Thakur, *Zool. Anz.*, 173(2): 149-162. (Type of genus : *Sarvaritermes faveolus* Chatterjee & Thakur)
1967. Chatterjee and Thakur, *Indian For. Rec. (Ent.)*, 11: 2, 4, 19.
1970. Roonwal, In *Biol. of Termites* (Eds. Krishna and Weesner) Vol. 2: 335.
1975. Roonwal, *Biol. Zentralb.*, 94: 28.
3. Genus *Operculitermes* Yu and Ping :
1964. Yu and Ping, *Acta ent. Sinica*, 13: 344-361. (Type of genus : *Operculitermes sinensis* Yu & Ping 1964) (Place under Rhinotermitidae, Heterotermitinae.)
1986. Grassé, *Termitologia* Vol. 3: 527.

Type of genus : *Stylotermes fletcheri* Holmgren and Holmgren.

### 1. Characters of Genus *Stylotermes*

Same as in the family Stylotermitidae. Apical tibial spurs 3:2:2 (in fossil genus *Parastylotermes*, 2:2:2).

In giving the characters of genus *Stylotermes*. Holmgren and Holmgren (1917, p. 141) make the curious statement : "Tarsi with three jointed spines", which seems to be a confusion for 3-segmented tarsi. They make no mention either of the 3-segmented tarsi or the apical spurs whereas under the family characters they mention the latter but make no mention of the 3-segmented nature of the tarsi.

### 2. Distribution and Composition of *Stylotermes*

*Distribution* (Fig. 289) : India, Bangladesh, Sabah (Malaysia), China.

*Composition* : A total of 36 species are known in *Stylotermes*; 27 from China, one from Sabah (Malaysia); one from Bangladesh and 7 from India. The eight species from the Indian Region are as follows :-

1. *S. ahmadi* Akhtar. Bangladesh
2. *S. beelsoni* Thakur. India
3. *S. bengalensis* Mathur and Chhotani. India
4. *S. chakratensis* Mathur and Thapa. India
5. *S. dunensis* Thakur. India.
6. *S. faveolus* (Chatterjee and Thakur). India
7. *S. fletcheri* Holmgren and Holmgren. India
8. *S. parabengalensis* Maiti. India.

### 3. Keys to Indian Region Species of *Stylotermes*

#### IMAGOES

- 1(4) Larger and paler species : Total length without wings 6.25-9.35, head-length to base of mandibles 1.33-1.60 and head-width 1.65-1.80 mm: head pale to bright yellowish brown

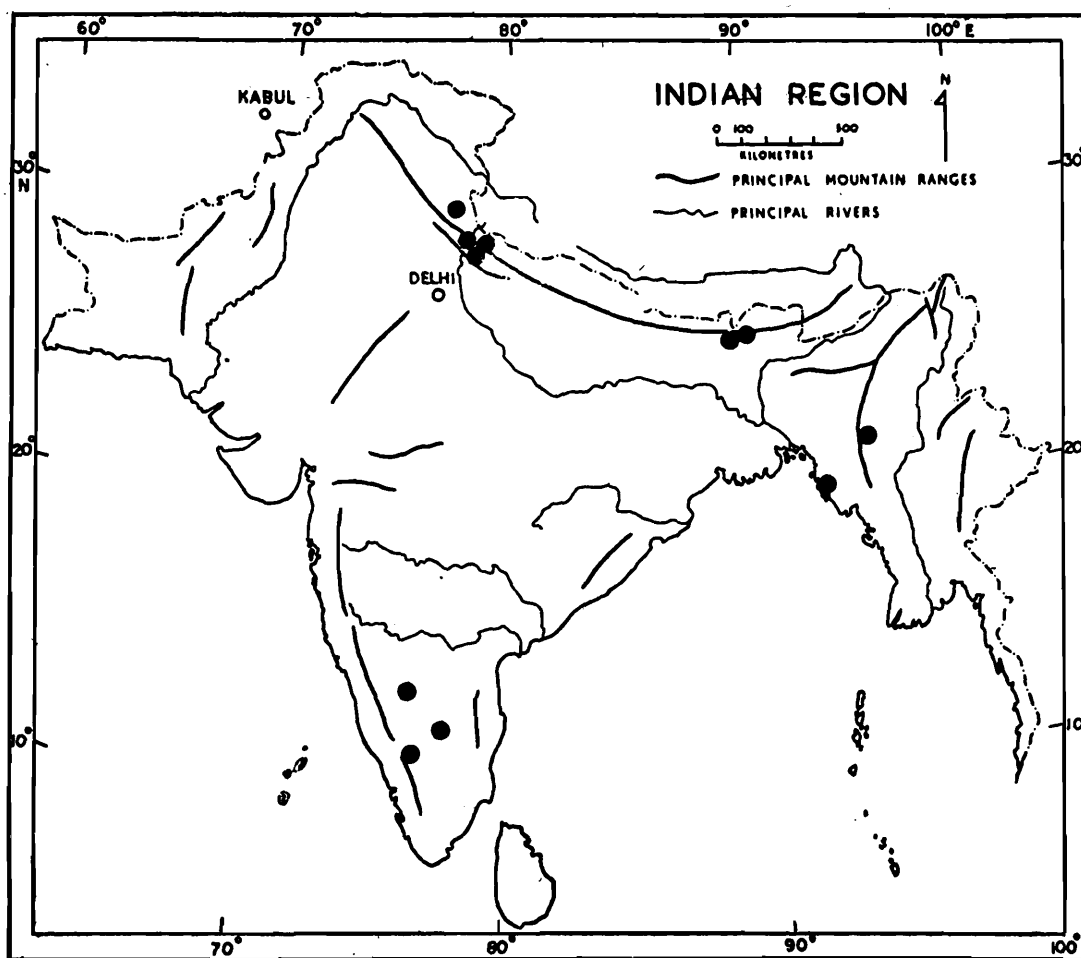

Fig. 289. Map of the Indian region, showing the distribution of genus *Stylotermes*.

- |   |                           |
|---|---------------------------|
| <p>2(3) Epicranial suture well marked. Wing scales shorter (forewing scale 1.0-1.13, hindwing scale 0.75-0.85 mm).....</p>  | <p><i>faveolus</i></p>    |
| <p>3(2) Epicranial suture faint, only posterior arm present. Wing scales longer (forewing scale 1.3-1.5, hindwing scale 0.73-0.85 mm).....</p>  | <p><i>bengalensis</i></p> |
| <p>4(1) Smaller and darker species. Total length without wings 5.30-7.6, head-length to base of mandibles 1.00-1.24 and head-width 1.25-1.55 mm; head dark brown to dark chocolate brown.</p> |                           |
| <p>5(6) Antennae 18-19 segmented. Larger in size (head-length to base of mandibles 1.18-1.24, head-width 1.45-1.55 pronotum-width 1.18-1.29 and forewing length 9.95-10.80 mm).....</p>       | <p><i>fletcheri</i></p>   |
| <p>6(5) Antennae 16-17 segmented. Smaller in size (head-length 1.00-1.13, head-width 1.25-1.30, pronotum-width 0.95-1.10 and forewing length 8.0-9.10 mm) .....</p>                           | <p><i>dunensis</i></p>    |

## SOLDIERS

- 1(4) Larger species : Head-length above 3.0 mm; head-width above 2.0 mm.
- 2(3) Head subrectangular, sides subparallel; antennal faveolae not prominent and deep; fontanelle subcircular; mandibles longer comparative to head, mandibles/head-length index 0.73-0.76..... *chakratensis*
- 3(2) Head rectangularly oval, sides slightly convexical and narrowing anteriorly; antennal foveolae prominent, deep; fontanelle oval; mandibles shorter, mandible/head length index 0.60-0.67..... *faveolus*
- 4(1) Smaller species: Head-length less than 3.0 mm; head-width less than 2.0 mm
- 5(8) Head-length 2.35-2.70, head-width 1.65-1.80
- 6(7) Mandibles thicker, strongly incurved anteriorly and longer comparative to head-length (index Mandible-length/Head-length to base of mandibles 0.72); pronotum widely incurved at anterior margin, sides straighter, comparative to head wider (index pronotum width/head width 0.95) and longer comparative to width (index Length/Width 0.66)..... *fletcheri*
- 7(6) Mandibles narrower, less so incurved anteriorly and shorter (index mandible-length/head-length to base of mandibles 0.65-0.69); pronotum convexical and incurved medially at anterior margin, sides rounded, comparative to head narrower (index pronotum-width/head-width 0.81-0.88) and shorter comparative to width (index Length/Width 0.55-0.58)..... *bengalensis*
- 8(5) Head-length 1.9-2.45 mm, head-width 1.19-1.55 mm
- 9(12) Head smaller : Length to base of mandibles 1.92-2.23, head-width 1.19-1.39 mm. Anterior margin of pronotum convexical with deep notch medially; antero-lateral angles wider
- 10(11) Mandibles comparative to head longer (index Mandible-length/Head length 0.65; mandibular teeth distinct. Head darker and wider comparative to length, index Width/Length to base of mandibles 0.64-0.65 ..... *ahmadi\**
- 11(10) Mandibles comparative to head shorter (index Mandible-length/Head-length 0.55-0.59; mandibular teeth not distinct. Head somewhat paler and narrower-Width/Length 0.60-0.62 ..... *parabengalensis\**
- 12(9) Head larger : Length to base of mandibles 2.15-2.45, head-width 1.35-1.55, mm. Anterior margin of pronotum incurved; antero-lateral corners narrower
- 13(14) Antenna thicker; 2nd segment of antenna bigger. Postmentum narrower at waist, index Min. width/Max. width 0.37-0.40..... *bessoni\**

- 14(13) Antennae narrower; 2nd segment of antenna smaller. Postmentum wider at waist, index Min. width/Max. width 0.47-0.55 ..... *dunensis*\*

\*Note : The soldiers of the species *ahmadi* Akhtar, *beesoni* Thakur, *dunensis* Thakur and *parabengalensis* Maiti are very close to each other. They are separated on some characters which may prove to be variations when larger and more extensive collections are available for study. They are, however, kept separate for the present.

### 88. *Stylotermes ahmadi* Akhtar.

(Fig. 290)

*Stylotermes ahmadi* Akhtar :

1975. Akhtar, *Bull. Dept. Zool. Univ. Panjab, (N.S.)*, Lahore, Art. 7 : 47-49. S. Holotype : S, in Zool. Dept. Panjab Univ., Lahore. Type-locality: Ukhia, Bangladesh.

1983. Chhotani, *Oriental Insects*, 17 : 120

IMAGO : Unknown.

**SOLDIER (Fig. 290):** Head-capsule reddish brown; postclypeus and antennal carinae slightly darker than head; anteclypeus whitish; labrum light brown; mandibles dark reddish brown basally, apically blackish; antennae dark reddish brown basally, light reddish brown distally; pronotum brownish; legs and abdomen brownish yellow. Head and abdomen moderately hairy; labrum with two bristles in middle and a few on anterior and anterolateral margins; postmentum with scattered bristles all over; pronotum with a few hairs and bristles on margins and a few bristles on body. Head-capsule rectangular, much longer than broad (length to base of mandibles 1.94-2.19, width 1.26-1.39 mm); sides subparallel, weakly converging anteriorly; posterior corners rounded; posterior margin convexical. Fontanelle small, circular; situated a little anterior to middle. Eyes oval, small, faint. Ocelli absent. Antennae with 13 segments; segment 2 smallest; 3 strongly sclerotized, twice as long as 2. Postclypeus not well differentiated from frons, with a few hairs. Anteclypeus apilose, translucent. Mandibles strong, stout, sabre-shaped (1.26-1.39 mm long); left mandible with indistinct dentition slightly below middle and a larger-one (knob-like process) near base. Right mandible with one denticle in basal one-third. Labrum dome-shaped, broader than long (width 0.36-0.42, length 0.29-0.33 mm); with a few long hairs on anterior margin and on body. Postmentum long (length 1.44-1.71 mm), club-shaped, club or broadest part at anterior one-third,

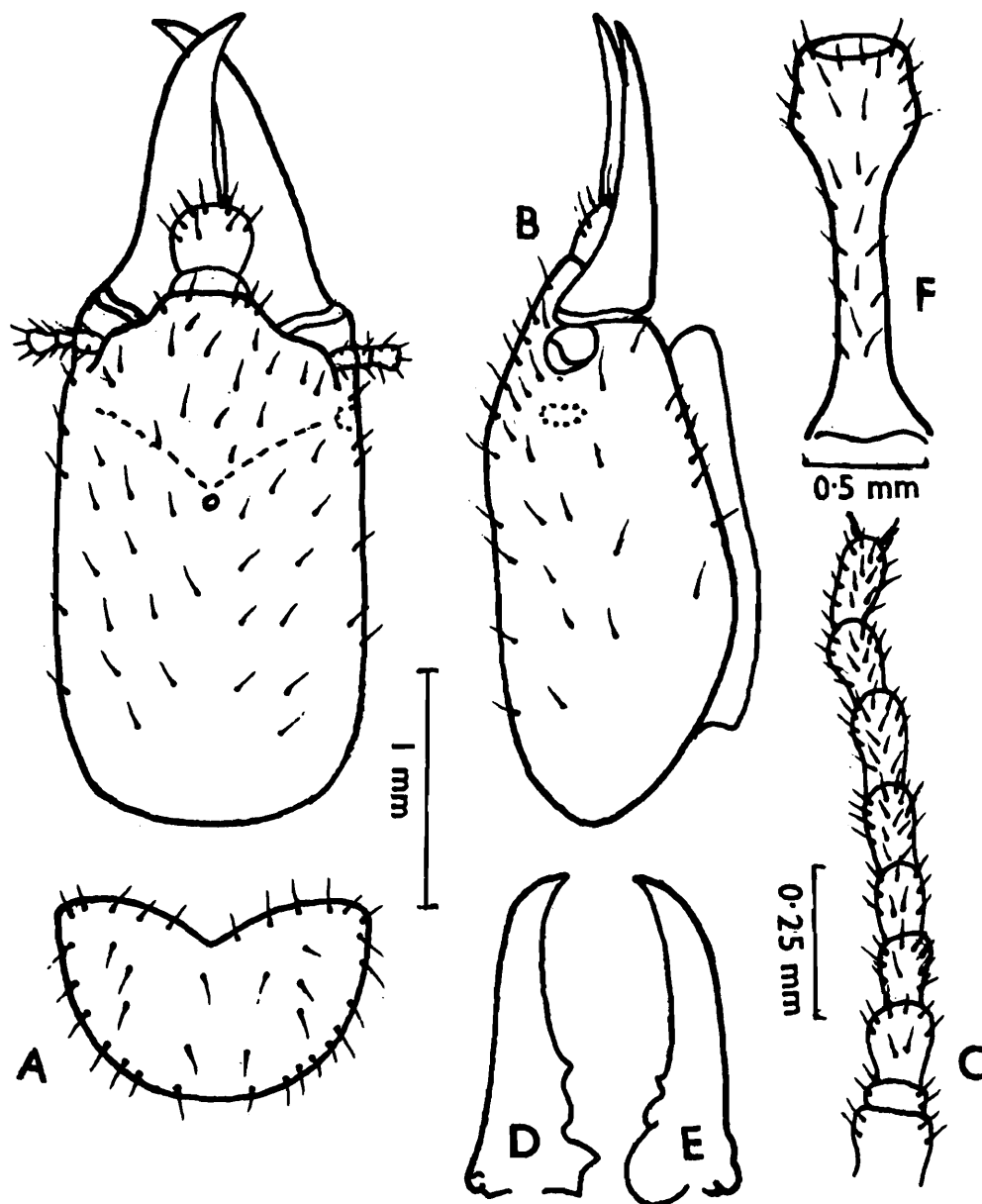

Fig. 290. *Stylotermes ahmadi*. Soldier. (A) Head and pronotum, in dorsal view. (B) Head, in side view. (C) Antenna, basal part. (D) and (E) Left and right mandibles. (F) Postmentum (Redrawn from Akhtar 1975.)

bilobed (maximum width 0.52-0.61 mm); thence sides narrowing to a long stalk or waist (minimum or waist-width 0.20-0.21 mm) and again widening out to a slightly broader posterior margin. Pronotum broader than long, a little narrower than head (length 0.62-0.73, width 1.14-1.32 mm); anterior margin convexical and deeply notched; sides convex; posterior margin substraight. Tibial spurs 3:2:2, tarsi 3-jointed.

*Distribution* : BANGLADESH : Ukhia, known only from type-locality.

**89. *Stylotermes beelsoni* Thakur**  
(Figs. 291, 292)

*Stylotermes beelsoni* Thakur:

1975. Thakur, *J. Indian Acad. Wood Sci.*, 6 (2): 94-98. S, W. Holotype : S, in FRI, Dehra Dun. Type-locality : Tiliamura, Tripura, India. Types examined.

1975. Sen-Sarma et al., *Wood Destroying Termites of India* (Final Tech. Rep. PL 480 Prog.) : 11, 52, 64.

1979. Sen-Sarma and Thakur, *Indian For. Rec. Ent. (N.S.)*, 13 (1) : 11-12.

1983. Chhotani, *Orient. Insects*, 17 : 120.

IMAGO: Unknown.

**SOLDIER (Fig. 291):** Head-capsule and antennae reddish brown, head posteriorly yellowish brown; mandibles blackish apically, reddish brown basally; abdomen whitish yellow. Head and pronotum sparsely and body moderately, pilose. Total length c 6.10-6.50 mm. Head-capsule rectangular, much longer than broad (length to base of mandibles 2.15-2.20, width 1.35-1.40 mm); sides subparallel, weakly converging in front of antennae; posterior margin rounded; frons sloping anteriorly; Y-suture faintly visible with posterior arm extending upto occiput. Fontanelle small, oval; whitish, situated in anterior one-third of head. Antennae with 9-segments; segment 2 shortest; 3 club-shaped, dark and longer than rest. Eyes small, whitish; close to antennal sockets. Ocelli minute, separated from eyes by more than long diameter of eye. Postclypeus not well demarcated from frons; with a few hairs; anterior margin straight. anteclypeus whitish, narrow; anteriorly weakly convexical. Mandibles strong and fairly long (length 1.25-1.35 mm); more than half of length of head to mandible-base (Mandible-length/Head-length index 0.58-0.63). Labrum tongue-shaped, broader than long (length 0.15-0.23, width 0.35-0.38 mm); with a few hairs on body and anterior margin. Postmentum long (length 1.15-1.65 mm), club-shaped; club divided into an anterior and a posterior part, posterior lobe being again divided, the lower lobe of which being broader (0.50-0.55 mm) and then narrowing down to a long waist (0.20 mm). Pronotum flat, subtrapezoidal; broader than long (width 1.15-1.20, length 0.70-0.75 mm); a central, hyaline, median line present; antero-lateral corners acute; anterior margin concave and with a deep median notch; posterior margin convex, without

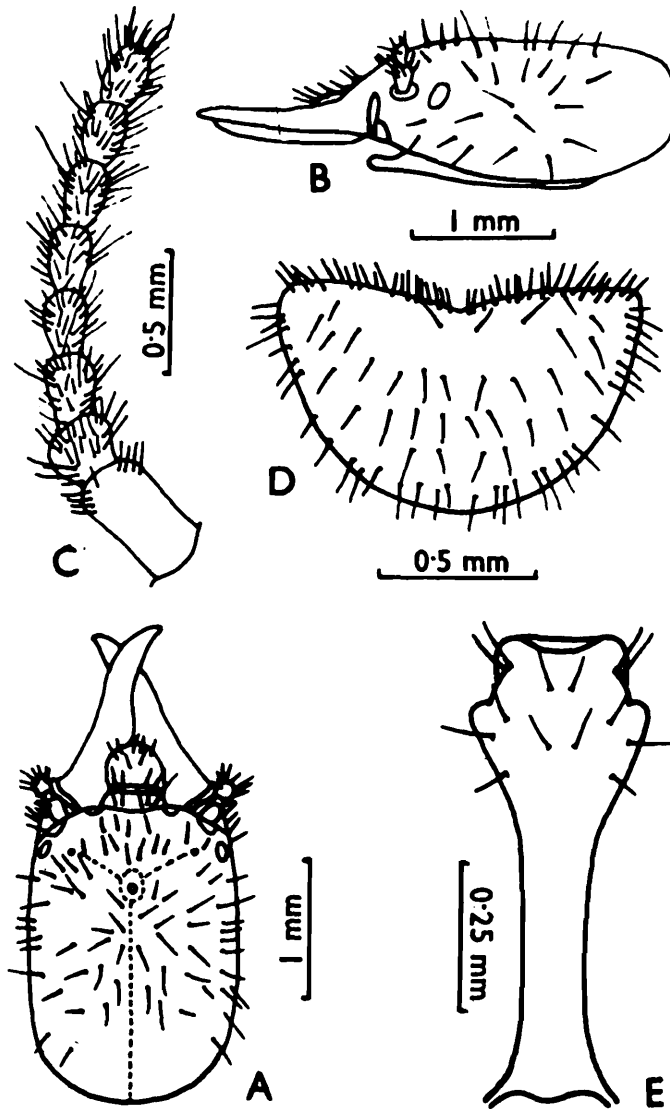

Fig. 291. *Stylotermes beesoni*. Soldier. (A) Head, dorsal view. (B) Same, side view. (C) Antenna, in part. (D) Pronotum, dorsal view. (E) Postmentum (Redrawn from Sensarma and Thakur 1979.)

notch. Legs with femora short, stout and swollen; tibiae long and slender; tibial spurs 3:2:2; tarsi 3-jointed. Abdomen oblong, pilose; cerci 2-segmented, 0.13 mm; styli absent.

**WORKER** (Fig. 292): Head-capsule, postclypeus and antennae yellowish; labrum and mandibles brownish yellow; body paler. Head moderately and body fairly, pilose. Total length 3.80-4.90 mm. Head-capsule subcircular, little broader than long (width 1.10-1.30, length to mandible-base 0.90-1.15 mm); Y-suture distinct. Fontanelle small, oval-shaped, almost in centre of head. Eyes fairly large, visible in strong light.

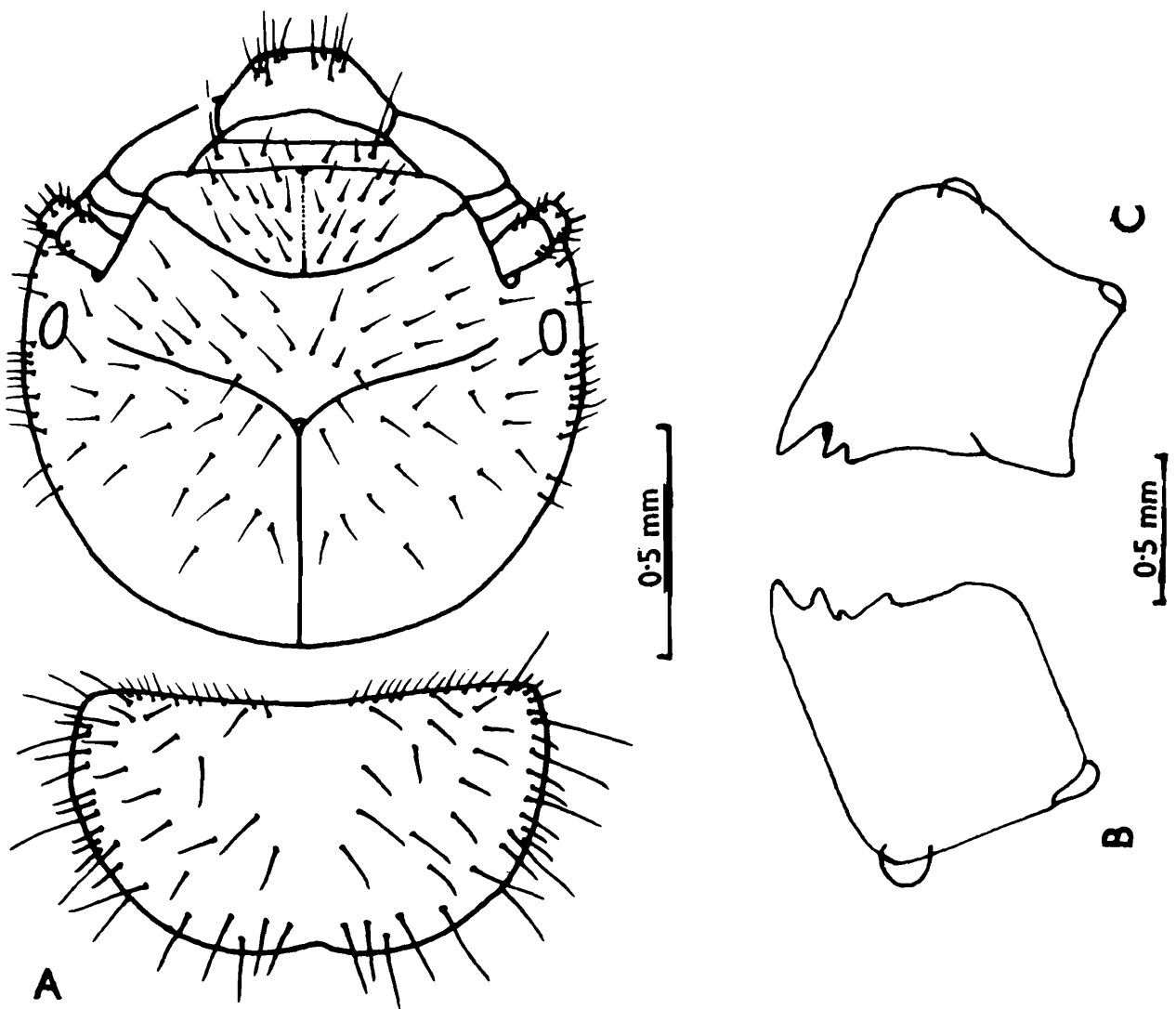

Fig. 292. *Stylotermes beesoni*. Worker. (A) Head and pronotum, in dorsal view. (B) and (C) Left and right mandibles (Redrawn from Sen-Sarma and Thakur 1979.)

Antennae with 13-14 segments; segment 2 subequal to 3 and 4 combined; 4 shortest. Postclypeus slightly swollen, subtrapezoidal; with an indistinct median line. Anteclypeus narrow, trapezoidal. Labrum broader than long; with rounded anterior margin. Mandibles as in genus. Pronotum flat, broader than long (width 0.85-0.93, length 0.48-0.55 mm); anterior margin weakly concave; posterior margin with a distinct median notch. Legs and abdomen as in soldier.

*Distribution* : INDIA : Tiliamura (Tripura, eastern India).

**90. *Stylotermes bengalensis* Mathur and Chhotani**  
(Figs. 286, 293-295)

*Stylotermes bengalensis* Roonwal and Chhotani:

1959. Mathur and Chhotani, *Zool. Anz.*, **163** (1&2) : 42-53. S and W. Holotype : S, in FRI, Dehra Dun. Type-locality : "Darjeeling Division", West Bengal, India. Types examined.
1962. Mathur and Thapa, *J. Timber Dry. Presser. Assoc. India*, **8**(4) : 8.
1970. Roonwal, In *Biology of Termites* (Eds. Krishna and Weesner) Vol. 2 : 335.
1974. Thakur, *Indian Forester*, **100** (11) : 692-695.
1975. Sen-Sarma et al. *Wood Destroying Termites of India* (Final Tech. Rept. PL 480 Prog.): 11, 37, 52, 64.
1975. Thakur, *J. Indian Acad. Wood Sci.*, **6** : 98.
1976. Gupta, *Indian Forester*, **102** : 254.
1980. Sen-Sarma and Thakur, *Indian For. Rec. (N.S.) Ent.*, **14**(1) : 8-9.
1982. Thapa, *Sabah For. Rec.*, No. 12 : 70.
1983. Maiti, *Occ. Pap. Rec. zool. Surv. India*, No. 42 : 55-56.
1983. Chhotani, *Oriental Insects*, **17**; 120.

**IMAGO DEALATE (Fig. 293) :** Head-capsule, pronotum, wing-scales and labrum bright yellowish brown; antennae, mesonotum and legs yellowish to pale brown; abdomen castaneous brown. Head-capsule moderately and body densely hairy with long hairs. Total body-length without wings 6.25-9.35 mm. Head-capsule subrectangular, wider than long (length 1.33-1.60, width with eyes 1.68-1.80 mm); sides (excluding eyes) subparallel upto posterior one-third; posterior margin broadly rounded; epicranial suture visible only in posterior part of head, lateral arms indistinct. Fontanelle not distinct. Antennae with 16 segments; segment 1 largest, 2 variable subequal to 3 and 4 or longer than 3, 3-5 ring like, 4 shortest. Eyes black, subcircular (maximum diameter 0.45-0.50, minimum diameter 0.40-0.45 mm). Ocelli hyaline, small (maximum diameter 0.18-0.23, minimum diameter 0.13-0.15 mm), translucent; separated from eyes by half their long diameter. Postclypeus subtrapezoidal, pilose; indistinctly demarcated from and of same colour as frons, anterior margin substraight; anteclypeus whitish, hyaline apilose. Mandibles as in genus. Labrum dome-shaped, wider than long (width 0.50-0.58, length 0.45-0.50 mm); anterior margin substraight;

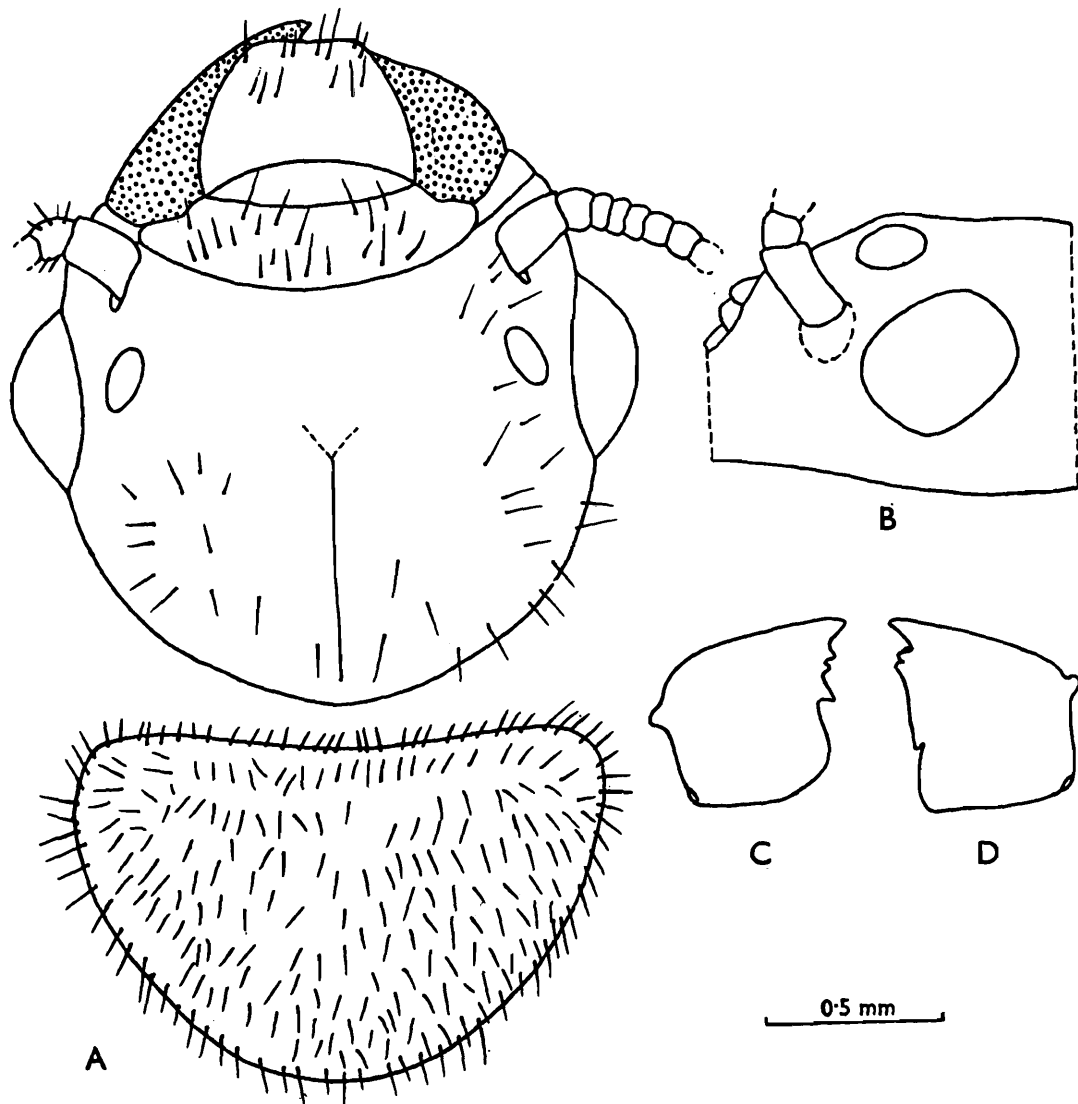

Fig. 293. *Stylotermes bengalensis*. Imago. (A) Head and pronotum, dorsal view. (B) part of head, side view showing eye and ocellus. (C) and (D). Left and right mandibles.

pilose anteriorly and on body. Pronotum subreniform, flat, densely pilose with long and short hairs; narrower than head with eyes and much broader than long (width 1.35-1.50, length 0.85-0.90 mm); anterior margin weakly concave, without notch; antero-lateral corners broadly rounded, sides converging to a rounded posterior margin. Legs long, densely pilose; femora swollen; tibiae slender, tibial spurs 3:2:2; tarsi 3-segmented. Abdomen densely hairy; cerci 2-segmented, hairy; styli absent.

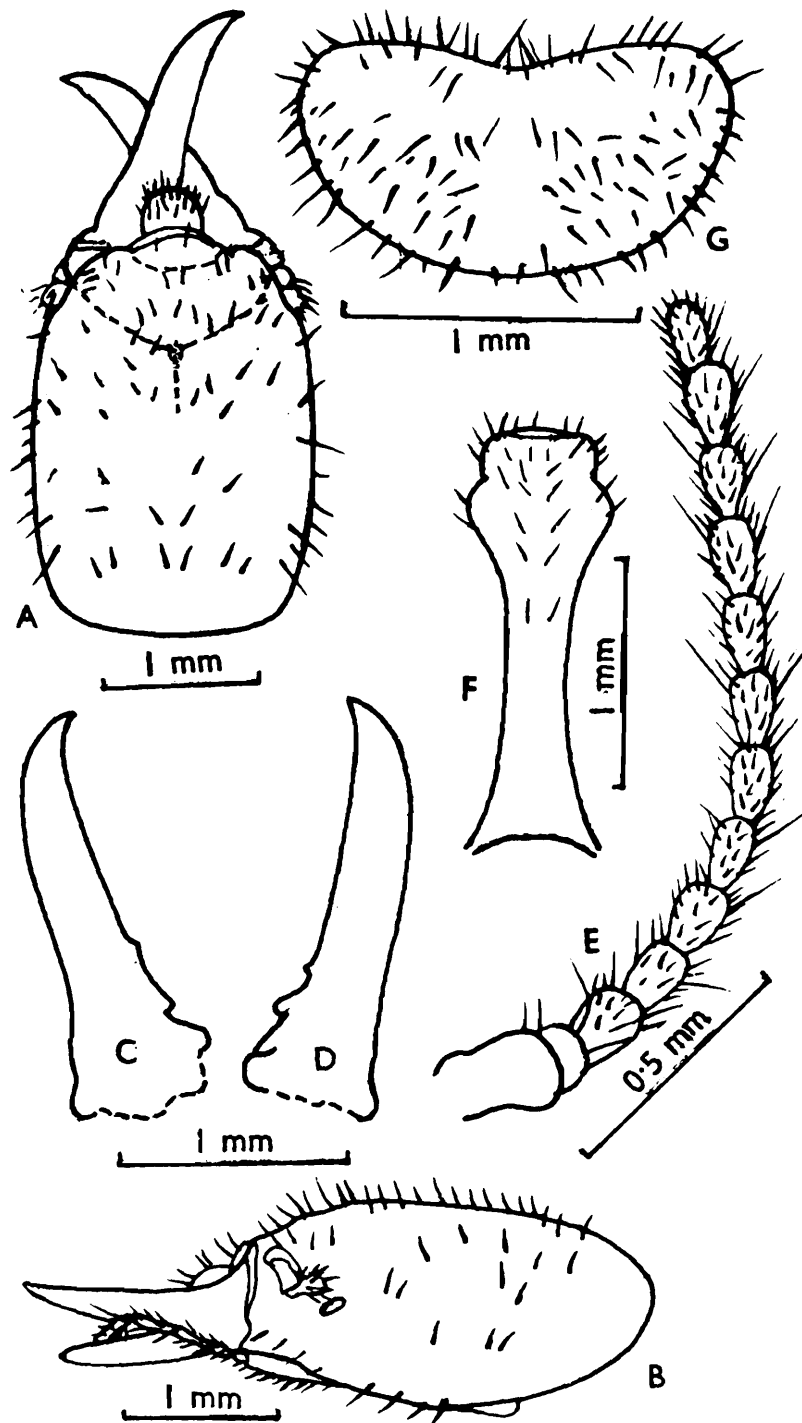

Fig. 294. *Stylotermes bengalensis*. Soldier. (A) Head, dorsal view. (B) Same, side view. (C) and (D) Left and Right mandibles. (E) Antenna. (F) Postmentum. (G) Pronotum, dorsal view. (Redrawn from Mathur and Chhotani 1959.)

**SOLDIER (Figs. 286, 294) :** Head brownish; rest paler. Head and thorax sparsely, and abdomen densely, hairy. Total length with mandibles c 8.0-8.8 mm. Head longish, subrectangular (with weakly convex sides), longer than broad (length 2.6-2.7, width 1.75-1.80 mm); epicranial suture weak. Fontanelle minute, circular, slightly raised; situated in distal one-third of head; small fontanelle gland visible. Labrum dome-shaped, broader than long, with several long hairs in distal half (length 0.25-0.30, width 0.45 mm). Anteclypeus narrow; postclypeus large. Mandibles stout, shorter than head (length 1.75-1.80 mm); with thick base, and slightly incurved pointed apex; inner margins with a weak tooth at proximal one-third and a larger one a little below. Eyes vestigial pale spots; in the types examined now, have become indistinct. Ocelli absent. Antennae with 13-14 segments; segment 2 smallest, 3 longer than 2 and 4. Postmentum long, club-shaped, with a long narrow waist in middle; club bilobed (length 1.80-2.00; max. width 0.70-0.75, width at waist 0.25 mm). Pronotum flat, narrower than head; length 0.80-0.90; width 1.45-1.55 mm; posterior margin rounded; anterior margin with a strong, and posterior one without median notch. Legs with femora stout, swollen; apical tibial spurs 3:2:2; tarsi 3-jointed. Abdomen elongate; cerci short, c. 0.15 mm. long, 2-jointed; styli absent.

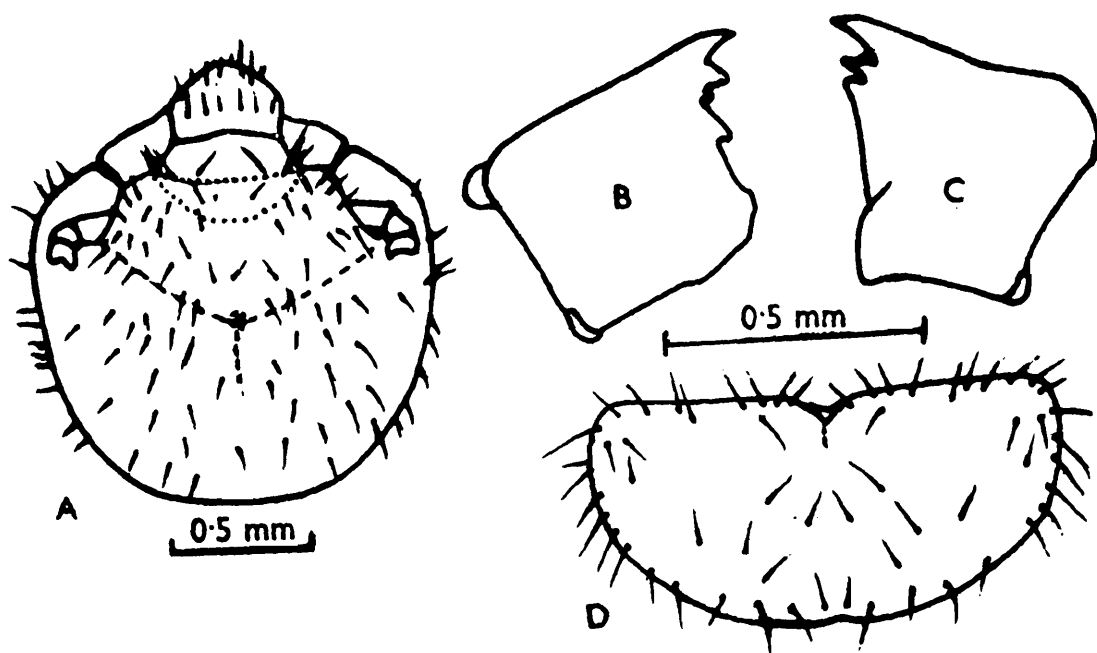

Fig. 295. *Stylotermes bengalensis*. Worker. (A) Head, dorsal view. (B) and (C) Left and Right mandibles. (D) Pronotum, dorsal view. (Redrawn from Mathur and Chhotani 1959.)

**WORKER (Fig. 295) :** Body yellowish, weakly hairy; length 4.7-6.1 mm. Head rounded, slightly narrowed posteriorly (length 1.00-1.12, width 1.15-1.50 mm). Fontanelle minute. Eyes vestigial. Ocelli absent. Labrum dome-shaped; length 0.38-0.50; width 0.40-0.45. Anteclypeus large; postclypeus weakly swollen, with median longitudinal suture indistinct. Mandibles of *Stylotermes*-type. Pronotum much broader than long; narrower than head (length 0.40-0.60, width 0.80-1.15 mm); anterior margin upturned, with a strong, median notch; posterior margin with a weak median notch. Legs and abdomen as in soldier.

*Distribution* : INDIA Sub-Himalayas : Kumaon Hills: Askot (Kanda Dhar Forest), Ranikhet and Bhowali (Almora Dist), Uttar Pradesh; Darjeeling Forest Division (West Bengal).

*Biology* : Found in dead and living wood of *Rhododendron* sp., *Morus laevigata*, *Quercus incana* and *Alnus nitida*.

### 91. *Stylotermes chakratensis* Mathur and Thapa (Figs. 296, 297)

*Stylotermes chakratensis* Mathur and Thapa :

1962. Mathur and Thapa, *J. Timber Dryers & Preserv. Assoc. India*, 8(4): 4-8. S and W.  
Holotype : S, in FRI. Type-locality : Koawa Block, Chakrata Forest Division (Dehra Dun Dist, Uttar Pradesh, India), c 6000 ft (c 1830 m) (Types examined.)

1970. Roonwal, In *Biol. of Termites* (Eds. Krishna and Weesner) Vol. 2: 355.

1975. Roonwal, *Biol. Zentralbl.*, 94: 28.

1975. Emerson, *Am. Mus. Novit.*, No. 2570: 13.

1982. Thapa, *Sabah For. Rec.*, No. 12: 70.

1983. Chhotani, *Oriental Insects*, 17: 120.

**IMAGO : Unknown.**

**SOLDIER (Fig. 296) :** Head reddish brown, rest yellowish. Head and body moderately hairy with short\*, stiff hairs. Total length 9.9-10.5 mm. Head longish, subrectangular, slightly narrowing anteriorly; longer than broad (length to base of mandibles 3.10-3.30, width 2.25-2.32 mm); frons gently sloping distally. Fontanelle minute, circular; situated in distal one-

---

\*Mathur and Thapa (1962b) describe these hairs as 'long'; actually they are minute on the head and somewhat longer on the body.

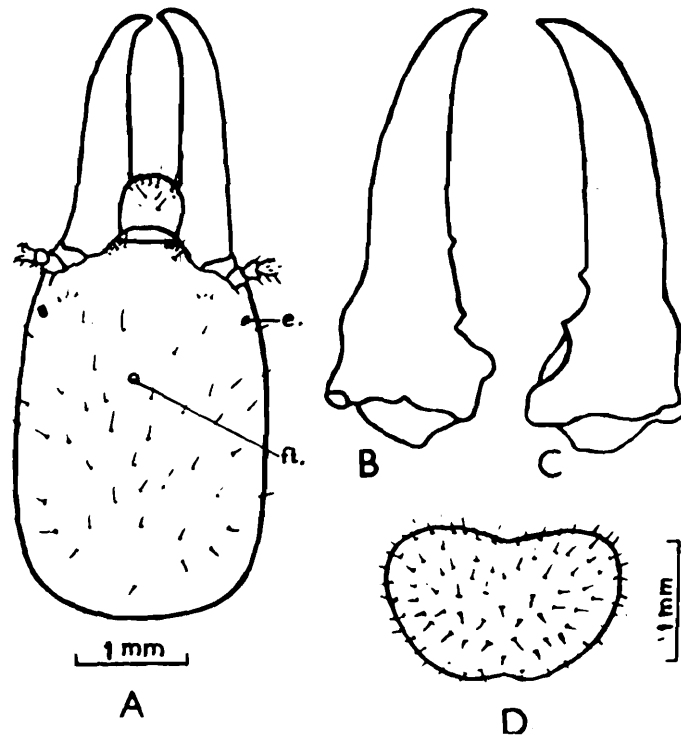

Fig. 296. *Stylotermes chakratensis*. Soldier. (A) Head, dorsal view. (B) and (C) Left and Right mandibles. (D) Pronotum, dorsal view.

e., eye; ft., fontanelle.

third of head, occipito-fontanelle distance 2.18 mm. Labrum subsquarish (length 0.50-0.54, width 0.55-0.67 mm); rounded distally, only slightly wider than long; with a few hairs in distal half. Anteclypeus narrow; postclypeus indistinctly demarcated from frons. Mandibles long (2.35-2.40 mm) and stout; slightly shorter than head; narrowing distally, with a pointed, weakly incurved apex; inner margin with a minute tooth in proximal one-third and a stronger one near base. Eyes vestigial, as small, dark spots. Ocelli absent. Antennae incomplete; segment 2 smaller than 3. Postmentum long, club-shaped, with a narrow longish waist; median length 2.37-2.50, maximum width 0.80-0.87, width at waist 0.30-0.35 mm; distal end clubbed; with anterior and posterior lobes, the latter only slightly broader than former. Pronotum flat, trapezoidal, narrower than head; width 1.92, length 1.25-1.30 mm; anterior and posterior margins with a median notch. Foreleg with robust femur and 3 apical tibial spurs; other legs damaged. Cerci short, 2-segmented; styli absent.

**WORKER** (Fig. 297) : Pale yellow; moderately hairy, with short stiff hairs. Total length 5.5-6.5 mm. Head rounded, length 1.5-1.6, width 1.67-1.80 mm; slightly narrowed posteriorly. Fontanelle small, situated in middle of head. Labrum dome-shaped, proximally narrower, with a few hairs in distal half. Eyes small and ocelli absent. Mandibles of *Stylotermes*-type. Antennae incomplete. Pronotum flat, narrower than head; length

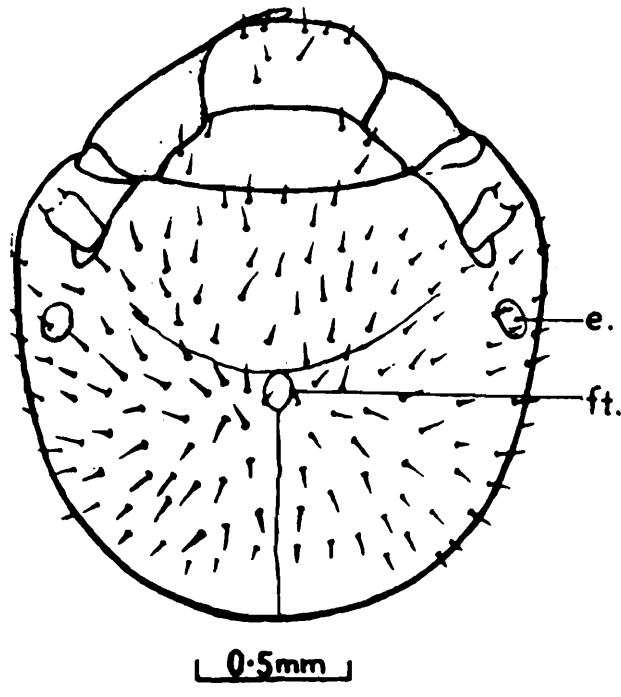

Fig. 297. *Stylotermes chakratensis*. Worker. Head, dorsal view.  
e., eye; ft., fontanella.

0.62-0.75, width 1.27-1.42 mm; anterior margin with a broad, and posterior-one with a small, median notch. Femora stout; apical tibial spurs 3:2:2. Cerci short, 2-jointed, styli absent.

*Distribution* : INDIA : North-Western Subhimalayas: Chakrata Forest Division (Dehra Dun District, Uttar Pradesh), c. 6000 ft (c 1830 m) altitude.

## 92. *Stylotermes dunensis* Thakur (Figs. 298, 299)

*Stylotermes dunensis* Thakur :

1975. Thakur, *J. Indian Acad. Wood Sci.*, 6(2): 98-105. Im, S, W. Holotype: S, in FRI, Dehra Dun. Type-locality : Dehra Dun (Uttar Pradesh, India). Paratypes examined.

1979. Roonwal, Verma and Thakur, *Proc. Indian natn. Sci. Acad.*, (B) 45(2): 124-125.

1979. Sen-Sarma et al., *Wood Destroying Termites of India* (Final Tech. Rep. PL 480 prog.): 11, 53, 64.

1981. Roonwal, *Proc. Indian natn. Sci. Acad.*, (B) 47(4): 471.

1983. Chhotani, *Oriental Insects*, 17: 120.

1983. Roonwal, *Proc. Indian natn. Sci. Acad.*, (B) 49(5): 370.

1985. Roonwal, *Proc. Indian natn. Sci. Acad.*, (B) 51(2): 154.

**IMAGO (Fig. 298) :** Head-capsule, pronotum, abdominal tergites and anterior margins of wings dark brown; antennae postclypeus, labrum and mandibles basally, yellow brown. Head fairly and body densely pilose. Total length with wings 9.4-10.7 mm. Head-capsule subsquarish (width 1.25-1.30, length to mandible-base 1.00-1.13 mm); sides subrounded; posterior margin broadly rounded; Y-suture not distinct. Fontanelle minute, rounded; situated a little posterior to middle of head; Eyes fairly large, black, subrounded (maximum diameter 0.33-0.45, minimum diameter 0.29-0.40 mm). Ocelli small, oval (maximum diameter 0.13-0.15, minimum diameter 0.08-0.10 mm); separated from eyes by a distance of 0.04-0.05 mm (half their short diameter). Antennae with 16-17 segments, segment 2 longer than 3, either 4 (16-segmented antennae) or 3 (17-segmented antennae) shortest. Postclypeus narrowly subrectangular (length

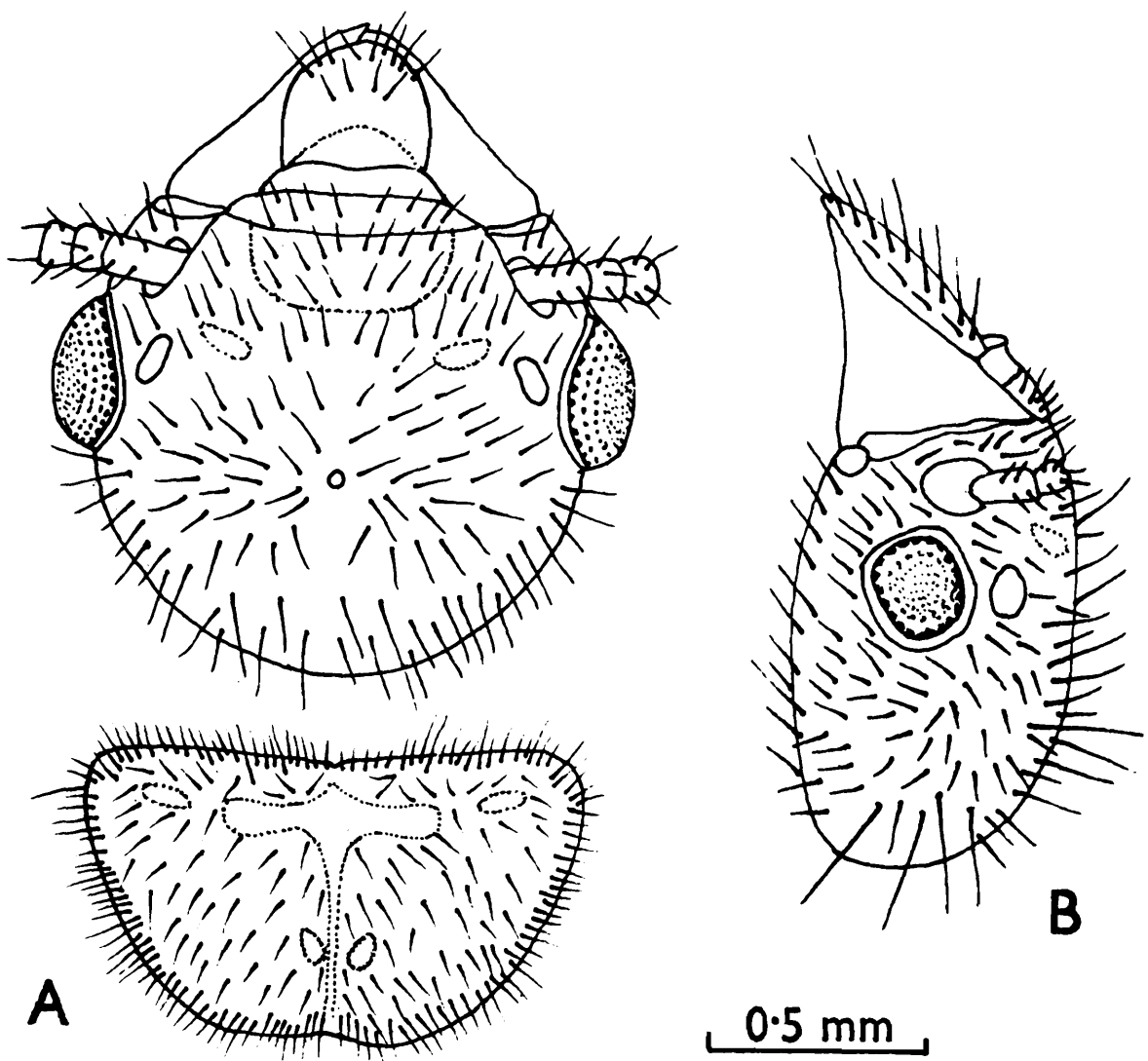

**Fig. 298.** *Stylotermes dunensis*. Imago (A) Head and pronotum, dorsal view, (B) Head, side view. (Redrawn from Thakur 1975.)

less than half of width) and with a few hairs; anteclypeus narrow, hyaline, apilose with anterior margin medially concave. Mandibles of *Stylotermes*-type. Pronotum flat, trapezoidal, much broader than long (width 0.95-1.00, length 0.50-0.60 mm); narrower than head-width with eyes; anterior margin substraight, with a median notch; posterior margin substraight with or without a median depression. Legs fairly long; femora swollen; tibiae slender, tibial spurs 3:2:2; tarsi 3-jointed. Wings hyaline, anterior margin dark. Forewings a little longer than hindwing, 8.00-9.10 mm long. Costa and radius thick, running close and parallel to each other. Media weak, unbranched; running medially; cubitus weak, giving off 19-21 branches. Hindwing as in forewing; media, however, arising from radius outside of wing scale. Abdomen oblong; cerci 2-segmented; styli absent.

**SOLDIER (Fig. 299) :** Head-capsule generally reddish brown, anterior part of head, antennae and mandibles basally, paler; labrum, pronotum and

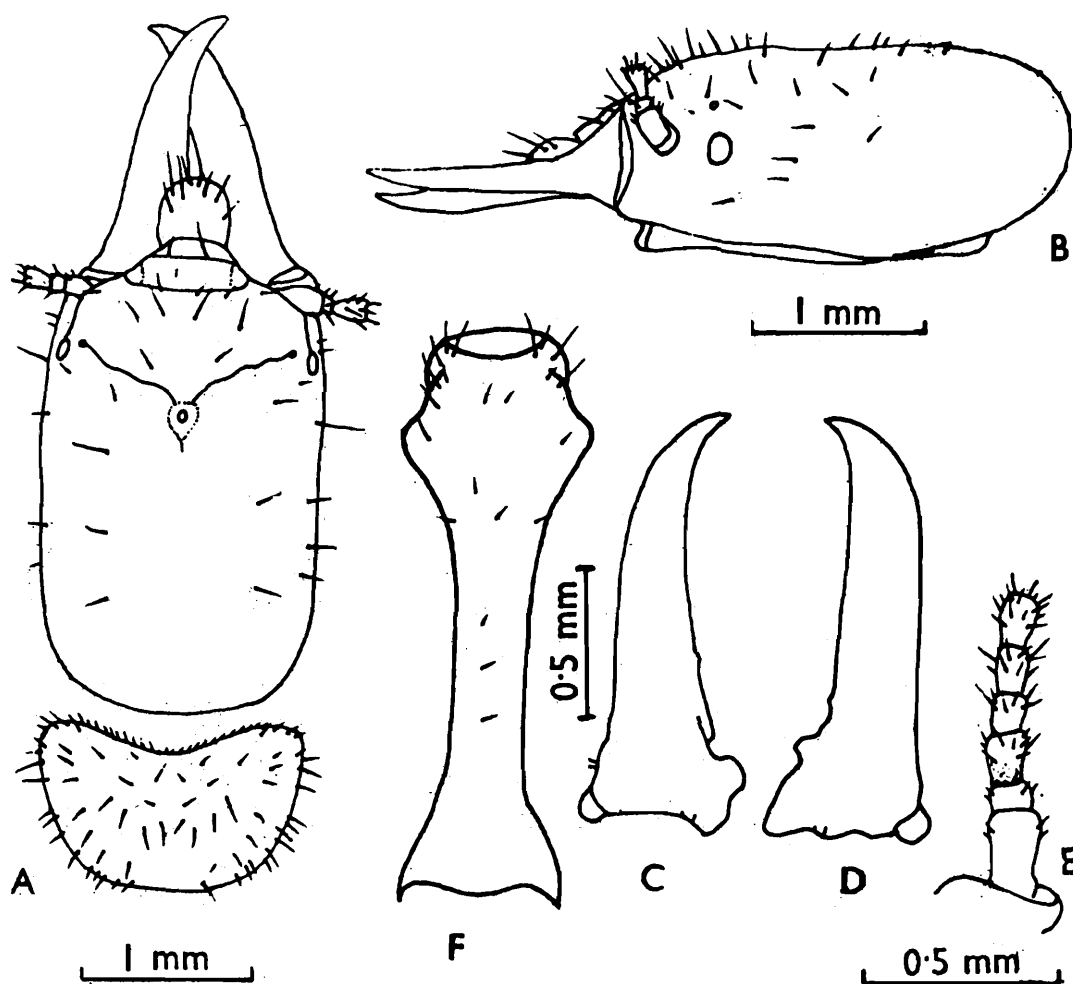

Fig. 299. *Stylotermes dunensis*. Soldier. (A) Head and pronotum, dorsal view. (B) Head, side view. (C) and (D) Left and right mandibles. (E) Antenna in part. (F) Postmentum.

legs yellowish brown; body yellowish. Head sparsely and body moderately pilose. Total length 6.55-7.50 mm. Head-capsule rectangular, much longer than broad (length to base of mandibles 2.15-2.45, width 1.40-1.55 mm), sides subparallel, converging a little posteriorly to a broadly rounded posterior margin; Y-suture with lateral arms visible, posterior arm indistinct. Fontanelle minute, situated at distal one-third of head. Eyes small, whitish, near antennal sockets. Ocelli minute, spot-like, separated from eyes by long diameter of eye. Antennae with 12-15 segments; segment 2 shortest; 3 longer than 4; 4, 5, 6 subequal. Postclypeus with a few hairs, subrectangular, not well differentiated from frons; anteclypeus whitish, apilose. Labrum dome-shaped, broader than long; with a few long hairs on body and on rounded anterior margin. Mandibles basally reddish brown, rest blackish; robust, sabre-shaped with weakly incurved apices, short (length 1.25-1.38 mm; Mandible/Head index 0.53-0.63). Left mandible with inner margin smooth and with only a minute crenulation at base. Right mandible also smooth on inner margin but with a basal, large, knob-like projection. Postmentum club-shaped, anterior part or club bilobed, broadest; posteriorly narrowed to a fairly long, slender waist (length 1.45-1.70, maximum width 0.48-0.60, width at waist 0.25-0.33 mm). Pronotum subtrapezoidal, broader than long (width 1.10-1.18, length 0.70-0.80 mm); a little narrower than head-width; anterior margin deeply concave with antero-lateral corners broadly rounded; sides converging posteriorly to a substraight posterior margin. Legs long, femora swollen, tibiae slender, tibial spurs 3:2:2; tarsi 3-jointed. Abdomen oblong; cerci 2-segmented.

**WORKER :** Head-capsule, antennae, postclypeus and labrum whitish yellow to yellow; pronotum paler; anteclypeus pale yellowish white; legs and abdomen whitish. Head-capsule sparsely and body fairly pilose. Total length 4.20-5.30 mm. Head capsule subrounded, a little broader than long (length to mandible-base 1.05-1.20, width 1.18-1.30 mm); Y-suture faintly visible. Fontanelle minute. Eyes oval, not very large, vestigial. Antennae with 14-15 segments; segment 4 shortest. Postclypeus weakly swollen, darker than frons; anterior margin concave; with a few hairs near margin and on body. Anteclypeus trapezoidal, apilose. Labrum dome-shaped, wider than long; anterior margin weakly convex, with a few hairs near margin and on body. Mandibles of *Stylotermes*-type. Pronotum trapezoidal, broader than long (width 0.90-1.05, length 0.55-0.65 mm); narrower than head; anterior margin concave, without median notch; posterior margin weakly convex with or without median notch. Legs and abdomen as in soldier.

*Distribution* : INDIA Dehra Dun (U.P., Western Himalayas), type-locality.

**93. *Stylotermes faveolus* (Chatterjee and Thakur)  
(Figs. 300, 301)**

1. *Sarvaritermes faveolus* Chatterjee and Thakur :

1963. Chatterjee and Thakur, *Indian Forester*, **89**(9): 635-637. *Nomen nudum*.

1964. Chatterjee and Thakur, *Zool. Anz.*, **173**(2): 149-162. Im, S and W. Holotype: S, in FRI. Type-locality: Sarvari Village, Notified Cremation Ground Area, near Kulu Saw Mills, Kulu Valley, Himachal Pradesh, India. Paratypes examined.

1970. Roonwal, In *Biol. of Termites* (Krishna and Weesner, Eds.) Vol. 2: 335.

1975. Emerson, *Am. Mus. Novit.*, No. 2570: 13. (Treats as synonym of *S. chakratensis*)

2. *Stylotermes faveolus* (Chatterjee and Thakur) :

1975. Roonwal, *Biol. Zentralbl.*, **94**: 28, 29.

1983. Chhotani, *Oriental Insects*, **17**: 120.

1986. Roonwal, Verma and Bisen, *Proc. Indian natn. Sci. Acad.*, (B) **52**(2): 242-244, 253.

**IMAGO (Fig. 300) :** Head and body brown\*; antennae, legs and lower part of thorax brownish yellow; postclypeus and labrum yellowish brown; wings transparent almost colourless\*. Head, body and legs densely pilose. Total length with wings 15.80-16.40 and without wings 8.60-9.10 mm. Head-capsule subrounded, a little broader than long (width with eyes 1.65-1.80, length to base of mandibles 1.40-1.55 mm); Y-suture present, lateral arms not so distinct. Fontanelle minute, situated in middle of head. Antennae with 20-22 segments; segment 2 variable, subequal to or longer than 3 or equal to 3 and 4 combined; from 5 increasing a little in length. Eyes large, blackish, subcircular (maximum diameter 0.40-0.45 mm); situated at a distance of 0.08 mm from antennae. Ocelli hyaline, whitish (maximum diameter 0.18-0.20 mm); minimum eye-ocellus distance less than half maximum diameter of ocellus, 0.08 mm. Postclypeus orange yellow with no median line present, trapezoidal, swollen; with a few setae-like hairs; length less than half width, anterior margin slightly concave. Anteclypeus whitish, apilose, subequal to postclypeus in length. Mandibles

---

\*In the original description, Chatterjee & Thakur (1964) have described the imagoes as dark castaneous brown and the wings as dark smoky grey. We have examined their entire material, including all the types. The imagoes are brown (almost pale brown) and the wings have no smoky tinge.

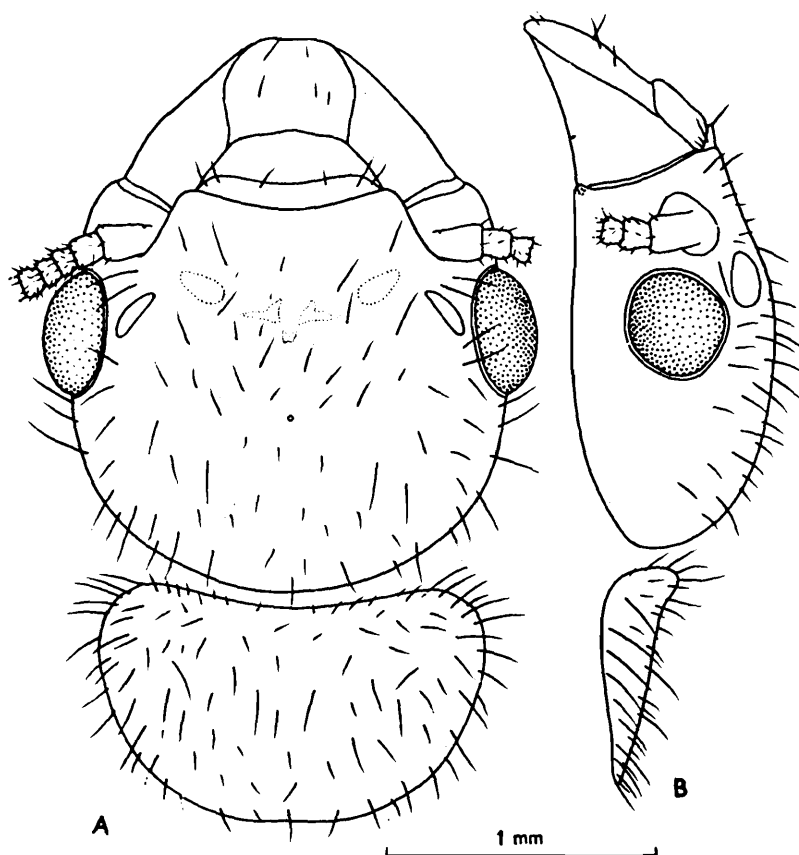

Fig. 300. *Stylotermes faveolus*. Imago. (A) Head and pronotum, dorsal view. (B) Same, side view.

as in genus. Pronotum flat, much broader than long (length 0.80-0.85, width 1.40-1.48 mm) and narrower than head-width with eyes; anterior margin concave, with weak median notch; posterior margin rounded, with weak median emargination. Legs with femora long and swollen; tibiae long and slender; tibial spurs 3:2:2; tarsi 3-jointed. Wings strongly reticulate. Forewing longer than hindwing, 13.00-13.70 mm long. Hindwing with scale 11.75-12.40 mm long. Venation as in genus; cubitus in forewing with 21-23 and in hindwing with 19-23, branches. Abdomen oblong, pilose; cerci 2-segmented; styli absent.

**SOLDIER (Fig. 301)** : Head-capsule and postclypeus reddish brown; mandibles basally dark brown, rest blackish; anteclypeus whitish; antennae and labrum pale brownish; pronotum brownish yellow; legs and abdomen yellow. Head and body fairly densely pilose. Total length 10.00-13.50 mm. Head-capsule subrectangular, much longer than broad (length to base of mandibles 3.20-3.70, width 2.30-2.60 mm); sides slightly converging in front; posterior margin rounded. Fontanelle oval, small; situated a little

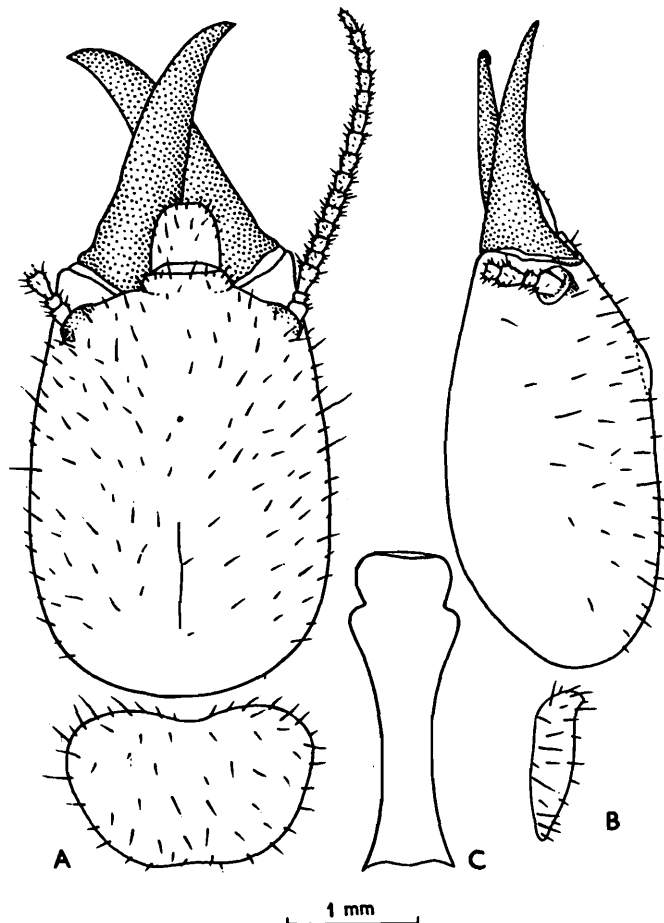

Fig. 301. *Stylotermes faveolus*. Soldier. (A) Head and pronotum, dorsal view. (B) Same, in side view. (C) Postmentum.

anterior to middle of head. Antennae with 16-19 segments; segment 2 shortest, 3 fairly long, 4 and 5 subequal and 6 onwards increasing in length. Eyes small, vestigial, close to antennae. Ocelli absent. Postclypeus broad, not clearly differentiated from frons, length about half of width; anterior margin convexical, sparsely pilose; anteclypeus whitish, narrow, apilose. Labrum rounded, dome-shaped; length 0.35-0.48, width 0.55-0.63 mm; with a few hairs on anterior margin and on body. Mandibles long (2.00-2.30 mm), robust, sabre-shaped and incurved apically; inner margins smooth except for a few crenulations. Left mandible with a crenulation below middle. Right mandible with a small crenulation at upper part of proximal one-third and a larger tooth like projection at base of mandible. Postmentum long, club-shaped, postmentum length 2.45-2.70 mm; club divided into an anterior and a broader posterior part (maximum width 0.85-1.00 mm); narrowing posteriorly to a waist with minimum width (0.30-0.40 mm) a little above middle and again widening out at base. Pronotum pilose, flat, trapezoidal; much broader than long (width 1.75-2.10 length 1.15-1.35 mm); anterior margin with a deep median notch; sides

curving round to a medially emarginate posterior margin. Legs with femora stout and swollen; tibiae long, slender; tibial spur 3:2:2; tarsi 3-jointed. Abdomen oblong; cerci 2-segmented; styli absent.

**WORKER** : Head-capsule and postclypeus yellowish, frons paler; labrum yellow to brownish yellow; antennae and legs paler than head; body creamy white. Head fairly and body densely pilose. Total length 7.50-9.00 mm. Head-capsule subrounded, widest anteriorly (length to mandible base 1.55-1.85, width 1.7-2.0 mm) posteriorly rounded; Y-suture indistinct. Eyes and ocelli not visible. Antennae with 17-20 segments, segment 4 shortest. Postclypeus broad, weakly swollen; with a few hairs; anteriorly concave, posteriorly convex. Anteclypeus whitish, apilose, trapezoidal. Labrum and mandibles as in imago. Pronotum flat, broader than long (width 1.40-1.65, length 0.63-0.95 mm); anterior margin a little upturned, concave; posterior margin convex and medially notched. Legs and abdomen as in soldier.

*Distribution* : INDIA : Himachal Pradesh: Kulu Valley (c 1190-1280 m altitude)

*Biology* : It attacks living and partly dead trees of Kash (*Alnus nitida*), making longitudinal galleries. Small colonies are found scattered in irregular chambers in wood which contain eggs, nymphs and other castes; swarming occurs (in the laboratory) in July (Chatterjee and Thakur, 1963; Roonwal 1970a, p. 335).

#### 94. *Stylotermes fletcheri* Holmgren and Holmgren (Figs. 287, 302-304)

*Stylotermes fletcheri* Holmgren and Holmgren:

1917. Holmgren and Holmgren, *Mem. Dept. Agric. India (Ent.)*, 5(3) : 142-144. Im, S, W, Ny and larvae. Holotype : Not designated. Syntypes in ZSI, Calcutta (Im, Ny); FRI, Dehra Dun (Im, Ny); AMNH, New York (Im, S, W, Ny) and also probably in Holmgren Coll., National Museum, Stockholm. Type-locality : Coimbatore (Tamil Nadu, India). Types examined.

1919. Fletcher, *Proc. 3rd ent. Mtg. Pusa*, 1 : 314.

1921. Fletcher, *Bull. Dept. Agric. India*, No. 100 : 246.

1934. Margabandhu, *J. Bombay nat. Hist. Soc.*, 37(3) : 704.

1949. Snyder, *Smiths. misc. Colls.*, 112 : 75.

1953. Ratan Lal & Menon, *Catal. Indian Ins., Pt. 27, Isoptera*: 33. (authorship assigned to Holmgren erroneously).
1959. Mathur and Chhotani, *Zool. Anz.*, 163(1&2) : 40, 41, 46-53. Im, S, W.
1970. Roonwal, In *Biol. of Termites* (Eds. Krishna & Weesner) Vol. 2 : 335.
1974. Thakur, *Indian Forester*, 100(11) : 693.
1975. Roonwal, *Biol. Zentralbl.*, 94 : 28, 29.
1981. Roonwal, *Proc. Indian natn. Sci. Acad.*, (B) 47 (4) : 471.
1983. Chhotani, *Oriental Insects*, 17 : 120.
1984. Bose, *Occ. Pap. Rec. Zool. Surv. India*, No. 49 : 75-77.
1986. Roonwal, Verma and Bisen, *Proc. Indian natn. Sci. Acad.*, (B)52(2) : 244.

**IMAGO (Figs. 302, 303):** Head pale to dark brown, rest paler. Head and body moderately hairy, with short and long hairs. Total length with wings 12.0-13.50, without wings 7.0-7.6 mm. Head subcircular; length to base of mandibles 1.18-1.24, width 1.45-1.55 mm. Epicranial suture absent. Fontanelle minute. Eyes well developed, round, black; max. diameter 0.40-0.43 mm. Ocelli whitish, oval, separated from eyes by about half the maximum diameter of ocelli; max. diameter 0.16-0.20 mm. Labrum dome-shaped, with a few hairs. Postclypeus slightly longer than anteclypeus; swollen, and with a median longitudinal suture. Mandibles of typical *Stylotermes*-type. Antennae with 18-19 segments; segment 2 longer than 3 and subequal to 4. Pronotum flat, trapezoidal, with rounded corners; narrowed posteriorly; narrower than head; broader than long (length 0.70-0.80\*; width 1.18-1.29 mm); anterior and posterior margins each with a weak median notch. Femora and tibia long and slender; apical tibial spurs 3:2:2; tarsi 3-segmented. Wings hyaline, with a reticulum of numerous fine cross-veins. Forewing 9.95-10.80 mm long. Scale larger than in hindwing; costa thick; radius thick, running parallel to costa; media, arising inside scale, thin, unbranched; cubitus also arising inside scale, with 21-22 branches. Hindwing 9.50-10.40 mm long. Scale small; costa and radius as in forewing; media arising from radial sector just outside scale, sometimes with 1-2 branches; cubitus with 20-21 branches. Abdomen with cerci short, 2-jointed; styli absent.

---

\*Holmgren & Holmgren (1917) gave the length of pronotum as 1.05 mm., which is evidently an error (as also remarked by Mathur and Chhotani 1959, p. 48).

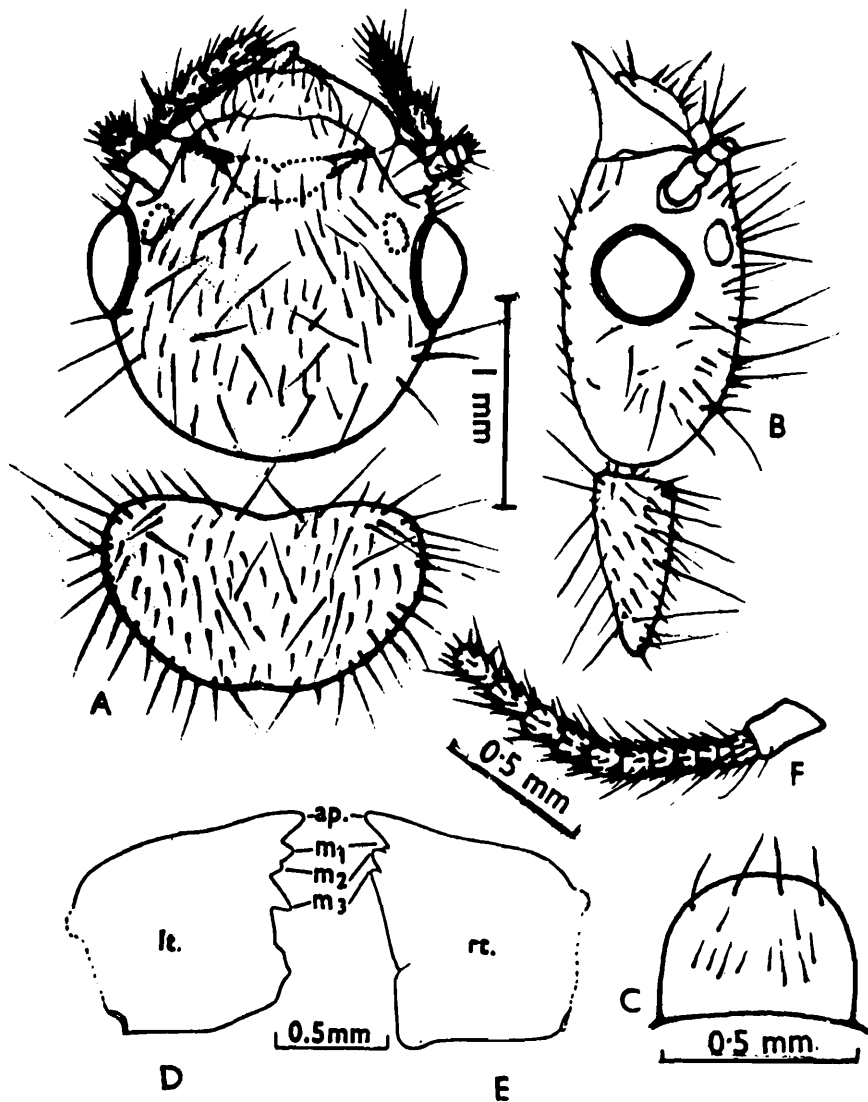

Fig. 302. *Stylotermes fletcheri*. Imago. (A) Head and pronotum, in dorsal view. (B) Same, in side view. (C) Labrum. (D) and (E) Left and right mandibles. (F) Antenna, basal part.

ap., apical tooth;  $m_1$ ,  $m_2$  and  $m_3$ , 1st, 2nd and 3rd marginal teeth. (Redrawn from Mathur and Chhotani 1959.)

**SOLDIER (Fig. 304):** Head brownish yellow, rest paler, Head and body sparsely hairy. Total length with mandibles c 8.0-8.80 mm. Head longish, subrectangular; length to base of mandibles 2.35-2.66, max. width 1.65-1.73 mm. Fontanelle minute, circular; situated in anterior one-third of head; with a small gland; occipito-fontanelle distance 1.70 mm. Labrum broad, tongue-shaped, a little wider than long (length 0.40, width 0.45 mm); with a few long hairs distally. Anteclypeus narrow; postclypeus longer, not sharply

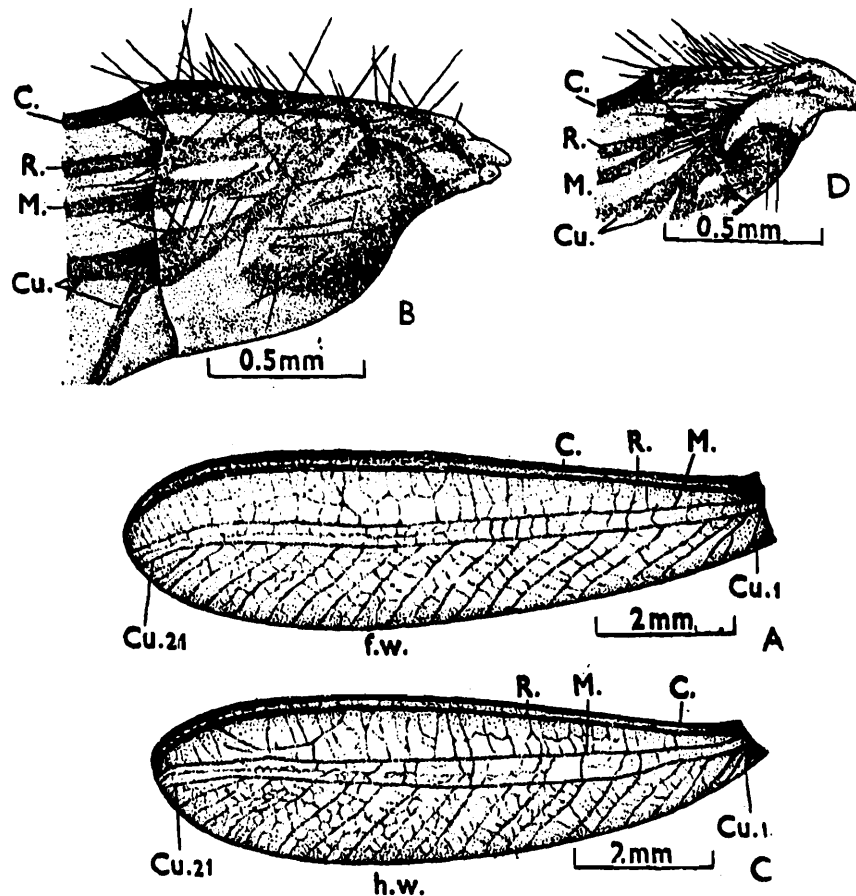

Fig. 303. *Stylotermes fletcheri*. Wings. (A) Left forewing without scale. (B) Same, scale enlarged to show origin of veins. (C) Left hindwing without scale. (D) Same, scale enlarged to show origin of veins.

C., costa; Cu., cubitus (1-21 branches); f.w., forewing; h.w., hindwing; M., media; R., radius. (After Mathur and Chhotani 1959.)

separated from frons. Mandibles long, thick throughout (length 1.80 mm); slightly narrowing distally, pointed and slightly incurved at apex; about 3/4 of head-length (index Mandible-length Head-length 0.72); inner margins with a minute tooth in posterior one-third and a larger one near base. Antennae with 14-15 segments; segment 2 short, 3 longer than 2 and 4. Postmentum long, club-shaped, broad anteriorly; waist long, situated in middle, and with subparallel sides; length 2.00, max. width 0.65, width at waist 0.25 mm. Pronotum flat, trapezoidal (length 0.85-1.00, width 1.43-1.50 mm); broader than long; anterior margin well angulated with a marked median notch; posterior one with a weak, median notch. Abdomen hairy. Cerci small, c 0.15 mm long, 2-jointed; styli absent.

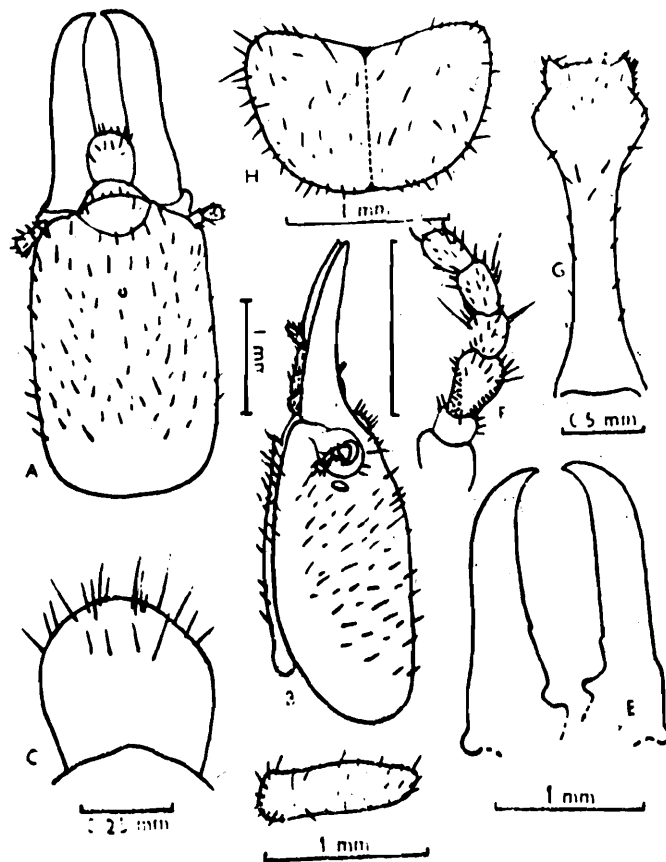

Fig. 304. *Stylotermes fletcheri*. Soldier. (A) Head, dorsal view. (B) Same, side view. (C) Labrum. (D) and (E) Left and right mandibles. (F) Antenna, basal six segments. (G) Postmentum. (H) Pronotum, dorsal view. (I) Same, side view. (Redrawn from Mathur and Chhotani 1959).

**WORKER:** Pale yellowish; moderately hairy, hairs on abdominal tergites in two irregular rows. Total length 4.6-6.0 mm. Head subcircular; length to base of mandibles 0.95-1.25, width 1.15-1.35 mm. Fontanelle minute. Eyes small, vestigial. Ocelli absent. Labrum, clypeus and mandibles as in imago. Antennae with 15-16 segments; segment 2 longer than 3. Pronotum flat, narrower than head, trapezoidal; with rounded angles; length 0.43-0.65, width 0.85-1.13 mm. Mesonotum with a short and metanotum with a long, pleural process on either side (see note below). Legs long and thin; apical tibial spurs 3:2:2; tarsi 3-segmented. Cerci short; styli absent.

*Note on pleural processes on meso- and metanota in workers, larvae and nymphs:* Holmgren and Holmgren (1917, p.143) state: "Pleura of meso- and meta-notum each with a pair of stumpy, stout, posteriorly-directed processes, those on the mesonotum very short, those on the metanotum almost as long as the femora" They also mention the existence of these

processes in nymphs and larvae. For nymphs they state: "with long wing sheaths and *below these with small processes* as in the workers" For larvae they state: "The meso-and meta-thorax with very distinct lateral processes. Those of the mesonotum are conical, those of the metanotum are bent into a knee-shape (jointed) with a stouter basal joint and a slenderer apical joint. Apical joint slightly incurved" These authors state further (p. 144) that while these processes may recall wing-stumps, they have nothing to do with them; they are pleural outgrowths and are present in the nymphs together with wing sheaths, and are probably "analogous to the posteriorly-directed processes which have been mistaken for" wing-stumps "in young larvae of *Calotermes rugosus* and *Glyptotermes dilatatus*".

Mathur and Chhotani (1959, p. 50), who redescribed *S. fletcheri* from the cotype material, make no mention of these pleural process. We have examined the workers in the F.R.I. syntype material and confirm the existence of these processes.

These processes have not been found in any of the other species.

*Distribution* : INDIA : Tamil Nadu: Coimbatore and Shevaroy Hills, upto c 1220 m altitude. Karnataka : Chickmagalur.

*Biology* : Attacks mango, *Mangifera indica* and other trees, tunneling in dead portions of trees. The nest extends to living portion also. The galleries are longitudinal, filled with damp, blackish faecal matter. The winged forms have been collected during October-November from the nests.

### 95. *Stylotermes parabengalensis* Maiti

(Fig. 305)

*Stylotermes parabengalensis* Maiti:

1974. Maiti, *Oriental Insects*, 9(2) : 143-148. S. Holotype : S, in ZSI, Calcutta.

Type-locality : Near Nagrakata Rly. Station, Jalpaiguri Dist., West Bengal, India.

1983. Maiti, *Occ. Pap. Rec. zool. Surv. India*, No. 42 : 22, 56.

1983. Chhotani, *Oriental Insects*, 17 : 120.

IMAGO : Unknown.

SOLDIER (Fig. 305): Head-capsule brownish yellow, paler posteriorly; antennae, labrum and pronotum pale brownish; mandibles blackish, dark

brown basally; abdomen and legs whitish yellow. Head and pronotum fairly and body densely hairy. Total length 5.8-6.35 mm. Head-capsule subrectangular, longer than wide (length to base of mandibles 1.92-2.23, width 1.19-1.34 mm); sides substraight, weakly narrowed in front; frons sloping anteriorly; Y-suture faint. Fontanelle minute, slightly raised and situated a little behind the junction of epicranial sutures. Eyes whitish, faint 0.10-0.14 mm long. Ocelli indistinct. Antennae with 12-13 segments; segment 2 small; 3rd large and sclerotic, more than double the length of 2; 4

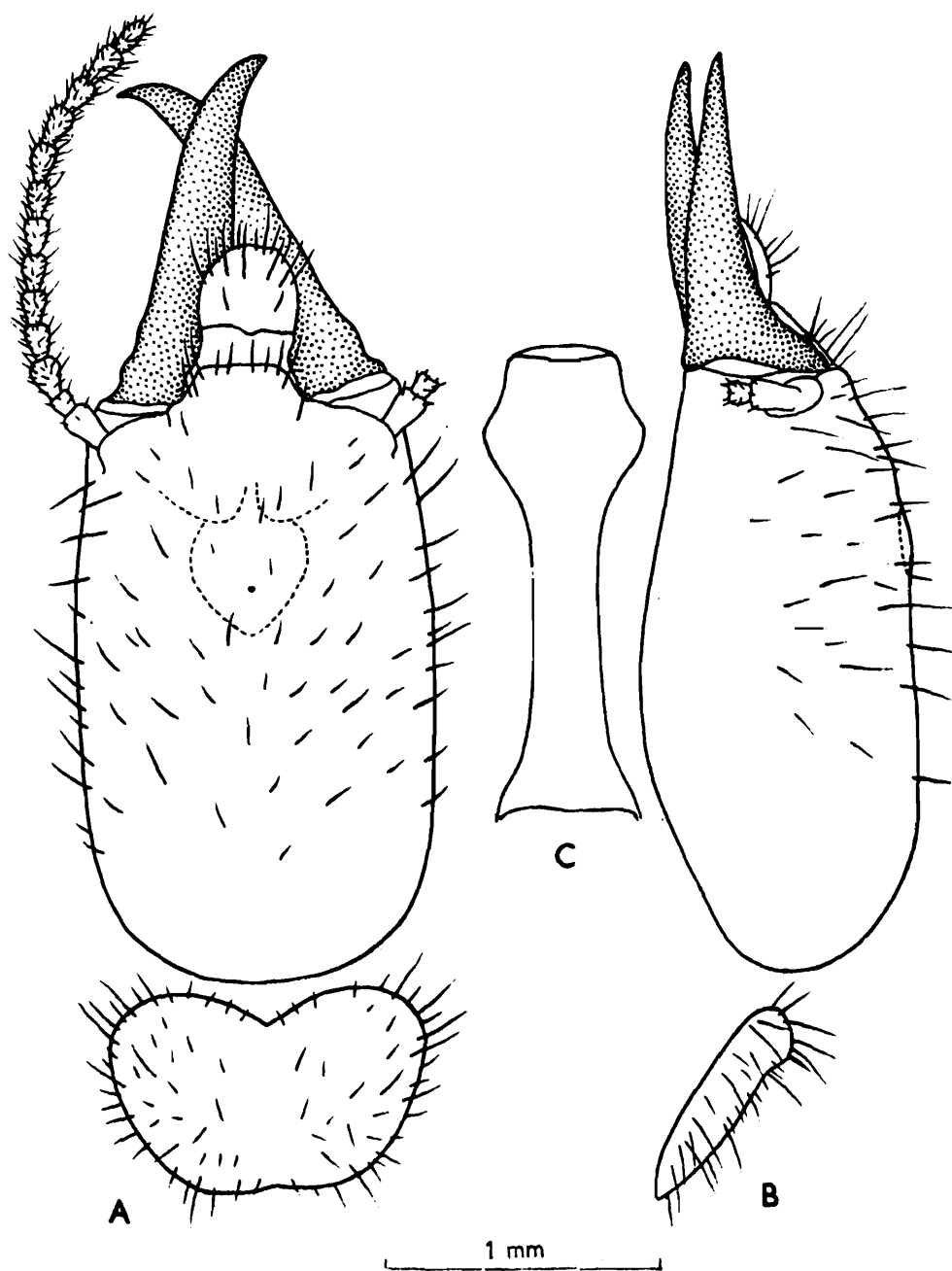

Fig. 305. *Stylotermes parabengalensis*. Soldier. (A) Head and pronotum, dorsal view. (B) Same, side view. (C) Postmentum.

smaller than 3. Postclypeus indistinctly demarcated from frons, pilose; anteclypeus apilose, hyaline strip. Labrum slightly broader than long; rounded anteriorly (length 0.30-0.34, width 0.34-0.38 mm). Mandibles sabre-shaped, weakly incurved apically, less than 2/3rds of head-length (length 1.14-1.26, index Mandible-length/Head-length to base of mandibles 0.55-0.59). Mandibles without any distinct teeth, left with a few weak crenulations basally. Postmentum club-shaped, with a long waist (length 1.34-1.61, max. width 0.46-0.57, min. width 0.17-0.23 mm; contraction index 0.37-0.43). Pronotum flat, narrower than head and subtrapezoidal (length 0.61-0.76, width 1.0-1.13 mm); anterior margin convexical and deeply notched medially; antero-lateral corners narrow; lateral margins strongly converging posteriorly; posterior margin weakly emarginate medially. Legs with 3:2:2 apical tibial spurs and 3-jointed tarsi. Abdomen elongate, hairy; cerci 2-jointed; styli absent.

**WORKER:** Head-capsule straw yellow; body, antennae and legs whitish. Total body-length 3.9-5.5 mm. Head-capsule subcircular (length to base of mandibles 0.94-1.14, width 1.0-1.23 mm); Y-suture present. Eyes small subcircular. Antennae with 14 segments. Labrum broader than long, rounded anteriorly. Postclypeus slightly swollen, with a median groove. Mandibles typically *Stylotermes*-type. Pronotum flat, slightly less than twice as wide as long (length 0.50-0.60, width 0.80-1.00 mm); anterior margin deeply notched medially. Legs and abdomen as in soldier.

**Distribution :** INDIA : West Bengal Near Nagrakata Railway Station, Dist. Jalpaiguri (type-locality) and Kalabagan Gorokhathan, Cooch Behar, Dist. Cooch Behar.

#### Family VI. INDOTERMITIDAE Roonwal and Sen-Sarma

##### 1. Fam Indotermitidae:

1958. Roonwal and Sen-Sarma, In Roonwal. *Trans. Bose Res. Inst.*, 22 : 81-82.

1960. Roonwal and Sen-Sarma, *Contrib. Syst. Oriental Termites* (ICAR Ent. Monogr. No.1) 40-42.

1962. Roonwal, *Termites in Humid Tropics*, : 35.

1969. Pruthi, *Textb. Agric. Ent.* (ICAR), p. 371.

1970. Roonwal, In *Biol. of Termites* (Ed. by Krishna and Weesner), Vol. 2 : 317, 384.

1975. Roonwal, *Biol. Zbl.*, 94(1) : 32.

1986. Roonwal and Chhotani, *Rec. zool. Surv. India*, **83**(3&4) : 155.

2. Genus *Indotermes* R. and S. (Fam. Termitidae, Amitermitinae/Apicotermitinae) :

1963. Ahmad, *Annals Mag. nat. Hist.*, (13) **6** : 395.

1965. Krishna, *Amer. Mus. Novitat.*, No. 2210:3.

1970. Krishna, In *Biol. of Termites* (Ed. by Krishna and Weesner), Vol. 2 : 141.

1970. Weidner, *Handb. d. Zool.*, Vol. 4 (Arthropoda), Sec. 2 (Insecta), Pt. 2 (Special), Liefer. 13, No.14 (Isoptera): 23-24.

1975. Akhtar, *Bull. Dept. Zool. Univ. Panjab* (Lahore) (N.S.), Art. 7 : 112-120. (Apicotermitinae).

Type genus : *Indotermes* Roonwal and Sen-Sarma (syn. *Sinotermes* He. and Xia). South and south-east Asia Bhutan, N.E. India, Bangladesh, Burma, Thailand and S. China.

### 1. *Characters of Family Indotermitidae*

*Imàgo* : Head and body densely pilose. Head hypognathus; mid-dorsal spot present; Y-suture faint. Eyes large, bulging. Ocelli small, oval, not widely separated from eyes. Antennae with 15 segments. Mandibles with an apical and 2 marginal teeth; the second marginal relatively small. Pronotum weakly saddle-shaped, the sides narrowing posteriorly. Legs with 3-segmented tarsi; apical tibial spur formula 2:2:2. Wings colourless, transparent; with few hairs on membrane; margins more hairy, hairs small; veins faint except the 2 long anterior ones. Forewing scale larger than hindwing scale. Forewing: Length 13-16, width 3.3 mm. Costa long, thick, well chitinised; subcosta short, joining costa just outside scale; radius long, thick, running close to and parallel to media arising independently and with 3-4 branches; cubitus with 8-12 branches. Hindwing: Length 12.0-14.5 mm; width 3.5 mm. Costa and radius as in forewing; subcosta absent; media arising from radius and with 3-4 branches; cubitus with 10-12 branches. Wing microsculpturing present on both surfaces and consists of papillae and micrasters. Papillae minute, pointed, 1-3  $\mu$ m long, present in a single row on anterior margin. Micrasters minute 1-6  $\mu$ m long, simple and non-asteroid, with 1-3 arms, mostly rod-like, present all over the membrane, density 3100-3600/mm<sup>2</sup> (Roonwal and Rathore, 1986). Cerci short, 2-segmented; styli absent.

**Soldier** Head and body profusely hairy, with numerous small hairs and a few longer bristles. Head massive, subsquarish; strongly hypognathus; Y-suture and mid-dorsal spot apparently absent. Eyes and ocelli absent. Labrum very small (in relation to the massive head), dome-shaped to tongue-shaped in outline, with subparallel sides; with many small hairs on body and some long bristles at the margins. Antennae long, slender, with 14-15 segments, mostly 14; segment 2 shortest. Mandibles thick, massive, about two-thirds the head-length; with a large, plate-like basal area and a small, incurved, attenuated, pointed apical part; the two separated by a large forwardly directed pointed tooth. Postmentum strongly hairy, long with a marked bulge in anterior third; anterior margin substraight, posterior margin substraight to incurved. Pronotum much smaller than head, strongly saddle-shaped, the anterior lobe narrower and much longer than the posterior; sides narrowing posteriorly; anterior margin weakly to strongly convex; posterior margin substraight to convex, with or without a weak median notch. Meso- and metanota small. Legs long, slender, femora slightly swollen. Tarsi 3-segmented; apical tibial spur formula 2:2:2; empodium absent. Cerci short, 2-segmented; styli absent.

**Worker** : Head and body moderately pilose. Head suboval, hypognathus. Y-suture and mid-dorsal spot present. Labrum dome-shaped, bulging in anterior third. Eyes and ocelli absent. Mandibles with an apical and 2 marginal teeth; second marginal small. Antennae with 14 segments. Pronotum narrower than head, strongly saddle-shaped, anterior lobe longer than the posterior; sides strongly narrowing posteriorly. Legs slender; tarsi 3-segmented; apical tibial spur formula 2:2:2. Cerci 2-segmented; styli absent.

## 2. *Distribution and Composition of Indotermitidae*

**Distribution** : South and South-east Asia, as follows:-

Bhutan, N.E. India (Meghalaya), Bangladesh, Burma, Thailand and S. China (Yunnan and Guangdong Provinces) (Fig. 2).

**Composition** : Comprises a single genus, *Indotermes* Roonwal and Sen-Sarma (syn. *Sinotermes* He and Xia).

### 3. *Phylogeny of Indotermitidae* (Fig. 306)

The family Indotermitidae is distinguished by several peculiar characters e.g., the 3-segmented tarsi in all the castes; the soldier densely hairy all over with massive, subsquarish, strongly hypognathus head and a very strongly saddle-shaped pronotum, etc. It may thus be visualised as having arisen as a lone sub-branch (3-segmented tarsi) from one of the two principal branches (with 4-segmented tarsi) which arose from the Ancient Termitidae stock (also initially 4-segmented) as shown in fig. 306 (For a detailed discussion vide Roonwal and Rathore, 1986).

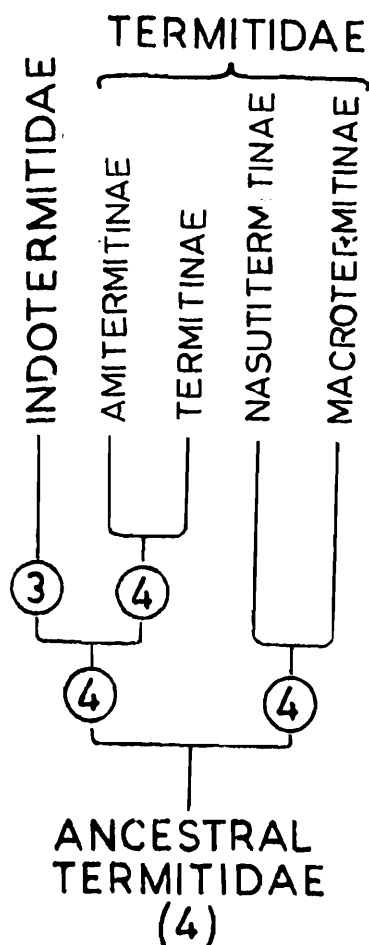

Fig. 306. Chart to show the phylogenetic origin of the family Indotermitidae. (The Arabic numerals, 3, 4, indicate the number of tarsal segments present.) (Ex Roonwal and Rathore 1986.)

**Genus 22. *Indotermes* Roonwal and Sen-Sarma**  
(Synonym *Sinotermes* He and Xia)

1. Genus *Indotermes*:

1958. Roonwal and Sen-Sarma (in Roonwal), *Trans. Bose Res. Inst.*, **22** : 81-82.

1960. Roonwal and Sen-Sarma, *Contrib. Syst. Oriental Termites* (ICAR Ent. Monogr. No:1) : 41.

1975. Roonwal, *Biol. Zbl.*, **94**(1) : 32-36.

2. Genus *Sinotermes* He and Xia

1981. He and Xia, *Contrib. Shanghai Inst. Ent.*, 1981: 197, 201.

Type of genus (i) of *Indotermes* *I. maymensis* Roonwal and Sen-Sarma. Burma. (ii) of *Sinotermes* *S. hainanensis* He and Xia. S. China. (The supposed differences of *Sinotermes* from *Indotermes* are inconsequential and it is not possible to differentiate the two.)

1. *Characters of Genus Indotermes*

As in the family, supra.

2. *Composition and Distribution of Indotermes*

*Composition* : Seven species are known, as follows:-

1. *I. arshadi* Akhtar. Soldier. Bangladesh.
2. *I. hainanensis* (He and Xia) (their *Sinotermes hainanensis*). Imago (dealate) and soldier. S. China (Guangdong Province).
3. *I. isodentatus* (Tsai and Chen) (their *Eurytermes isodentatus*). Imago and soldier. S. China.
4. *I. maymensis* Roonwal and Sen-Sarma. Soldier and worker. Burma.
5. *I. rongrensis* (Roonwal and Chhotani) (their *Speculitermes cyclops rongrensis*; syns. *Indotermes pakistanicus* Chaudhry and Ahmad, 1972, p. 47, nom. nud.; and *I. bangladeshiensis* Akhtar, 1975, p. 116). Imago, soldier and worker. N.E. India (Meghalaya), Bhutan, Bangladesh, Thailand.
6. *I. thailandis* Ahmad. Soldier and worker. Thailand.

7. *I. yunnanensis* (He and Xia) (their *Sinotermes yunnanensis*). Soldier.  
S. China (Yunnan Province).

*Distribution* (Fig. 307) : Bhutan, N.E. India (Meghalaya), Bangladesh, Burma, Thailand and S. China.

Of the seven known species, the following three occur in the Indian Region:- *arshadi*, *maymensis* and *rongrensis*.

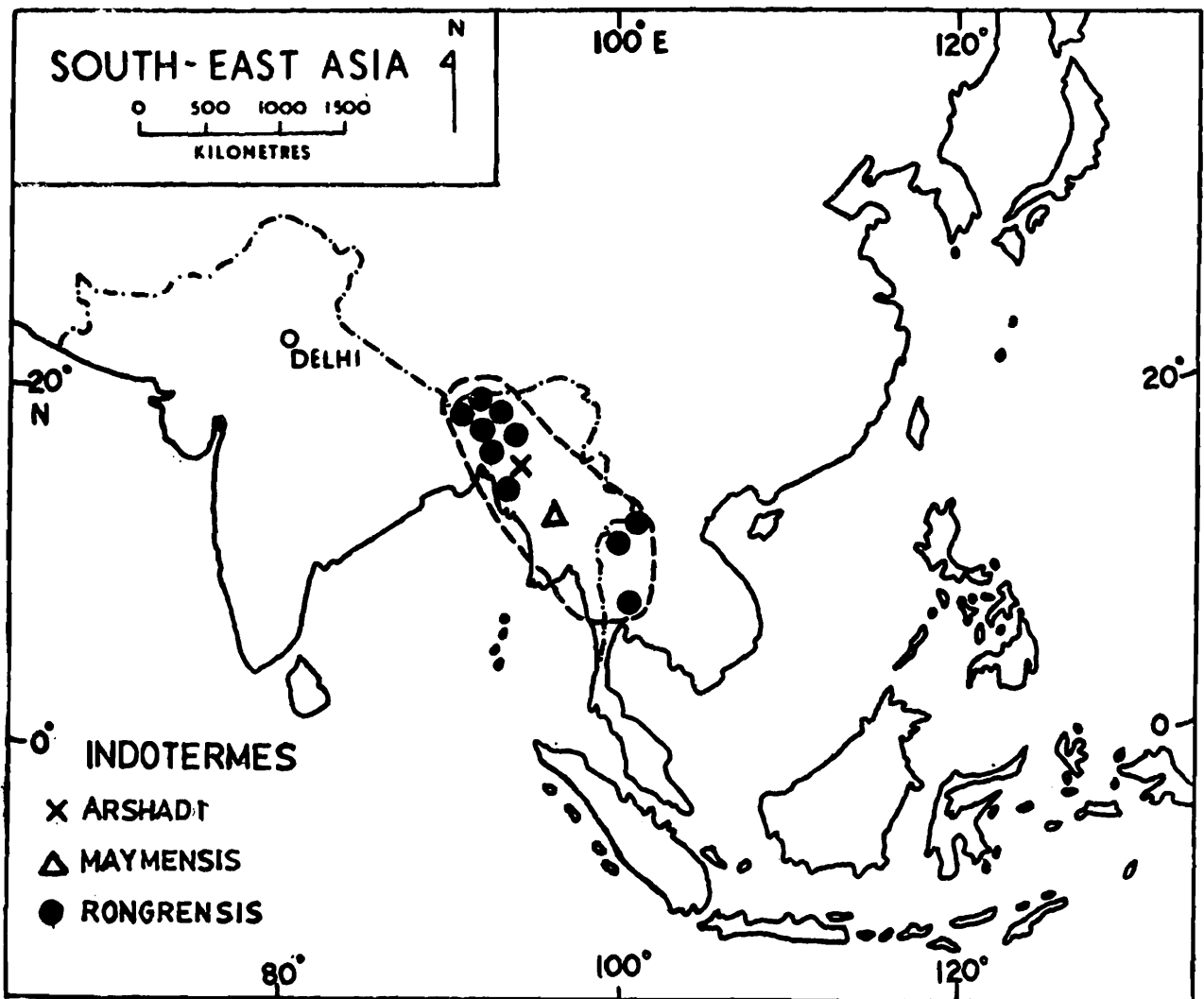

Fig. 307. Map of South-East Asia), showing the distribution of the Indian Region species of *Indotermes*.

### 3. Key to Indian Region Species of *Indotermes*

Imagoes are known in a single species (*I. rongrensis*) and soldiers in all three.

## SOLDIERS

- 1(2). Larger species. Head-length to base of mandibles 2.7-2.9 mm ..... *arshadi*
- 2(1). Smaller species. Head-length to base of mandibles 2.2-2.7 mm
- 3(4). Darker species. Head dark brown with smoky tinge; subsquarish to subrectangular, wider in comparison to length (index maximum width/length 0.93-0.97). Marginal teeth of right mandible triangular. .... *maymensis*
- 4(3). Paler species. Head brown with reddish tinge; subrectangular, less wide in comparison to length (index maximum width/length 0.82-0.87). Marginal teeth of right mandible subsquarish. .... *rongrensis*

96. *Indotermes arshadi* Akhtar  
(Fig. 308)

♣ 1. *Indotermes arshadi* Chaudhry and Ahmad :

1972. Chaudhry and Ahmad, *Termites of Pakistan (Final Tech. Rept., P.L. 480 Program.)*: 41. *Nom. nud.*

2. *Indotermes arshadi* Akhtar :

1975. Akhtar, *Bull. Dept. Zool. Univ. Panjab (Lahore)*, (N.S.), Art. 7, 114-116, 119, 193, Soldier. Holotype ; S in Zool. Dept. Panjab Univ., Lahore. Type-locality : Adampur, Bangladesh.

IMAGO: Unknown.

SOLDIER (Fig. 308): Head and body brown with reddish or smoky tinge; tip of abdomen yellowish, a white median streak runs from pronotum to 9th abdominal tergum. Head with a dense covering of short hairs and a few long bristles; postclypeus as hairy as head; labrum with a few somewhat longer hairs. Head subrectangular (length to base of mandibles 2.72-2.91 mm, maximum width 2.66-2.93 mm), large, heavy and strongly hypognathus, sides weakly convex; posterior margin weakly incurved; Y-suture faint. Eyes and ocelli absent. Antennae with 14-15 segments (in 15-segmented condition, segment 2 twice as long as 3). Clypeus clearly separated from frons. Labrum small, tongue-shaped, slightly longer than wide. Mandibles stout, shorter than head (length 1.51-1.68 mm), with several minute hairs at base; with a broad basal plate and a more slender,

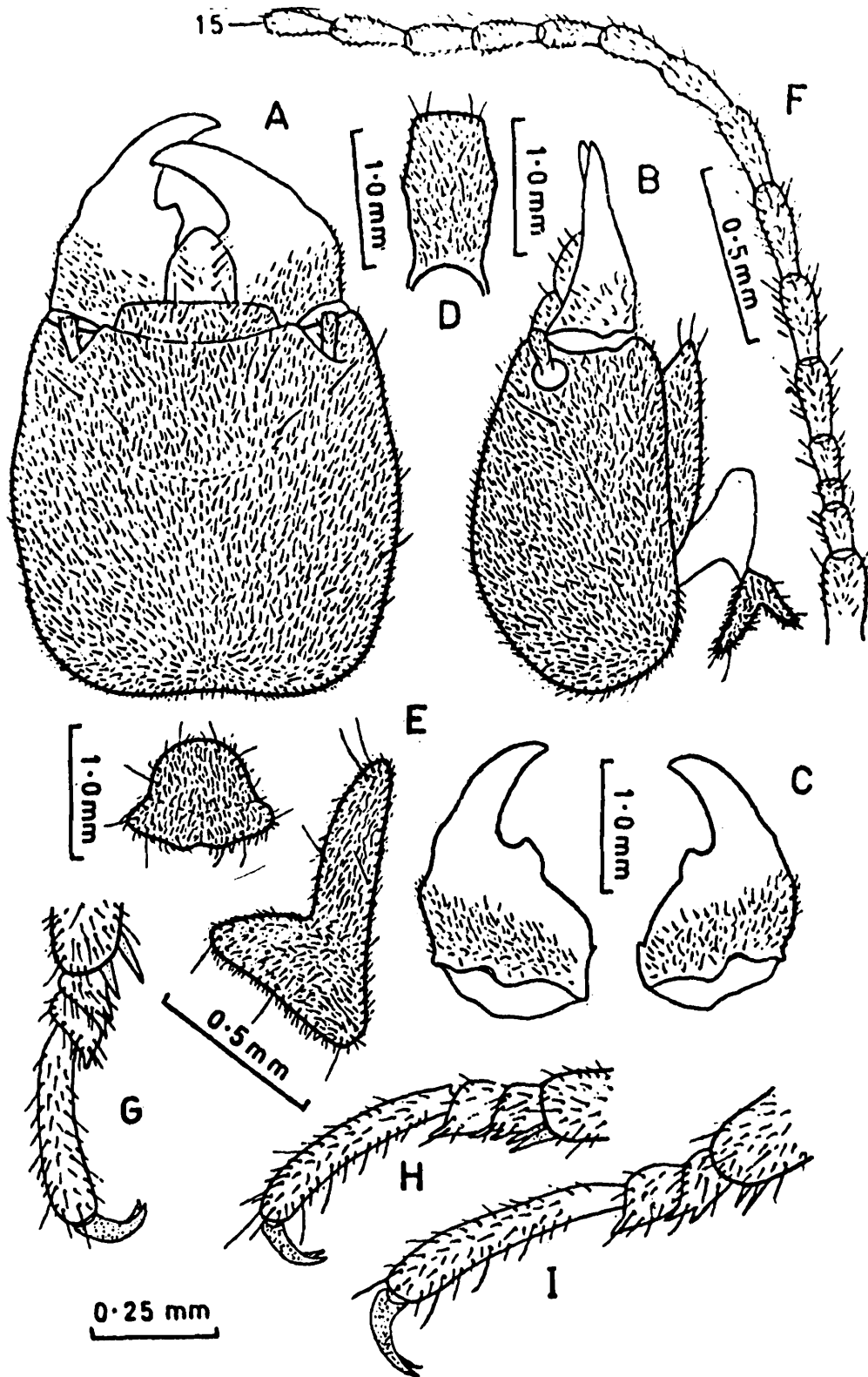

Fig. 308. *Indotermes arshadi*. Soldier (Bangladesh). (A) Head and pronotum, in dorsal view. (B) Same, in side view. (C) Mandibles. (D) Postmentum. (E). Pronotum, side view. (F) Antenna. (G) Distal part of foreleg. (H) Same, middle leg. (I) Same, hindleg. (Ex Akhtar 1975).

incurved distal part, a large tooth present on the inner margin between the two halves. Postmentum short (length 1.12-1.27 mm), club-shaped, with a bulge in distal one-third. Pronotum very hairy, much smaller than head (length 0.69-0.77, width 1.06-1.18 mm), strongly saddle-shaped, anterior lobe much longer than posterior; anterior margin convex, without a median notch; posterior margin weakly incurved. Legs with 3-segmented tarsi; apical tibial spur formula 2:2:2.

3. WORKER: Unknown.

*Distribution:* BANGLADESH : (North-eastern part, e.g., Adampur, 24.15 N, 91.47 E).

*Biology:* A subterranean species. The underground nest consists of small chambers connected by narrow passages. The chambers are used for the rearing of larvae and for the storage of small pieces of semi-digested wood. (Chaudhry and Ahmad 1972).

### 97. *Indotermes maymensis* Roonwal and Sen-Sarma (Figs. 309, 310)

*Indotermes maymensis* Roonwal & Sen-Sarma :

1958. Roonwal and Sen-Sarma In Roonwal, *Irans. Bose Res. Inst.*, 22: 81.

1960. Roonwal and Sen-Sarma, *Contrib. Syst. Orient. Termites*, New Delhi (ICAR, Ent. Monogr. No. 1): 42-45, Pls. VII, VIII. Soldier. Holotype : S in FRI, Dehra Dun. Type-locality : Maymyo, Burma (22.05 N, 96.30 E).

1965. Krishna, *Amer. Mus. Novitat.*, No. 2210 : 3-5. Workers. Burma.

1970. Roonwal, In *Biol. of Termites* (Ed. by Krishna and Weesner), Vol. 2: 384.

1970. Weidner, *Handb. d. Zool.*, Vol. 4 (Arthropoda), Sec. 2 (Insecta), Pt. 2 (Special), Lief. 13, No. 14, (Isoptera): 23-24.

1975. Akhtar, *Bull. Dept. Zool. Univ. Panjab (Lahore)*, (N.S.), Art. 7: 116, 119.

1975. Roonwal, *Biol. Zbl.*, 94(1) : 33.

IMAGO: Unknown.

SOLDIER (Figs. 309 and 310): Head dark brown with smoky tinge; clypeus, labrum, antennae, legs and abdomen pale brown. Head and body densely covered with small, thin, almost microscopic hairs, and a few longer bristles. Total length 8.0-10.0 mm. Head large, hypognathus, subsquarish,

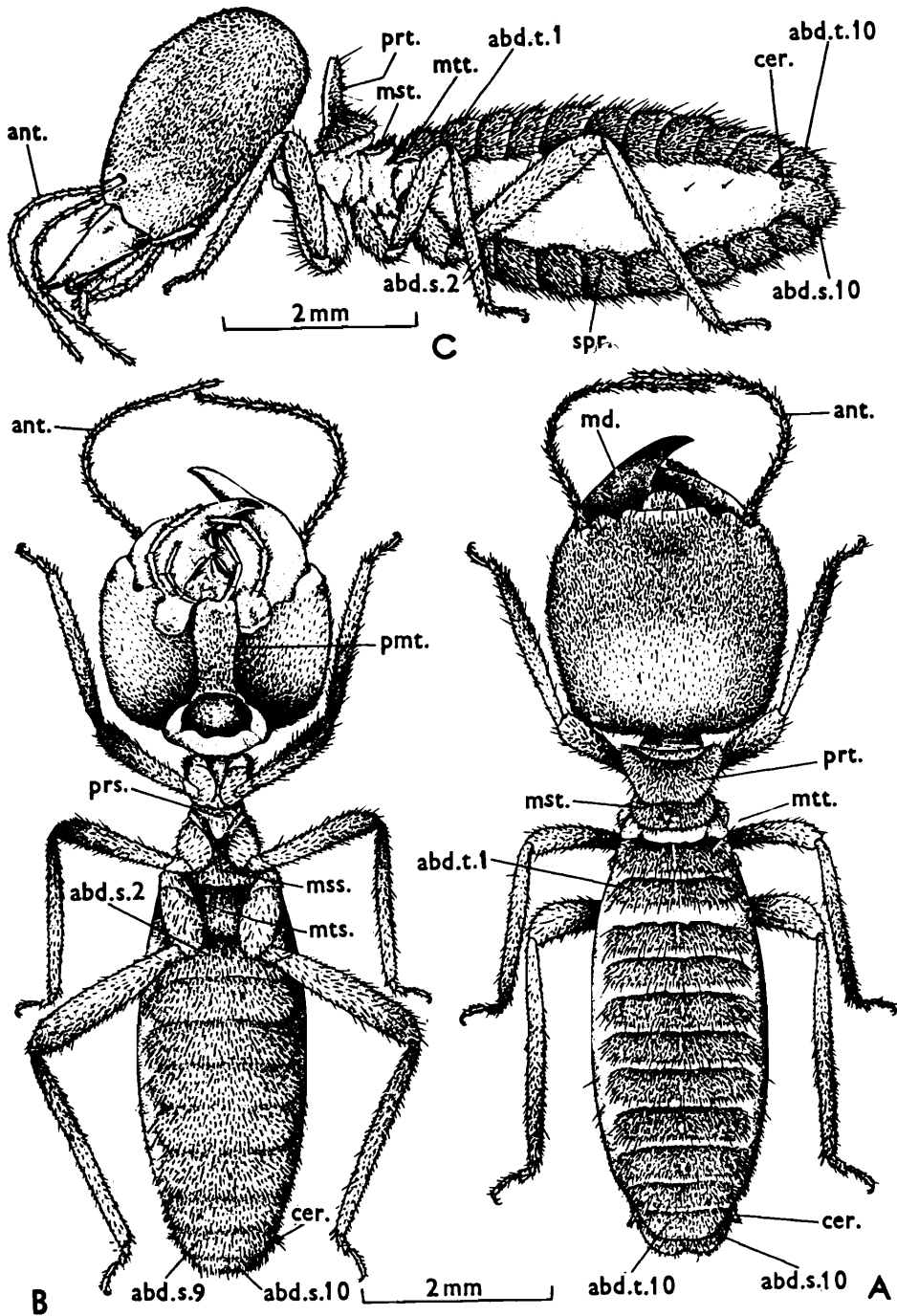

Fig. 309. *Indotermes maymensis* Roonwal and Sen-Sarma. Soldier (Paratype; Maymyo, Burma), (A) Whole body, in dorsal view. (B) Same, in ventral view. (C) Same, in side view. (Ex Roonwal and Sen-Sarma.)

abd.s. 2-abd.s. 10, second to tenth abdominal sterna; abd.t. 1- abd.t. 10, first to tenth abdominal terga. ant., antenna; cer., cercus; md. mandible; mss. mesonotum; mst., mesonotum; mts., metasternum; mtt., metanotum; pmt., postmentum; prs., prosternum; prt., pronotum; spr., spiracle.

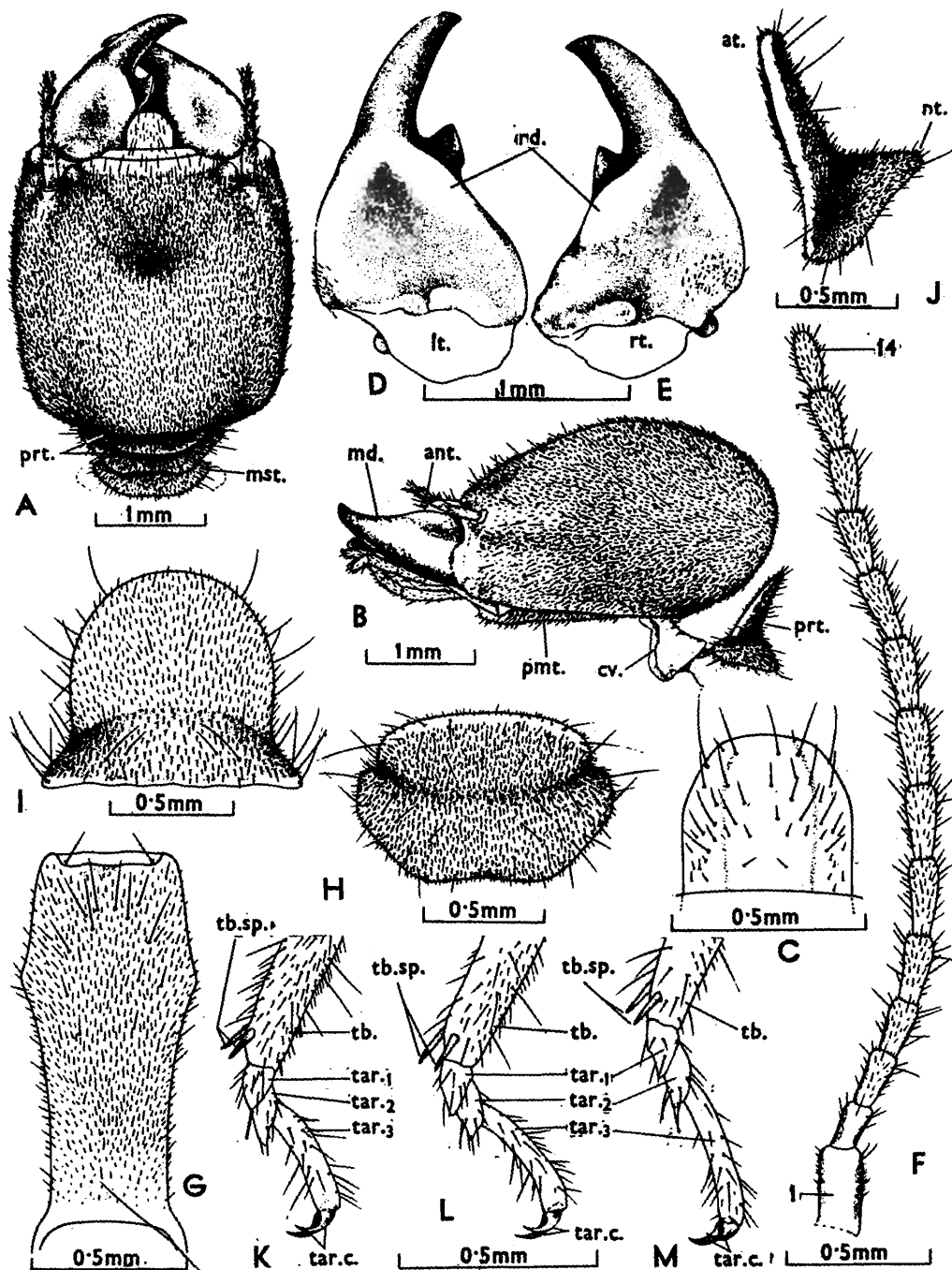

Fig. 310. *Indotermes maymensis* Roonwal and Sen-Sarma. Soldier (paratype : Maymyo, Burma). (A) Head and anterior part of thorax, in dorsal view. (B) Head and pronotum, in side view. (C) Labrum, in dorsal view. (D) and (E) Left and right mandibles. (F) Right antenna. (G) Postmentum. (H) Pronotum (in situ), in dorsal view. (I) Pronotum, showing anterior lobe as mounted on slide. (J) Same, in side view. (K), (L), (M) Distal parts of fore, middle and hind legs, respectively (Ex Roonwal and Sen-Sarma)

ant., antenna; at., anterior; lt., left; md., mandible; mst., mesonotum; pmt., postmentum; prt., pronotum; pt., posterior; rd., ridge; rt., right; tar. 1-tar. 3, first to third segments of tarsus; tb., tibia; tb. sp., tibial spurs.

with weakly rounded angles; length to mandible-base 2.40-2.65 (mean 2.56) mm; maximum width 2.2-2.6 (mean 2.40) mm.; height 1.40-1.65 (mean 1.55) mm.; index Width/Length 0.93-0.97. Frons gently sloping in front. Y-suture faint, with a weak depression between the lateral arms. Eyes and ocelli absent. Antennae longish, slender, with 14 segments; segment 2 shortest. Labrum small, slightly wider than long (0.3-0.35 x 0.38-0.45 mm.), bluntly tongue-shaped, moderately hairy; distal end rounded. Postclypeus and anteclypeus as narrow, transverse strips. Mandibles massive (length 1.40-1.65 mm), with a broad base and an abruptly attenuated narrow, pointed apical end; each with a large pointed tooth on inner margin at the distal end of the wide basal part. Postmentum short, (median length 1.15-1.35; maximum width 0.50-0.55 mm), subrectangular, with a bulge in the distal one-fourth. Pronotum small, less than half as wide as head, wider than long (0.45-0.60 x 1.05-1.15 mm); strongly saddle-shaped, anterior lobe much longer than posterior; anterior margin strongly rounded, posterior margin straight. Meso- and metanota flat, narrow, smaller than pronotum, sides rounded. Legs long and slender; apical tibial spurs 2:2:2. Tarsi 3-segmented; empodium absent. Abdomen long and rather swollen. Cerci small, 2-segmented; styli absent.

**WORKER:** Head subround (length to mandible-base 1.01-1.07, maximum width 1.20-1.32 mm); with a pale, subround mid-dorsal spot (diameter 0.07-0.13 mm). Mandibles with an apical and 2 marginal teeth; the second marginal small and, in left mandible, widely separated from the first. Pronotum wider than long (0.40-0.46 x 0.66-0.74 mm). Tarsi 3-segmented.

*Distribution* : BURMA (central part: Maymyo, 22.05 N, 96.30 E; alt. 914 m; Pa-an, 17.56 N, 97.36 E).

**98. *Indotermes rongrensis* (Roonwal and Chhotani)**  
(Figs. 311-315)

(Synonyms : *Speculitermes cyclops rongrensis* Roonwal and Chhotani; *I. pakistanicus* Chaudhry and Ahmad; *I. bangladeshiensis* Akhtar.)

1. *Speculitermes cyclops rongrensis* Roonwal and Chhotani :

1962. Roonwal and Chhotani, *Proc. natnl. Inst. Sci. India*, (B)28 (4) : 314. Worker.  
Type-locality : Rongrengiri (Garo Hills, Meghalaya, India). Holotype worker, in Zoological Survey of India, Calcutta.

1965. Roonwal and Chhotani, *J. Bombay nat. Hist. Soc.*, **62** : 21, 28. Meghalaya.

2. *Speculitermes rongrensis* Roonwal and Chhotani :

1973. Morimoto, *Bull. Govt. Forest Exper. Sta.*, No. 257: 62-63. Thailand. Imago.

1977. Roonwal and Chhotani, *Ent. Basiliensia*, Basel, **2** : 50-53. Bhutan. Imago.

1980. Roonwal and Verma, *Proc. Indian natnl. Sci. Acad.*, (**B**)**46** (3) : 253-254. Bhutan. Wing microsculpturing.

3. *Indotermes rongrensis* (Roonwal and Chhotani) :

1986. Roonwal and Chhotani, *Rec. zool. Surv. India*, **83**(3&4): 155-162. Imago, soldier, worker. N.E. India (Meghalaya).

4. *Indotermes pakistanicus* Chaudhry and Ahmad :

1972. Chaudhry and Ahmad, *Termites of Pakistan (Final Tech. Rept., P.L. 480 Program.)*: 42, Soldier, worker. Bangladesh. *Nom. nudum*.

5. *Indotermes bangladeshiensis* Akhtar:

1975. Akhtar, *Bull. Dept. Zool. Univ. Panjab* (Lahore) (N.S.), Art. 7 : 113, 114, 115-120. Imago, soldier. Holotype S in Zool. Dept. Panjab Univ., Lahore. Type-locality : Bangladesh (S.E. part, Ukhia).

**IMAGO (Figs. 311-313):** Head and body blackish brown, labrum paler. Head and body with a thick mat of short hairs and a few longer bristles. Total length with wings 18.0-18.6 mm, without wings 8.8-10.6 mm. Head hypognathus, subcircular (length to tip of labrum 1.80-2.05 mm, to mandible-base 1.16-1.27 mm, width with eyes 1.67-1.80 mm); Y-suture faint; mid-dorsal spot large, suboval to subtriangular (diameters 0.21-0.28 x 0.17-0.20 mm), slightly swollen and raised from head-surface. Eyes subround (maximum diameter 0.43-0.51 mm). Ocelli oval (0.18-0.19 x 0.13-0.17 mm), separated from eyes by less than the short diameter of ocelli (minimum eye-ocellus distance 0.07-0.10 mm). Anteclypeus apilose, hyaline, with a pale yellow arc or V-mark. Postclypeus slightly swollen, subtrapezoidal (0.27-0.30 x 0.67-0.80 mm). Labrum broad, tongue-shaped (0.43-0.50 x 0.57-0.60 mm). Antennae longish, with 15 segments, segment 3 shorter than 2. Mandibles with an apical and two marginal teeth. Pronotum trapezoidal, weakly saddle-shaped; anterior margin substraight, with or without a weak, median notch; posterior margin with a prominent median notch. Posterior margins of meso- and metanota also deeply notched. Legs long, hairy; tarsi 3-segmented;\* tibial apical spur formula

---

\*Earlier, Roonwal and Chhotani (1977, p. 52 gave the tarsi as 4-segmented. We have re-examined the Bhutan examples and find them to be 3-segmented.

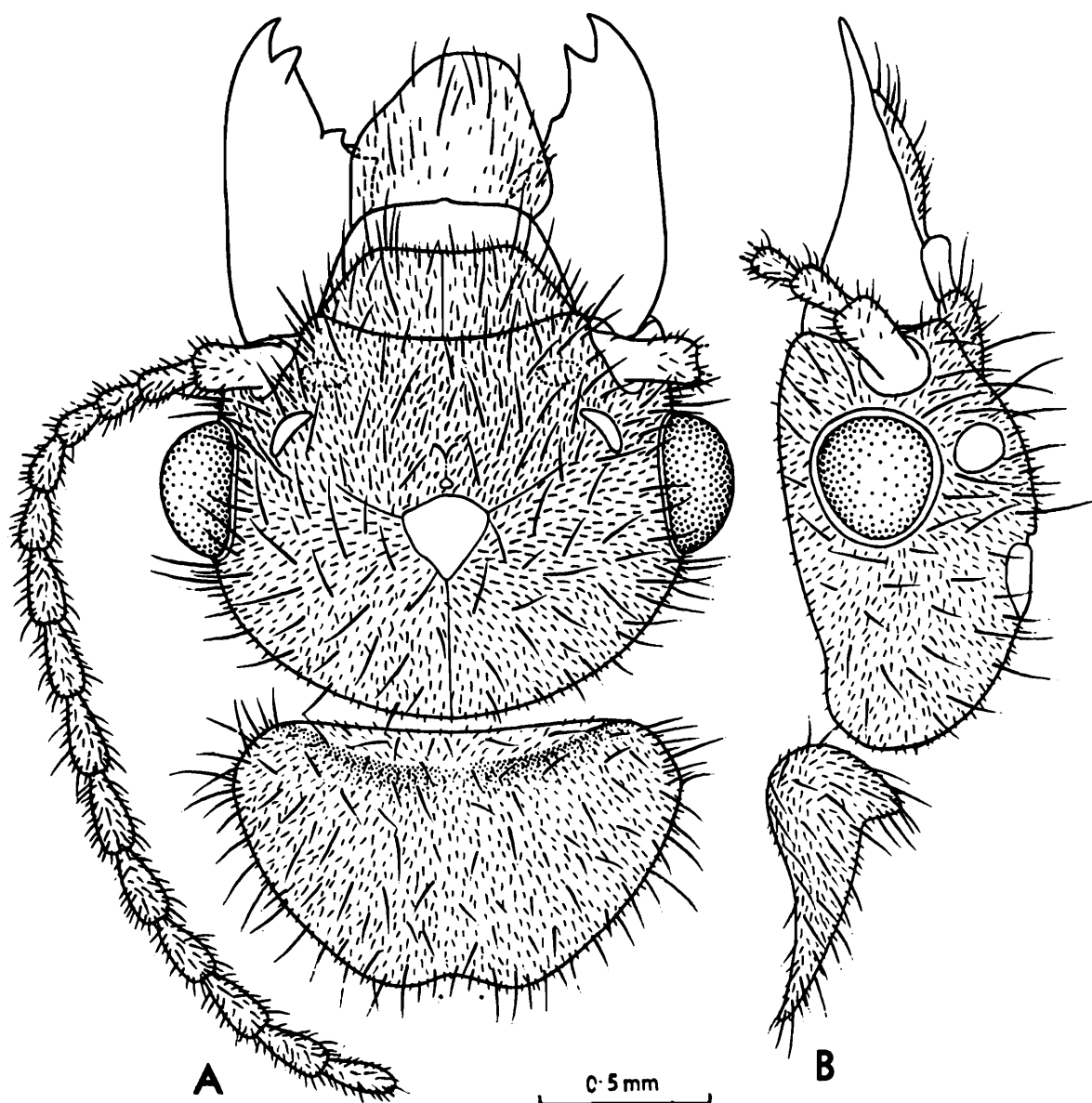

Fig. 311. *Indotermes rongrensis*. (Roonwal and Chhotani). Imago (Bhutan). (A) Head and pronotum, in dorsal view. (B) Same, in side view. (Ex Roonwal and Chhotani 1977.)

2:2:2; empodium between claws absent. Wings transparent, colourless, scales and base brown; weakly hairy. Length with scale, forewings 13.0-16.0 mm, hindwings 12.0-14.5 mm; maximum width, forewings 3.30, hindwings 3.45 mm; forewing scale not covering hindwing scale; venation as in the family, supra. Wings covered on both sides with a row of small

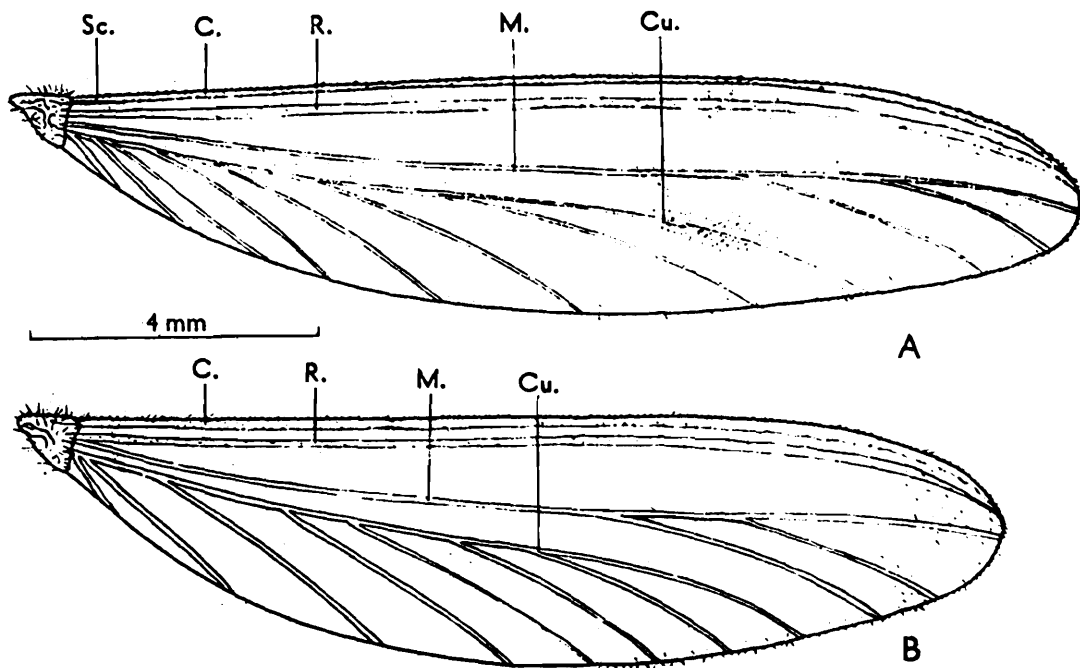

Fig. 312. *Indotermes rongrensis*. (Roonwal and Chhotani). Right wings of imago (from Meghalaya, India). (A) Forewing. (B) Hindwing. (Ex Roonwal and Rathore 1986, C, costa; Cu, cubitus; M, media; R, radius; Sc, subcosta.

(1-3  $\mu\text{m}$  long), pointed papillae at the anterior margin, and a dense carpet (density 3100-3800/ $\text{mm}^2$ ) of minute (1-6  $\mu\text{m}$ ), simple, colourless, non-asteroid micrasters (rods and with V and Y shapes). Abdomen oblong, densely pilose. Cerci short, 2-segmented. Styli absent.

**SOLDIER** (Figs. 313, 314): Head brown, with reddish tinge. Pronotum darker, with a white, median streak extending to 9th abdominal tergum. Head and pronotum densely pilose with small hairs and a few longer bristles. Total length 7.2-7.3 mm. Head subrectangular (length to mandible-base 2.24-2.50 mm, maximum width 1.91-2.18 mm; index Width/Length 0.82-0.87); strongly hypognathus; Y-suture faint; mid-dorsal spot absent. Eyes and ocelli absent. Antennae long, with 14 segments, segment 2 shortest. Anteclypeus hyaline, apilose, anterior margin substraight. Postclypeus demarcated from frons only at the lateral corners; with a few hairs. Labrum very small (in relation to the massive head), tongue-shaped, slightly longer

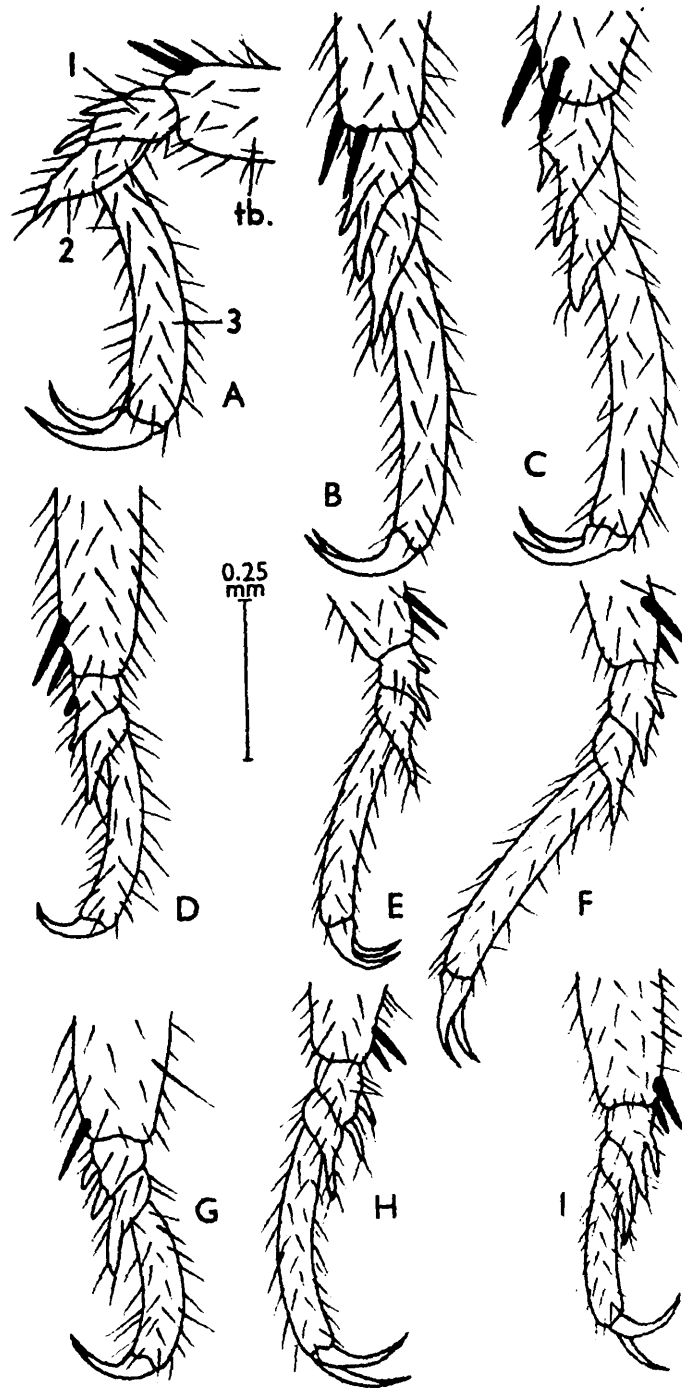

Fig. 313. *Indotermes rongrensis*. (Roonwal and Chhotani). Distal parts of legs. (A), (B), (C) Imago; fore, middle and hind legs, respectively. (D), (E), (F) Soldier; fore, middle and hind legs, respectively. (G), (H), (I), Worker; fore, middle and hind legs, respectively. (Ex Roonwal and Chhotani 1986.)

tb., tibia; 1, 2, 3, first, second and third tarsal segments, respectively.

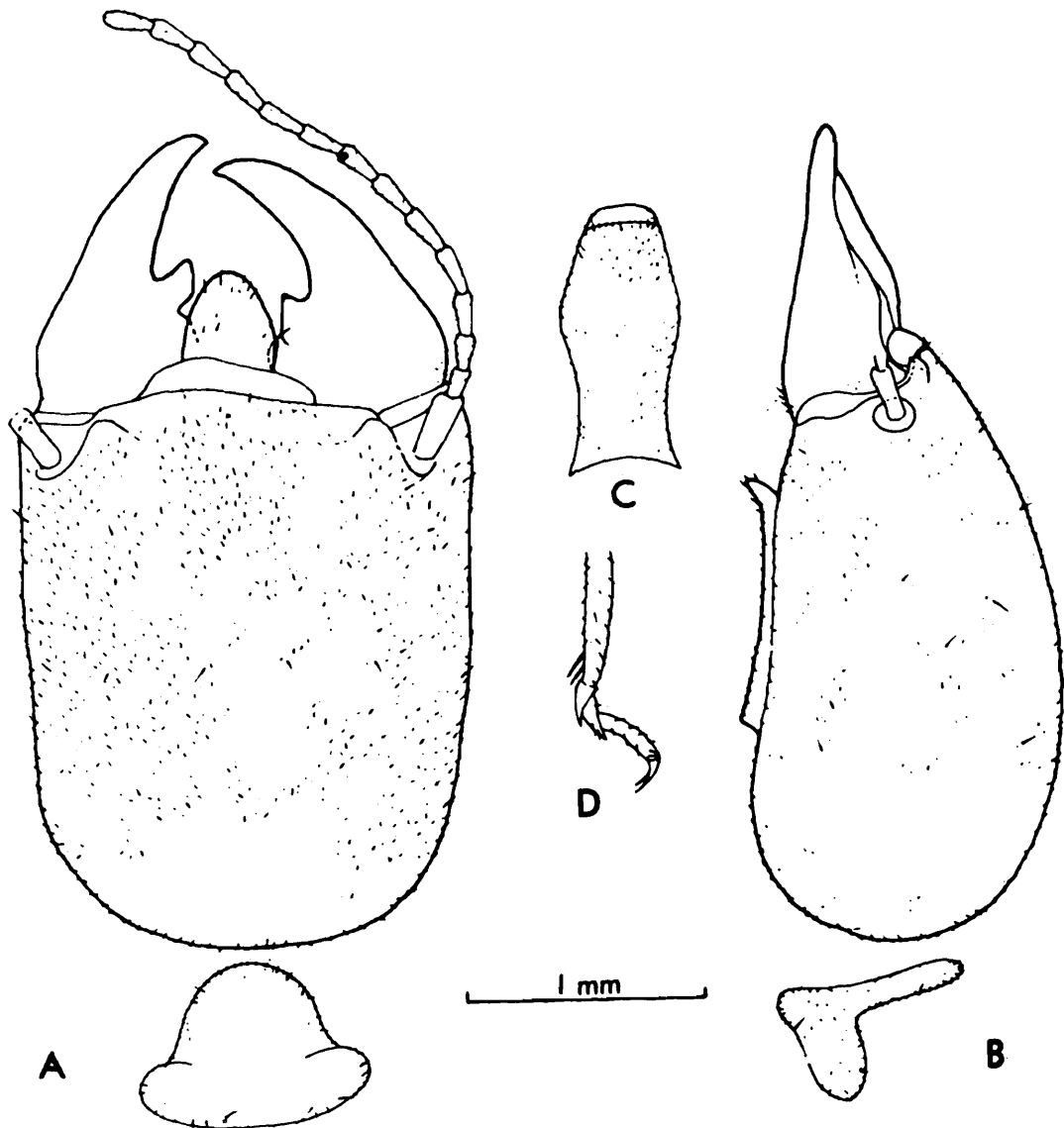

Fig. 314. *Indotermes rongrensis*. (Roonwal and Chhotani). Soldier (Meghalaya, India).  
 (A) Head and pronotum, in dorsal view. (B) Same, in side view. (C) Postmentum.  
 (D). Distal part of hind leg.

than wide (length 0.44-0.47, width 0.44 mm). Mandibles much shorter than head (slightly longer than half the head-length; length 1.37-1.40 mm; index Mandible-length/Head-length 0.55-0.56); massive, with a large basal plate and a slender, attenuated, pointed, incurved apical part, with a large, pointed tooth at the junction of the two parts on the inner margin, the left tooth larger than the right. Postmentum slightly raised, club-shaped, with a bulge in the middle; short in relation to head; length 0.93-1.25, maximum width 0.50-0.56 mm, index Postmentum length/Head-length 0.60; anterior margin weakly convex, the posterior slightly incurved. Pronotum much

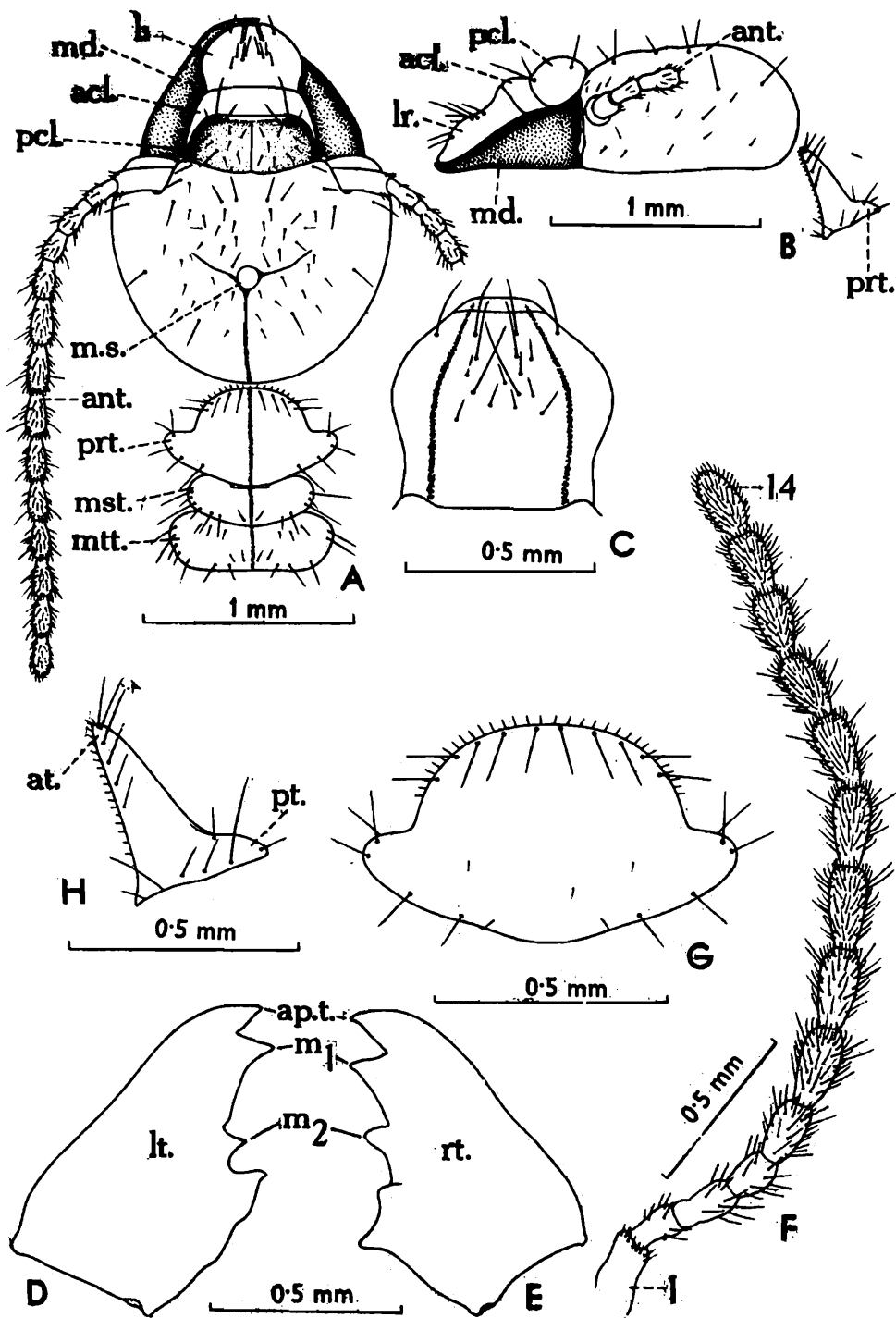

Fig. 315. *Indotermes rongrensis*. (Roonwal and Chhotani). Worker (Meghalaya, India). (A) Head and thorax, in dorsal view. (B) Head and pronotum, in side view. (C) Labrum (mounted on slide), in dorsal view. (D), (E). Left and right mandibles. (F) Antenna. (G) Pronotum, in dorsal view. (H) Same, in side view. acl., anteclypeus; ant., antenna; ap.t., apical tooth of mandible; at., anterior; lar., labrum; lt., left;  $m_1$ - $m_2$ , first and second marginal teeth of mandibles; md., mandibles; m.s., mid-dorsal spot; mst., mesonotum; mtt., metanotum; pcl., postclypeus; prt., pronotum; pt., posterior; rt., right.

smaller than head (length 0.72-0.82, maximum width 0.99-1.06 mm); strongly saddle-shaped, anterior lobe much longer than posterior; anterior margin convex, strongly rounded, posterior margin weakly incurved. Legs long, thin; tarsi 3-segmented; apical tibial spur formula 2:2:2. Abdomen oblong, weak and delicate (in relation to the massive head). Cerci 2-jointed; styli absent.

**WORKER** (Figs. 313, 315): Head and body brown; a pale median streak running from pronotum to the first few abdominal terga. Head and body moderately hairy. Total length 3.5-5.4 mm. Head subcircular (length to mandible-base 1.10-1.13, maximum width 1.25-1.35 mm); Y-suture well developed; mid-dorsal spot large, roundish and slightly raised (diameter 0.10-0.12 mm). Antennae long, slender, with 14 segments; segment 2 shorter than 3 and subequal to 4. Anteclypeus whitish, trapezoid, apilose; postclypeus darker, slightly swollen, weakly hairy. Labrum dome-shaped, broadest in middle, with a few bristles in the centre. Mandibles with an apical and two marginal teeth. Pronotum much narrower than head (length 0.40-0.45, maximum width 0.68-0.75 mm), strongly saddle-shaped, anterior lobe longer than posterior; anterior margin rounded, posterior one slightly protruding and narrow, both without a median notch. Legs long, slender; tarsi 3-segmented\*; apical tibial spur formula 2:2:2. Abdomen oblong and swollen; terga strongly chitinised. Cerci 2-jointed; styli absent.

*Distribution* : Bhutan, N.E. India and further south-east to Thailand, thus: BHUTAN : Puntsholing, altitude 200-400 m, Samchi and Thimpu River bank. N.E. INDIA : Meghalaya (the Garo and the Khasi and Jaintia Hills. BANGLADESH : Ukhia (Chittangong District). THAILAND : Fang, Chieng Dao and Mae Klang Waterfall (northern and south-western parts).

*Remarks* : Initially described, from workers only from Meghalaya (India), as *Speculitermes cyclops rongrensis* by Roonwal and Chhotani (1962). Subsequently, the imago was described, as *S. rongrensis*, by Morimoto (1973, from Thailand) and by Roonwal and Chhotani (1977, from Bhutan, pp. 50-53, Fig. 5, actually the block above Fig. 6 on p. 54). A more recent complete collection of all castes (with associated imagoes, soldiers and workers) made a reassessment of identity possible (for a discussion vide Roonwal and Chhotani, 1986).

---

\*Earlier, Roonwal and Chhotani 1962a,p. 315) gave the tarsi as 4-segmented. We have re-examined the holotype and paratypes and found the tarsi to be 3-segmented.

## BIBLIOGRAPHY

- ABE, Y 1937a. Notes on the relations between the temperature and the distribution of oriental termite, *Coptotermes formosanus* Shiraki, in Japan. (In Japanese.) *Kontyu*, **11** 137.
- ABE, Y 1937b. On the distribution of the oriental termite, *Coptotermes formosanus* Shiraki, in Japan. *Sci. Rept. Tohoku Univ. (Biol.)*, (4)**11** 463-472, 3 maps.
- AHMAD, M. 1950. The phylogeny of termite genera based on imago-worker mandibles. *Bull. Am. Mus. nat. Hist.*, **95** (Art. 2) (1-6) + 43 - 86.
- AHMAD, M. 1953. Two new cases of introduction of termites. *Spolia zeylan.*, **27**(1) 35-36.
- AHMAD, M. 1955 (Dec.). Termites of West Pakistan. *Biologia* (Lahore), **1**(2) 202-264.
- AHMAD, M. 1958a. Key to Indomalayan termites. (Part 1.) *Biologia* (Lahore), **4**(1) 33-118.
- AHMAD M. 1958b. Key to Indomalayan termites (concluded). *Biologia* (Lahore), **4**(2) : 119-198 + i - xii (index)
- AHMAD, M. 1962. Termite fauna of West Pakistan. In *Termites in the Humid Tropics* : (Proc. New Delhi Sympos., 1960) : 67-68. Paris (Unesco).
- AHMAD, M. 1963 (July). On the phylogenetic position of *Indotermes*, with description of a new species (Isoptera, Termitidae). *Ann. Mag. nat. Hist.*, (13)**6**, pp. 395-399.
- AHMAD, M. 1965. Termites (Isoptera) of Thailand. *Bull. Am. Mus. nat. Hist.*, **131**(Art.1): 1-113.
- AKHTAR, M.S. 1974a. New termites from Pakistan. *Biologia* (Lahore), **20**(1) : 23-61.

- AKHTAR, M.S. 1974b. Zoogeography of the termites of Pakistan. *Pakistan J. Zool.*, **6** 85-104.
- AKHTAR, M.S. 1975. Taxonomy and zoogeography of the termites (Isoptera) of Bangladesh. *Bull. Dept. Zool. Univ. Panjab*, Art. 7 : 1-199.
- AKHTAR, M.S. 1979. On a palaeartic termite genus *Anacanthotermes* Jacobson (Isoptera) in Pakistan. *Biologia* (Lahore), **25** 161-170.
- AMPION, M. 1980. *Les Glandes Tergales des Imagos de Termites : Etude Comparative et Signification Evolutive*. Doctoral Thesis (3e grade) Univ. of Dijon, Dijon, (viii) + 107 pp. Summary in *Termite Abstrs.*, **1**(4) 1 (1981).
- AMPION, M. AND QUENNEDY, A. 1980. L'évolution des glandes tergaes et sternale dans la phylogenese de termites. (Abstract.) In *Int. Sympos. Biosystemat. Soc. Insects* (Paris, Jan. 1980) : 25. Paris (Int. Un. Study Soc. Insects).
- AYYAR, T.V.R. 1940. *Handbook of Economic Entomology for South India*. viii + 1 + 528 pp. Madras. (Suptd. Govt. Printing, Madras). (Reprinted 1984, New Delhi : Int. Book and Periodicals Supply Serv.)
- BANKS, N. 1919. Antillean Isoptera. *Bull. Mus. Comp. Zool., Harvard Coll.*, **62**(110) : 475-489, 2 pls.
- BANKS, N. AND SNYDER, T.E. 1920. A revision of the nearctic termites with notes on biology and geographic distribution. *Bull. U.S. natn. Mus.*, No. 108 1-228.
- BATHELLIER, J. 1927. Contribution a l'étude systematique et biologique des termites de l'Indochine. *Faune colon. Fr.*, **1**(4): 4 + 125-365, 13 pls.
- BECKER, G. 1975. *Heterotermes indicola* (Ins., Isoptera) damaging wood in buildings at Kathmandu (Nepal). *Material u. Organismen*, **10**: 260-275.
- BEESON, C.F.C. 1941. *The Ecology and Control of the Forest Insects of India and the Neighbouring Countries*. ii + 1007 pp., many figs. Dehra Dun (Vasant Press). (Reprint 1961, 8 + 10 + 767 pp. Manager of Publ., Govt. of India, Delhi.)
- BOSE, GEETA., See CHHOTANI, G. 1970. (Same person.)

- BOSE, GEETA, 1976. A further record of *Neotermes andamanensis* Snyder, the little known termite of the Andamans. *Newslet. zool. Surv. India*, 2(3): 104.
- BOSE, GEETA, 1979. A new species from India of the termite genus *Procryptotermes* Holmgren (Kalotermitidae), with a description of the hitherto unknown imago of *P. dhari* Roonwal and Chhotani. *Bull. zool. Surv. India*, 2(1): 53-59.
- BOSE, GEETA, 1980. A further contribution to the study of termite fauna of Andaman and Nicobar Islands. *Rec. zool. Surv. India*, 77: 93-109.
- BOSE, G. 1984. Termite fauna of Southern India. *Occ. Pap. Rec. zool. Surv. India*, No. 49: ix + 1-270 + 1 pp.
- BOSE, GEETA AND DAS, B.C. 1982 (Dec.). Termite fauna of Orissa, eastern India. *Rec. zool. Surv. India*, 80(1-2): 197-213, 1 flgd. table.
- BOSE, G. AND DAS, B.C. 1987. Check list of *In Fauna of Orissa. State Fauna Series*, No. 1: 103-111.
- BOSE, GEETA AND MAITI, P.K. 1976. Genus *Prorhinotermes* Silvestri from the Indian mainland. *Newslet. zool. Surv. India*, 2(1): 15-16.
- BOSE, G. AND ROY, P.H. 1984. On a small collection of termites (Isoptera, Insecta) from Bangladesh, with notes on distribution. *Bull. zool. Surv. India*, 5(2-3): 189-190.
- BRAUER, F. 1865. Fünfter bericht uber die auf der Weltfahrt der kais. Fregatte *Novara* gesammelten Neuropteren. *Verh. zool. - bot. Ges. Wien*, 15: 975-978.
- BRAUER, F. 1866. *Reise der osterreichischen Fregatte Novara um die Erde in den Jahren 1857, 1858, 1859 unter den Befehlen des Commodore B. von Wullerstorf-Urbair, Zoologischer Theil. Band 2 (Abth. 1, Art. 4). Neuropter.*, pp. 1-104, 2 pls. Vienna (kais. - konig. Hof-u. Staatsdruckeri).
- BRULLÉ, A. 1832. Des animaux articulés. *Exped. sci. Morée*, 3(1) (*Zoologie*): 66, 100. (Order Isopteres.)
- BUGNION, E. 1912. *Eutermes lacustris* n. sp. de Ceylon. *Revue suisse Zool.*, 20(8): 487-505, 2 pls.

- BUGNION, E. 1913a. Les termites de Ceylan avec quelques indications sur la distribution géographique de ces insectes. *La Globe (Mem.)*, 52: 24-58, 8 pls.
- BUGNION, E. 1913b. Liste des termites indomalais, avec l'indication du nombre des articles des antennes dans les trois castes. *Bull. Soc. Vaud. Sci. nat.*, 49(180): 165-172.
- BUGNION, E. 1914. Le *Termitogeton umbilicatus* Hag. (de Ceylan). (Corrodentia, Termitidae.) *Annls Soc. ent. Fr.*, 83(1): 39-47, 1 pl.
- BUGNION, E. 1915. Le biologie des termites de 'Ceylan. (Corrodentia, Termitidae). *Bull. Mus. natn. Hist. nat.*, 20(4) (1914): 170-204, 8 pls.
- BUGNION, E. AND FERRIERE, C. 1911. L'imago du *Coptotermes flavus*. Larvae portant des rudiments d'ailes prothoraciques. *Mem. Soc. zool. Fr.*, 24(7): 97-106, 2 pls.
- BUGNION, E. AND POPOFF, N. 1910a. Le termite a latex de Ceylan (*Coptotermes travians* Haviland). Avec un appendice comprenant la description des *Coptotermes Gestroi* Wasm. et *flavus* nov. sp. *Mem. Soc. zool. Fr.*, 23(8): 107-123, 2 pls.
- BUGNION, E. AND POPOFF, N. 1910b. Les *Calotermes* de Ceylan. *Mem. Soc. zool. Fr.*, 23(9): 124-144, 3 pls.
- CHATTERJEE, P.N. AND THAKUR, M.L. 1963. Biology and ecology of oriental termites (Isoptera). Some observations on *Sarvaritermes faveolus* Chatterjee & Thakur (Isoptera Stylotermitidae). *Indian Forester*, 89(9): 635-637, 1 pl.
- CHATTERJEE, P.N. AND THAKUR, M.L. 1964. *Sarvaritermes faveolus* gen. et. sp. nov. from Kulu Valley (Punjab : India) [Isoptera], with a discussion on the systematic position and relationship of the family Stylotermitidae. *Zool. Anz.*, 173(2): 149-162.
- CHATTERJEE, P.N. AND THAKUR, M.L. 1967. Contributions to the knowledge of systematics of North-Western Himalayan termite fauna (Insecta Isoptera). III. Systematic account of the survey. *Indian Forest Rec. (N.S.) (Ent.)*, 11(1): 1-57.
- CHATTERJEE, P.N. AND THAKUR, M.L. 1968. On a collection of termites from Daman. *Indian Forester*, 94(7): 560-567.

- CHAUDHRY, M.I. AND AHMAD, M. 1972. *Termites of Pakistan. Identity, Distribution and Ecological Relationships. (Final Technical Report.)* xiv + 70 + 3 pp. + 15 pls. + 2 pp. (errata) + 81 pp. (figs.) + 3 pp. (index). Peshawar (Pakistan Forest Inst.). PL—480 programme. [Both West Pakistan and East Pakistan (Bangladesh). 36 genera and 89 species listed. One n. g., 33 n. sp., all are *nomena nuda*; but distribution and habits given]
- CHHOTANI, G. (nee BOSE, G.). 1970. Termite fauna of southern India No. 1. Kalotermitidae. *Proc. 57th Sess. Indian Sci. Congr.* (Kharagpur, 1970, Pt. 3, Abstr.) : 438.
- CHHOTANI, O.B. 1959. Biological observations on the termite *Kalotermitis beelsoni* Gardner. *Abstrs, Papers 1st All-India Congr. Zool.* (Jabalpur, 1959): 43-44.
- CHHOTANI, O.B. 1962a. Biological observations on the termite *Kalotermitis beelsoni* Gardner. *Proc. 1st All-India Congr. Zool.* (Jabalpur, 1959), Pt. 2, (Sci. Papers) : 476-478, 1 pl.
- CHHOTANI, O.B. 1962b. Further observations on biology and parthenogenesis in the termite *Kalotermitis beelsoni* (Kalotermitidae). In *Termites in Humid Tropics* (Proc. New Delhi Sympos., 1960): 73-75. Paris (Unesco).
- CHHOTANI, O.B. 1963. The termite *Cryptotermitis havilandi* (Sjöstedt) from the interior of India. *J. Bombay nat. Hist. Soc.*, 60(1): 287-288, 1 pl.
- CHHOTANI, O.B. 1970 (Dec.). Taxonomy, zoogeography and phylogeny of the genus *Cryptotermitis* (Isoptera : Kalotermitidae) from the Oriental Region. *Mem. zool. Surv. India*, 15(1): 2 + ii + 1-81.
- CHHOTANI, O.B. 1972. Problems of taxonomy of the Indian termites. In *Termite Problems in India* (Ed. by M.L. Roonwal): 22-27. New Delhi (Counc. sci. & ind. Res.)
- CHHOTANI, O.B. 1975a. Revision of the genus *Glyptotermitis* Fröggatt (Kalotermitidae, Isoptera, Insecta) from the Indian Region. *Rec. zool. Surv. India*, 60(1-4) (1970) : 109-159.
- CHHOTANI, O.B. 1975b. Kalotermitidae of the Oriental Region : Its distribution and zoogeography. *Zool. Anz.*, 194 (1-2) : 111-124.

- CHHOTANI, O.B. 1976. On the occurrence of the termite *Cryptotermes dudleyi* Banks in the interior on the mainland. *Newslet. Zool. Surv. India*, 2(5): 211-212.
- CHHOTANI, O.B. 1977a. Termites of Kanha National Park (Madhya Pradesh), India. *Rec. zool. Surv. India*, 72: 367-388, 5 pls.
- CHHOTANI, O.B. 1977b. A review of taxonomy of Indian termites. *Occ. Pap. Rec. zool. Surv. India*, No. 9, 4 + 36 pp.
- CHHOTANI, O.B. 1977c. Distribution and zoogeography of the oriental termites of families Termopsidae, Hodotermitidae, Stylotermitidae and Rhinotermitidae. *Proc. 8th int. Congr. Int. Un. Stud. Soc. Insects*, Wageningen, Sept. 1977) (Ed. by J. de Wilde), Wageningen : 116-117.
- CHHOTANI, O.B. 1979. A review of Oriental Rhinotermitidae and Stylotermitidae (Isoptera). *Abstrs. Workshop Adv. Insect Taxon. India & Orient* (Manali, Oct. 1979): 43-44.
- CHHOTANI, O.B. 1980. Termite pests of agriculture in the Indian Region and their control. *Tech. Monogr. Zool. Surv. India*, No. 4: 4 + 94 pp., 7 pls.
- CHHOTANI, O.B. 1981. Soil termites of India. In *Progress in Soil Biology and Ecology in India* (Ed. by G.K. Veeresh): 229-236. Bangalore (Univ. Agric. Sci.).
- CHHOTANI, O.B. 1983. A review of the Rhinotermitidae and Stylotermitidae (Isoptera) from the Oriental Region. *Orient. Insects*, 17: 109-125.
- CHHOTANI, O.B. 1985. Distribution and zoogeography of the Oriental termites of families Termopsidae, Hodotermitidae, Stylotermitidae and Rhinotermitidae. *Z. ang. Ent.*, 100: 88-95.
- CHHOTANI, O.B. 1986. Affinities of Indian North-eastern borderland termites with those from other parts of the Oriental Region. *Rec. zool. Surv. India*, 83 (3 & 4): 19-21.
- CHHOTANI, O.B. (In press). Termites of Oman. *J. Oman Studies Spec. Rep.*, No. 3 :
- CHHOTANI, O.B. AND BOSE, G. 1973. Distribution of termites in relation to the ecology of the Indian Region. *Zool. Anz.*, 190 (3-4) : 231-236.

- CHHOTANI, O.B. AND BOSE, G. 1979a. Nesting behaviour and nests of Indian termites. *Zoologiana*, No. 2: 16-25, 4 pls.
- CHHOTANI, O.B. AND BOSE, G. 1979b. Insects of Saudi Arabia. Isoptera. *Fauna of Saudi Arabia*, 1: 75-83.
- CHHOTANI, O.B. AND BOSE, G. 1982. Insects of Saudi Arabia. Isoptera (Part 2). *Fauna of Saudi Arabia*, 4: 73-83.
- CHHOTANI, O.B. AND BOSE, G. 1983. Insects of Saudi Arabia. Isoptera (Part 3). Distribution of Isoptera and their affinities with the termites from the Indian Desert and neighbouring countries. *Fauna of Saudi Arabia*, 5: 121-128.
- CHHOTANI, O.B. AND BOSE, G. 1985a. *Isoptera of Saudi Arabia* (Part 4). *Fauna of Saudi Arabia*, 7: 121-124.
- CHHOTANI, O.B. AND BOSE, G. 1985b. Fauna of Namdapha : Arunachal Pradesh 'A proposed Biosphere Reserve' Insecta : Isoptera. *Rec. zool. Surv. India*, 82(1-4): 53-60.
- CHHOTANI, O.B. AND DAS, B.C. 1979. Variability in size and morphometric analysis of the soldier caste in *Heterotermes indicola* (Wasmann) (Rhinotermitidae : Heterotermitinae). *Zool. Surv. India Special Publ. (Proc. of Symposia)*, No. 1 : 47-52.
- CHHOTANI, O.B. AND DAS, B.C. 1983. A review of the Indian species of the genus *Reticulitermes* Holmgren (Isoptera : Rhinotermitidae). *Rec. zool. Surv. India*, 80(3-4) (1982) : 315-329.
- DESNEUX, J. 1902. Termites du Sahara Algerian recueillis par M. le professeur Lameere. *Ann. Soc. Ent. Belg.*, 46(10): 436-440.
- DESNEUX, J. 1904a (Mar. 29). Notes termitologiques. *Annls Soc. ent. Belg.*, 48(3): 146-151.
- DESNEUX, J. 1904b. A propos de la phylogenie des termitides. *Annls Soc. ent. Belg.*, 48(8): 278-286.
- DESNEUX, J. 1904c (Sept. 2). Trois termites nouveaux. *Annls Soc. ent. Belg.*, 48(8): 286-289.
- DESNEUX, J. 1904d (Nov. 10). Remarques critiques sur la phylogénie et la division systematique des termitides. (Réponse à M. Wasmann.) *Annls Soc. ent. Belg.*, 48(10): 372-378.

- DESNEUX, J. 1904e (Feb. 10). A new termite from India. *J. Bombay nat. Hist. Soc.*, 15(3): 445-446.
- DESNEUX, J. 1904f (Nov. 15). Isoptera, Family Termitidae. In *Genera Insectorum* (Ed. P. Wytsman), Fasc. 25: 52 pp., 2 pls.
- DESNEUX, J. 1906a (Jan. 25). Variétés termitologiques. *Annls Soc. ent. Belg.*, 49(12) (1905): 336-360.
- DESNEUX, J. 1906b. The Kashmir termite, *Termopsis wroughtoni*. *J. Bombay nat. Hist. Soc.*, 17(2): 293-298.
- DESNEUX, J. 1908 (Jan. 3). Variétés termitologiques. II Quelques especes nouvelles. *Annls Soc. ent. Belg.*, 51(12) (1907) : 388-400.
- DESNEUX, J. 1918. Un nouveau type de nids de termites. *Rev. Zool. Afr.*, 5(3) : 307.
- EMERSON, A.E. 1924. A new termite from the Juan Fernandez Islands (Swedish Exp. 1916-17). *Natural History Juan Fernandez and Easter Island*, 3(3) : 392-394.
- EMERSON, A.E. 1928. Le developement des soldats termites. *Annales Sci. nat. (Bot. et Zool.)*, (10) 11 : 261-284.
- EMERSON, A.E. 1933 (Mar. 31). A revision of the genera of fossil and recent Termopsinae (Isoptera). *Univ. Calif. Publ. (Ent.)*, 6(6) : 1 + 165-198.
- EMERSON, A.E. 1939. Report of the two cases of introduction of *Coptotermes*. (Typed note, 2 pp. *C. javanicus*, *C. havilandi*. Summary in *Rev. appl. Ent.*, (A)27 : 384(1939).
- EMERSON, A.E. 1942. The relations of a relic South African termite (Isoptera, Hodotermitidae, *Stolotermes*). *Am. Mus. Novit.*, No. 1187 : 1-12.
- EMERSON, A.E. 1952. The biogeography of termites. *Bull. Am. Mus. nat. Hist.*, 99 (Art. 3) : 217-225.
- EMERSON, A.E. 1955. Geographical origins and dispersions of termite genera. *Fieldiana (Zool.)*, 37 : 465-521.
- EMERSON, A.E. 1965. A review of the Mastotermitidae (Isoptera), including a new fossil genus from Brazil. *Am. Mus. Novit.*, No.2236 : 1-46.

- EMERSON, A.E. 1967. Cretaceous insects from Labrador 3. A new genus and species of termite (Isoptera : Hodotermitidae). *Psyche*, 74(4) 276-289.
- EMERSON, A.E. 1968. A revision of the fossil genus *Ulmeriella* (Isoptera, Hodotermitidae, Hodotermitinae). *Am. Mus. Novit.*, No. 2332 : 1-22.
- EMERSON, A.E. 1969. A revision of the tertiary fossil species of the Kalotermitidae (Isoptera). *Am. Mus. Novit.* No. 2359 : 1-57.
- EMERSON, A.E. 1971. Tertiary fossil species of the Rhinotermitidae (Isoptera), phylogeny of genera and reciprocal phylogeny of associated Flagellata (Protozoa) and the Staphylinidae (Coleoptera). *Bull. Am. Mus. nat. Hist.*, 146(Art. 3) : 243-303.
- EMERSON, A.E. AND KRISKNA, K. 1975. The termite family Serritermitidae (Isoptera). *Am. Mus. Novit.*, No. 2570 : 1-31.
- ENDERLEIN, G. 1909. Die klassifikation der Embiidinen nebst morphologischen and physiologischen Bemerkungen besonders über das Spinnen derselben. *Zool. Anz.*, 35(6) : 166-191.
- ESCHERICH, K. 1911. *Termitenleben auf Ceylon. Neue Studien zur Soziologie der Tiere zugleich ein Kapitel kolonialer Forstentomologie.* (Mit einem systematischen Anhang mit Beiträgen von A. Forel, Nils Holmgren, W. Michaelson, F. Schimmer, F. Silvestri and E. Wasmann.) xxxii + 263 pp., 3 pls. Jena (Gustav Fischer).
- FERNANDO, H.E. 1962. Termites of economic importance in Ceylon. In *Termites in Humid Tropics* (Proc. New Delhi Sympos., 1960) : 205-210. Paris (Unesco).
- FLETCHER, T.B. 1912. Termites or white ants. *Agric. J. India*, 7(3) : 219-239, 3 pls.
- FLETCHER, T.B. 1914. *Some South Indian Insects and Other Animals of Importance Considered Especially from an Economic Point of View*, xxi + 565 pp., 50 pls. Madras. (Govt. Press). (Reprinted 1984, Dehra Dun; Bishen Singh, etc.)
- FLETCHER, T.B. 1916. One hundred notes on Indian insects. 100. *Coptotermes gestroi* in India. *Bull. agric. Res. Inst. Pusa*, No. 59 : v + 39 pp.

- FLETCHER, T.B. (Ed. by). 1917. Reports of the Proceedings of the Second Entomological Meeting held at Pusa on 5th - 12th Feb. 1917. xii + 340 pp., 1 frontis - p., 34 col. pls. Calcutta (Govt. India Press).
- FLETCHER, T.B. 1920. Annotated list of Indian crop pests. *Rept. Proc. 3rd ent. Mtg. Pusa (3rd - 15th Feb. 1919)*. 1 33-314, 7 pls.
- FLETCHER, T.B. 1921. Koenig's paper on South Indian termites. (Translated from German into English, and discussed). *Proc. 4th ent. Mtg. Pusa. Calcutta*, pp. 312-333, 6 pls. (Also includes a note on the life of Koenig; a translation of Koenig's paper of 1779: and several original Fletcher's photos of mounds and observations on South Indian termites. Also see KOENIG, J.G. 1779.
- FROGGATT, W.W. 1895. Australian Termitidae. Pt. II. *Proc. Linn. Soc. N.S.W.*, 10: 415-438; 1896, Pt. II, *ibid*, 21 : 510-552; 1897, Pt. III, *ibid*, 22: 721-758.
- FULLER, C. 1915. Observations on some South African termites. *Ann. Natal. Mus.*, 3(2) : 329-505, 11 pls.
- FULLER, C. 1924. The thorax and abdomen of winged termites, with special reference to the sclerites and muscles of the thorax. *Ent. Mem. Dept. Agric. S. Afr.*, No. 2 : 49-78, 3 pls.
- GAO, D. 1984. The genus *Glyptotermes* (Isoptera : Kalotermitidae) from China : with a description of a new species. (In Chinese with English summary). *J. Nanjing Inst. Forestry*, No. 4 : 53-60.
- GAO, D. AND MA, X. 1983. Studies on the termites from Sichuan. IX. Description on (sic!) imagoes of two species (*Lobitermes emei* and *Glyptotermes hesperus*). (In Chinese with English summary.) *Zool. Res.*, 4(2) : 135-138.
- GAO, D., PAN, Y., MA, X. AND SHI, W. 1982 (Dec.). Notes on the genus *Reticulitermes* from Sichuan, China, with descriptions of new species. (In Chinese with English summary.) - *Entomotaxonomia*, Peking, 4(4) : 299-306.
- GARDNER, J.C.M. 1945 (June 30). New Termitidae from India and Burma (Isoptera). *Indian J. Ent.*, 6(1-2) (1944) : 103-110.
- GAY, F.J. 1967. A world review of introduced species of termites. *Bull. Commonw. sci. ind. Res. Organis. (Austral.)*, No. 286 : 1-88.

- GAY, F.J. 1969. Species introduced by man. In *Biology of Termites* (Ed. by K. Krishna and F.M. Weesner), Vol. 1, pp. 459-494. New York and London (Academic Press.)
- GEYER, J.W.C. 1951. The reproductive organs of certain termites, with notes on the hermaphrodites of *Neotermes*. *Ent. Mem. Dept. Agric. Un. S. Afr.*, 2(9): 2 + 233-325.
- GRASSÉ, P.-P. 1937. Mission de l' Omo le *Bellicositermes jeaneli* n. sp. Constructeur de grandes termitières à cheminee. *Bull. Soc. Ent. France*, 42(5) : 71-73.
- GRASSÉ, P.-P. 1949. Order des isoptères ou termite. (Isoptera Brullé 1852). In *Traite de Zoologie*, (Ed. P.P. Grassé), Vol. IX, *Insectes* : 408-544. Paris (Masson and Cie).
- GRASSÉ, P.-P. 1982. *Termitologia. Anatomie, Physiologie, Biologie, Systematique des Termites*. Vol. I. *Anatomie, Physiologie, Reproduction*. xiv + 676 pp. Paris (Masson).
- GRASSÉ, P.-P. 1984. *Termitologia, Anatomie, Physiologie, Biologie, Systematique des Termites*. Vol. II *Fondation des Societes, Construction*. ix + 1 + 613 pp. Paris (Masson).
- GRASSÉ, P.-P. 1986. *Termitologia, Anatomie, Physiologie, Biologie, Systematique des Termites*. Vol. III. xi + 1 + 715 pp. Paris (Masson).
- GRASSÉ, P.P. AND NOIROT, C. 1954. *Apicotermes arquieri* (Isoptere) : Ses constructions, sa biologie. Considérations general sur la sous-famille des Apicotermitinae nov. *Annls Sci. nat. (Zool.)*, (11) 16: 345-388, 5 pls.
- GRASSI, B. AND SANDIAS, A. 1893. Costituzione e sviluppo della società dei termitidi. Osservazione sui loro costumi, con un' appendice sui Protozoi parassiti dei termitidi e sulla famiglia delle Embidine. [Part 1.] *Atti Accad. Gioen. Sci. nat. Catania*, (4)6(13): 1-75, 2 pls. (English transl. by W.F.H. Blanford in *Q. Jl. micros. Sci.*, (N.S.), 39: 245-322, 5 pls., 1896.)
- GRASSI, B. AND SANDIAS, A. 1894. Ditto. [Part. 2.] *Atti Accad. Gioenia Sci. nat. Catania*, (4) 7(1): 1-76, 3 pls. (English transl. by W.F.H. Blanford in *Q. Jl. micros. Sci.*, (N.S.), 40: 1-82, 3 pls., 1897.)

- GREEN, E.E. 1913 (June). Catalogue of Isoptera (termites) recorded from Ceylon. *Spolia Zeylan.*, 9(33): 7-15.
- GRIFFIN, F.J. 1951. A bibliography of the Isoptera (termites) 1758-1949. *J. Soc. Bibliogr. nat. Hist.*, 2(8): 261-368.
- GUPTA, S.D. 1962a. Morphology of the primitive termite, *Anacanthotermes macrocephalus* (Desneux) (Isoptera : Hodotermitidae). Part 1. External morphology of the soldier caste. *Rec. Indian Mus.*, 58(3-4) (1960) : 169-194.
- GUPTA, S.D. 1962b. Morphology of the primitive termite, *Anacanthotermes macrocephalus* (Desneux) (Isoptera : Hodotermitidae). Part 2. External morphology of the alate and worker castes. *Rec. Indian Mus.*, 58(3-4) (1960) : 195-222.
- HAGEN, H.A. 1852. Über die Lebensweise der Termiten und ihre Verbreitung. *Königsb. naturw. Unterhalt.*, 2(3): 53-75.
- HAGEN, H.A. 1853. Hr. Peters berichtete über die von ihm gesammelten und von Hrn. Dr. Herman Hagen bearbeiteten Neuropteren aus Mosambique. *Ber. Königl. preuss. Akad. Wissens.*, 1853 : 479-482.
- HAGEN, H.A. 1855. Monographie der Termiten. [Part 1.] *Linn. ent.*, 10: 1-144; and 270-325.
- HAGEN, H.A. 1858a. Monographie der Termiten. Part 2. *Linn. ent.*, 12: 1-342, 3 pls.; and 459 (errata).
- HAGEN, H.A. 1858b. *Catalogue of the Specimens of Neuropterous Insects in the Collection of the British Museum. Part I. Termitina.* 34 pp. London (Brit. Mus. Nat. Hist.).
- HAGEN, H.A. 1858c. Synopsis der Neuroptera Ceylons. [Part 1.] *Verh. zool. bot. Ges. Wien.*, 8: 471-478.
- HAGEN, H.A. 1859. Synopsis der Neuroptera Ceylons [Part 2.] *Verh. zool. bot. Ges. Wien.*, 9: 199-212.
- HAGEN, H.A. 1860a. Monographie der Termiten. [Part 3.] *Linn. Ent.*, 15: 73-99.
- HAGEN, H.A. 1860b. Nachtrag zur Monographie der Termiten. *Linn. Ent.*, 15: 100-128.

- HARE, L. 1937. Termite phylogeny as evidenced by soldier mandible development. *Ann. ent. Soc. Am.*, 30(3) 459-486, 13 pls.
- HARRIS, W V 1957. An introduction to Malayan termites. *Malay. Nat. J.*, 12: 20-32, 1 pl., Also in *Malay. Forester*, 21: 87-97, 1 pl.
- HARRIS, W V 1961. *Termites: Their Recognition and Control*. xii + 187 pp., sev. pls. (8 col.), 1 fldg. chart. London (Longmans, Green & Co.).
- HARRIS, W V 1963. The termites of Hong Kong. *Mem. Hong Kong nat. Hist. Soc.*, No. 6: 1-9.
- HARRIS, W.V 1966. Type localities of the Isoptera described by Haviland. *Proc. Linn. Soc. Lond.*, 117: 11-17.
- HARRIS, W. V 1967a. Beitrage zur Kenntnis der Fauna Afghanistans. (Sammelergebnisse von O. Jzkes 1963-64, D. Povolny 1965, D. Povolny and Fr. Tenora 1966, J. Simek 1965-66.) Isoptera. *Acta Mus. Moraviae (Sci. nat.)*, 52 (Suppl.) 211-215.
- HARRIS, W V 1967b. Termites of the genus *Anacanthotermes* in North Africa and the Near East (Isoptera: Hodotermitidae). *Proc. R. ent. Soc., Lond.*, (B) 36(5-6): 79-86.
- HARRIS, W. V. 1968. Isoptera from Vietnam, Cambodia and Thailand. *Opusc. Ent.*, 33(1-2) : 143-154.
- HARRIS, W. V. 1970. Termites of the Palearctic Region. In *Biology of Termites* (Ed. by K. Krishna and F.M. Weesner), Vol. 2, pp. 295-313. New York and London (Academic Press).
- HAVILAND, G.D. 1894. [Note on habits of termites of Singapore.] *Proc. ent. Soc. Lond.*, 1894 : viii.
- HAVILAND, G.D. 1898. Observations on termites, with descriptions of new species. *J. Linn. Soc. Lond. (Zool.)*, 26 (169): 358-442.
- HAVILAND, G.D. 1901-1902. Observations on termites or white ants. *Annual Rept. Smithson. Inst.*, Washington, pp. 667-678, 4 pls. (Summary from Haviland, *J. Linn. Soc., Lond. (Zool.)*, 26, pp. 358-442, 1898, supra.)
- HAVILAND, G.D. AND SHARP, D. 1896. Termites in captivity in England. *Trans. ent. Soc. London*, 1896: 589-594.

- HE, X. S. AND XIA, K.L. 1981. New genus of termites related to *Indotermes* from China [Isoptera : Termitidae.] *Contrib. Shanghai Inst. Ent.* 1981 : 197-204.
- HEBERDEY, R.F. 1931. Zur Entwicklungsgeschichte vergleichende Anatomie und Physiologie der weiblichen Geschlechtsausfuhrwege der Insekten. *Z. Morph. Ökol. Tiere*, 22: 416-586.
- HEGH, E. 1922. *Les Termites. Partie Générale. Description. Distribution Géographique. Classification. Biologie. Vie Sociale. Alimentation. Construction. Reports avec le Monde extérieur.* 4 + 756 pp., 1 flgd. chart. Brussels (Louis Desmet-verteneuil) (Republished, with additions, in *Bull. Agric. Congo. Belge.*, 1920-1923, Vols. 11, 12, 13 and 14.)
- HILL, G.F. 1915. Northern Territory Termitidae. *Proc. Linn. Soc. N.S.W.*, 40(1) : 83-113, 10 pls.
- HILL, G.F. 1921. New and rare Australian termites with notes on their biology. *Proc. Linn. Soc. N.S.W.*, 46(4) 443-456, 1 pl.
- HILL, G.F. 1925. Termites from the Australian Region, descriptions of new species and hitherto undescribed castes. *Proc. Roy. Soc. Victoria (N.S.)*, 37(2) : 206-229, 4 pls.
- HILL, G.F. 1933. Australian *Rhinotermes*. *Proc. Roy. Soc. Victoria (N.S.)*, 44(1) : 1-17, 4 pls.
- HILL, G.F. 1942. *Termites (Isoptera) from the Australian Region (including Australia. New Guinea and Islands South of the Equator between 140° E longitude and 170° W Longitude.* 4 + 479. pp., 24 pls. Melbourne (Counc. sci. ind. Res. Commonw. Austral.).
- HOLMGREN, K. AND HOLMGREN, N. 1917 (Aug.). Report on a collection of termites from India. *Mem. Dept. Agric. India (Ent.)*, 5(3) : 137-171. [With notes on synonymy by T.B. Fletcher.]
- HOLMGREN, N. 1906. Studies über Südamerikanische Termiten. *Zool. Jb. (Syst.)*, 23(5) : 521-676.
- HOLMGREN, N. 1909 (July 15). Termitenstudien. 1. Anatomische Untersuchungen. *K. svenska Vetenskakad. Handl.*, 44(3) : 1-215, 3 pls.
- HOLMGREN, N. 1910. Das system der Termiten. *Zool. Anz.*, 35 : 284-286.

- HOLMGREN, N. 1911a. *Om Termiter och myrov. En. Inblick i Sociala Insekters Biology.* 286 pp. Stockholm (Vetenskap och bildning, Bd. 11).
- HOLMGREN, N. 1911b. Ceylon-Termiten gesammelt von Prof. K. Escherisch, nebst einer synoptischen übersicht über alle bis jetzt von Ceylon und den angrenzenden Festland bekannten Termitenarten. In *Termitenleben auf Ceylon, u.s.w.* (by K. Escherisch). Systematischer Anhang : Termiten und Termitophilen von Ceylon, pp. 183-212, 2 pls. Jena (Gustav Fischer).
- HOLMGREN, N. 1911c (July 26). Termitenstudien. 2 Systematik der Termiten. *K. svenska VetenskAkad. Handl.*, **46**(6) : 1-86, 6 pls.
- HOLMGREN, N. 1911d (June 13). Bemerkungen über einige Termiten Arten. *Zool. Anz.*, **37**(26) : 545-553.
- HOLMGREN, N. 1912a (May 20). Termitenstudien. 3. Systematik der Termiten. Die Familie Metatermitidae. *K. svenska VetenskAkad. Handl.*, **48**(4) : 1-166, 4 pls.
- HOLMGREN, N. 1912b (July 30). Termites from British India (Bombay) collected by Dr. J. Assmuth. *J. Bombay nat. Hist. Soc.*, **21**(3) : 774-793, 4 pls.
- HOLMGREN, N. 1913a (Apr. 21). Termites from British India (near Bombay, in Gujarat and Bangalore) collected by Dr J. Assmuth S. J. Part II. *J. Bombay nat. Hist. Soc.*, **22**(1) : 101-117, 3 pls.
- HOLMGREN, N. 1913b (May 23). Termitenstudien. 4. Versuch einer Systematischen Monographie der Termiten der orientalischen Region. *K. svenska VetenskAkad. Handl.*, **50**(2) : 1-276, 8 pls.
- HOLMGREN, N. 1913c (June 30). Termiten aus Java und Sumatra gesammelt von Edward Jacobson. *Tijds. Ent.*, **56** : 13-28, 2 pls.
- HOLMGREN, N. 1914a (Jan.). On some termites collected by Mr. Green in Ceylon. *Spolia zeylan.*, **8** (32) (1913) : 277-284
- HOLMGREN, N. 1914b (Feb. 9). Wissenschaftliche Ergebnisse einer Forschungsreise nach Ostindien, ausgeführt im Auftrage der Kgl. Preuss. Akademie der Wissenschaften zu Berlin von H. v. Buttel-Reepen. III. Termiten aus Sumatra, Java, Malacca und Ceylon. Gesammelt von Herrn Prof, Dr. v. Buttel-Reepen in den Jahren 1911-1912. *Zool. Jb. (Syst.)*, **36**(2-3) : 228-290, 7 pls.

- HOZAWA, S. 1915. Revision of Japanese termites. *J. College Sci. imp. Univ. Tokyo*, **35** : 1-161.
- HSIA, K.L. AND FAN, S.T. 1970. Notes on the genus *Reticulitermes* Holmgren of China (Isoptera, Rhinotermitidae). *Acta ent. Sinica*, **3** (1968) : 51-75.
- HUTSON, J.C. 1923a. Notes on termites attacking tea in Ceylon. *Trop. Agric.*, **60**(2) : 83-87.
- HUTSON, J.C. 1923b. Notes on termites attacking tea in Ceylon. *Trop. Agric.*, **60**(5) : 291-298, 2 pls.
- IKEHARA, S. 1966. Distribution of termites in the Ryukyu Archipelago. *Bull. Arts Sci. Div. Univ. Ryukyus*, No. 9 : 49-176, 3 pls.
- IMMS, A.D. 1919 (Sept. 19). On the structure and biology of *Archotermopsis*, together with descriptions of new species of intestinal Protozoa, and general observations on the Isoptera. *Philos. Trans. R. Soc.*, (B)**209** : 75-180, 8 pls.
- IMMS, A.D. 1930. *A General Text-book of Entomology. Including the Anatomy. Physiology. Development and Classification of Insects.* (2nd Ed., revised.) x + 703 pp. London (Methuen and Co.).
- IMMS, A.D. 1957. *A General Text-book of Entomology. Including the Anatomy. Physiology. Development and Classification of Insects.* (9th Ed., revised by C.W. Richards and R.G. Davies). x + 886 pp. London (Methuen and Co.).
- JACOBSON, G.G. 1905. Zur Kenntnis der termiten Russlands. *Ann. Mus. zool. Acad. imp. Sci.*, St. Petersburg, **9**(1904) : 57-107. With a section on biology of *Hodotermes vagans septentrionalis*, by J.W. Wassieljew, pp. 97-103.
- JEPSON, F.P. 1927. A preliminary note on the distribution of the Ceylon tea *Calotermes*. *Yearbk. Dept. Agric. Ceylon*, 1927 : 19-21, 1 pl.
- JEPSON, F.P. 1930. Termites attacking *Hevea brasiliensis* in Ceylon. *Trop. Agric.*, **75**(3) : 143-156, 5 pls.
- JOHN, O. 1913 (Oct.). Notes on some termites from Ceylon. *Spolia zeylan.*, **9**(34) : 102-116.
- JOHN, O. 1925 (Dec.). Termiten von Ceylon, der Malayischen Halbinsel, Sumatra, Java und den AruInseln. *Treubia*, **6**(3-4) : 360-419, 8 pls.

- JOHNSON, R.A. 1979. Configuration of the digestive tube as an aid to identification of worker Termitidae (Isoptera). *Syst. Ent.*, 4 : 31-38.
- JONES, S.C., LA FAGE, J.P. AND HOWARD, R.R. 1982. Isopteran sex-ratio strategies. In *The Biology of Social Insects (Proc. 9th Congr. int. Un. soc. Ins., Boulder, Aug. 1982)* (Ed. by M.D. Breed, C. Mitchner and H.E. Evans) : 406. Boulder (Westview Press).
- KEMNER, N.A. 1925a. Zwei neue chinesische Termiten aus der Sammelbeute der Kolthoffschen Expedition nach China 1921-1922. *Ark. Zool.*, (A) 17(28) : 1-6.
- KEMNER, N.A. 1925b. Larva termitovorax, eine merkwürdige parasitische Fliegenlarve, die im Kopfe von Termitensoldaten lebt, und durch die Verunstaltung desselben Veranlassung zur Aufstellung eines besonderen Termitengenus mit zwei Arten gegeben hat. *Ark. Zool.*, (A) 17(29): 1-15, 1 pl.
- KEMNER, N.A. 1926a. Some termites from Ceylon. *Bull. ent. Res.*, 16(4): 397-392.
- KEMNER, N.A. 1926b. Über die Zucht der Larve einer echten *Termitoxenia*. *Verh. III. int. Ent. Kongr.* (Zurich, 1925), 2: 389-404, 1 pl.
- KEMNER, N.A. 1926c. Über die Zucht von einer 'larva Eutermia' aus Java und das Ausschlüpfen aus derselben der physogastren Aleocharide *Affinoptochus excleusus* n. g., n. sp. *Ark. Zool.*, (A) 18 (10): 1-24, 2 pls.
- KEMNER, N.A. 1929a. Aus der Biologie der Termiten Javas. *C.R. X Congr. int. Zool.* (Budapest, 1927), 2: 1097-1117.
- KEMNER, N.A. 1929b. Entomologische Ergebnisse einer Reise nach Ostasien (H. Eidmann). Isoptera. *Verh. zool.-bot. Ges. Wien*, 79(2-4): 323.
- KEMNER, N.A. 1930. Fauna Sumatrensis. Bijdrage No. 66. Termitidae. *Tijds. Ent.*, 73(3-4): 298-324.
- KEMNER, N.A. 1931. Die Termitenfauna von Amboina. Ergebnisse der Sunda-Expedition der Notgemeinschaft der deutschen Wissenschaft, 1929-30. (Mitteilungen von Dr. F. Weyer). *Lund Univ. Arsskrift*, (N.F.), (2) 27 (13): 1-53, 2 pls. Also as *Kungl. fysiografiska Sällskapets Handl.*, 42(13): 1-53, 2 pls.

- KEMNER, N.A. 1932a. Zur Kenntnis der Javanischen Termitoxenen, mit Bemerkungen über ihre Morphologie und Biologie. *Ent. Tijds.*, 53 (1): 17-29, 3 pls.
- KEMNER, N.A. 1932b. Neue Termiten aus der orientalischen Region. I-II. *Ent. Tijds.*, 53 (2): 133-155.
- KEMNER, N.A. 1933. Resultats scientifiques du voyage aux Indes Orientales néerlandaises de LL. A.A. R.R. le Prince et la Princesse Leopold de Belgique. Isoptera. *Mem. Mus. Roy. Hist. nat. Belg.*, 4(8) (Hors serie) : 17-30, 1 pl.
- KEMNER, N.A. 1934 (Mar. 6). Systematische und biologische Studien über die Termiten Javas und Celebes. *K. svenska VetenskAkad. Handl.*, (3) 13(4): 1-241, 22 pls.
- KEMNER, N.A. 1936. Zur näheren Kenntnis der *Termitoxenia jägerskioldi* Wasm. als Typus eines neuen Genus der Termitoxenien. *Opusc. Ent.*, 1(2): 35-39.
- KEMNER, N.A. 1943. Ein Blick auf Termiten Javas und Celebes. *Jb. dtsh. Auslandsamtes d. deutsch. Dozentenschaft*, 1943: 50-53.
- KHAN, M.A. AND AHMAD, M. 1954. Termites of Lahore. *Proc. 6th Pakistan Sci. Conf. (Abstr.)*: 140.
- KHAN, M.A. AND AHMAD, M. 1955. (June). The imago of *Kaloterme beelsoni* (Isoptera, Kalotermitidae). *Biologia(Lahore)*, 1(1) : 28-30.
- KISTNER, D.H. 1969. The biology of termitophiles. In *Biology of Termites* (Ed. by K. Krishna and F.M. Weesner), Vol. 1 : 525-557. New York (Academic Press).
- KOENIG, J.G. 1979. See KÖNIG, J.G. 1779.
- KOFOID, C.A.(Ed. by) 1934 (Jan.). *Termite and Termite Control. A Report to the Termite Investigations Committee.* xxv + 734 pp., 1 frontp. Berkeley(Calif. Univ. Press) and London (Cambridge Univ. Press). (2nd Ed., Dec. 1934.)
- KOFOID, C.A. (Ed. by). 1946. Ditto. (2nd Ed., 2nd printing). 4 + xxvi + 795 pp., 1 frontp. Berkeley (Calif. Univ. Press).

- KÖNIG, J.G. 1779. Naturgeschichte der sogenannten weissen Ameisen. *Beschr. berlin. Ges. Naturf. Freunde* : 4 : 1-28. English translation and comments, by T.B. Fletcher, in *Proc. 4th ent. Meeting (Pusa. 1921)*, 4 312-333, 6 pls., 1921; see T.B. Fletcher, 1921 above.
- KRISHNA, K. 1961. A generic revision and phylogenetic study of the family Kalotermitidae (Isoptera). *Bull. Am. Mus. nat. Hist.*, 122 303-408.
- KRISHNA, K. 1965. Termites (Isoptera) of Burma. *Am. Mus., Novit.*, No. 2210 1-34.
- KRISHNA, K. 1969. Introduction. In *Biology of Termites* (Ed. by K. Krishna and F.M. Weesner), Vol. 1 1-17. New York and London (Academic Press).
- KRISHNA, K. 1970. Taxonomy, phylogeny and distribution of termites. In *Biology of Termites* (Ed. by K. Krishna and F.M. Weesner), Vol.2 127-152. New York and London (Academic Press)
- KRISHNA, K. AND WEESNER, F.M. (Ed. by). 1969. *Biology of Termites*. Vol. 1 xii + 598 pp. New York and London (Academic Press).
- KRISHNA, K. AND WEESNER, F.M. (Ed. by). 1970. *Biology of Termites*. Vol. 2 xiv + 1 + 643 pp. New York and London (Academic Press).
- KUSHWAHA, K. S. 1959. Chaetotaxy of the soldier, worker and alate of the termite *Odontotermes obesus* (Rambur). *Curr. Sci.*, 28(10) 415-417.
- KUSHWAHA, K.S. 1960a. External morphology of the termite, *Odonotermes obesus* (Rambur) (Isoptera : Termitidae). Part 1. Soldier. *Rec. Indian Mus.*, 54(3&4) (1956) : 209-227.
- KUSHWAHA, K.S. 1960b. External morphology of the termite, *Odonotermes obesus* (Rambur) (Isoptera : Termitidae). Part 2. Alate and worker. *Rec. Indian Mus.*, 54(3-4) (1956) : 229-250.
- KUSHWAHA, K.S. 1960c. Chaetotaxy of the termite, *Odontotermes as-smuthi* Holmg. (Isoptera : Termitidae). Part I. Soldier. *Proc. Indian Acad. Sci.*, (B)52 54-65.
- KUSHWAHA, K.S. 1960d. Chaetotaxy of the termite, *Odontotermes as-smuthi* Holmgren (Isoptera Termitidae). Part II. Worker. *Proc. Indian Acad. Sci.*, (B)54 : 130-137.

- KUSHWAHA, K.S. 1962a. Taxonomic differentiation in three species of *Odontotermes* (Isoptera, Termitidae) as based on chaetotaxy. In *Termites in the Humid Tropics* (Proc. New Delhi Sympos., 1960) : 55-62, Paris (Unesco).
- KUSHWAHA, K.S. 1962b. External morphology of the termite, *Odontotermes obesus* (Rambur) (Isoptera : Termitidae). Part 3. Chaetotaxy of the soldier, worker and alate castes. *Rec. Indian Mus.*, **58**(2) (1960) : 71-114, 5 pls.
- LAHIRI, A.R. AND GHOSH, A.K. 1980. Termites of Manipur, India, with new records (Insecta : Isoptera). *Rec. zool. Surv. India*, **76** : 65-70.
- LAHIRI, A.R., GHOSH, A.K. AND BISWAS, S. 1977. A preliminary study of insect fauna of Meghalaya. 11. Isoptera : Four new records and notes on other species. *Bull. Meghalaya Sci. Soc.*, **2** : 35-38.
- LAL, RATTAN. See RATTAN LAL.
- LATREILLE, P.A. 1795. Extrait d'un memoirs pour servir de suite a l'histoire des *Termes*, ou fourmis blanches. *Bull. Sci. Soc., Philom.*, **1** : 84-85.
- LATREILLE, P.A. 1804, *Termes Termes*. *N. Diet. Hist. nat.*, **22** : 49-63.
- LEFROY, H.M. 1906. *Indian Insect Pests*. vii + 318 pp. Calcutta (Govt. of India). (Reprinted 1971, New Delhi, Today and Tomorrow's Printers, etc.)
- LEFROY, H.M. 1909. *Indian Insect Life. A Manual of the Insects of the Plains (Tropical India)*. xii + 786 pp., 84 pls. Calcutta & London. (Thacker Spink & Co.) (Reprinted 1971, New Delhi, Today and Tomorrow's Printers, etc.).
- LESPES, C. 1856. Recherches sur l'organisation et le moeurs du termite lucifuge. *Annals Sci. nat. (Zool.)*, **(4)5** : 227-282.
- LI, G. AND PING, Z. 1983. Description of a new genus *Tsaitermes* and its three new species from China (In Chinese). *Entomotaxonomia*, **5** : 239-246.
- LIGHT, S.F. 1921a (Mar.) Notes on Philippine termites. I. *Philipp. J. Sci.*, **18**(3) : 243-257.
- LIGHT, S.F. 1921b (July). Notes on Philippine termites. II. *Philipp. J. Sci.*, **19**(1) : 23-64, 6 pls.

- LIGHT, S.F. 1924. The termites (white ants) of China, with description of six new species. *China J. Sci. & Arts.*, 2(1-4) : 50-60; 140-142; 242-254; and 354-358.
- LIGHT, S.F. 1929. Notes on Philippine termites. III. *Philipp. J. Sci.*, 40(4) 421-452, 8 pls.
- LIGHT, S.F. 1930 (May). Notes on Philippine termites. IV. *Philipp. J. Sci.*, 42(1) 13-58, 8 pls.
- LIGHT, S.F. 1931. Present status of our knowledge of the termites of China. (With an Appendix, p. 600, on : Instructions for preparation of slides of Protozoa of termites for study.) *Lignan Sci. J.*, 7(1929) 581-600.
- LIGHT, S.F. 1934a. A world view of termites. In *Termites and Termite Control* (Ed. by C.A. Kofoid) (2nd Ed.) : 108-117. Berkeley (Univ. Calif. Press).
- LIGHT, S.F. 1934b. Habitat and habit types of termites and their economic significance. In *Termites and Termite Control* (Ed. by C.A. Kofoid) (2nd Ed.) : 127-140. Berkeley (Univ. Calif. Press).
- LIGHT, S.F. 1934c. Dry-wood termites, their classification and distribution. In *Termites and Termite Control* (Ed. by C.A. Kofoid) (2nd Ed.) : 197-200. Berkeley (Univ. Calif. Press).
- LIGHT, S.F. 1934d. Termites and growing plants. In *Termites and Termite Control* (Ed. by C.A. Kofoid) (2nd Ed.) : 286-292. Berkeley (Univ. Calif. Press.).
- LIGHT, S.F. 1934e. The termite fauna of the Philippine Islands and its economic significance. In *Termites and Termite Control* (Ed. by C.A. Kofoid) (2nd Ed.): 319-322. Berkeley (Univ. Calif. Press).
- LIGHT, S.F. 1937. Contributions to the biology and taxonomy of *Kaloterme (Paraneoterme) simplicicornis* Banks (Isoptera). *Univ. Calif. Publ. (Ent.)*, 6(16) : 423-463, 3 pls.
- LIGHT, S.F. 1937. (Jan. - Apr.). A collection of termites from Ceylon and Java. *Pan-Pacific Ent.*, 13(1-2) : 15-24.
- LIGHT, S.F. 1946a. A world view of termites. In *Termites and Termite Control*. (Ed. by C.A. Kofoid) (2nd Ed. rev.) : 117-126. Berkeley (Univ. Calif. Press).

- LIGHT, S.F. 1946b. Habitat and habit types of termites and their economic significance. In *Termites and Termite Control* (Ed. by C.A. Kofoid) (2nd Ed., rev.) 136-149. Berkeley (Univ. Calif. Press).
- LIGHT, S.F. 1946c. Dry-wood termites, their classification and distribution. In *Termites and Termite Control*. (Ed. by C.A. Kofoid) (2nd Ed., rev.) : 206-209. Berkeley (Univ. Calif. Press).
- LIGHT, S.F. 1946d. Termites and growing plants. In *Termites and Termite Control*. (Ed. by C.A. Kofoid) (2nd Ed., rev.) 314-320. Berkeley (Univ. Calif. Press).
- LIGHT, S.F. 1946e. The termite fauna of the Philippine Islands and its economic significance. In *Termites and Termite Control* (Ed. by C.A. Kofoid) (2nd Ed. rev.) 347-350. Berkeley (Univ. Calif. Press).
- LIGHT, S.F. AND WILSON, F.J. 1936 (Aug.). The nasute termites of the Philippines. *Philipp. J. Sci.*, **60**(4) : 461-520.
- LINNAEUS, C. 1758. *Systema Naturae per Regna Tria Naturae*. (Ed. 10), Vol. 1.
- LINNAEUS, C. 1778-93. *Systema Naturae*. (Ed. 13, aucta, reformatacura Joh. Friedr. Gmelin) Vol. 1, pt. 5.
- MAITI, P.K. 1975 (July). Two new species of termites (Isoptera) from West Bengal, India. *Orient. Insects*, **9**(2): 139-148.
- MAITI, P.K. 1976 (Nov. 10). A new species of termite of the genus *Glyptotermes* Froggatt (Isoptera : Kalotermitidae) from India. *Proc. zool. Soc.*, **27**(2) (1974) 117-122.
- MAITI, P.K. 1977. The geographical origin, dispersion and evolution of termites (Isoptera) of the Andaman and Nicobar Islands, Indian Ocean. *Abstrs. 2nd Orient. Ent. Sympos.* (Madras, Mar. 1977): 54.
- MAITI, P.K. 1978. Investigation on the seasonal variation, population estimation and some aspects of bioecology of *Cryptotermes havilandi* (Sjöst.) (Isoptera) in West Bengal. *Abstrs. Sympos. Ecol. of anim. Popul.* (Calcutta, Oct. 1978) : 69.
- MAITI, P.K. 1979b. The composition and geographical origin of the termites (Isoptera) of the Great Nicobar Island, Indian Ocean. *Proc. zool. Soc.*, **30**(1-2) (1977) : 131-135.

- MAITI, P.K. 1981. Faunal zones and bioecological notes on the soil-inhabiting termites (Isoptera) of West Bengal, India. In *Progress in Soil Biology and Ecology in India* (Ed. by G.K. Veeresh) 265. Bangalore (Univ. Agric. Sci.).
- MAITI, P.K. 1983. Termite fauna (Isoptera) of West Bengal, India. Their recognition, biology and ecology. *Occ. Pap. Rec. zool. Surv. India*, No. 42: iv + 152, 4 figd. maps.
- MAITI, P.K. AND CHAKRABORTY S.K. 1981 (Oct. 31). Two new termites of genus *Glyptotermes* (Kalotermitidae) from the Great Nicobar Island, Indian Ocean. *Bull. zool. Surv. India*, 4 (1) 91981): 71-84.
- MARGABANDHU, V 1934 (Dec. 15). An annotated list of Indo-Ceylonese termites. *J. Bombay nat. Hist. Soc.*, 37(3): 700-714.
- MARGABANDHU, V 1935 (Aug. 15). An annotated list of Indo-Ceylonese termites. [Additions.] *J. Bombay Nat. Hist. Soc.*, 38(1): 208-209.
- MATHUR, R.N. AND CHHOTANI, O.B. 1959. Revision of *Stylotermes* Holmgren and Holmgren (Isoptera . Rhinotermitidae : Stylotermitinae). *Zool. Anz.*, 163(1/2) : 40-53.
- MATHUR, R.N. AND CHHOTANI, O.B. 1969 (Oct.). Two new termites of the genera *Coptotermes* Wasmann and *Heterotermes* Froggatt (Rhinotermitidae) from India. *J. Timber Devel. Assoc. India*, 15(4): 1-10.
- MATHUR, R.N. AND SEN-SARMA, P.K. 1958. A new species of *Anacanthotermes* from South India (Insecta Isoptera Hodotermitidae). *Entomologist*, 91: 233-241, 4 pls.
- MATHUR, R.N. AND SEN-SARMA, P.K. 1959. Notes on the habits and biology of Dehra Dun termites. [Part 1.] *J. Timber Dryers and Preserv. Assoc. India*, 5(3): 3-9, 2 pls.
- MATHUR, R.N. AND SEN-SARMA, P.K. 1960a. *Glyptotermes nigrifrons* sp. n. from South India (Insecta : Isoptera Kalotermitidae). *Entomologist*, 93: 79-85.
- MATHUR, R.N. AND SEN-SARMA, P.K. 1960b. Notes on the habits and biology of Dehra Dun termites [Part 2.] *J. Timber Dryers & Preserv. Assoc. India*, 6(2): 23-27.

- MATHUR, R.N. AND SEN-SARMA, P.K. 1962. Notes on the habits and biology of Dehra Dun termites. Part 3. *J. Timber Dryers & Preserv. Assoc. India*, **8**(1): 1-18, 2 pls.
- MATHUR, R.N. AND THAPA, R.S. 1962a. A revised catalogue of Isoptera (white ants) of the Entomological Reference Collection at the Forest Research Institute, Dehra Dun. *Indian Forest Leaflet (Ent.)*, No. 167 : 1-122. (Errata, pp. 1-9, issued 1963.)
- MATHUR, R.N. AND THAPA, R.S. 1962b (Oct.). A new species of *Stylotermes* (Isoptera : Rhinotermitidae : Stylotermitinae) from India. *J. Timber Dryers & Preserv. Assoc. India*, **8**(4) : 4-8.
- MATHUR, R.N. AND THAPA, R.S. 1963. Survey of the termites of South Bihar. *J. Soc. Indian Foresters*, **3**(3 & 4) : 105-110.
- MAXWELL-LEFROY, H. See LEFROY, H.M.
- MILL, A.E. 1983. Generic keys to the soldier caste of New World Termitidae (Isoptera : Insecta). *Syst. Ent.*, **8**: 179-190.
- MILLER, E.M. 1969. Caste differentiation in the lower termites. In *Biology of Termites* (Ed. by K. Krishna and F.M. Weesner), Vol. 1: 283-310. New York (Academic Press).
- MORIMOTO, K. 1973. Termites from Thailand. *Bull. Govt. Forest Exper. Sta.*, No. 257 : 57-80.
- MULLER, F. 1873. Beitrage zur Kenntnis der Termiten. IV Die Larven von *Calotermes rugosus* Hagen. *Z. Naturwiss.*, **7**: 333-358.
- NOIROT, C. 1969. Formation of castes in the higher termites. In *Biology of Termites* (Ed. by K. Krishna and F.M. Weesner), Vol. 1: 311-350. New York and London (Academic Press).
- NOIROT, C. 1970. The nests of termites. In *Biology of Termites* (Ed. by K. Krishna and F.M. Weesner). Vol. 2: 73-125. New York and London (Academic Press).
- NOIROT, C. AND NOIROT-TIMOTHEE, C. 1969. The digestive system. In *Biology of Termites* (Ed. by K. Krishna and F.M. Weesner), Vol. 1: 49-88. New York and London (Academic Press).
- OSHIMA, M. 1910. On the Formosan termites. (In Japanese.) *Dobust. Zasshi.*, **22**: 343-346; 376-382 and 411-413.

- OSHIMA, M. 1914a (Jan. 16). Two species of termites from Singapore. *Philipp. J. Sci.*, (D) **8**(4) (1913): 283-286.
- OSHIMA, M. 1914b (Dec. 25). Notes on a collection of termites from the East Indian Archipelago (Malaya and the Philippines). *Annot. zool. Jap.*, **8**: 553-585, 2 pls.
- OSHIMA, M. 1914c. On *Coptotermes* of Hong Kong. [In Japanese] *Rept. Res. White Ants.*, Taihoku, **4**: 7-9.
- OSHIMA, M. 1914d. On the white ants of Singapore. [In Japanese.] *Rept. Res. White Ants.*, Taihoku, **4**: 10-16.
- OSHIMA, M. 1914e. Studies on the termites of Indian Archipelago. [In Japanese.] *Rept. Res. White Ants.*, **4**: 17-52.
- OSHIMA, M. 1915a. White ants of the Philippine Islands. [In Japanese.] *Rept. Res. White Ants.*, **5**: 41-54.
- OSHIMA, M. 1915b. *Fifth Report on Termite Investigations.* [In Japanese.]: 88 pp., 5 pls. Taihoku.
- OSHIMA, M. 1916 (Nov.). A collection of termites from the Philippine Islands. *Philipp. J. Sci.*, (D) **11**(6): 351-369, 2 pls.
- OSHIMA, M. 1917a (July). Notes on a collection of termites from Luzon obtained by R.C. McGregor. *Philipp. J. Sci.*, (D) **12**(4): 221-225.
- OSHIMA, M. 1917b. *Sixth Report on Termite Investigations.* [In Japanese.]: 175 pp., 13 pls. Taihoku.
- OSHIMA, M. 1917c. Two species of termites from Foochow, China. *Coll. Essays for Y. Nawa*, 1917 (Ed. by K. Nagano) : 5-7. Gifu.
- OSHIMA, M. 1920 (Nov.). Philippine termites collected by R.C. McGregor, with descriptions of one new genus and nine new species. *Philipp. J. Sci.*, **17**(5): 489-512, 4 pls.
- OSHIMA, M. 1923 (Apr.). Fauna Simulurensis. Termitidae. *Capita Zool.*, **2**(3): 1-22.
- PAL, S.K. AND SHARMA, V.P. 1971. Observations on the vertical distribution and seasonal incidence of *Anacanthotermes macrocephalus* (Desn.) (Insecta : Isoptera). *Indian Forester*, **97**(7): 430-434.

- PARIHAR, D.R. 1978. Field observations on the nature and extent of damage by Indian Desert termites and their control. *Annals arid Zone*, 17(2): 192-199, 2 pls.
- PARIHAR, D.R. 1980. Termite problem in desert plantations. *Annals arid Zone*, 19(3): 329-334.
- PARIHAR, D.R. 1981. Some observations on distribution and pest status of termites attacking forestry plantations in the Rajasthan Desert. *Indian J. Forestry*, 4(1): 22-25.
- PINTO, M.P.D. 1941. Some observations on the biology of the Ceylonese Calotermitidae. *Indian J. Ent.*, 3(1): 73-105.
- PRUTHI, H.S. 1969. *Textbook on Agricultural Entomology*. ix + 1 + 977 pp., 92 pls. New Delhi (Indian Counc. Agric. Res.).
- QUENNEDEY, A. AND DELIGNE, J. 1975. L'arme frontale des soldat de termite. I. Rhinotermitidae. *Insectes Sociaux*, 22(3): 243-267. (Also a new subfam. Prorhinotermitinae.)
- RADCLIFFE, E. 1904 (Sept.). A new termite from India. *Indian Forester*, 30(9): 412-414. *Termopsis Radcliffei* n. sp.
- RAJAGOPAL, D. 1983. Habit and habitat studies of some termites from Karnataka. *J. Soil Biol. Ecol.*, 3(2): 100-121.
- RAO, H., SRINIVASA. 1957. History of our knowledge of the Indian fauna through the ages. *J. Bombay nat. Hist. Soc.*, 54(2): 251-280, 2 pls.
- RATTAN LAL, AND MENON, R.D. 1953. *Catalogue of Indian Insects*. Part 27. *Isoptera*. 4 + 94 pp. Delhi (Govt. of India Press).
- REDDY, M.V. 1980. Structural wood destroying activity of *Coptotermes kishori* Roonwal and Chhotani at Nagaland. *Abstrs. Papers 5th All-India Congr. Zool.* (Bhopal, Nov. 1980) : 95.
- ROONWAL, M.L. 1953 (June). Systematics of oriental termites. No. 1. A new species of termite, *Heterotermes gertrudae*, sp. nov., from North India. (Isoptera, Family Rhinotermitidae). *Indian J. Ent.*, 15(2): 115-118.
- ROONWAL, M.L. 1954a. Biology and ecology of oriental termites (Isoptera). No. 2. On ecological adjustment in nature between two species of termites, namely, *Coptotermes heimi* (Wasmann) and

- Odontotermes redemanni* (Wasmann) in Madhya Pradesh, India. *J. Bombay nat. Hist. Soc.*, **52**: 463-467, 1 pl.
- ROONWAL, M.L. 1954b. A list of insect pests of forest plants in India and the adjacent countries. (Arranged alphabetically according to plant genera and species, for the use of forest officers.) Part 1. General Introduction. *Indian Forest Bull. (N.S.) (Ent.)*, No. 171 (1): 1-4.
- ROONWAL, M.L. 1954c. A brief review of the progress of entomology in India during the period 1938-1950, together with a bibliography. *Mem. ent. Soc. India*, No. 3: 1-119.
- ROONWAL, M.L. 1954d. Biology and ecology of oriental termites. No. 1. *Odontotermes parvidens* Holmg. and Holmg. severely damaging the bark and contributing to the death of standing teak trees in Uttar Pradesh, India. *J. Bombay nat. Hist. Soc.*, **52**: 459-462.
- ROONWAL, M.L. 1955. Termites ruining a township. *Z. angew. Ent.*, **38**(1): 103-104.
- ROONWAL, M.L. 1956a. External genitalia of termites (Isoptera). *J. zool. Soc. India*, **7**(2) (1955): 107-114.
- ROONWAL, M.L. 1956b. Isoptera. In *Taxonomist's Glossary of Genitalia in Insects* (Ed. by S.L. Tuxen), pp. 34-38. Copenhagen (S. Munksgaard).
- ROONWAL, M.L. 1958. Recent work on termite research in India (1947-57). *Trans. Bose Res. Inst.*, **22**: 77-100, 4 pls.
- ROONWAL, M.L. 1959. Biology and ecology of oriental termites (Isoptera). No. 4. The drywood termite *Coptotermes heimi* (Wasm.) in India. *J. Bombay nat. Hist. Soc.*, **56**(3): 511-523, 3 pls.
- ROONWAL, M.L. 1962a. Address by the President. In *Termites in the Humid Tropics (Proc. New Delhi Sympos. 1960)*: 9-11. Paris (Unesco).
- ROONWAL, M.L. 1962b. Recent developments in termite systematics (1949-1960). In *Termites in Humid Tropics (Proc. New Delhi Symp., 1960)*: 31-50. Paris (Unesco).
- ROONWAL, M.L. 1964. Termite measurements and indices. In *Etudes sur les Termites Africains (Un Coloq. int. Unesco, Leopoldville (Univ. Lovanium))*: 69-75. Paris (Masson et Cie).

- ROONWAL, M.L. 1970a. Termites of the Oriental region. In *Biology of Termites* (Ed. by K. Krishna and F.M. Weesner), Vol. 2: 315-391. New York and London (Academic Press).
- ROONWAL, M.L. 1970b. Measurements of termites (Isoptera) for taxonomic purposes. *J. zool. Soc. India*, 21(1) (1969) : 9-66.
- ROONWAL, M.L. 1970c. Isoptera. In *Taxonomist's Glossary of Genitalia in Insects* (2nd Ed.). (Ed. by S.L. Tuxen), pp. 41-46. Copenhagen (S. Munksgaard).
- ROONWAL, M.L. 1972a. Papillae on tibial spines and spurs in the termite *Mastotermes darwiniensis*. *Sci. & Culture*, 38(5): 255.
- ROONWAL, M.L. 1972b. Opening remarks by the Chairman. In *Termite Problems in India* (Ed. by M.L. Roonwal): vii - viii. New Delhi (Counc. sci. & ind. Res.).
- ROONWAL, M.L. (Ed. by). 1972c. *Termite Problems in India*. (A symposium held under the auspices of the Biological Research Committee, Council of Scientific and Industrial Research, New Delhi, March, 1970.): viii + 81 pp. New Delhi (Counc. sci. & ind. Res.).
- ROONWAL, M.L. 1973. On a new phylogenetically significant ratio (Width/Length in termite eggs (Isoptera)). *Abstrs. Sympos. Orient. Ent.*, (Calcutta, Nov., 1973) : 10-11.
- ROONWAL, M.L. 1974. Occurrence of papillae on tibial spines and spurs in the Australian termite, *Mastotermes darwiniensis*, with remarks on some other primitive species. *J. zool. Soc. India*, 24(2) (1972): 155-160.
- ROONWAL, M.L. 1975a. Phylogeny and status of termite families Stylotermitidae and Indotermitidae with three-segmented tarsi, and the evolution of tarsal segmentation in the Isoptera. *Biol. Zbl*, 94(1): 27-43.
- ROONWAL, M.L. 1975b. On a new phylogenetically significant ratio (Width/Length) in termite eggs (Isoptera). *Zool. Anz.*, 195(1-2) : 43-50.
- ROONWAL, M.L. 1975c. Field and other observations on the Harvester Termite, *Anacanthotermes macrocephalus* (Hodotermitidae), from the Indian Desert. *Z. angew. Ent.*, 78(4): 424-440.

- ROONWAL, M.L. 1975d. Sex ratios and sexual dimorphism in termites. *J. sci. & ind. Res.*, **34**: 402-416.
- ROONWAL, M.L. 1975e. Thar Desert termites. In *Environmental Analysis of the Thar Desert* (Ed. by R.K. Gupta and I. Prakash): 393-422. Dehra Dun (English Book Depot).
- ROONWAL, M.L. 1976. Field ecology and eco-biogeography of Rajasthan termites : A study in desert environment. *Zool. Jahrb. (Syst.)*, **103**: 455-504.
- ROONWAL, M.L. 1977a. Micro-sculpturing on termite wings (Isoptera), and its significance. *Proc. zool. Soc. Calcutta*, **28**(1975): 31-39.
- ROONWAL, M.L. 1977b. Rajasthan termites (Insecta Isoptera). In *The Natural Resources of Rajasthan* (Ed. by M.L. Roonwal), Vol. 1: 373-379, 1 pl. Jodhpur (Univ. of Jodhpur).
- ROONWAL, M.L. 1977c. Termite ecology in the Indian Desert ecosystem. A review of recent work. In *Desert Eco-System and Its Improvement* (Ed. H.S. Mann): 323-328. Jodhpur (Central Arid Zone Res. Inst., Monogr. No. 1).
- ROONWAL, M.L. 1978a. Bioecological and economical observations on termites of Peninsular India. *Z. angew. Ent.*, **85**(1) : 15-30.
- ROONWAL, M.L. 1978b. Termites from the Himalaya. (In Symposium on Impact of Man on the Mountain Ecosystem, Agra 1976.) *Mem. School of Ent.* (St. John's College, Agra), No.6 : 101-106.
- ROONWAL, M.L. 1978c. Field data on intraspecific variability in mound construction and nesting habits in termites and its ecological relationships. *Proc. Indian natnl. Sci. Acad.*, (B)**43**(5)(1977) : 159-174 (2 pls.)
- ROONWAL, M.L. 1979a. Termite damage to railway coaches in India. (*Coptotermes heimi*). *Indian J. Forestry*, **2**(4) : 307-310.
- ROONWAL, M.L. 1979b. *Termite Life and Termite Control in Tropical South Asia*. xii + 177 pp., 8 pls. Jodhpur (Scientific Publishers).
- ROONWAL, M.L. 1981a. Evolution and systematic significance of wing micro-sculpturing in termites (Isoptera). XI. Some hitherto unstudied genera and species in five families. *Proc. Indian natn. Sci. Acad.*, (B)**47** : 467-473.

- ROONWAL, M.L. 1981b. Termites of agricultural importance in India and their control. In *Progress in Soil Biology and Ecology in India* (Ed. by G.K. Veeresh) : 253-265. Bangalore (Univ. Agric. Sci.).
- ROONWAL, M.L. 1982a. The identity of two economically important termites, *Heterotermes gertrudae* and *H. indicola* (Rhinotermitidae), from India. *Bull. Ent.*, **23** 1-4.
- ROONWAL, M.L. 1982b. The termite *Heterotermes indicola* as a pest of the vegetable *Karela* or bitter gourd (*Momordia charantia*) in the Indian Desert. *Ann. Arid Zone*, **21**(3) 131-133.
- ROONWAL, M.L. 1982c. Fauna of the Great Indian Desert. Past and present composition, zoogeography, ecology, biology, physiology and conservation. In *Desert Resources and Technology* (Ed. by Alam Singh), Vol 1 : 1-86 (8 pls.). Jodhpur (Scientific Publishers and Geotech-Academia).
- ROONWAL, M.L. 1983a. The ecology of termite swarming in the Indian Desert. In *Insect Interrelations in Forest and Agroecosystems* (Ed. by P.K. Sen-Sarma, S.K. Sangal and S.K. Kulshrestha) : 9-13. Dehradun (Jugal Kishore & Co.).
- ROONWAL, M.L. 1983b. Universal occurrence of external cuticular, microscopic papillae and allied structures as an essential character of termites (Isoptera, Insecta), and redefinition of the order. *Zool. Anz.*, **211**(1-2) : 137-144.
- ROONWAL, M.L. 1983c. Evolution and systematic significance of wing micro-sculpturing in termites. XIII. Order Isoptera. *Proc. Indian natn. Sci. Acad.*, (B) **49**(5) : 359-391(4 pls.).
- ROONWAL, M.L. 1984. The abdomen, genitalia and accessory structures in termites (Isoptera). *Mem. ent. Soc. India*, No. 9 : 1-79.
- ROONWAL, M.L. 1985a. Wing microsculpturing in termites (Isoptera) under the scanning electron microscope. *Zool. Anz.*, **215**(3-4) : 219-230.
- ROONWAL, M.L. 1985b. Scanning electron microscopic studies of wing microsculpturing in termites (Isoptera). I. Genera *Heterotermes* and *Microtermes*. *Proc. Indian natn. Sci. Acad.*, (B)**51**(1) : 6-14(4 pls.).

- ROONWAL, M.L. 1985c. The Har Swarup Memorial Lecture. Recent researches on wing microsculpturing in termites (Isoptera), and its evolutionary and biological significance. *Proc. Indian natnl. Sci. Acad.*, (B)51(2) : 135-168 (12 pls.).
- ROONWAL, M.L. 1985d. Scanning electron microscopic studies of wing microsculpturing in termites (Isoptera). II. Genera *Amitermes* and *Eremotermes* (Termitidae, Amitermitinae). *Proc. Indian natnl. Sci. Acad.*, (B)51(3) : 310-318.
- ROONWAL, M.L. 1986. Second contribution to wing microsculpturing in termites (Isoptera) under the scanning electron microscope. *Zool. Anz.*, 216 : 81-89.
- ROONWAL, M.L. 1988. Field ecology and soldier polymorphism in the Indian Sand Termite, *Psammotermes rajasthanicus* (Rhinotermitidae, Psammotermitinae). *Indian J. Ent.*, 47(4) : 455-460
- ROONWAL, M.L. AND BOSE, G. 1960(July). A new termite, *Psammotermes rajasthanicus* sp. nov. from Rajasthan, India. *Sci. & Culture*, 26(1) : 38-39.
- ROONWAL, M.L. AND BOSE, G. 1962 (Dec. 28). An African genus *Psammotermes* in Indian termite fauna, with fuller description of *P. rajasthanicus* from Rajasthan, India, *Rec. Indian Mus.*, 58(3-4)(1960) : 151-158, 2 pls.
- ROONWAL, M.L. AND BOSE, G. 1964. Termite fauna of Rajasthan, India. *Zoologica*, 40(3) (Heft 113) : VI + 58 pp., 5 pls.
- ROONWAL, M.L. AND BOSE, G. 1965. Zoogeography of Andaman and Nicobar termites. *Bull. syst. Zool.*, 1(1) : 3-4.
- ROONWAL, M.L. AND BOSE, G. 1969. Fauna of Rajasthan, India. Part 4. A check-list of Rajasthan termites (Insecta : Isoptera). *Rec. zool. Surv. India*, 61(3-4) (1963) : 437-450d, 4 pls.
- ROONWAL, M.L. AND BOSE, G. 1970a (Oct.). Taxonomy and zoogeography of the termite fauna of Andaman and Nicobar Islands, Indian Ocean. *Rec. zool. Surv. India*, 62(3-4) (1964) : 109-170d, 4 pls.
- ROONWAL, M.L. AND BOSE, G. 1970b. Scaly serrations on spines and apical spurs of tibia in the Himalayan Termite *Archotermopsis wroughtoni*. *Sci. & Cult.*, 36(12) : 673.

- ROONWAL, M.L. AND BOSE, G. 1978. Vegetational distribution of termites of Rajasthan (India) and their economic importance. *Proc. Indian natnl. Sci. Acad.*, (B)44(5) 320-329 + 1 (addendum).
- ROONWAL, M.L. AND BOSE, G. 1988. The harvester termites (*Anacanthotermes*) of the Indian Region. Identity, distribution and biology (Isoptera, Hodotermitidae). *Occ. Pap. Rec. zool. Surv. India*, No. 111. 1-61.
- ROONWAL, M.L., BOSE, G. AND VERMA, S.C. 1984. The Himalayan Termite, *Archotermopsis wroughtoni* (Synonyms *radcliffei* and *deodarae*). Identity, distribution and biology. *Rec. zool. Surv. India*, 81(3-4) 315-338, 2 pls.
- ROONWAL, M.L. AND CHHOTANI, O.B. 1959. New neotropical element (*Anoplotermes*) in Indian termite fauna. *Nature*, 184 1967-1968.
- ROONWAL, M.L. AND CHHOTANI, O.B. 1960a. The apical tibial spur formula in the termite genus *Coptotermes*. *J. zool. Soc. India*, 11(2) (1959) 125-132.
- ROONWAL, M.L. AND CHHOTANI, O.B. 1960b. *Anoplotermes shillongensis* sp. nov., a new termite from Assam, India. *Sci. & Cult.*, 25(12) : 701.
- ROONWAL, M.L. AND CHHOTANI, O.B. 1960c. Soldier caste found in the termite genus *Speculitermes*. *Sci. & Cult.*, 26(3) : 143-144.
- ROONWAL, M.L. AND CHHOTANI, O.B. 1961. The more important wood-destroying termites of India. *Proc. Sympos. Timber & Allied Products* (New Delhi, May 1959) 89-96. New Delhi (Natn. Bldg. Organis., Govt. of India).
- ROONWAL, M.L. AND CHHOTANI, O.B. 1962a (Aug. 26). Termite fauna of Assam region, eastern India. *Proc. natn. Inst. Sci. India*, (B)28(4) : 281-406, 26 pls.
- ROONWAL, M.L. AND CHHOTANI, O.B. 1962b (Nov.). *Indian Species of Termite Genus Coptotermes*, ix + 115 pp. (18 pls.). Delhi (Indian Counc. Agric. Res., Ent. Monogr. No. 2), [Manager of Publ., Govt. of India.]
- ROONWAL, M.L. AND CHHOTANI, O.B. 1962c (Dec. 28). A new neotropical element (*Anoplotermes*) in the Indian termite fauna, with fuller description of *A. shillongensis* from Assam. *Rec. Indian Mus.*, 58(3&4) (1960) : 159-168, 1 pl.

- ROONWAL, M.L. AND CHHOTANI, O.B. 1963. Discovery of the termite genus *Procryptotermes* (Isoptera, Kalotermitidae) from Indo-Malayan Region, with a new species from India. *Biol. Zbl.*, **82**(3) 265-273.
- ROONWAL, M.L. AND CHHOTANI, O.B. 1965. Zoogeography of termites of Assam Region, India, with remarks on speciation. *J. Bombay nat. Hist. Soc.*, **62**(1) 19-31.
- ROONWAL, M.L. AND CHHOTANI, O.B. 1966. Soldier and other castes in the termite genus *Speculitermes* and the phylogeny of the *Anoplotermes* - *Speculitermes* complex. *Biol. Zbl.*, **85** 183-210.
- ROONWAL, M.L. AND CHHOTANI, O.B. 1967a. Indian wood-destroying termites. *J. Bombay nat. Hist. Soc.*, **63**(2) (1966) 354-364, 2 pls.
- ROONWAL, M.L. AND CHHOTANI, O.B. 1967b. Wing microsculpturing in termite genera *Odonototermes*, *Hypotermes* and *Microtermes* (Termitidae : Macrotermitinae), and its taxonomic value. *Zool. Anz.*, **178** 236-262, 1 figd. table.
- ROONWAL, M.L. AND CHHOTANI, O.B. 1977. Ergebnisse der Bhutan - Expedition 1972 des Naturhistorischen Museums Basel. Isoptera (termites). *Entomologica Basiliensia*, **2** : 39-84.
- ROONWAL, M.L. AND CHHOTANI, O.B. 1986. The identity of South Asian termite *Indotermes rongrensis* (R. & C.) (Synonyms *Speculitermes cyclops rongrensis* and *I. bangladeshiensis*) (Isoptera, Indotermitidae). *Rec. zool. Surv. India*, **83**(3&4) : 155-163.
- ROONWAL, M.L. CHHOTANI, O.B. AND BOSE, G. 1962. Some recent zoogeographical findings in Indian termites. In *Termites in Humid Tropics* (Proc. New Delhi. Sympos., 1960): 51-54, 1 pl. Paris (Unesco).
- ROONWAL, M.L. CHHOTANI, O.B. AND VERMA, S.C. 1981. Evolution and systematic significance of wing microsculpturing in termites (Isoptera). X. Subfamily Nasutitermitinae of family Termitidae. *Proc. Indian natnl. Sci. Acad.*, (B) **47**(3) : 341-369 (3 pls.).
- ROONWAL, M.L. AND KRISHNA, K. 1955. Systematics of oriental termites. II. A new species, *Coptotermes gaurii*, from Ceylon. *Indian J. agric. Sci.*, **25**(2) : 143-152.

- ROONWAL, M.L. AND MAITI, P.K. 1965 (Sept.). First record of termite genus *Postelectrotermes* (Kalotermitidae) from India, with description of a new species. *Indian J. Ent.*, 27(3) : 255-261.
- ROONWAL, M.L. AND MAITI, P.K. 1966. Termites from Indonesia, including West Irian. *Treubia*, 27(1) : 63-140.
- ROONWAL, M.L. AND PANT, G.D. 1953. A Systematic Catalogue of the Main Identified Entomological Collection at the Forest Research Institute, Dehradun. Part 9. Isoptera. *Indian Forest Leaflet (Ent.)*, No. 121(3) 39-60.
- ROONWAL, M.L. AND RATHORE, N.S. 1972. Sex ratios, sexual dimorphism, body-weight and moisture-content in two desert termites, *Anacanthotermes macrocephalus* (Hodotermitidae) and *Microtermes mycophagus* (Termitidae), from India. *Ann. arid Zone*, 11(1-2) : 92-110.
- ROONWAL, M.L. AND RATHORE, N.S. 1975a. Swarming, egg-laying and hatching in the Indian Desert harvester termite, *Anacanthotermes macrocephalus* (Hodotermitidae). *Ann. arid zone*, 14 (4) : 329-338.
- ROONWAL, M.L. AND RATHORE, N.S. 1977. Third study of evolution and systematic significance of wing micro-sculpturing in termites : Micrasters in some Rhinotermitidae and Termitidae. *Zool. Anz.*, 198(5-6) : 298-312.
- ROONWAL, M.L. AND RATHORE, N.S. 1978. Evolution and systematic significance of wing micro-sculpturing in termites (Isoptera) : New types in the Kalotermitidae and the Hodotermitidae. *Zool. Anz.*, 200(3-4) : 219-232.
- ROONWAL, M.L. AND RATHORE, N.S. 1979. Egg-wall sculpturing and micropylar apparatus in some termites and their evolution in the Isoptera. *J. zool. Soc. India*, 27(1-2) (1975) : 1-17.
- ROONWAL, M.L. AND RATHORE, N.S. 1982. Evolution and systematic significance of wing-micro-sculpturing in termites (Isoptera). XII. Sculpturing on wing scales. *Proc. Indian natnl. Sci. Acad.*, (B) 48(3) : 322-343
- ROONWAL, M.L. AND RATHORE, N.S. 1983. Wing microsculpturing in the small house cockroach, *Supella longipalpa* (Dictyoptera, Blattidae). *Proc. Indian Acad. Sci. (Anim. Sci.)*, 92(4) : 333-342.

- ROONWAL, M.L. AND RATHORE, N.S. 1984. Wing microsculpturing in some Embioptera (Insecta), with a new type of structure and ecological and taxonomic considerations. *Indian J. Ent.*, **45**: 323-334.
- ROONWAL, M.L. AND RATHORE, N.S. 1985. Wing microsculpturing in the Brazilian termite family Serritermitidae (*Serritermes serrifer*, Isoptera), and its bearing on phylogeny. *Proc. Indian Acad. Sci. (Anim. Sci.)*, **94**(4) : 399-406.
- ROONWAL, M.L. AND RATHORE, N.S. 1986. Wings and wing microsculpturing in the termite family Indotermitidae (*Indotermes*, Isoptera), and their bearing on phylogeny. *Proc. Indian Acad. Sci. (Anim. Sci.)*, **95**(2) : 191-197.
- ROONWAL, M.L. AND RATHORE, N.S. 1987. Wing microsculpturing in two Arabian species of termite genus *Amitermes* (Termitidae, Amitermitinae). *Proc. Indian Acad. Sci. (Anim. Sci.)*, **96**(6) : 715-719.
- ROONWAL, M.L. AND SEN-SARMA, P.K. 1955. Biology and ecology of oriental termites (Isoptera). No. 3. Some observations on *Neotermes gardneri* (Snyder) (Family Kalotermitidae). *J. Bombay nat. Hist. Soc.*, **53**(2) : 234-239, 2 pls.
- ROONWAL, M.L. AND SEN-SARMA, P.K. 1956 (Apr. 20). Systematics of oriental termites. (Isoptera). No. 3. Zoological Survey of India Collections from India and Burma, with new termites of the genera *Parrhinotermes*, *Macrotermes*, *Hypotermes* and *Hospitalitermes*. *Indian J. agric. Sci.*, **26**(1) : 1-37.
- ROONWAL, M.L. AND SEN-SARMA, P.K. 1960 (Jan.). *Contributions to the Systematics of Oriental Termites*. xiv + 407 pp. (65 pls.). New Delhi (Ent. Monogr. No.1, Indian Counc. Agric. Res.).
- ROONWAL, M.L. AND THAKUR, M.L. 1963 (June). Two new species of termites (Rhinotermitidae), *Prorhinotermes shiva* and *Schedorhinotermes tiwarii*, from the Andaman Islands (Bay of Bengal). *Indian J. agric. Sci.*, **33**(2) : 102-117.
- ROONWAL, M.L. AND VERMA, S.C. 1971. A new termite of genus *Postelectrotermes* (Isoptera : Kalotermitidae) from India, with distribution of and keys to oriental species. *Indian Zoologist*, **2** : 83-91.

- ROONWAL, M.L. AND VERMA, S.C. 1972 (Aug.). A new wood-infesting termite of genus *Neotermes* (Isoptera Kalotermitidae) from India. *Proc. natn. Acad. Sci. India*, (B) 41(3) (1971) : 251-256.
- ROONWAL, M.L. AND VERMA, S.C. 1973. First record of termite genus *Incisitermes* Krishna (Kalotermitidae) from Indian Region, with description of a new species from Rajasthan. *Zool. Anz.*, 191(5-6) : 390-397.
- ROONWAL, M.L. AND VERMA, S.C. 1976. Imago of the wood termite *Heterotermes gertrudae* Roonwal (Rhinotermitidae : Heterotermitinae) from North-West Himalayas. *Rec. zool. Surv. India*, 69 : 241-247.
- ROONWAL, M.L. AND VERMA, S.C. 1977. Re-survey of the termite fauna of Rajasthan, India, and its zoogeography. *Rec. zool. Surv. India*, 72 : 425-480.
- ROONWAL, M.L. AND VERMA, S.C. 1980a. Evolution and systematic significance of wing-micro-sculpturing in termites (Isoptera). VIII. Subfamily Amitermitinae of family Termitidae. *Proc. Indian natn. Sci. Acad.*, (B) 46(3) : 250-263.
- ROONWAL, M.L. AND VERMA, S.C. 1980b. Evolution and systematic significance of wing micro-sculpturing in termites (Isoptera). IX. Subfamily Termitinae of family Termitidae. *Proc. Indian natn. Sci. Acad.*, (B) 46(4) : 455-469.
- ROONWAL, M.L. AND VERMA, S.C. 1983. New data on wing micro-sculpturing in termites (Kalotermitidae, Rhinotermitidae and Termitidae). *Ann. Ent.*, 1(1) : 27-34.
- ROONWAL, M.L. AND VERMA, S.C. 1985. Scanning electron microscopic studies of wing microsculpturing in termites, (Isoptera). III. Genera *Odontotermes* and *Macrotermes* (Termitidae, Macrotermitinae). *Proc. Indian. natn. Sci. Acad.*, (B) 51(4) : 405-412 (4 pls).
- ROONWAL, M.L. AND VERMA, S.C. 1988. Scanning electron microscopic study of cuticular papillae on tibial spines and spurs of some termites (*Mastotermes* and *Archotermopsis*). *Indian J. Ent.*, 47(4) : 452-454, 2 pls.
- ROONWAL, M.L., VERMA, S.C. AND BISEN, S.S. 1986. Scanning electron microscopic studies of wing microsculpturing in termites (Isoptera).

- IV Families Kalotermitidae, and general considerations. *Proc. Indian natn. Sci. Acad.*, (B) 52(2), 241-266 (13 pls).
- ROONWAL, M.L., VERMA, S.C. AND BISEN, S.S. (In Press). Scanning electron microscopic studies of wing microsculpturing in termites (Isoptera). VI. Genera *Psammotermes*, *Coptotermes* and *Dolichorhinotermes* (Rhinotermitidae). *Proc. Indian natn. Sci. Acad.*
- ROONWAL, M.L. VERMA, S.C. AND RATHORE, N.S. 1974. On a new systematic character in termites, the micrasters. *Z. zool. System. u. Evolutionsforsch.*, 12(1) : 55-76.
- ROONWAL, M.L., VERMA, S.C. AND RATHORE, N.S. 1980. Evolution and systematic significance of wing micro-sculpturing in termites (Isoptera). VII. Subfamily Macrotermitinae of family Termitidae. *Proc. Indian natn. Sci. Acad.*, (B) 46(2) : 149-163 (2 pls).
- ROONWAL, M.L., VERMA, S.C. AND THAKUR, M.L. 1979a. Evolution and systematic significance of wing micro-sculpturing in termites (Isoptera). V Families Mastotermitidae, Termopsidae, Hodotermitidae and Stylotermitidae. *Proc. Indian natn. Sci. Acad.*, (B) 45(2) : 115-128 (2 pls.).
- ROONWAL, M.L., VERMA, S.C. AND THAKUR, M.L. 1979b. Evolution and systematic significance of wing micro-sculpturing in termites (Isoptera). VI. Family Rhinotermitidae. *Proc. Indian natn. Sci. Acad.*, (B) 45(4) : 332-353.
- ROSEN, K. VON. 1912 (Feb. 27). Neue Termiten aus der zoologischen Staatssammlung in München sowie einigen anderen Sammlungen. *Zool. Anz.*, 39 : 221-232.
- SALIHAN, Z. 1982. *The Cuticular Structures Lining the Alimentary Canal of Termites and Their Phylogenetic Significance*, Ph.D. thesis, University of Punjab, Lahore, 356 pp.
- SANDS, W.A. 1972. The soldierless termites of Africa (Isoptera : Termitidae). *Bull. Br. Mus. nat. Hist. (Ent.)*, Suppl., No. 18 : 1-244, 9 pls.
- SCHMIDT, H. (Ed. by). 1955. *Die Termiten, Ihre Erkennungsmerkmale und wirtschaftliche Bedeutung*. 309 pp. Leipzig (Akad. Verlagsgesell. Geest & Porting K.-G.).
- SEEVERS, C.H. 1957. A monograph on the termitophilous Staphylinidae (Coleoptera). *Fieldiana (Zool.)*, 40 : 1-334.

- SEN-SARMA, P.K. 1974. Ecology and biogeography of the termites of India. In *Ecology and Biogeography in India* (Ed. by M.S. Mani) : 421-472. The Hague (W. Junk Publ.).
- SEN-SARMA, P.K. 1981. Recent advances in termite research in India, and future strategy. In *Progress in Soil Biology and Ecology in India* (Ed. by G.K. Veeresh) 236-253. Bangalore (Univ. Agric. Sci.).
- SEN-SARMA, P.K. AND CHATTERJEE, P.N. 1965. Colony foundation through substitute reproductives in *Heterotermes indicola* (Wasmann) under laboratory conditions (Insecta : Isoptera). *J. Timber Develop. Assoc.*, 11(3) : 9-11, 1 pl.
- SEN-SARMA, P.K. AND MATHUR, R.N. 1957. Further record of occurrence of *Cryptotermes dudleyi* (Banks) in India (Insecta : Isoptera : Kalotermitidae). *Current Sci.*, 26(12) : 399.
- SEN-SARMA, P.K. AND MISHRA, S.C. 1972. Seasonal fluctuations of colony composition and population in *Neotermes bosei* Snyder (Insecta: Isoptera : Kalotermitidae). *J. Indian Acad. Wood. Sci.*, 3(2) : 43-48.
- SEN-SARMA, P.K. AND MISHRA, S.C. 1978. Population of soldiers in termite colonies (Insecta : Isoptera). *Abstrs. Sympos. Ecol. of anim. Popul.* (Calcutta, Oct. 1978) : 68-69.
- SEN-SARMA, P.K. AND THAKUR, M.L. 1978. Population ecology of Indian termites. *Bull. Ent.*, 19 : 89-99.
- SEN-SARMA, P.K. AND THAKUR, M.L. 1979 (Feb.). Termites of Tripura (Insecta : Isoptera). *Indian Forest Rec. (N.S.) (Ent.)*, 13(1) : i-ii + 1-67 11 pls).
- SEN-SARMA, P.K. AND THAKUR, M.L. 1980. On a collection of termites of Kumaon Hills, Uttar Pradesh, India (Insecta : Isoptera). *Indian Forest Rec. (N.S.) (Ent.)*, 14(1) : 1 + 1-30.
- SEN-SARMA, et al. 1975. *Wood Destroying Termites of India (Final Tech. Rep. PL. 480 Project A7-FS-58)* vii + 187 + 2 pp.
- SILVESTRI, F. 1901. Nota preliminare sui Termitidi Sud-Americani. *Boll. Mus. Zool. Anat. Comp. Torino.*, 16(389) : 1-8.
- SILVESTRI, F. 1909. In Michaelsen, W. and Harteneyer, R., *Die Fauna Südwest Austral.*, 2(17): 279-314.

- SILVESTRI, F. 1914 (July). Zoological results of the Abor Expedition, 1911-12. XXXII. Termitidae. *Rec. Indian Mus.*, 8(5) : 425-435.
- SILVESTRI, F. 1923. (Apr.). The fauna of an island in the Chilka Lake. Part III. No.1. The termites of Barkuda Island. *Rec. Indian Mus.*, 25(2) : 221-232.
- SILVESTRI, F. [In J.B. BATHELLIER]. 1927. [New species of termites from Indo-China.] In *Contributions a l' etude systematique et biologique des termites de l' Indochine*. (Fauna colonie Fr.), Paris, 1 + 121-365 + 3. (New termites, pp. 132, 175, 177, attributed by Bathellier to Silvestri.)
- SILVESTRI, F. 1939. *Compendio di Entomologia Applicata (Agraria-Forestale-Medica-Veterinaria)*. Vol. 1 (2), *Parte speciale*, : 449-974. Portici(Tipographia Bellavista).
- SILVESTRI, F. 1947. Seconda nota su alcuni termitofili del' Indocina con una appendice sul *Macrotermes barneyi* Light. *Bull. Lab. Ent. Agr. Portici*, 7 : 13-40.
- SJÖSTEDT, Y. 1900 (Apr. 11). Monographie der Termiten Afrikas. *K. svenska VetenskAkad. Handl.*, 34(4) : 1-236, 9 pls.
- SJÖSTEDT, Y. 1904 (Sept. 3). Monographie der Termiten Afrikas. *K. svenska VentenskAkad. Handl.*, 38(4) : 1-120, 4 pls.
- SJÖSTEDT, Y. 1925. Nevue Termiten aus Africa und Madagascar. *Konowia*, 4(1&2) : 53-55.
- SJÖSTEDT, Y 1926. Revision der Termiten Afrikas. 3. Monographie. *K. svenska VetenskAkad. Handl.*, (3) 3(2) : 1-419, 16 pls.
- SMEATHMAN, H. 1781. Some account of the termites which are found in Africa and other hot climates. *Philos. Trans. roy. Soc. Lond., London*, 71(1) : pp. 139-192, 4 pls.
- SNYDER, T.E. 1920. Two new termites from Arizona. *Proc. ent. Soc. Washington*, 22(2) : 38.
- SNYDER, T.E. 1923 (Mar. 19). A new *Reticulitermes* from the orient. *J. Wash. Acad. Sci.*, 13(6) : 107-109.
- SNYDER, T.E. 1933 (Apr. 28). New termites from India. *Proc. U.S. natn. Mus.*, 82(Art. 16) : 1-15, 1 pl.

- SNYDER, T.E. 1934 (Sept. 29). New termites from India. *Indian Forest Rec. (Ent.)*, **20**(11) : 1-28.
- SNYDER, T.E. 1935. *Our Enemy, the Termite*. xii + 196 pp., 10 pls. Ithaca, N.Y (Comstock Publ. Co.).
- SNYDER, T.E. 1925. Notes on fossil termites with particular reference to Florissant Colorado. *Proc. Biol. Soc. Washington*, **38** : 149-166.
- SNYDER, T.E. 1948. *Our Enemy, the Termite*, (Rev. ed.), xiii + 257 pp., frontpce. London (Constable & Co.); Ithaca, N.Y (Comstock Publ. Co.).
- SNYDER, T.E. 1949. Catalog of the termites (Isoptera) of the world. *Smiths. misc. Colls.*, **112** : 2 + 490 pp.
- SNYDER, T.E. 1956. Annotated subject-heading bibliography of termites : 1350 B.C. to A.D. 1954. *Smiths. misc. Colls.*, **130** : iv + 305 pp.
- SNYDER, T.E. 1961. Supplement to the annotated subject heading bibliography of termites, 1955 to 1960. *Smiths. misc. Colls.*, **143**(3), 4 + 137 pp.
- SNYDER, T.E. 1968. Second supplement to the annotated subject heading bibliography of termites, 1961-65. *Smiths misc. Colls.*, **152**(3): 4+188.
- SU, N. AND TAMASHIRO, M. 1987. An overview of the formosan subterranean termite (Isoptera : Rhinotermitidae) in the world. In *Biology and Control of the Formosan Subterranean Termite* (Proc. int. Symp. Formosan Subterr. Termite, 67 Mtg. Pacif. Ent. Soc. of America, Honolulu, Hawaii, 1985) : 3-14.
- SUMNER, E.C. 1933. The species of the termite genus *Zootermopsis* Emerson (= *Termopsis* Hagen). *Calif. Univ. Publ., Ent.*, **6**(7): 197-229.
- THAKUR, M.L. 1973. Bioecology and zoogeography of the termite genus *Cryptotermes* (Isoptera : Kalotermitidae) in the Indian region. *Abstrs. Sympos. Orient. Ent.* (Calcutta, Nov. 1973) : 30.
- THAKUR, M.L. 1974. Hitherto unknown imago caste of *Stylotermes bengalensis* Mathur et Chhotani (Isoptera Stylotermitidae). *Indian Forester*, **100**(11) : 692-695.
- THAKUR, M.L. 1975a. Further records of occurrence of termite genus *Procryptotermes* Holmgren (Isoptera : Kalotermitidae) in the Indian

- Region, with a new species from South India. *J. Indian Acad. Wood Sci.*, **6**(1) : 29-36.
- THAKUR, M.L. 1975b. Two new species of termite genus *Stylotermes* Holmgren and Holmgren (Isoptera : Stylotermitidae) from the Indian Region. *J. Indian Acad. Wood Sci.*, **6**(2) : 94-105.
- THAKUR, M.L. 1975c. Zoogeography of termites of north-western Himalayan region. *Indian Forester*, **101**(6) : 341-345, 2 pls.
- THAKUR, M.L. 1977. On the specific identity of termite *Reticulitermes assamensis* Gardner (Isoptera : Rhinotermitidae : Heterotermitinae) from Assam, India, *J. Bombay nat. Hist. Soc.*, **74**(1) : 191-195.
- THAKUR, M.L. 1978a. A new species of termite genus *Neotermes* Holmgren (Isoptera : Kalotermitidae) from Kerala, South India. *J. Indian Acad. Wood Sci.*, **9**(1) : 57-61.
- THAKUR, M.L. 1978b. The problem of termite damage in poplars in the bhabar-tarai region of Uttar Pradesh. *Indian J. Forestry*, **1**(3) : 217-222, 2 pls.
- THAKUR, M.L. 1978c. Imago caste of *Neotermes megaoculatus megaoculatus* Roonwal et Sen-Sarma (Isoptera : Kalotermitidae) from Kumaon Hills, Uttar Pradesh. *J. Bombay nat. Hist. Soc.*, **75**: 143-147.
- THAKUR, M.L. 1980a. Bioecology and zoogeography of termite genus *Cryptotermes* (Isoptera : Kalotermitidae) in the Indian Region. *J. Bombay nat. Hist. Soc.*, **76**(1) (1979) : 106-114.
- THAKUR, M.L. 1980b. Ecobiogeography of termites of the Indian arid ecosystem. *Sociobiology*, **5** : 115-131.
- THAKUR, M.L. 1980c. A new species of genus *Neotermes* Holmgren (Isoptera : Kalotermitidae) from the Indian Region. *Bull. Ent.*, **14** (1973) : 91-96.
- THAKUR, M.L. 1984a. Further records of the occurrence and incidence of damage by termites of the genus *Cryptotermes* Banks in India (Isoptera: Kalotermitidae). *J. Bombay nat. Hist. Soc.*, **81**(2), pp. 497-500.
- THAKUR, M.L. 1984b. *Glyptotermes tripurensis* sp. nov. Isoptera : Kalotermitidae) from Tripura, India. *Bull. Ent.*, **25**(2): 151-155.

- THAKUR, M.L. AND SEN-SARMA, P.K. 1979. Revision of termite genus *Heterotermes* Froggatt (Isoptera Rhinotermitidae Heterotermitinae) from the Indian Region. *Indian Forest Rec. (N.S.) (Ent.)*, 13(2) : 1 + 1 + 1-27.
- THAKUR, M.L. AND SEN-SARMA, P.K. 1980. A flourishing colony of *Coptotermes heimi* (Insecta: Isoptera) in a naval boat. *J. Bombay nat. Hist. Soc.*, 76(1979) 188-189.
- THAKUR, R.K. 1984. Additions to the termite fauna of the Thar Desert. *J. Bombay nat. Hist. Soc.*, 81(2) 496-497.
- THAKUR, R.K. AND RATHORE, N.S. 1982. On the occurrence of *Cryptotermes bengalensis* Snyder (Isoptera Kalotermitidae) in Gujarat, India. *J. Bombay nat. Hist. Soc.*, 79(3) : 699-700.
- THAPA, R.S. 1982. Termites of Sabah. *Sabah For Rec.*, No. 12: iv + 374.
- TRUCKENBRODT, W. 1971. Untersuchungen am Ei-Chorion der Termiten *Kalotermes flavicollis* Fabr. unter normalen Bedingungen und nach Behandlung des Weibchens mit Cobcemicid (Insecta, Isoptera). *Z. Morph. Tiere.*, 69 : 48-81.
- TSAI P.H. AND CHEN, N.S. 1963 (May). Termites from South China. [In Chinese, with English summary.] *Acta ent. Sinica*, 12 : 167-198.
- TSAI, P.H. AND CHEN, N.S. 1964. Problems on the classification and fauna of termites in China. *Acta ent. Sinica*, 13(1) : 25-37.
- TSAI, P.H. AND HUANG, F.S. 1980. *The Chinese Termites*. [In Chinese.] 56 pp. Peking (Science Press, Academia Sinica).
- TSAI, P.H. AND HUANG, F.S. 1982. *Parrhinotermes khasii ruihensis* ssp. nov. from China, with notes on the distribution of the genus *Parrhinotermes* Holmgren (Isoptera : Termitidae). [In Chinese with English summary.] *Acta ent. Sinica*. 25 : 306-310.
- TSAI, P.H. AND HUANG, F.S. 1983. A taxonomy of the subfamily Heterotermitinae. (In Chinese). *Acta. Ent. Sinica*, 26 : 43-436.
- TSAI, P.H., HUANG, F.S. AND LI, K.S. 1977. Notes on the genus *Reticulitermes* (Isoptera) from China, with descriptions of new subgenera and new species. *Acta. ent. Sinica*, 20(4) : 465-475.

- TSAI, P.H., HUANG, F.S. AND ZHU, S.M. 1984. Two new species of genera *Indotermes* and *Sinotermes* from Yunnan, China (Isoptera Termitidae). [In Chinese with English summary]. *Zool. Res.*, **5** : 289-294.
- TU, T 1975. The termites of Formosa. *Formosan Sci.*, **9** : 80-87.
- TUXEN, S.L. (Ed. by). 1956. *Taxonomist's Glossary of Genitalia in Insects* (2nd Ed.). 359 pp. Copenhagen (E. Munksgaard).
- VAN BOVEN, J.K.A. 1969. The termite types of the Wasmann Collection in the Natuurhistorisch Museum of Maastricht. *Publ. naturhist. Mus. Genootsch Limburg*, **19**(1-2) 37-61.
- VARMA, R.V 1976. Nest and nest building behaviour of the termite, *Postelectrotermes nayari* (Isoptera : Kalotermitidae). *Bull. ethol. Soc. India*. **1**(3) : 64-67.
- VARMA, R.V 1977a. Influence of juvenile hormone analogue, fomesyl methyl ether, on caste differentiation in termite *Postelectrotermes nayari* Roonwal & Verma, 1971. *Indian J. exp. Biol.*, **15**(7) 564-565.
- VARMA, R.V 1977b. Hitherto unknown imago caste of *Postelectrotermes nayari* Roonwal and Verma, 1971 (Isoptera : Kalotermitidae). *Indian Forester*, **103** : 220-224.
- VERMA, S.C. 1980. Termites (Insecta : Isoptera). In *Fauna of Corbett National Park* (by B.S. Lamba and R.K. Bhatnagar). *Cheetal*, **21**(2-3): 45-46.
- VERMA, S.C. 1984 (Dec.) On a collection of termites (Insecta : Isoptera) from Kerala (India) with a new species of and keys to the Indian species of *Angulitermes* Sjöstedt. *Rec. zool. Surv. India*, **81**(3-4) : 237-254.
- VERMA, S.C. 1985. On a collection of termites (Insecta : Isoptera) from Kerala (India) with a new species of *Pseudocapritermes* Kemner (Part II). *Indian J. Forestry*, **8**(3) : 176-183. (Errata in *Indian J. Forestry*, **8**(4) : 341. 1985).
- VERMA, S.C. AND THAKUR, R.K. 1976. On the occurrence of *Heterotermes gertrudae* Roonwal (Isoptera : Rhinotermitidae : Heterotermitinae) in Dehra Dun Valley, Uttar Pradesh, India. *Newslet. zool. Surv. India*, **2**(4) : 140.

- VERMA, S.C. AND THAKUR, R.K. 1977a. New records of termites (Insecta : Isoptera) from Pune, Maharashtra, India. *Newslet. zool. Surv. India*, 3(5) 259-264.
- VERMA, S.C. AND THAKUR, R.K. 1977b. New records of termites (Insecta : Isoptera) from Bihar and Orissa, India. *Newslet. zool. Surv. India*, 3(5): 361-365.
- VERMA, S.C. AND THAKUR, R.K. 1982. Termites from Madhya Pradesh, India, with new distributional records. *Rec. zool. Surv. India*, 79(3-4) : 311-318.
- VISHNOI, H.S. 1957. The swarming termites of Delhi. *J. Bombay nat. Hist. Soc.*, 54 : 792-793.
- VISHNOI, H.S. 1962. A review of termite fauna from Delhi and its environs. In *Termites in the Humid Tropics* (Proc. New Delhi Sympos., 1960) : 107-109. Paris (Unesco).
- WALKER, F. 1853. *List of Specimens of Neuropterous Insects in the Collection of the British Museum*. Pt. 3. (Termitidae-Ephermeridae). 4+ 477-585 pp. London (Brit. Mus. Nat. Hist.).
- WASMANN, E. 1893 (Sept. 10). Einige neue Termiten aus Ceylon und Madagaskar, mit Bemerkungen über deren Gaste. *Wien. ent. Ztg.*, 12(7) : 239-247.
- WASMANN, E. 1894. *Kritisches Verzeichnis der myrmekophilen und termitophilen Arthropoden. Mit Angabe der Lebensweise und mit Beschreibung neuer Arten*. xvi + 231 pp. Berlin.
- WASMANN, E. 1896a. Die Myromekophilen und Termitophilen. *C.R. 3rd. Congr. int. Zool.* (Leyden, 1895) : 410-440.
- WASMANN, E. 1896b. Neue Termitophilen und Termiten aus Indien. I-III. (Viaggio di Leonardo Fea in Birmania e regione vicine. LXXII.) *Annali Mus. civ. Stor. nat. Genova*, 36(Ser. 2, Vol. 16) : 613-630, 2 pls.
- WASMANN, E. 1896c. Neue Termitophilen und Termiten aus Indien. IV (Nachtrag). (Viaggio di Leonardo Fea in Birmania e regione vicine. LXXII.) *Annali Mus. civ. Stor. nat. Genova*, 37(Ser. 2, Vol. 17): 149-152.

- WASMANN, E. 1897. Viaggio di Leonardo Fea in Birmania e regione vicine. LXXVII. Einige neu termitophile Myrmedonien aus Birma. *Annali Mus. civ. Stor. nat. Genova*, **38** (Ser. 2, Vol. 18) 28-31.
- WASMANN, E. 1899a. Neue Termitophilen und Myremecophilen aus Indien. *Deutsch. ent. Z.*, 1899 (1): 145-169, 2 pls.
- WASMANN, E. 1899b. G.D. Haviland's Beobachtungen über die Termitophile von *Rhopalomalus angusticollis* Boh. *Verh. zool.-bot. Ges. Wien.*, **49** 245-249.
- WASMANN, E. 1899c. Neue Termitophilen mit einer übersicht über die Termitengäste. *Verh. zool.-bot. Ges. Wien.*, **49** 647-658.
- WASMANN, E. 1902a (Oct. 1). Termiten, Termitophilen und Myrmekophilen, gesammelt auf Ceylon von Dr W Horn, 1899, mit andern ostindischen Material bearbeitet. 129. Beiträge zur Kenntnis der Myrmekophilen und der Termitophilen. *Zool. Jb. (Syst.)*, **17**(1) 99-164, 2 pls.
- WASMANN, E. 1902b (July). Verzeichnis der von Dr. W. Horn auf Ceylon 1899 gesammelten Termiten, Termitophilen und Myrmekophilen. *Deutsch. ent. Z.*, **46**(1) 79-80.
- WASMANN, E. 1905. Die phylogenetische Umbildung ostindischer Ameisengäste und Termitengäste. *C.R. 6th Congr. int. Zool.* (Berne, 1904), **6** 436-449, 1 pl.
- WASMANN, E. 1909. Die phylogenetische Umbildung ostindischer Ameisengäste und Termitengäste. *Mitt. schweiz. ent. Ges.*, **11** : 66-70, 1 pl.
- WASMANN, E. 1911a. Termitophile Coleopteren aus Ceylon. In *Termitenleben auf Ceylon, u.s.w.* by K. Escherisch. Systematischer Anhang: Termiten und Termitophilen von Ceylon, pp. 229-232. Jena (G. Fischer).
- WASMANN, E. 1913. Revision der Termitoxeniinae von Ostindien und Ceylon. *Annale Soc. ent. Belg.*, **57** : 16-22.
- WASMANN, E. 1916. Wissenschaftliche Ergebnisse einer Forschungsreise nach Ostindien. V Termitophile und myrmekophile Coleopteren, gesammelt von Prof. Dr. V Buttell-Reepen 1911-1912. *Zool. Jb. (Syst.)*, **39**(2) : 169-210, 2 pls.

- WASMANN, E. 1917. Myrmekophile und termitophile Coleopteren aus Ostindien, gesammelt von P.J. Assmuth, S.J. und J.B. Corporael. I. Paussidae und Clavigerinae. I. Teil. *Tijds. Ent.*, **60**(1917-1918) : 382-408, 3 pls.
- WASMANN, E. 1918. Myrmekophile und termitophile Coleopteren aus Ostindien, hauptsächlich gesammelt von P.J. Assmuth S.J. II. Scarabaeidae. (223. Beitrag zur Kenntnis der Myrmecophilen und Termitophilen). *Wien. ent. Ztg.*, **37** 1-23, 2 pls.
- WASMANN, E. 1925. Kritische Bemerkungen zur Kenntnis der Myrmecophilen und Termitophilen (225. Beitrag.) *Biol. Cbl.*, **45** 136-143.
- WASMANN, E. 1934. *Die Ameisen, die Termiten und ihre Gäste. Vergleichende Bilder aus dem Seelenleben von Mensch und Tier.* xviii + 148 pp., 9 pls. Regensburg (G.I. Manz).
- WEESNER, FRANCES M. 1955. The reproductive system of young primary reproductives of *Tenuirostritermes tenuirostis* (Desneux). *Insectes Sociaux*, **2**: 323-345.
- WEESNER, FRANCES M. 1960. Evolution and biology of termites. *Annual Rev. Ent.*, **5** : 153-170.
- WEESNER, FRANCES M. 1969a. External anatomy. In *Biology of Termites* (Ed. by K. Krishna and F.M. Weesner), Vol. 1: 19-47. New York & London (Academic Press).
- WEESNER, FRANCES M. 1969b. The reproductive system. In *Biology of Termites* (Ed. by K. Krishna and F.M. Weesner), Vol. 1 125-160. New York & London (Academic Press).
- WEESNER, FRANCES M. 1970. Termites of the Nearctic Region. In *Biology of Termites* (Ed. by K. Krishna and F.M. Weesner), Vol. 2 : 477-525. New York & London (Academic Press).
- WEIDNER, H. 1955. Körperbau, Systematik und Verbreitung der Termiten. In *Die Termiten.* (Ed. by H. Schmidt) : 5-81. Leipzig (Akad. Verlagsges. Geest & Portig).
- WEIDNER, H. 1958. Termites (Isoptera) aus dem Irak. *Ent. Mitt. zool. Mus. Hamburg*, No. 17 : 9-16.

- WEIDNER, H. 1960. Die Termiten von Afghanistan, Iran und Irak (Isoptera). (Contribution a l'étude de la faune d' Afghanistan. 29). *Abh. u. Verh. Naturwiss. Vereins Hamburg*, (N.F.) 4(1959) : 43-69.
- WEIDNER, H. 1966a. Betrachtungen zur Evolution der Termiten. *Deutsch. ent. Z.*, (N.F.) 13 323-350.
- WEIDNER, H. 1966b. Die entomologischen sammlung des Zoologischen Statesinstitut und Zoologischen Museum Hamburg. VI. Teil. Insecta. III. *Mitt. Hamburg. zool. Mus. Inst.*, 63 209-264.
- WEIDNER, H. 1970a. Isoptera (Termiten). In *Handb. d. Zool.*, Vol. 4 (Arthropoda), Sec. 2. (Insecta), Pt. 2 (Special), Lief. 13, No. 14 : 1-147. Berlin (W. de Gruyter & Co.).
- WEIDNER, H. 1970b. Termiten aus Nepal. In *Khumbu Himal*, Vol. 3: 457-461. Innsburck (Universitats Verlag, Wagner).
- WEIDNER, H. 1976. Fortschritte in der angewandten Termitenkunde. *Z. Pflanzenkrank.*, 83(11) : 679-698.
- WEIDNER, H. 1981. Fortschritte in der angewandten Termitenkunde, 1976-1980. *Z. Pflanzenkrank. u. Pflanzensch.*, 88(7) : 442-460.
- WEIDNER, H. 1984. Über *Anacanthotermes ochraceus* (Burmeister) (Isoptera, Hodotermitidae) als Schädling an Holzhausern in Arabien nebst einer Liste der bisher aus Arabien bekannten Termitenarten sowie einer Betrachtung der Verbreitung der Palaarktischen *Anacanthotermes* Arten. *Anz. Schadlingskd.*, 57 1-7.
- WESTWOOD, J.O. 1838. *Natural History of the Insects of India*. vi + 102, pp., with pls. London.
- WESTWOOD, J.O. 1840. *Introduction to the Modern Classification of Insects* Vol. 2 London.
- WILLIAMS, R.M.C. 1968. Redescriptions of two termites from Burmese amber. *J. nat. Hist.*, 2 : 547-551.
- WU C.F. 1935. *Catalogus insectorum Sinensim. (Order V. Isoptera.)*, 1 : i -iv + 217-222. Peking.
- XIA, K., GAO, D. AND DENG, Y 1983 (Sept.). Notes on a new species of the genus *Cryptotermes* from Guizhou, China. *Entomotaxonomia*, 5(3) : 247-249.

- XIA, K. AND HE, X. 1980. A study of the Chinese *Schedorhinotermes*, with descriptions of new species (Isoptera, Rhinotermitidae). [In Chinese with English summary.] *Contrib. Shanghai Inst. Ent.*, 1980 : 173-181.
- YU, S. AND PING, C. 1964a. Studies on the faunal regions of Isoptera in China. [In Chinese with English summary.] *Acta ent. Sinica*, 13(1) : 10-24.
- YU, S. AND PING, C. 1964b (May). Systematics of Isoptera from China. I. Descriptions of a new genus, *Operculitermes* (Rhinotermitidae, Heterotermitinae), with reference to its two new species and three new subspecies. [In Chinese, with English summary.] *Acta ent. Sinica*, 13(3) : 344-361.
- YU, S. AND PING, C. 1980. Two new records of *Cryptotermes* from Hainan Island (Isoptera, Kalotermitidae). [In Chinese.] *Acta zootaxonom. Sinica*, 5 : 216-217.
- ZHUZHNIKOV, D.P. 1979. *Termites of the U.S.S.R.* [In Russian.] 244 pp. Moscow.

## INDEX TO TERMITE TAXA

[The synonyms are given in italics and fossils are marked (†). The supra generic categories are given in capital letters. A few other taxa mentioned which do not belong to the order Isoptera are marked with asterisks (\*)].

### A

#### Acanthotermes

*acanthothorax*, 21, 56, 68, 69, 87

#### Acorhinotermes, 519, 520

#### Allognathotermes, 112

*hypogeus*, 75

#### Allotermes, 170

#### Amitermes, 91, 119

*arizonensis*, 56, 60

*belli*, 18

*forelli*, 60

*medius*, 60

*snyderi*, 67

#### AMITERMITINAE, 16, 25, 37, 38, 75, 76, 109, 110, 114, 601

#### Anacanthotermes, 14, 91, 103, 116, 137, 138, 140-144

*ahngerianus*, 141, 142

*baeckmannianus*, 142

*baluchistanicus*, 142, 143, 144-147

*koenigi*, 159, 161

*macrocephalus*, 4, 14, 18, 19, 22, 26, 29,

30, 40, 65, 78, 79, 88, 136, 142, 143,

144, 145, 147-155

*murgabicus*, 142

*ochraceus*, 141, 142

*peshawarensis*, 147, 151

*rugifrons*, 159, 161

*saudiensis*, 142

*septentrionalis*, 141, 142

*turkestanicus*, 141, 142

*ubachi*, 142

*vagans*, 141, 142, 143, 144, 155-158

*viarum*, 142, 143, 144, 145, 159-166

#### Angulitermes, 34, 119

#### Anoplotermes, 76, 83, 101, 112, 119, 120

*pacificus*, 33

*shillongensis*, 101, 112

#### Apicotermes, 75, 112, 119

#### APICOTERMITINAE, 75, 76, 112, 113, 118

#### APTERA\*, 105

#### ARACHNIDA\*, 94

#### Archotermopsis, 22, 28, 41, 42, 91, 115, 124, 125-126

*deodarae*, 126, 127, 134

*radcliffei*, 126

*tornquisti*†, 126

*wroughtoni*, 14, 20, 21, 23, 26, 29, 42, 71, 93, 115, 125, 126-134

#### Arrhinotermes, 6, 117, 418, 419, 420, 521, 522

*heimi* (Coptotermes), 449

*flavus* (Prorrhinotermes), 524

*oceanicus* (Prorrhinotermes), 419

#### ARRHINOTERMITINAE, 110, 117, 518

### B

#### Bicornitermes, 170

*Bifiditermes*, 91, 93, 116, 169, 170, 172, 336-339

*beesoni*, 2, 54, 88, 337, 338, 339-343

*indicus*, 70

*pintoi*, 63, 338, 339, 344-348

*Bulbitermes*, 119

#### BLATTIDAE\*, 39

#### BLATTOIDEA\*, 38, 39

## C

Calcaritermes, 170, 171, 172, 326-328

krishnai, 327, 328-332

imminens, 326

vetus †, 326

Calotermes, 106, 168, 191, 280

artocarp (Neotermes), 206

artocarporum (Neotermes), 206

domesticus (Cryptotermes), 378

greeni (Neotermes), 236

madagascariensis (Bifiditermes), 337

militaris (Postelectrotermes), 179

*militaris unidentatus* (Postelectrotermes),  
179, 180

praecox (Postelectrotermes), 173

rugosus (Rugitermes), 596

CALOTERMITIDAE, 109, 110, 116, 135,  
166, 168

CALOTERMITINAE, 107, 110, 134, 135,  
166, 167, 406

Capritermes, 17, 51, 119

Ceratokalotermes, 170

Coarctotermes

doriae, 87

COLEOPTERA\*, 47, 94

COLLEMBOLA\*, 94

Comatermes, 170

Coptotermes, 6, 27, 28, 47, 68, 91, 93, 117,  
402, 404, 417, 418-422

beckeri, 420, 421, 422-425

ceylonicus, 93, 420, 421, 422, 425-431,  
442

emersoni, 420, 421, 431-434

exiguus, 441, 442

flavus (Prorhinotermes), 524

*formosae*, 434, 435

formosanus, 15, 30, 57, 60, 93, 420, 421,  
422, 434-441

gaurii, 93, 420, 421, 441-445

gestroi, 420, 422, 436, 445-449

heimi, 6, 18, 93, 420, 421, 422, 449-457

*hongkonensis*, 434, 435

*intrudens*, 434, 435

kishori, 420, 421, 457-461

michaelseni, 417

*parvulus*, 93, 449, 451

*raffrayi*, 434, 435

*remotus*, 434, 436

sp., 61

testaceus, 105

travians, 420, 421, 422, 426, 449, 451,  
461-467

COPTOTERMITINAE, 38, 91, 107, 109,  
110, 114, 117, 120, 121, 402, 404, 405,  
416-418

Cornitermes, 119

sp., 61

CORRODENTIA, 106

Coxotermes, 112

Cretatermes, 137

CRETATERMITINAE, 115, 137

CRUSTACEA\*, 94

CRYPTOCLIDOPTERA, 400

Cryptotermes, 57, 58, 68, 93, 116, 170, 171,  
172, 275, 328, 350, 367-373

*angulatus*, 374

bengalensis, 93, 370, 371, 372, 373-377

*brachygnathus*, 374

brevis, 370, 371, 372

*buxtoni*, 378, 379

*campbelli*, 378, 379

cavifrons, 368

*ceylonicus*, 374

cynocephalus, 370, 373

declivis, 370, 371, 372

*dentatus*, 378, 379

domesticus, 370, 371, 378-384

dudleyi, 67, 93, 368, 370, 371, 372,  
384-390

*formosae*, 378

*gulosus*, 378, 379

haviglandi, 67, 373

*hermsi*, 378, 379

*hongkongensis* (Coptotermes), 434, 435

karachiensis, 370, 371, 372, 390-392

*kotoensis*, 378

*lignarius*, 378, 379

*melloi*, 384, 386

*ogasawarensis*, 378, 379

perforans, 67, 370, 371, 373, 393-397

- primus*, 384, 386  
*repentinus*, 378, 379  
 roonwali, 370, 373, 397-399  
*sakauensis*, 370, 372  
*secundus*, 384, 385  
 sp., 56  
*sumatrensis*, 370, 371, 372  
*tectus*, 378, 379  
*thailandis*, 370, 371, 372  
*thompsonae*, 384, 385  
 Cubitermes, 119
- D**
- Dicuspiditermes, 119  
   *incola*, 94  
 DIPLOPODA\*, 94  
 DIPTERA\*, 47, 94  
   Diversitermes  
     *melanocephalus*, 58  
 Dolichorhinotermes, 402, 519, 520
- E**
- Eburnitermes, 75  
 Electrotermes, 170  
**ELECTROTERMITINAE**, 109, 110, 168  
**EMBIOPTERA\***, 39  
 Epicalotermes, 170, 171, 172, 348-350  
   *aethiopicus*, 348  
   *pakistanicus*, 350, 351-353  
 Eremotermes, 37, 57, 58, 119  
   *fletcheri*, 33  
   *neoparadoxalis*, 18  
   *paradoxalis*, 18, 55  
 Eucryptotermes, 170  
 Euhamitermes, 119  
 Eurytermes, 119  
   *isodentatus* (Indotermes), 602  
*Eutermes*, 6, 106, 472
- F**
- Foraminitermes, 109, 110  
 Furculitermes  
   *brevimaculatus*, 62
- G**
- Globitermes, 119  
 Glossotermes, 406, 407, 408  
 Glyptotermes, 91, 93, 116, 170, 171, 172, 280-285, 326, 328, 332  
   *almorensis*, 282, 284, 285, 286-291  
   *arshadi*, 282, 285, 291-293  
   *caudomunitus*, 322  
   *ceylonicus*, 282, 284, 285, 293-296  
   *chinpingensis*, 315  
   *coorgensis*, 282, 284, 285, 296-302  
   *dilatatus*, 20, 21, 282, 284, 285, 302-306, 596  
   *krishnai* (Calcaritermes), 328  
   *minutus*, 283, 284, 285, 306-310  
   *nicobarensis*, 283, 284, 285, 310-313  
   *nigrifrons*, 296, 297  
   *sensarmai*, 283, 285, 313-315  
   *teknafensis*, 283, 284, 285, 315-318  
   *tikaderi*, 283, 284, 318-320  
   *tripurensis*, 283, 285, 320-322  
   *tuberculatus*, 281  
   *ukhiaensis*, 283, 284, 322-326  
*Glyptotermitinae*, 467, 468  
 Grallatotermes, 119
- H**
- Heimitermes, 112  
**HEMIPTERA\***, 94  
 Hemirobius\*, 105  
   *marginalis* (Rhinotermes), 105  
   *testaceus* (Coptotermes), 105  
 Heterotermes, 91, 93, 117, 401, 404, 468, 469, 470, 471-476  
   *balwanti*, 474, 475, 476-479  
   *ceylonicus*, 93, 474, 475, 476, 479-483  
   *gertrudae*, 33, 37, 93, 402, 469, 475, 483-487  
   *indicola*, 18, 37, 93, 402, 469, 473, 475, 483, 487-491  
   *malabaricus*, 93, 475, 476, 491-494  
   *platycephalus*, 472, 474  
   *tenuis*, 44

HETEROTERMITINAE, 38, 109, 110, 114, 120, 121, 402, 404, 405, 406, 467-470

Hodotermes, 6, 14, 41, 106, 116, 134, 135, 137, 139, 140  
mossambicus, 41

HODOTERMITIDAE, 10, 12, 13, 14, 17, 25, 29, 38, 76, 77, 91, 109, 110, 113, 115-116, 119, 121, 122, 123, 134-138

HODOTERMITINAE, 38, 107, 109, 110, 114, 115, 119, 120, 121, 134, 136, 138-140, 147, 148-151

HODOTERMITINI, 134, 135, 138

Hodotermopsis, 115, 124, 125

Hoplognathotermes, 112

Hospitalitermes, 119

HYMENOPTERA\*, 4, 5, 88, 94

Hypotermes, 37  
obscuriceps, 94

## I

Incisitermes, 116, 170, 171, 172, 332-333  
didwanaensis, 333, 334-336  
krishnai, 333  
minor, 333

Indotermes, 23, 111, 118, 599, 600, 602-604

arshadi, 602, 603, 604-606

bangladeshiensis, 602, 609, 610

hainanensis, 602

isodontatus, 602

maymensis, 23, 56, 63, 111, 602, 603, 604, 606-609

pakistanicus, 602, 609, 616

rongrensis, 62, 602, 609-616

thailandis, 15, 16, 602, 603, 609

yunnanensis, 603, 604

INDOTERMITIDAE, 15, 16, 23, 25, 38, 91, 108, 114, 118, 120, 121, 122, 564, 598-601

INSECTA, 90

ISOPTERA, 1, 5, 10, 25, 37, 38, 39, 47, 80, 109, 110

## J

Jugositermes, 112

## K

Kalotermes, 93, 116, 138, 167, 168, 170, 171, 172, 175, 274-276

atratus, 275

beesoni (Bifiditermes), 339

bengalensis (Cryptotermes), 373

flavicollis, 79

jepsoni, 276-280

pintoi (Bifiditermes), 344

schwarzi (Incisitermes), 332

KALOTERMITIDAE, 2, 14, 16, 17, 24, 25, 31, 38, 76, 77, 91, 109, 114, 116, 117, 120, 121, 122, 166-172, 194, 350, 567

KALOTERMITINAE, 109, 168

## L

LEPIDOPTERA\*, 47, 94

Leucotermes, 6, 471, 472, 494, 495

ceylonicus (Heterotermes), 479

indicola (Heterotermes), 487

Leucotermatinae, 107, 109, 406, 467, 468

Lobitermes, 280, 281

lobicephalus (Glyptotermes), 281

## M

Macrorhinotermes, 403, 520

Macrotermes, 68, 119

natalensis, 87

MACROTERTITINAE, 25, 37, 38, 75, 76, 105, 109, 110, 114, 118, 119, 120, 121, 601

Marginitermes, 170

hubbardi, 17

Mastotermes, 22, 41, 42

darwiniensis, 14, 23, 24, 26, 27, 28, 29, 40, 43, 44, 115

MASTOTERTITIDAE, 1, 12, 14, 23, 24, 25, 27, 28, 38, 76, 77, 107, 109, 110, 113, 114-115, 119, 121, 122, 135

Megagnathotermes, 119

MESOTERTITIDAE, 107, 110, 400

METATERTITIDAE, 107, 110

Microcerotermes, 37, 91, 110

amboinensis, 88

beesoni, 88

- fletcheri, 88  
 heimi, 88  
 laxmi, 18  
 raja, 18, 35, 81  
**MICROCEROTERMITINAE**, 110  
 Microhodotermes, 41, 116, 140  
 Microtermes, 34, 37, 91, 119  
   *anandi*, 18  
   mycophagus, 18  
   obesi, 18, 85, 86, 88  
   sp., 6  
 Mirocapritermes, 110  
**MIROCAPRITERMITINAE**, 110
- N**
- Nasutitermes, 91, 119  
   matangensis, 20, 21  
   taylori, 58  
**NASUTITERMITINAE**, 11, 17, 25, 38,  
 59, 72, 83, 86, 109, 110, 114, 118, 120,  
 121, 601  
 Neotermes, 91, 93, 116, 169, 170, 171, 172,  
 175, 191-195  
   *adampurensis*, 194, 196, 198, 199-202  
   *andamanensis*, 194, 196, 198, 202-206  
   *artocarpi*, 60, 194, 196, 198, 206-210  
   *assmuthi*, 195, 196, 198, 210-214  
   *bosei*, 195, 196, 198, 214-220, 221  
   *buxensis*, 30, 31, 195, 196, 197, 220-224  
   *connexus*, 88  
   *dhirendrai*, 195, 199, 225-227  
   *eleanorae*, 195, 196, 199, 227-231  
   *fletcheri*, 195, 197, 231-236  
   *gardneri*, 195, 214, 215  
   *greeni*, 195, 197, 236-241  
   *kalimpongensis*, 195, 197, 242-244  
   *kemneri*, 195, 197, 244-246  
   *keralai*, 195, 198, 246-248  
   *krishnai*, 195, 198, 248-250  
   *mangiferae*, 195, 198, 251-252  
   *megaoculatus*, 253  
   *megaoculatus lakhimpuri*, 195, 197,  
     256-257  
   *megaoculatus megaoculatus*, 195, 196,  
     197, 253-256  
   *microculatus*, 195, 197, 258-259  
   *militaris* (Postelectrotermes), 179  
   *nilamburensis*, 195, 196, 199, 260-263  
   *paratensis*, 195, 196, 199, 263-266  
   *pishinensis* (Postelectrotermes), 190  
   *prosonneratae*, 195, 196, 199, 266-269  
   *shimogensis*, 195, 198, 269-271  
   *tectonae*, 88  
   *venkateshwara*, 195, 198, 271-274  
   *zuluensis*, 41
- NEUROPTERA\***, 105
- O**
- Odontotermes, 31, 37, 41, 47, 68, 91, 92,  
 119  
   *anamallensis*, 92  
   *assmuthi*, 49, 50, 81, 88, 92  
   *brunneus*, 80, 81, 92  
   *ceylonicus*, 93, 94  
   *feae*, 81, 92, 93, 94  
   *giriensis*, 62  
   *guptai*, 18  
   *gurdaspurensis*, 92  
   *horni*, 6, 49, 50, 81  
   *kushwahi*, 18, 92  
   *microdentatus*, 15, 30, 65, 92, 94  
   *obesus*, 8, 9, 13, 18, 40, 42, 47, 48, 49,  
     50, 63, 64, 65, 71, 80, 81, 84, 92, 94  
   *parvidens*, 92, 93  
   *redemanni*, 92, 93, 94  
   *wallonensis*, 92, 93  
   sp., 6, 65  
   spp., 94  
*Operculitermes*, 117, 567, 568, 569
- P**
- Paraneotermes, 170  
   *simplicicornis*, 171  
 Parastylotermes, 117, 565, 566, 567, 570  
 Paratermes, 521, 522  
 Parotermes, 124  
 Parrhinotermes, 519, 520, 521, 527-529  
   *khassii khassii*, 529-532  
   *khassii ruiliensis*, 532  
 Pericapritermes  
   *dunensis*, 63  
   *latignathus durga*, 56, 67, 69

- Planocryptotermes*, 367, 368  
*nocens*, 368, 384, 385  
 Porotermes, 14, 106, 116, 134, 135, 137  
 sp., 14  
**POROTERMITINAE**, 38, 109, 110, 114, 115, 119, 120, 121, 123, 135, 136, 137, 138  
 Postelectrotermes, 91, 93, 116, 169, 170, 171, 172-176  
 bhimi, 175, 176-179  
 militaris, 14, 69, 71, 174, 175, 176, 179-184  
 nayari, 14, 174, 175, 176, 184-186  
 pasniensis, 175, 176, 186-189  
 pishinensis, 174, 175, 176, 190-191  
 Procapritermes, 119  
*Procoptotermes*, 521, 522  
 Procornitermes  
 triacifer, 62  
 Procryptotermes, 170, 172, 350, 353-356, 360, 369  
 dhari, 355, 356-360  
 fryeri, 354  
 hubbardi, 46  
 hunsurensis, 356, 360-364  
 valeriae, 356, 364-367  
 Proelectrotermes, 170  
 Prokalotermes, 170  
 Proneotermes, 170  
 Prorhinotermes, 12, 113, 117, 402, 404, 419, 518, 519, 520, 521-523  
 flavus, 524-527  
 inopinatus, 522  
 shiva, 524, 527  
**PRORHINOTERMITINAE**, 12, 113, 404, 520  
 Protermes, 119  
**PROTERMITIDAE**, 107, 110, 134, 166, 168  
 Protohamitermes, 16  
 sp., 15  
**PROTOZOA\***, 106  
*Psalidotermes*, 471, 472  
 Psammotermes, 84, 91, 101, 102, 117, 401, 406, 407, 408-410  
 allocerus, 410  
 hybostoma, 409, 410  
 rajasthanicus, 18, 82, 101, 410-415  
 voeltzkowi, 410  
**PSAMMOTERMITINAE**, 38, 84, 109, 110, 114, 117, 120, 121, 402, 404, 405-408  
 Pseudacanthotermes, 75  
 Pseudocapritermes  
 tikadari, 62  
 Pseudomicrotermes, 110  
 Pterotermes, 138, 170  
 occidentis, 21
- R**
- Reticulitermes, 104, 117, 403, 404, 468, 469, 470, 474, 494-497  
 assamensis, 497, 498-501, 505  
 chinensis, 497, 498, 501-505  
 flavipes, 88  
 lucifugus, 88  
 saraswati, 496, 497, 506-508  
 tirapi, 497, 508-510  
 Rhinotermes, 106, 401, 402, 518, 519, 520, 522, 533, 540  
 intermedius, 533  
 marginalis, 105  
 nasutus, 69  
 taurus, 69  
**RHINOTERMITIDAE**, 10, 11, 15, 23, 25, 37, 38, 76, 77, 84, 91, 109, 110, 113, 114, 117, 120, 121, 122, 400-405, 567, 568  
**RHINOTERMITINAE**, 12, 38, 107, 109, 110, 113, 114, 117, 120, 121, 400, 402, 404, 405, 517-521  
**RHINOTERMITINI**, 400  
 Rhyncotermes,  
 perarmatus, 58  
 Rostrotermes, 112  
 Rugitermes, 170  
 Ruptitermes, 101, 102  
 silvestrii, 33
- S**
- Sarvaritermes*, 112, 117, 567, 568, 569  
 faveolus (*Stylotermes*), 588

- Schedorhinotermes**, 117, 402, 404, 519,  
 520, 521, 532-537  
   *brevialatus*, 544, 559  
   *eleanorae*, 535, 536, 537-540  
   *longirostris*, 535, 536, 537, 540-544  
   *magnificus*, 549  
   *mediobscurus*, 535, 536, 537, 544-549  
   *sarawakensis*, 535, 536, 549-554  
   *tiwarii*, 62, 535, 536, 537, 554-559  
   *translucens*, 535, 536, 537, 559-563  
**Serritermes**, 401  
   *serrifer*, 15, 112, 118  
**SERRITERMITIDAE**, 15, 16, 23, 25, 38,  
 112, 114, 117-118, 120, 121, 122, 568  
**SERRITERMITINAE**, 107, 109, 110, 112,  
 400  
*Sinotermes*, 111, 118; 599, 600, 602  
   *hainanensis* (*Indotermes*), 602  
   *yunnanensis* (*Indotermes*), 603  
**Speculitermes**, 10, 17, 23, 91, 101, 102,  
 104, 119, 120  
   *cyclops*, 23  
   *cyclops rongrensis* (*Indotermes*), 602,  
   609, 616  
   *rongrensis* (*Indotermes*), 610  
   *sinhalensis*, 11  
**STAPHYLINIDAE\***, 94  
**Stolotermes**, 14, 106, 116, 134, 135, 137  
**STOLOTERMITINAE**, 38, 107, 109, 110,  
 114, 115, 120, 121, 123, 135, 136, 137,  
 138  
**Stylotermes**, 23, 93, 111, 116, 117, 565,  
 566, 567, 568-573  
   *ahmadi*, 570, 572, 573-575  
   *beesoni*, 570, 572, 575-577  
   *bengalensis*, 565, 570, 571, 572, 578-582  
   *chakratensis*, 570, 572, 582-584  
   *dunensis*, 570, 571, 573, 584-588  
   *faveolus*, 570, 571, 572, 588-591  
   *fletcheri*, 15, 20, 21, 566, 567, 570, 571,  
   572, 591-596  
   *parabengalensis*, 570, 572, 596-598  
**STYLOTERMITIDAE**, 15, 23, 25, 38,  
 111, 114, 116-117, 120, 121, 122, 404,  
 564-568, 570  
**STYLOTERMITINAE**, 109, 111, 404, 564  
**Subulitermes**, 119  
**Supella\***, 39  
   *longipalpa\**, 39  
**Synhamitermes**,  
   *quadriceps*, 18  
**Syntermes**, 27, 68, 119  
   *hageni*, 69  
   *spp.*, 68  
   *wheeleri*, 69  
**T**  
**Tauritermes**, 170  
**Tenuirostritermes**, 42  
   *tenuirostris*, 42, 45  
**Termes**, 6, 91, 105, 106, 119, 472, 513,  
 522, 528  
   *aequalis* (*Parrhinotermes*), 21, 528  
   *baculi*, 21  
   *castaneus* (*Neotermes*), 192  
   *fatalis*, 105  
   *fatidicum*, 105  
   *flavicolle* (*Kalotermes*), 274  
   *flavipes* (*Reticulitermes*), 495  
   *longirostris* (*Schedorhinotermes*), 540  
   *planus* (*Termitogeton*), 513  
   *pulsatorium*, 105  
   *umbilicatus* (*Termitogeton*), 513  
   *raffrayi* (*Coptotermes*), 434, 435  
   *sp.*, 540  
   *translucens* (*Schedorhinotermes*), 559  
**TERMITIDAE**, 10, 11, 15, 16, 23, 25, 36,  
 38, 76, 77, 91, 109, 110, 114, 118-119,  
 120, 121, 122, 134, 167, 400, 599, 601  
**TERMITINA**, 106  
**TERMITINAE**, 25, 38, 107, 109, 112, 114,  
 118, 120, 121, 400, 601  
**Termitogeton**, 117, 511, 512, 513-514  
   *minor*, 514  
   *planus*, 514  
   *umbilicatus*, 514-517  
*Termitogetonella*, 521, 522  
**TERMITOGETONINAE**, 38, 107, 109,  
 110, 114, 117, 120, 121, 402, 404, 405,  
 511-512, 513  
**TERMOPSIDAE**, 10, 12, 14, 23, 24, 25,

- 28, 29, 38, 76, 77, 110, 113, 115, 117,  
119, 121, 122, 123-125, 136
- TERMOPSINAE, 109, 110, 123, 135, 136
- TERMOPSINI, 135
- Termopsis*, 6, 106, 123, 124  
*radcliffei*, 126
- THYSANURA\*, 94
- Trinervitermes, 91, 92, 119  
*biformis*, 18, 81  
*heimi*, 18, 81
- Tsaitermes, 470  
*hunanensis*, 470  
*oocephalus*, 470
- Tuberculitermes, 119
- Tumulitermes  
*sp.*, 21
- U
- Ulmeriella* †, 135, 140
- URALOTERMITIDAE, 109
- X
- Xestotermopsis*, 124
- Z
- Zootermopsis*, 10, 42, 115, 124, 125  
*angusticollis*, 21, 40
- ZORAPTERA\*, 37
- Zorotypus*\*, 37  
*hubbardi*\*, 37

### ERRATA

<i>Page</i>	<i>Line</i>	<i>Printed as</i>	<i>Read</i>
63	9 from below	<i>pintai</i>	<i>pintoi</i>
107	4 from below	Subfam. Serritermitinae (1 genus)	Delete
126	12 from above	Figs. 72—77	Pl. 6 and Figs. 72—77
320	3 from below	Sen-Sarma and Thakur	Thakur
	2 from below	11-52	11, 52
469	last line	p. 480	p. 474
578	3 from above	Roonwal and Chhotani	Mathur and Chhotani
619	10, 14 and 18 from above	BOSE, G.	BOSE, GEETA

Dr. M. L. Roonwal, Ph.D., Sc.D. (Cantab.), F.N.A., has been engaged in termite research for over 35 years. He has successively been the Chief Research Officer (Forest Entomologist), Forest Research Institute, Dehradun ; the Director, Zoological Survey of India, Calcutta ; and the Professor of Zoology and Vice-Chancellor of the Jodhpur University, Jodhpur.

Dr. O. B. Chhotani, Ph.D., has been engaged in termite research for about 30 years at the Forest Research Institute, Dehradun ; and the Zoological Survey of India, Calcutta. He is currently Scientist SF (Joint Director) at the latter institution.